



US00D826816S

(12) **United States Design Patent**
Lokers et al.

(10) **Patent No.:** **US D826,816 S**
(45) **Date of Patent:** **** Aug. 28, 2018**

- (54) **TRUCK CAB**
- (71) Applicant: **Volvo Lastvagnar AB**, Göteborg (SE)
- (72) Inventors: **Vincent Lokers**, Greensboro, NC (US);
Lukas Yates, Greensboro, NC (US);
Sid Chiang, Greensboro, NC (US);
Herve Bertrand, Lyons (FR)
- (73) Assignee: **Volvo Lastvagnar AB**, Gothenburg (SE)
- (**) Term: **15 Years**
- (21) Appl. No.: **29/593,299**
- (22) Filed: **Feb. 8, 2017**
- (51) **LOC (11) Cl.** **12-08**
- (52) **U.S. Cl.**
USPC **D12/196**
- (58) **Field of Classification Search**
USPC D12/166, 167, 169, 171, 172, 190, 216
CPC B62D 25/10; B62D 25/16; B62D 25/168;
B60R 1/06
See application file for complete search history.

(56) **References Cited**

U.S. PATENT DOCUMENTS

- D313,966 S * 1/1991 Marlowe D12/181
- 5,499,690 A * 3/1996 Shearn B60K 11/04
180/68.4
- 5,576,899 A * 11/1996 Englander B60R 1/06
248/475.1
- 5,826,672 A * 10/1998 Holter B62D 25/10
180/69.21
- 5,947,520 A * 9/1999 McHorse B62D 35/001
280/154
- D424,495 S * 5/2000 Damon D12/196
- D431,806 S * 10/2000 Damon D12/196
- 6,230,832 B1 * 5/2001 von Mayenburg B60K 11/08
180/68.1

- 6,454,035 B1 * 9/2002 Waskow B62D 33/067
180/69.21
- 6,644,720 B2 * 11/2003 Long B62D 25/168
296/180.4
- D491,851 S * 6/2004 Perfetti D12/181
- D535,597 S * 1/2007 Herpel D12/181
- 7,195,307 B2 * 3/2007 Tucker B62D 25/10
16/225
- 8,226,158 B1 * 7/2012 Jackson B62D 25/168
280/160
- 8,528,936 B2 * 9/2013 Johnson B62D 25/18
180/271
- D707,608 S * 6/2014 Smith D12/181
- 8,800,703 B2 * 8/2014 Miller B62D 25/10
180/69.2
- D760,633 S * 7/2016 Peltola D12/181
- D772,127 S * 11/2016 Heilaneh D12/181
- D773,360 S * 12/2016 Heilaneh D12/181
- D782,381 S * 3/2017 Conway D12/196
- D782,947 S * 4/2017 Sausaman D12/181

(Continued)

OTHER PUBLICATIONS

Images of Mack CXU Pinnacle Truck, released 2006, 2 pages.

Primary Examiner — Susan Bennett Hattan

Assistant Examiner — Suzanne E Tisdell

(74) *Attorney, Agent, or Firm* — Tucker Ellis LLP

(57) **CLAIM**

The ornamental design for a truck cab, as shown and described.

DESCRIPTION

FIG. 1 is a perspective view of a truck cab showing our new design.

FIG. 2 is a front view thereof.

FIG. 3 is a rear view thereof.

FIG. 4 is a right side view thereof.

FIG. 5 is a left side view thereof; and,

FIG. 6 is a top view thereof.

1 Claim, 6 Drawing Sheets

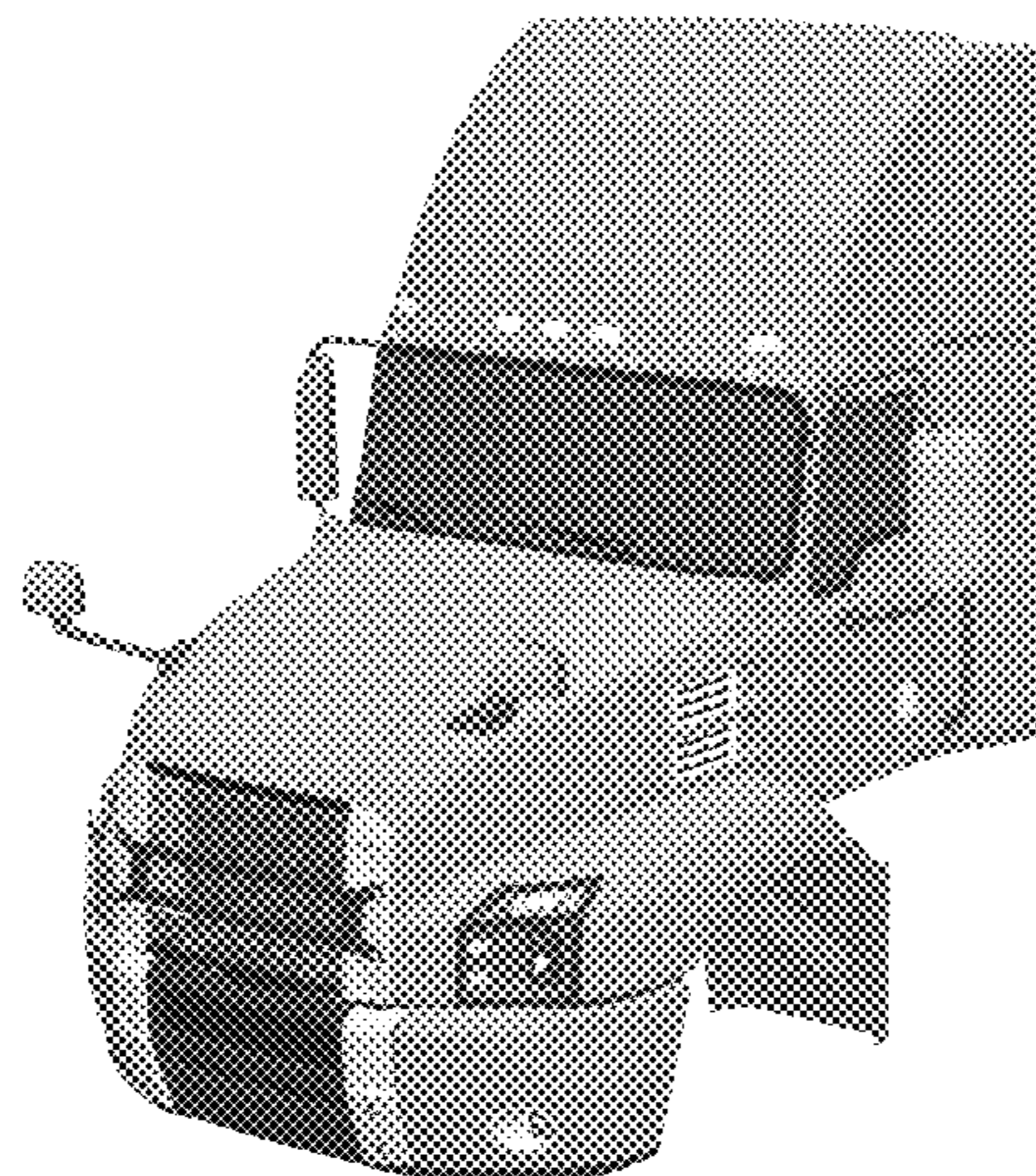

(56)

References Cited

U.S. PATENT DOCUMENTS

9,643,658	B2 *	5/2017	Jaynes	B62D 25/168
D788,667	S *	6/2017	Dempsey	D12/183
D805,981	S *	12/2017	Conway	D12/196
D809,985	S *	2/2018	Milton	D12/196
D812,535	S *	3/2018	Milton	D12/181
D813,772	S *	3/2018	Anderson	D12/196
D814,376	S *	4/2018	Anderson	D12/196
D816,004	S *	4/2018	Milton	D12/196
2003/0072094	A1 *	4/2003	Englander	B60R 1/0605 359/871
2003/0146648	A1 *	8/2003	Lustig	B62D 25/10 296/190.11
2005/0028722	A1 *	2/2005	Arntz	G09F 17/00 116/173

* cited by examiner

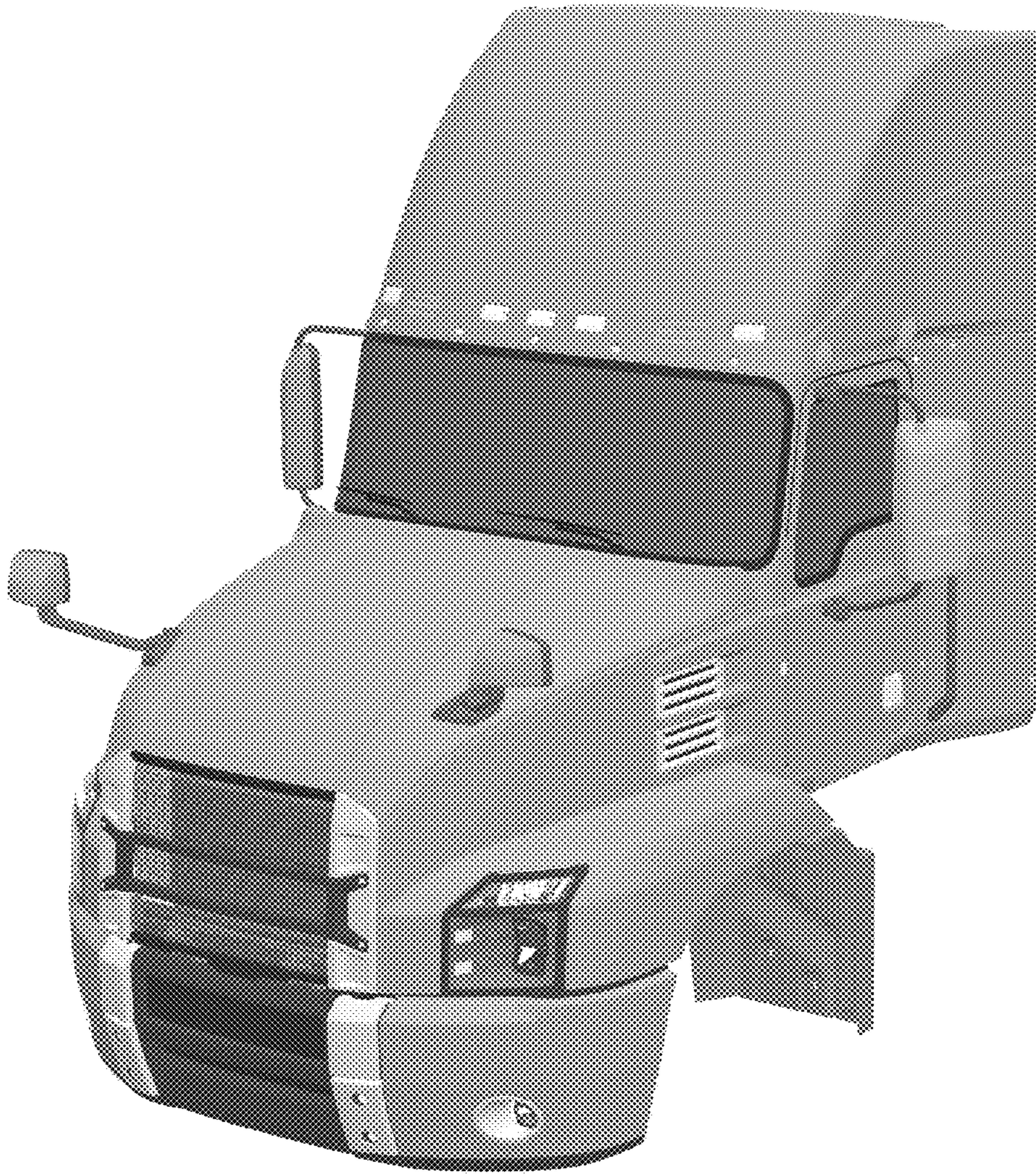

FIG. 1

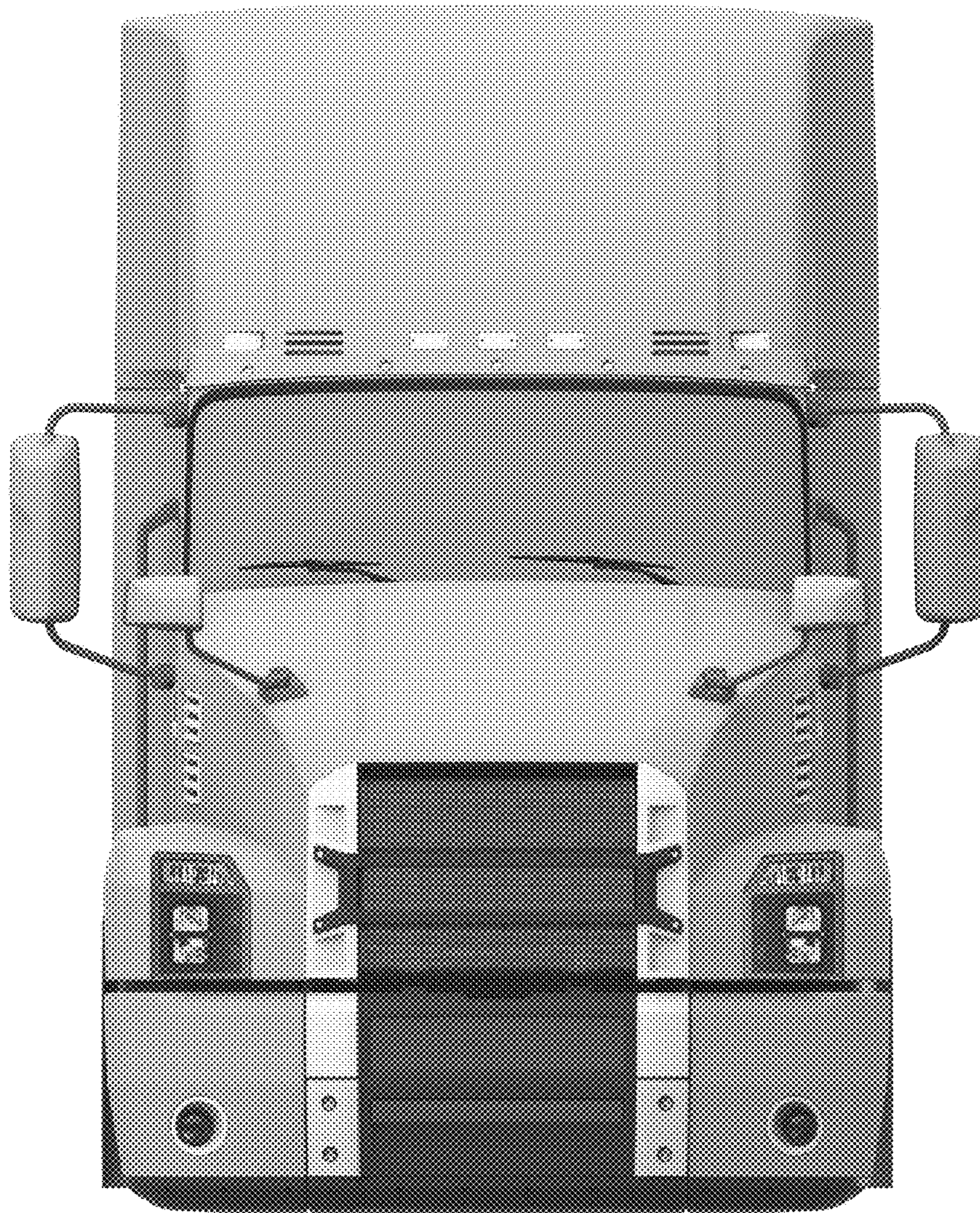

FIG. 2

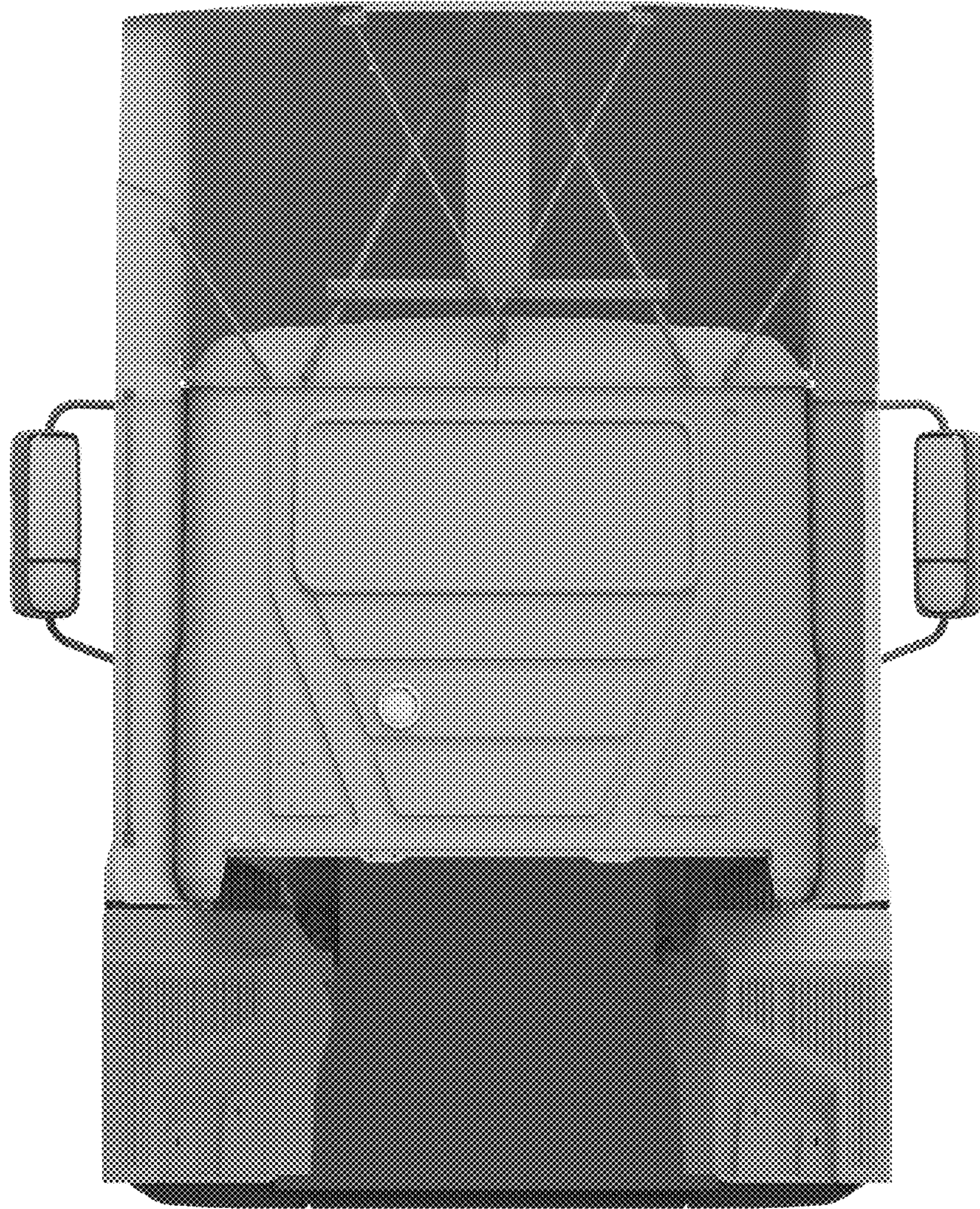

FIG. 3



FIG. 4



FIG. 5

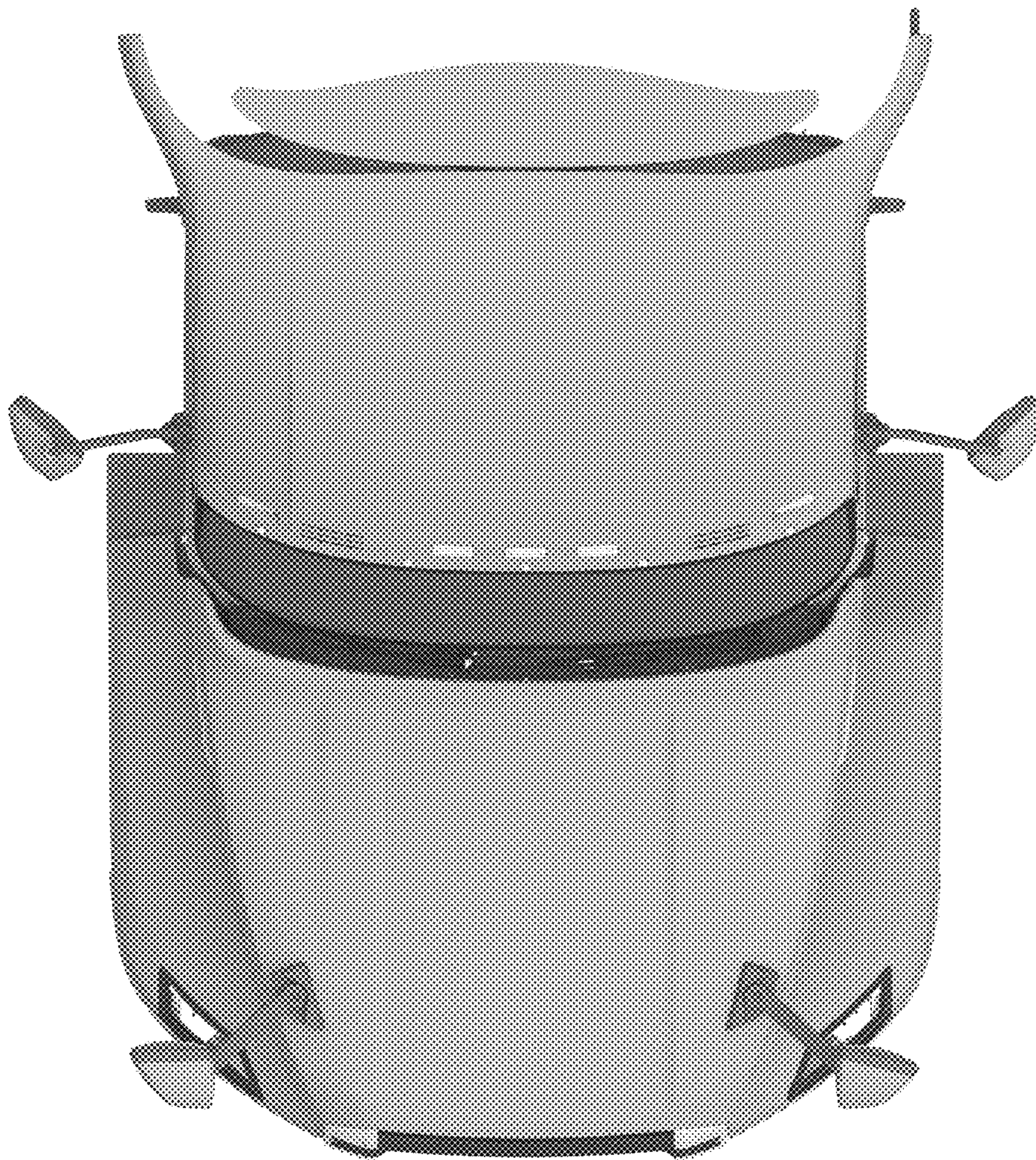

FIG. 6