



US00D826777S

(12) **United States Design Patent**
Ying et al.

(10) **Patent No.:** **US D826,777 S**

(45) **Date of Patent:** **** Aug. 28, 2018**

(54) **SELF-BALANCED VEHICLE**

(71) Applicant: **HANGZHOU CHIC INTELLIGENT TECHNOLOGY CO., LTD.**,
Hangzhou (CN)

(72) Inventors: **Jiawei Ying**, Hangzhou (CN); **Keping Xiao**, Hangzhou (CN)

(73) Assignee: **HANGZHOU CHIC INTELLIGENT TECHNOLOGY CO., LTD.**,
Hangzhou (CN)

(**) Term: **15 Years**

(21) Appl. No.: **29/589,809**

(22) Filed: **Jan. 4, 2017**

(30) **Foreign Application Priority Data**

Dec. 26, 2016 (CN) 2016 3 0646136

(51) **LOC (11) Cl.** **12-14**

(52) **U.S. Cl.**
USPC **D12/1; D21/760**

(58) **Field of Classification Search**

USPC D12/1; D21/419, 763, 421, 423, 426,
D21/760, 765, 766, 769, 771, 776, 803
CPC A63C 17/01; A63C 17/12; A63C 2203/00;
A63C 2203/01; A63C 2203/012; A63C
2203/013; A63C 2203/40; A63C 2203/52;
A63C 17/0033; A63C 17/016; A63C
17/08; B62D 51/02; B62D 51/001; B62D
61/00; B62D 37/00; B62K 2202/00;
B62K 2207/00; B62K 2207/02; B62K
2207/04; B62K 3/007; B62K 17/00;
B62K 11/007; B60N 2/002; B60G 17/019

See application file for complete search history.

(56) **References Cited**

U.S. PATENT DOCUMENTS

5,236,208	A *	8/1993	Welsh	A63C 17/013 280/11.27
9,403,573	B1 *	8/2016	Mazzei	B62D 51/02
9,604,692	B1 *	3/2017	Kim	B62K 23/08
D783,452	S *	4/2017	Ying	D12/1
D784,197	S *	4/2017	Ying	D12/1
D786,994	S *	5/2017	Chen	D21/760
2005/0242538	A1 *	11/2005	Hiramatsu	A63C 17/004 280/92
2017/0088211	A1 *	3/2017	Jiang	B62K 11/007
2017/0166278	A1 *	6/2017	Lu	B62K 3/007
2017/0217529	A1 *	8/2017	Chen	B62K 11/007

* cited by examiner

Primary Examiner — T. Chase Nelson

Assistant Examiner — Ania Aman

(74) *Attorney, Agent, or Firm* — Hemisphere Law, PLLC;
Zhigang Ma

(57) **CLAIM**

The ornamental design for a self-balanced vehicle, as shown and described.

DESCRIPTION

FIG. 1 is a perspective view of an electric balance vehicle showing our new design;
FIG. 2 is a front view thereof;
FIG. 3 is a rear view thereof;
FIG. 4 is a left side view thereof;
FIG. 5 is a right side view thereof;
FIG. 6 is a top plan view thereof; and,
FIG. 7 is a bottom plan view thereof.

The broken lines showing of the remainder of the electric balance vehicle is for illustrative purposes only and form no part of the claimed design.

1 Claim, 7 Drawing Sheets

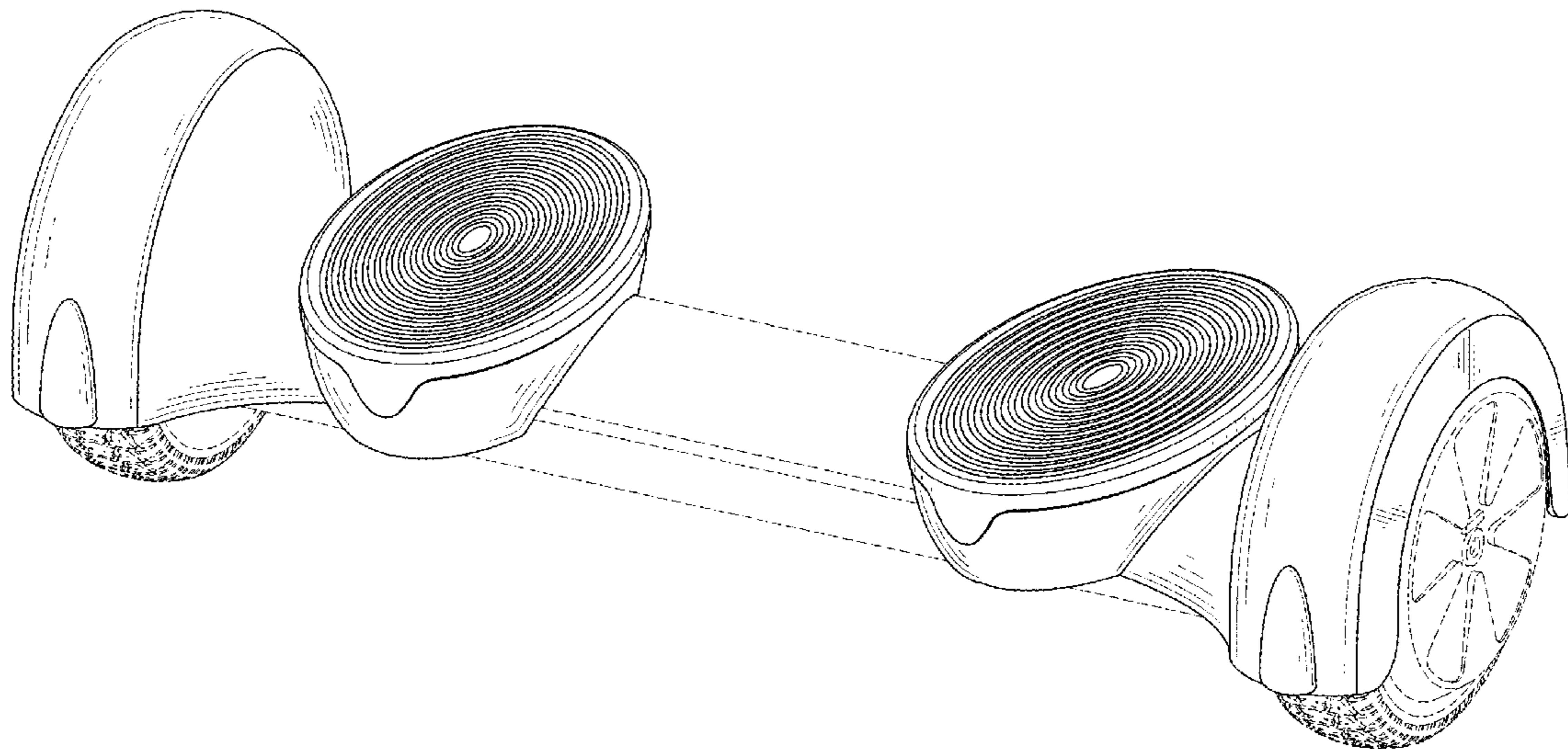

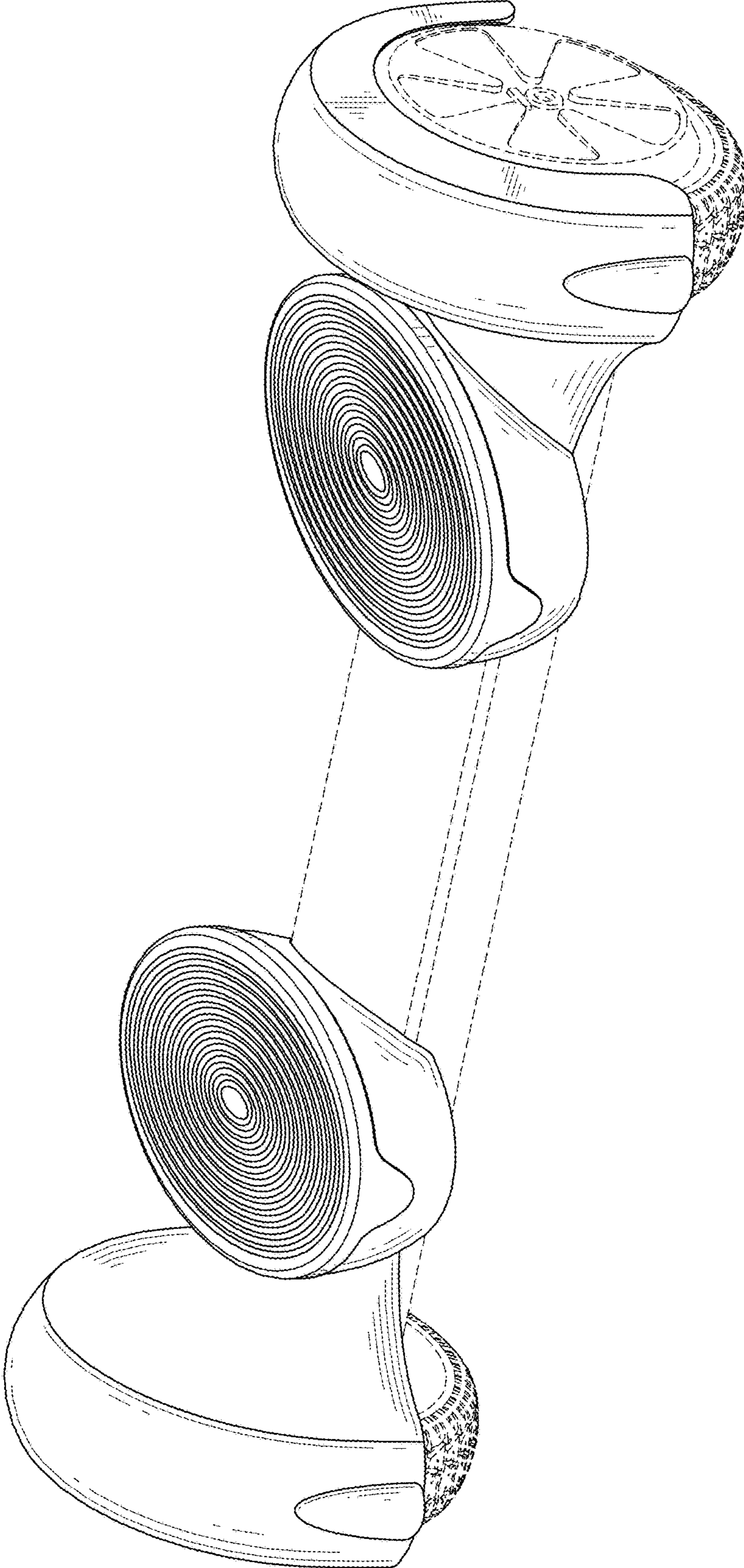

FIG. 1

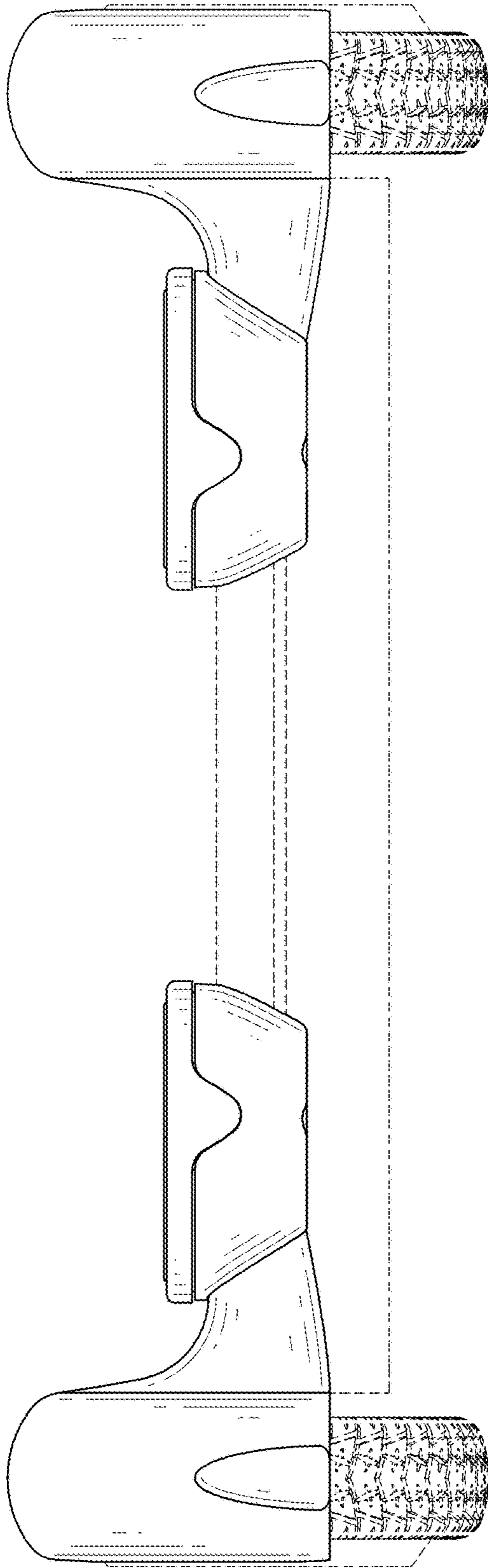

FIG. 2

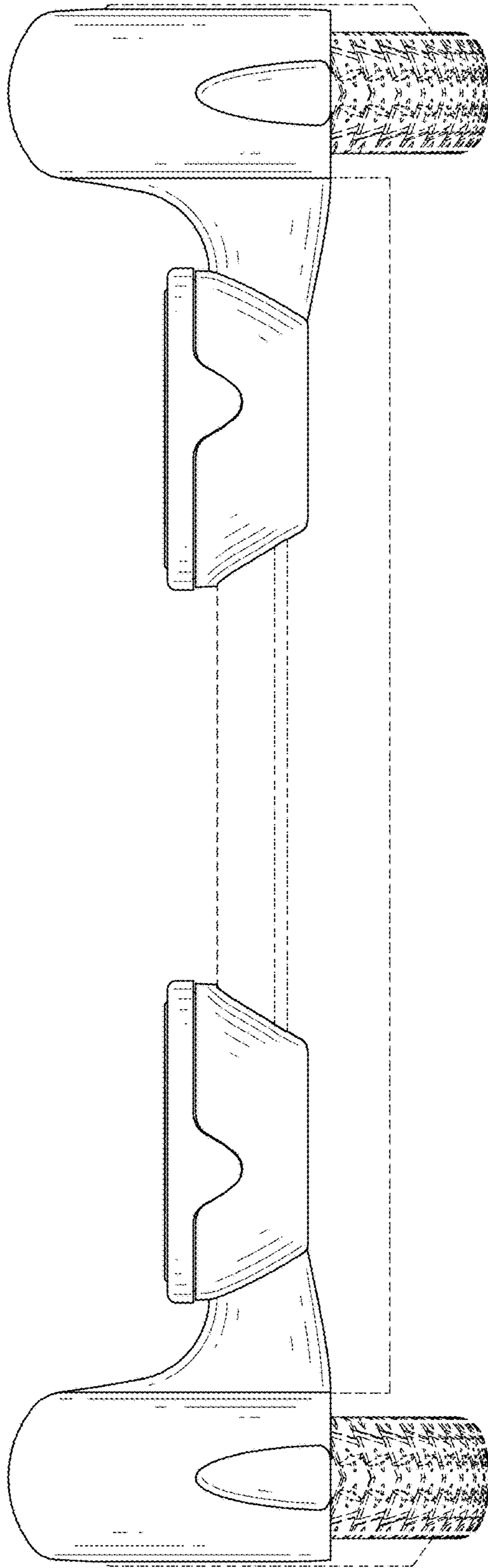

FIG. 3

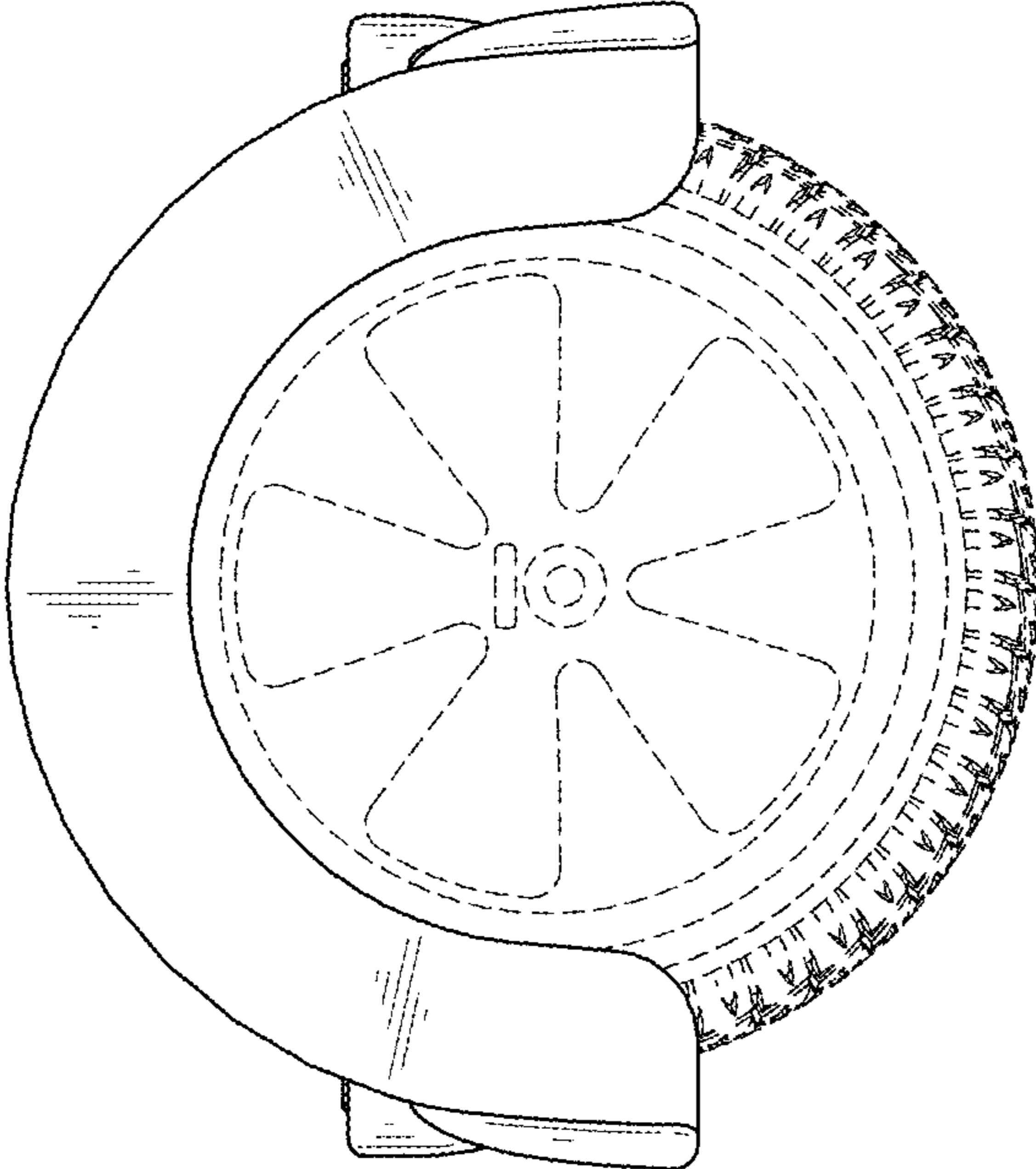

FIG. 4

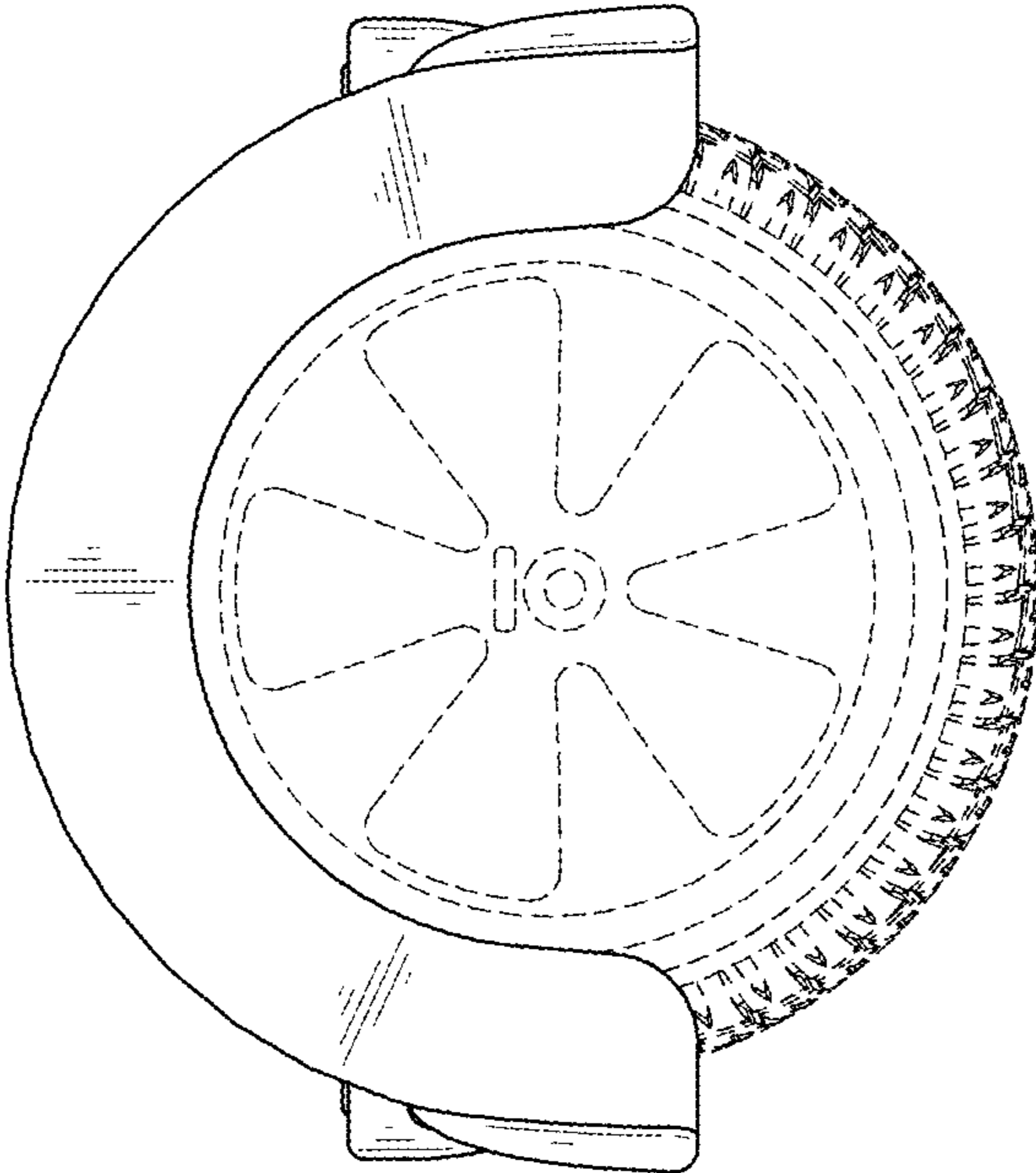

FIG. 5

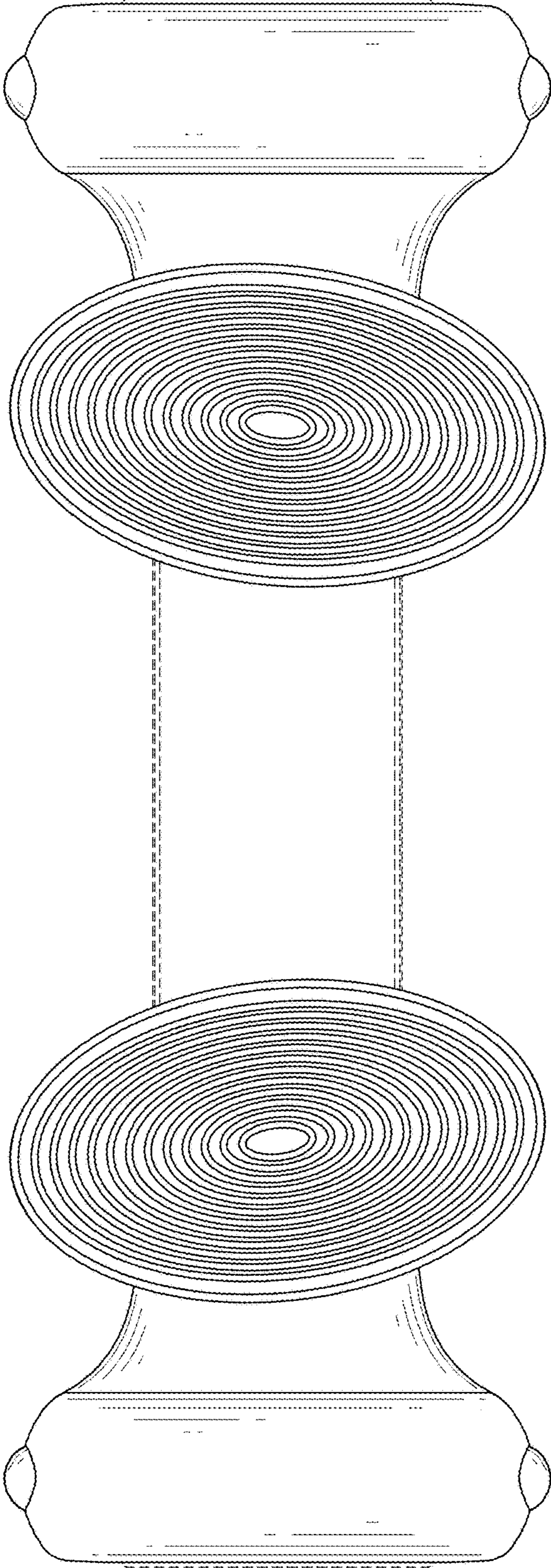

FIG. 6

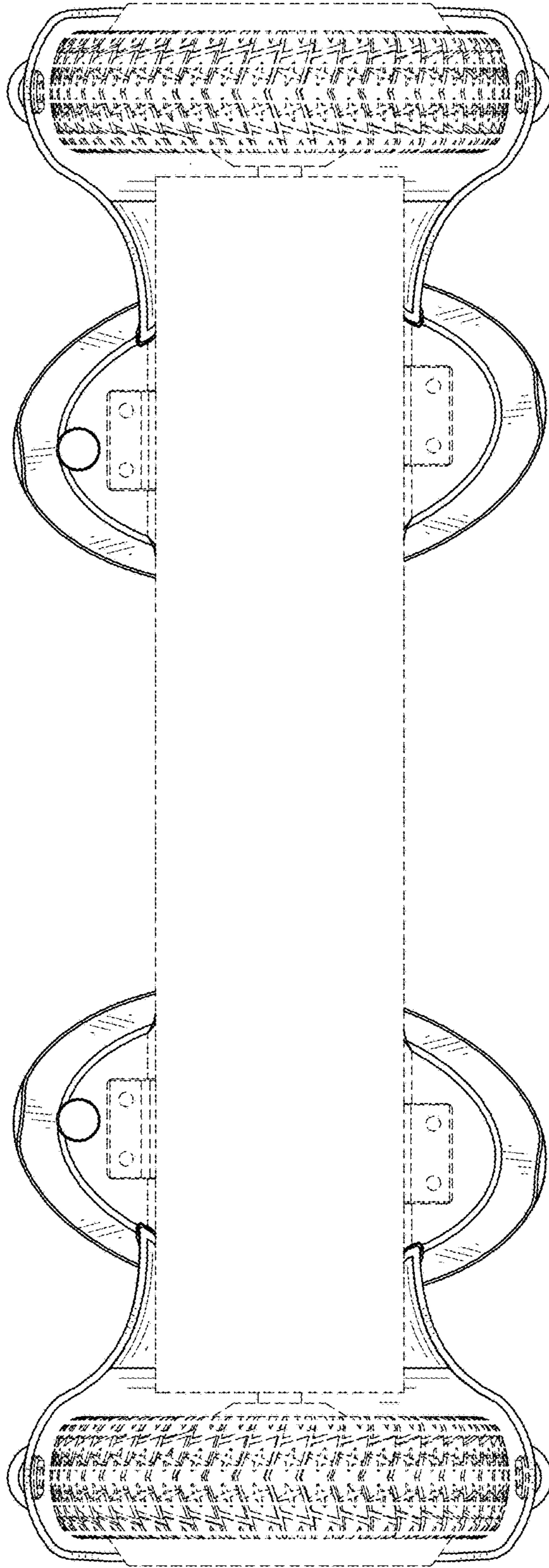

FIG. 7