



US00D826743S

(12) **United States Design Patent**
Hsu et al.

(10) **Patent No.:** **US D826,743 S**

(45) **Date of Patent:** **** Aug. 28, 2018**

(54) **INDUSTRIAL ROBOT CALIBRATION APPARATUS**

(71) Applicant: **DELTA ELECTRONICS, INC.**,
Taoyuan (TW)

(72) Inventors: **Chih-Ming Hsu**, Taoyuan (TW);
Jun-Huang Li, Taoyuan (TW);
Hsiu-Ling Cho, Taoyuan (TW)

(73) Assignee: **DELTA ELECTRONICS, INC.**,
Taoyuan (TW)

(**) Term: **15 Years**

(21) Appl. No.: **29/590,522**

(22) Filed: **Jan. 11, 2017**

(30) **Foreign Application Priority Data**

Nov. 24, 2016 (CN) 2016 3 0572269

(51) **LOC (11) Cl.** **10-04**

(52) **U.S. Cl.**
USPC **D10/65; D10/70**

(58) **Field of Classification Search**
USPC D10/65, 70; D15/199
CPC B25J 9/1692; G05B 19/18; G05B
2219/39001; G05B 2219/39024; G05B
2219/39019; G05B 2219/39041; G05B
2219/40621; G01B 21/042
See application file for complete search history.

(56) **References Cited**

U.S. PATENT DOCUMENTS

6,070,109 A * 5/2000 McGee B25J 9/1692
700/254
7,684,898 B2 * 3/2010 Pagel B25J 9/1692
700/166

8,406,922 B2 * 3/2013 Nemmers B25J 9/1692
700/182
2017/0151670 A1 * 6/2017 Huang B25J 9/1692

* cited by examiner

Primary Examiner — Antoine Duval Davis

(74) *Attorney, Agent, or Firm* — Kirton McConkie; Evan
R. Witt

(57) **CLAIM**

The ornamental design for an industrial robot calibration apparatus, as shown and described.

DESCRIPTION

FIG. 1 is a perspective view of an industrial robot calibration apparatus showing our new design; FIG. 2 is another perspective view thereof; FIG. 3 is a front elevational view thereof; FIG. 4 is a rear elevational view thereof; FIG. 5 is a left side elevational view thereof; FIG. 6 is a right side elevational view thereof; FIG. 7 is a top plan view thereof; FIG. 8 is a bottom plan view thereof; and, FIG. 9 is a perspective view showing the use status of the industrial robot calibration apparatus for calibrating the tool center point of an industrial robot. The broken line portions in the drawing views are included to show unclaimed subject matter only and form no part of the claimed design.

1 Claim, 9 Drawing Sheets

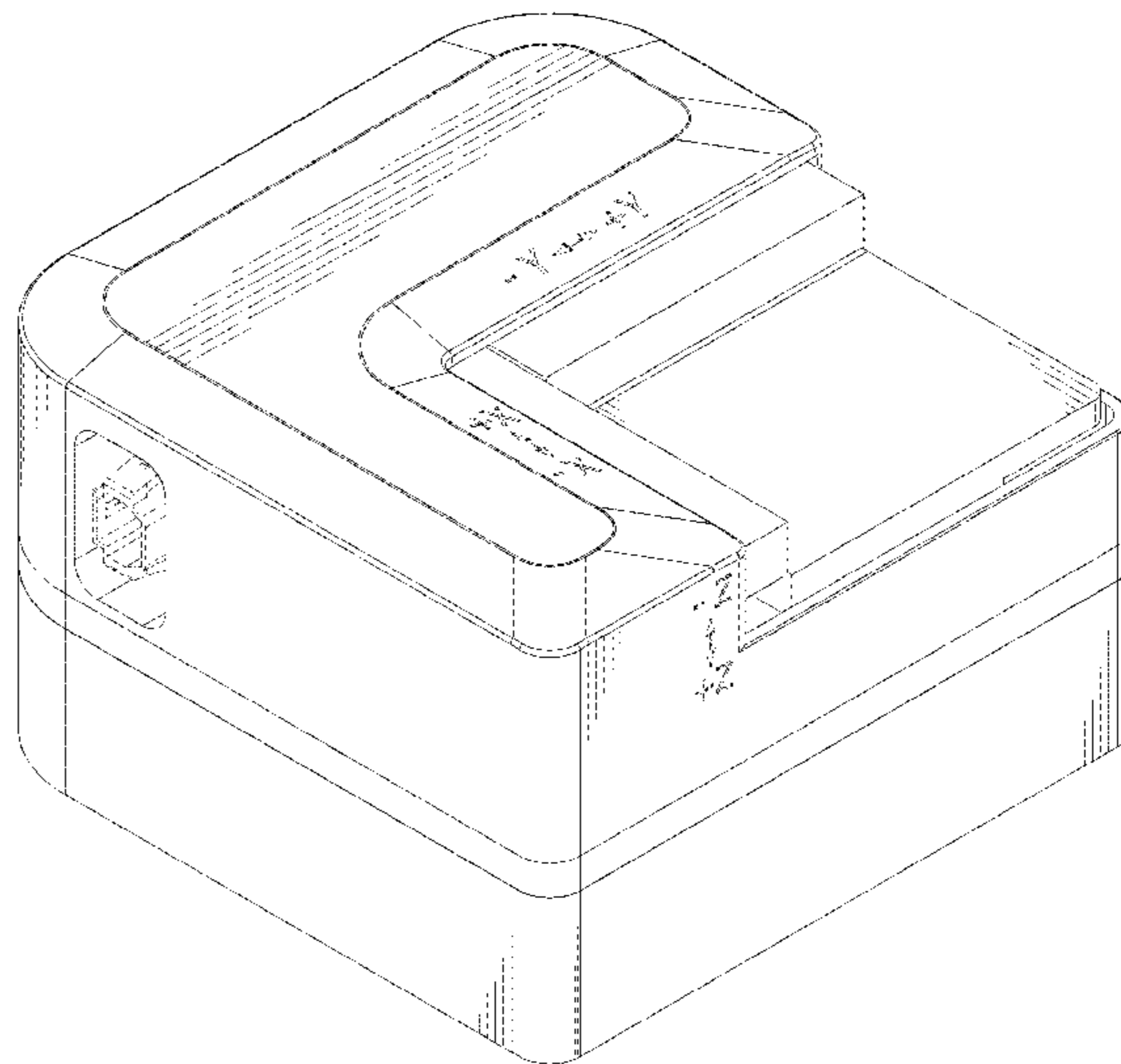
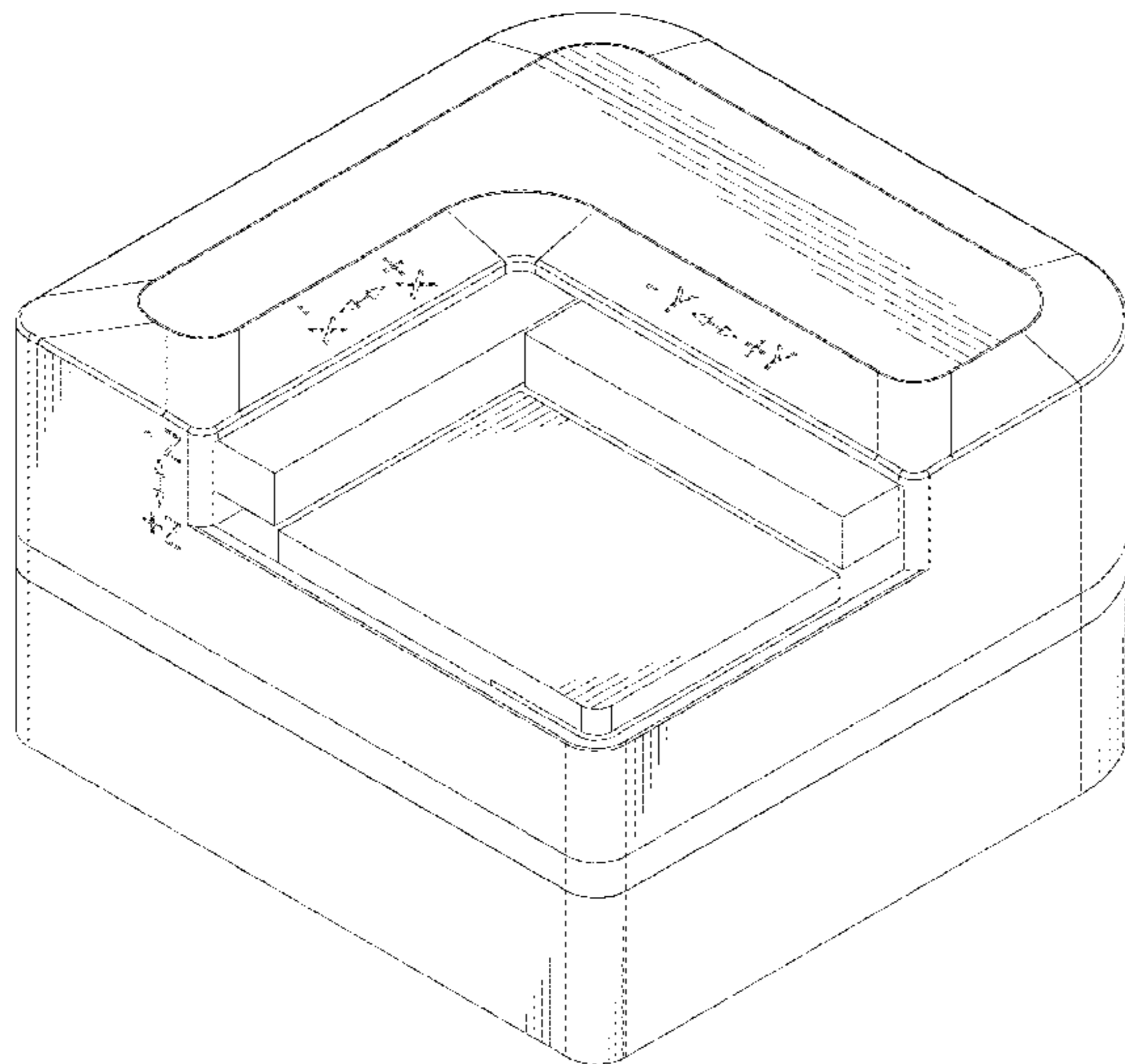

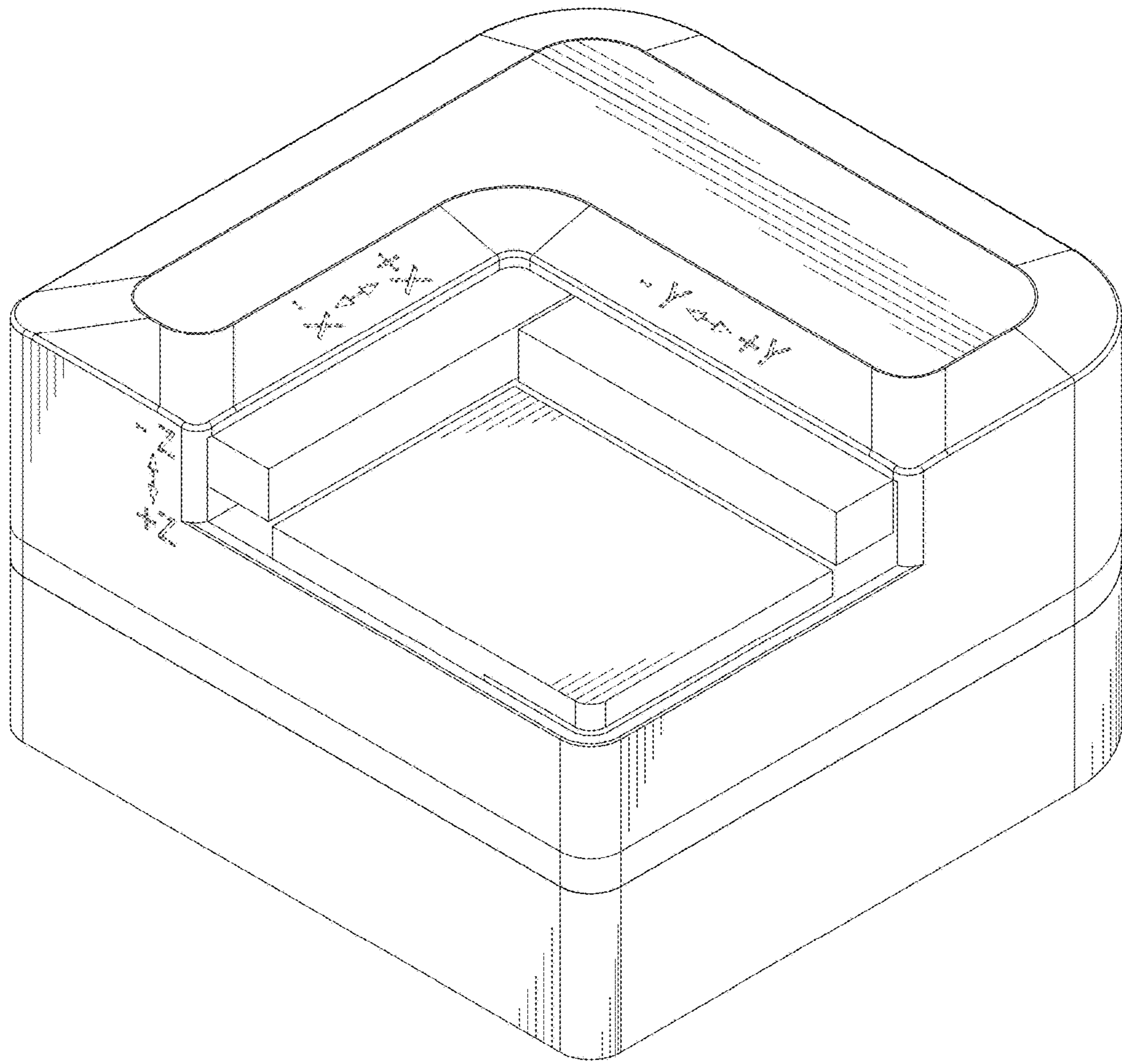

FIG. 1

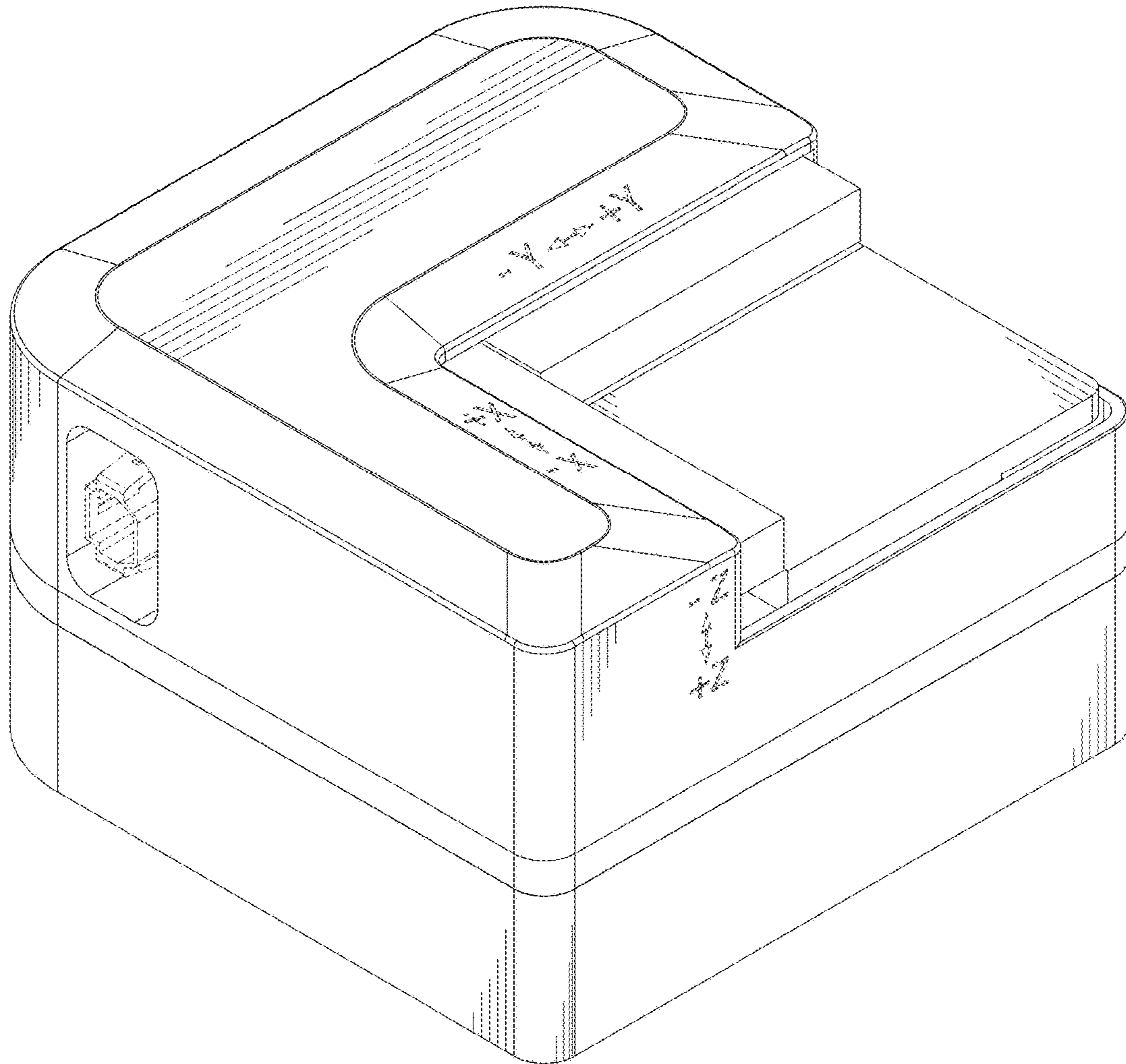

FIG. 2

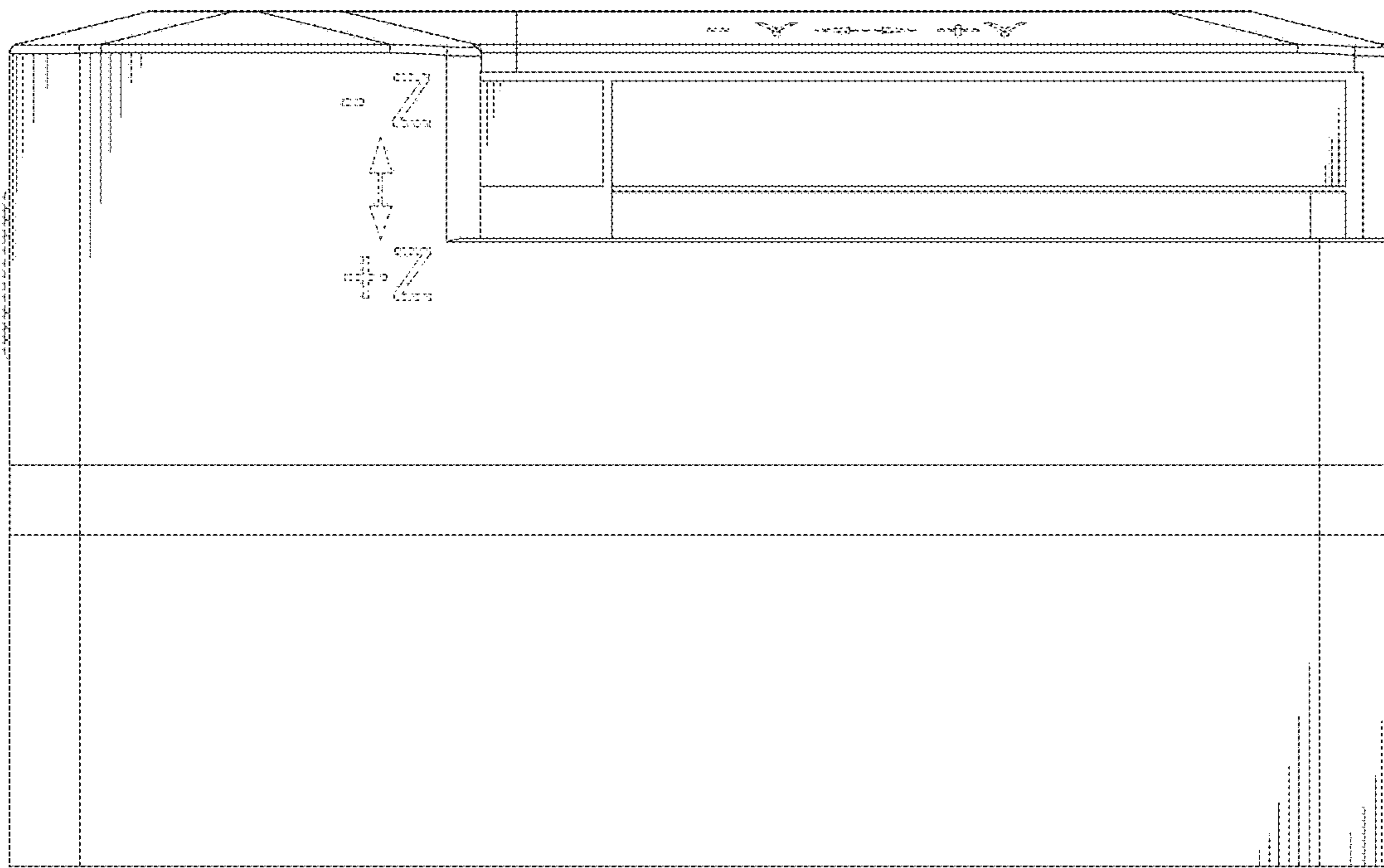

FIG. 3

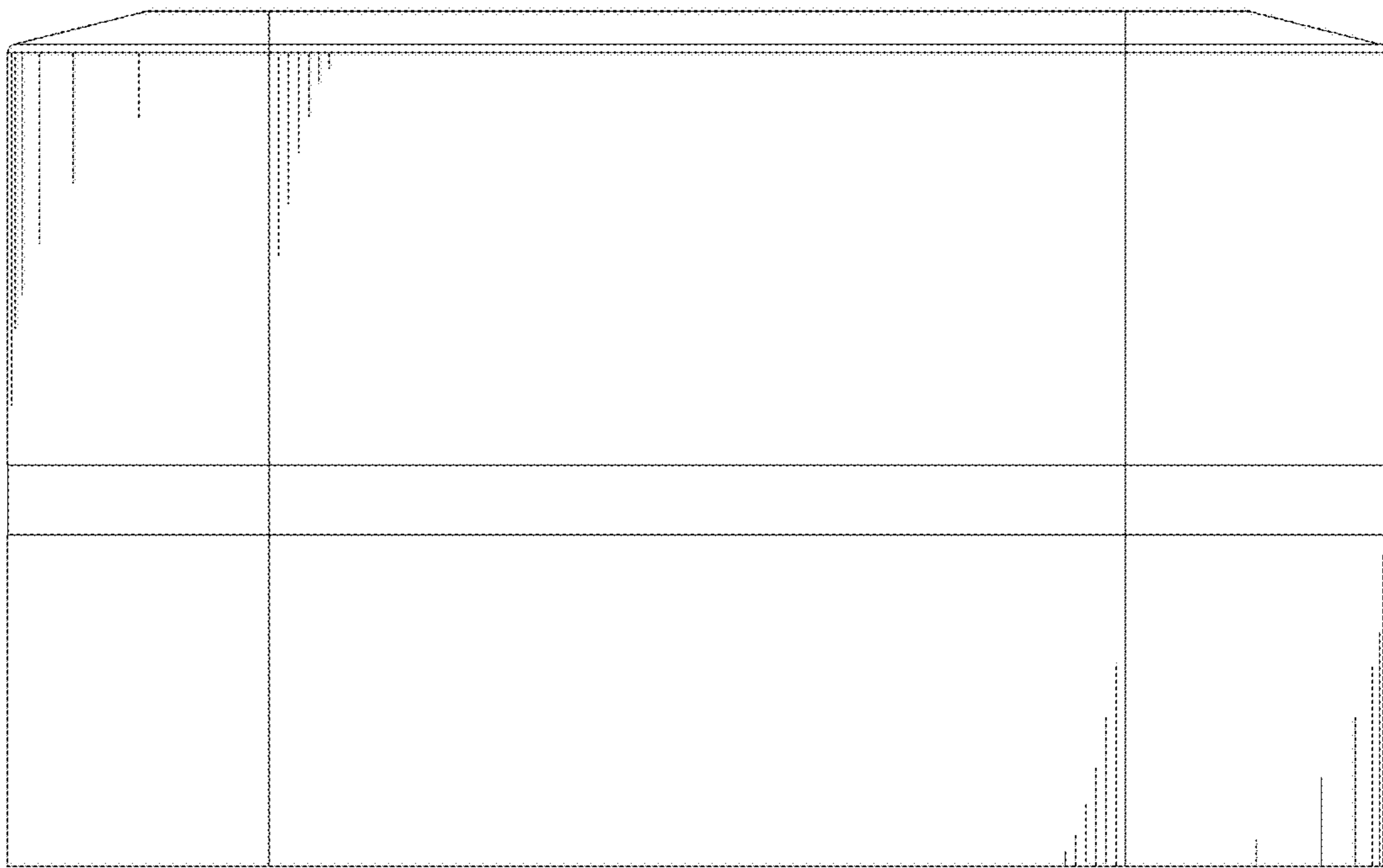

FIG. 4

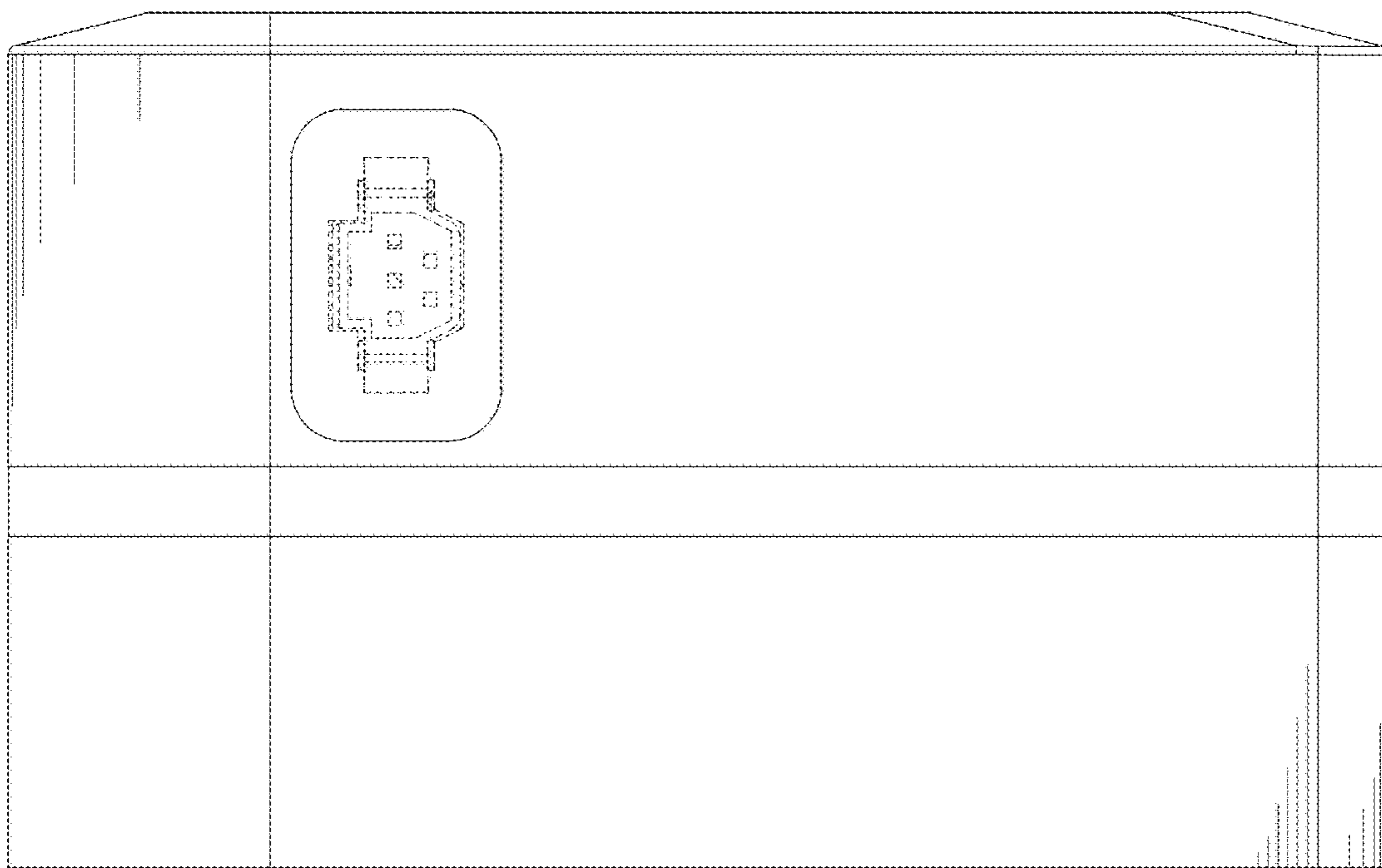

FIG. 5

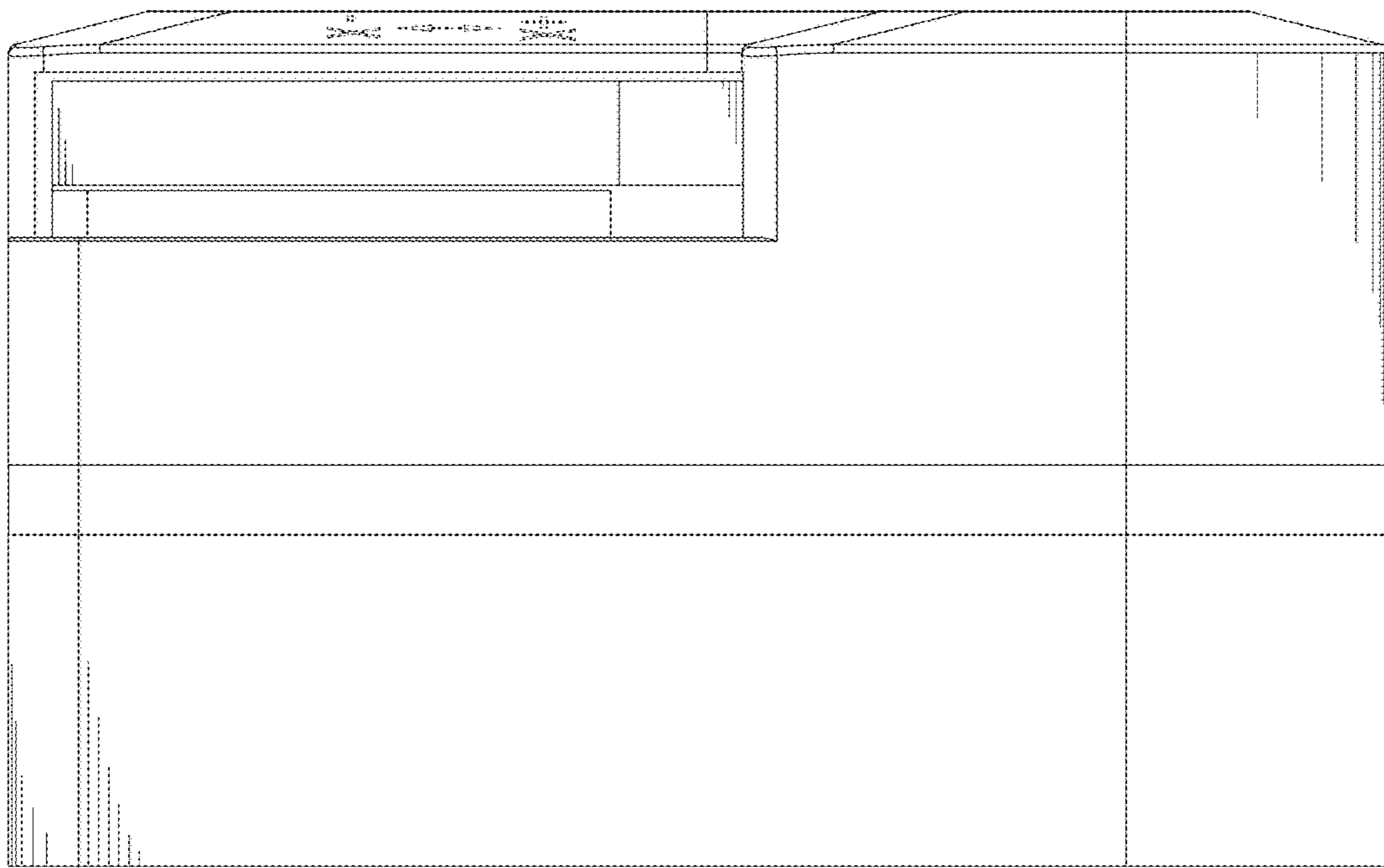

FIG. 6

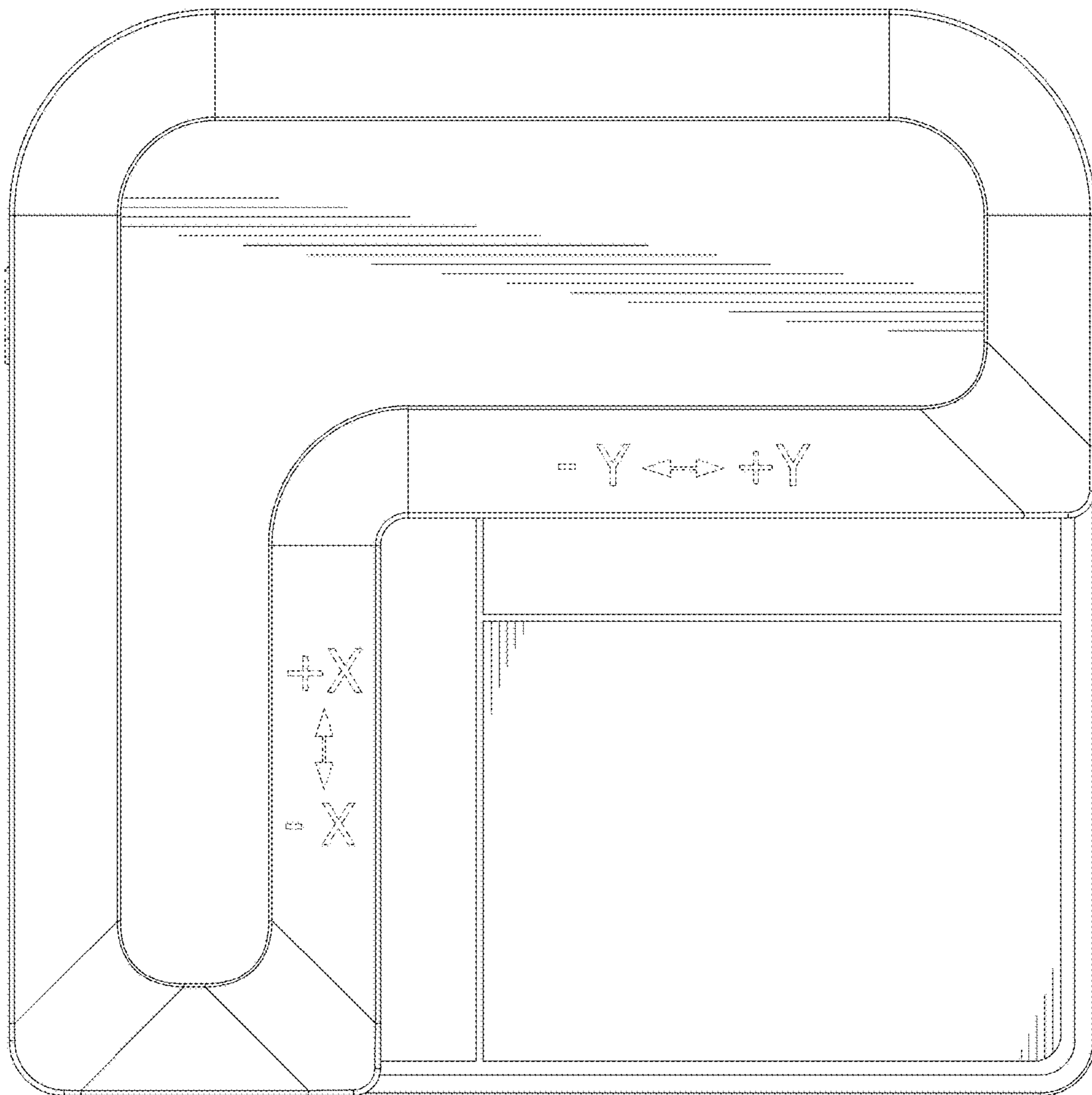

FIG. 7

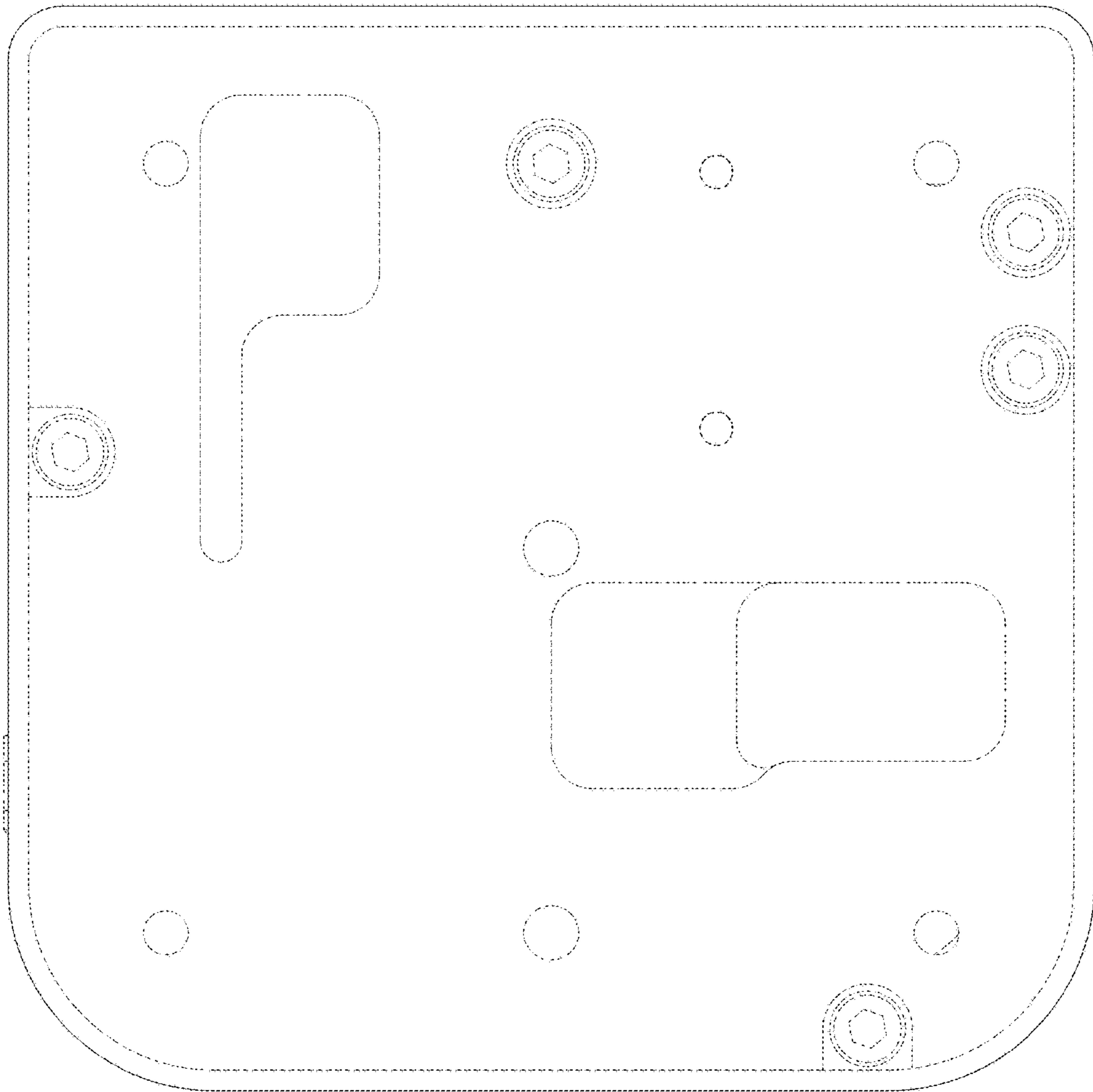

FIG. 8

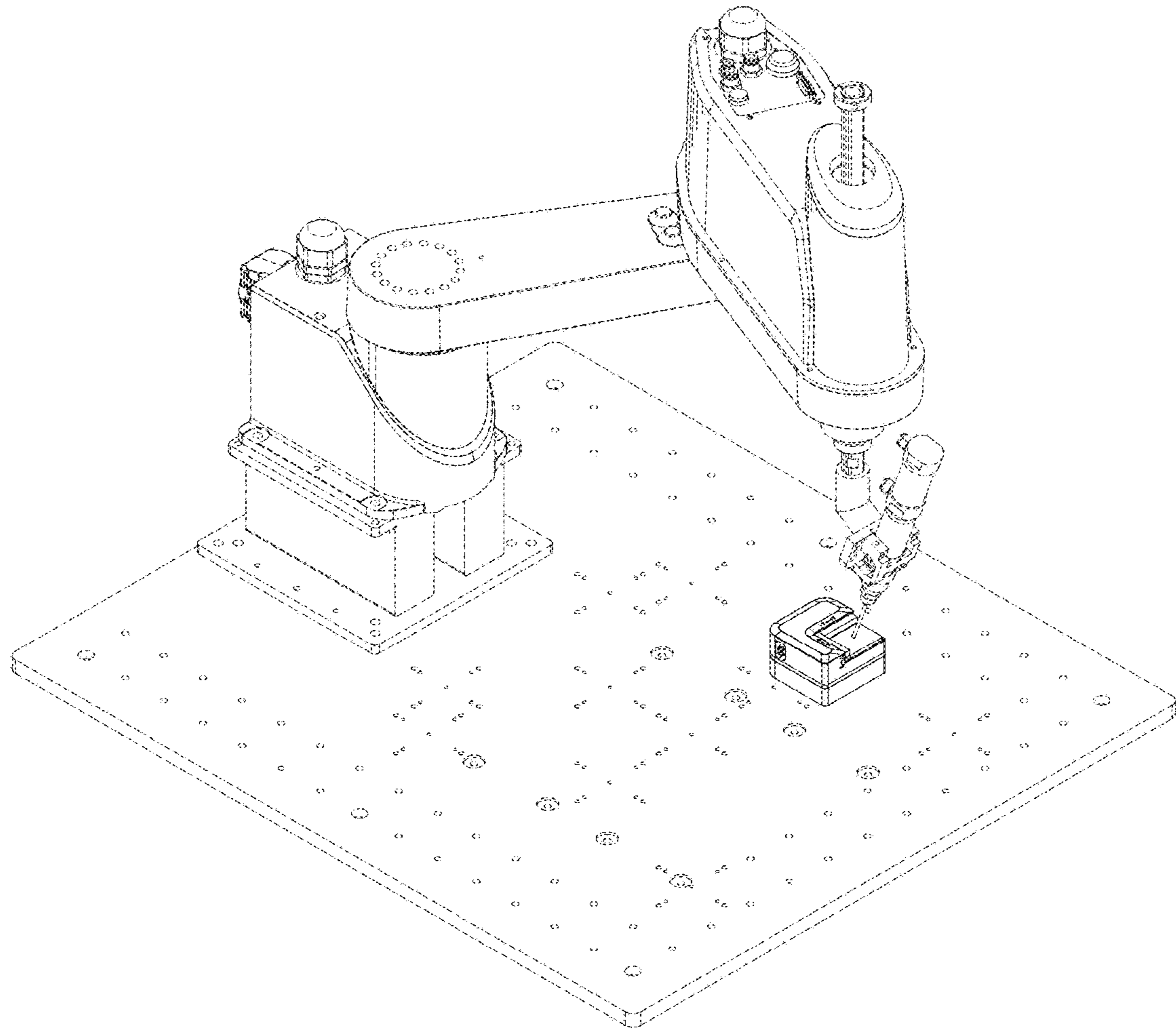

FIG. 9