



US00D826679S

(12) **United States Design Patent** (10) **Patent No.:** **US D826,679 S**
Anderson et al. (45) **Date of Patent:** **** Aug. 28, 2018**

(54) **TOOL TIP**
(71) Applicants: **Wayne Anderson**, Northport, NY (US);
Warren Anderson, Northport, NY (US)
(72) Inventors: **Wayne Anderson**, Northport, NY (US);
Warren Anderson, Northport, NY (US)
(**) Term: **15 Years**
(21) Appl. No.: **29/622,415**
(22) Filed: **Oct. 17, 2017**

3,891,017 A * 6/1975 Iskra B25B 15/007
81/436
D371,946 S * 7/1996 Giblin D8/82
6,176,161 B1 * 1/2001 Huang B25B 15/005
81/177.2
D453,289 S * 2/2002 Campbell D8/86
6,886,431 B1 * 5/2005 Petrsorich F16B 23/0015
81/436
D659,501 S * 5/2012 Wood D8/86
D669,330 S * 10/2012 Wood D8/82
D754,513 S * 4/2016 Burch D8/86
2010/0192736 A1 * 8/2010 Burch B25B 15/005
81/438

* cited by examiner

Related U.S. Application Data

(62) Division of application No. 29/560,473, filed on Apr. 7, 2016, now Pat. No. Des. 803,023.
(51) **LOC (11) Cl.** **08-04**
(52) **U.S. Cl.**
USPC **D8/86**
(58) **Field of Classification Search**
USPC D8/82, 85, 86, 14, 71
CPC B25B 15/00; B25B 15/02; B25B 15/001;
B25B 15/002; B25B 15/004; B25B
15/005; B25B 15/007; B25B 15/008;
B25B 23/10; B25B 23/0035; B25B
23/0042
See application file for complete search history.

Primary Examiner — Philip S Hyder

(74) *Attorney, Agent, or Firm* — Andrew F. Young, Esq.;
Lackebach Siegel, LLP

(57) **CLAIM**

The ornamental design for a tool tip, as shown and described.

DESCRIPTION

FIG. 1 is a front perspective view of a tool tip of the present invention.

FIG. 2 is a front elevation view thereof, the rear elevation view thereof being disclaimed and not shown for that reason. FIG. 3 is a right elevation view thereof, the left elevation view being a mirror image thereof; and,

FIG. 4 is a top plan view thereof, the bottom plan view being a mirror image thereof.

The surfaces are lined for contour only and no claim is made to any particular surface texture. The dash-dot-dash line mark claim boundary limits and the disclaimed lines of dash-dash indicate environmental matter to which no claim is made.

(56) **References Cited**

U.S. PATENT DOCUMENTS

2,431,628 A * 11/1947 Waarich F16B 23/0015
411/407
3,175,593 A * 3/1965 Launay B21K 1/463
411/403
3,695,321 A * 10/1972 Garehime, Jr. B25B 15/007
411/403

1 Claim, 2 Drawing Sheets

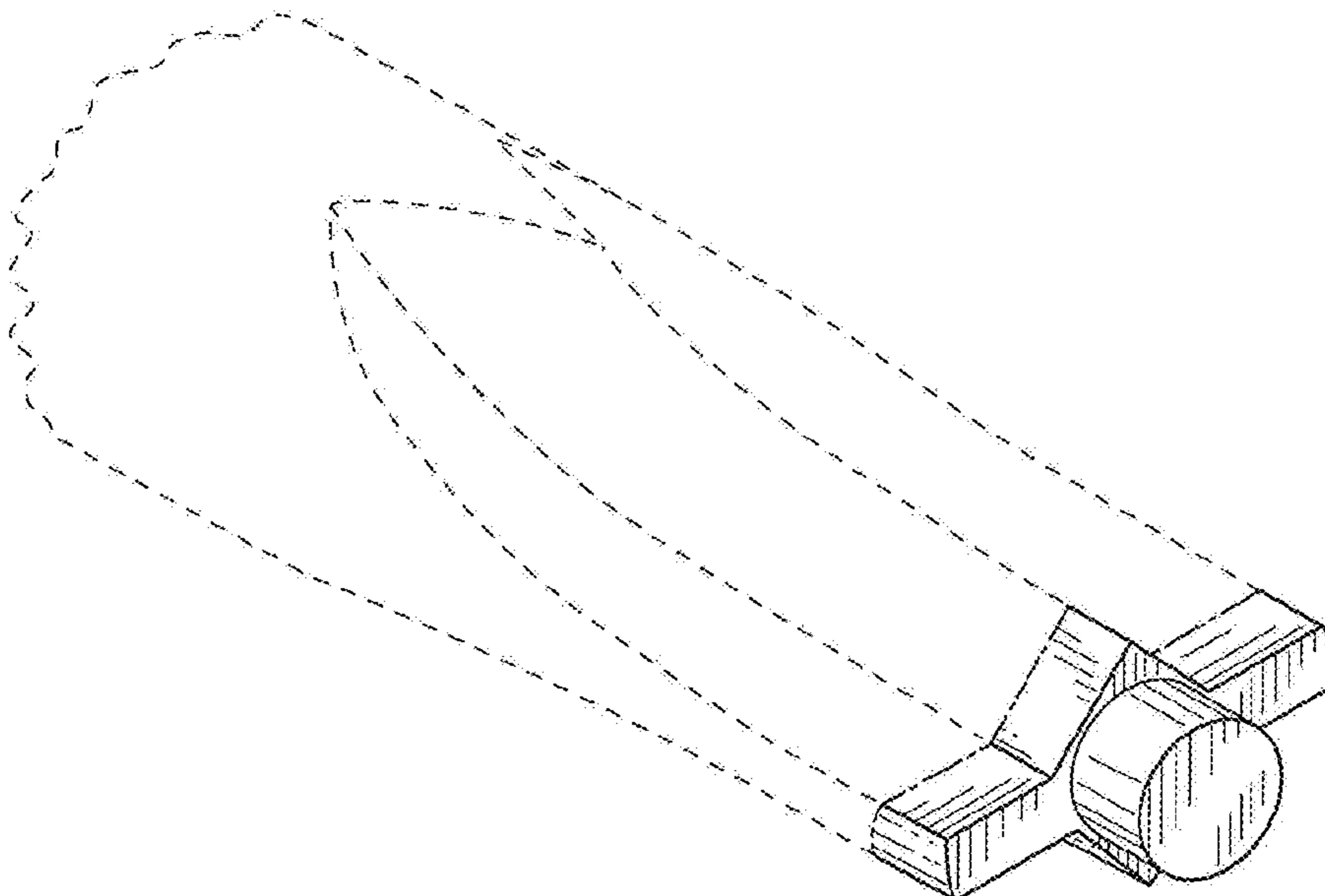

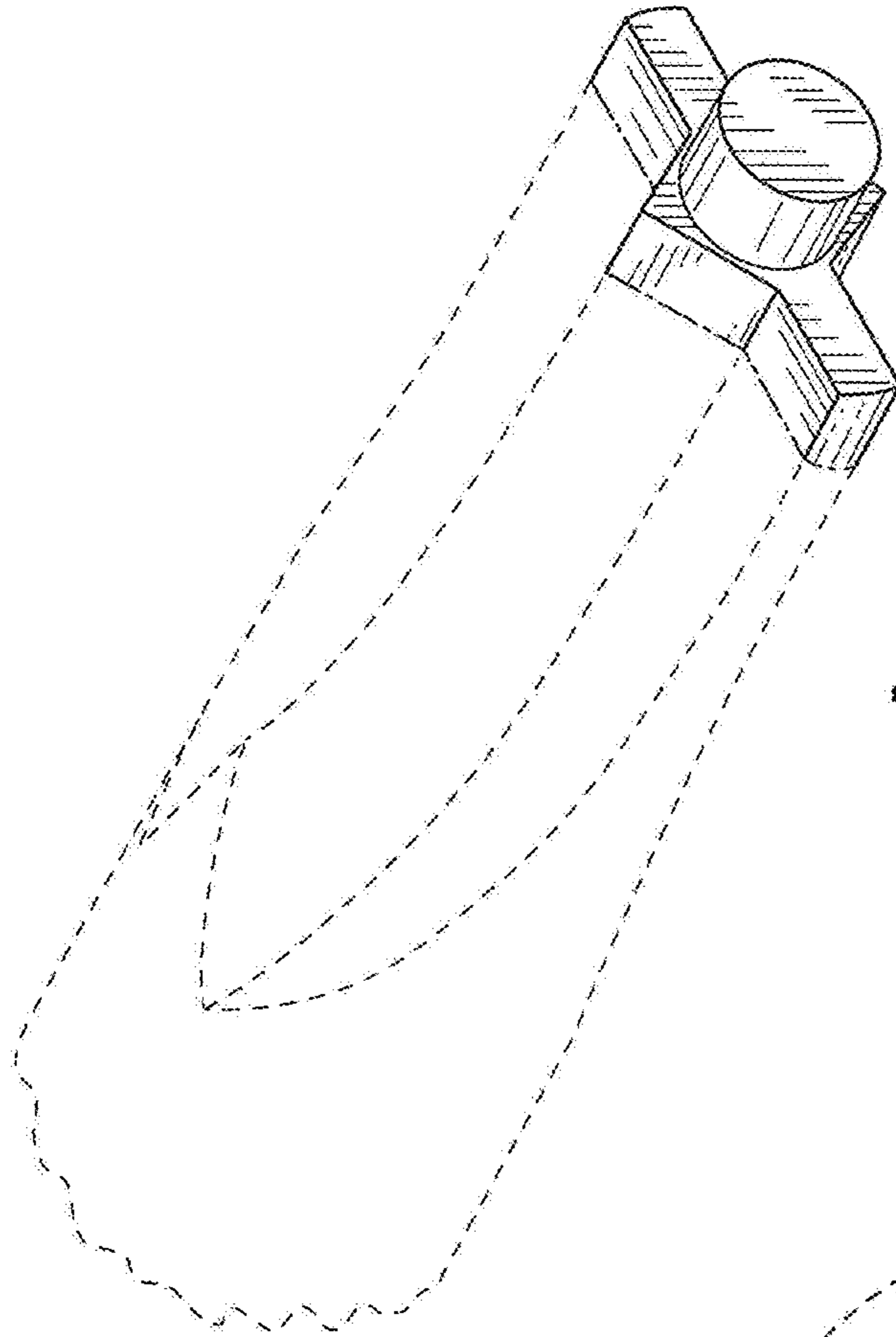

FIG. 1

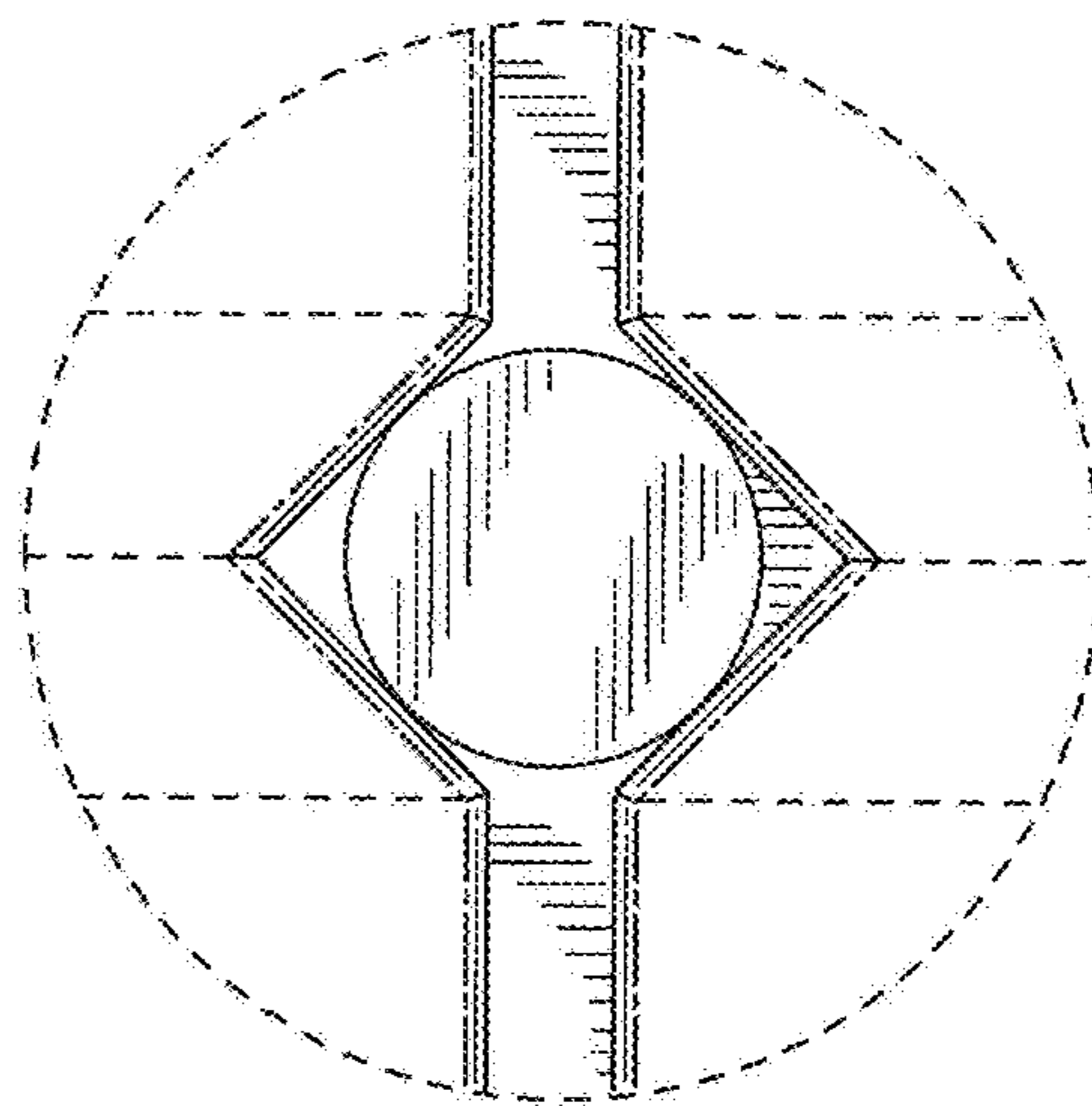

FIG. 2

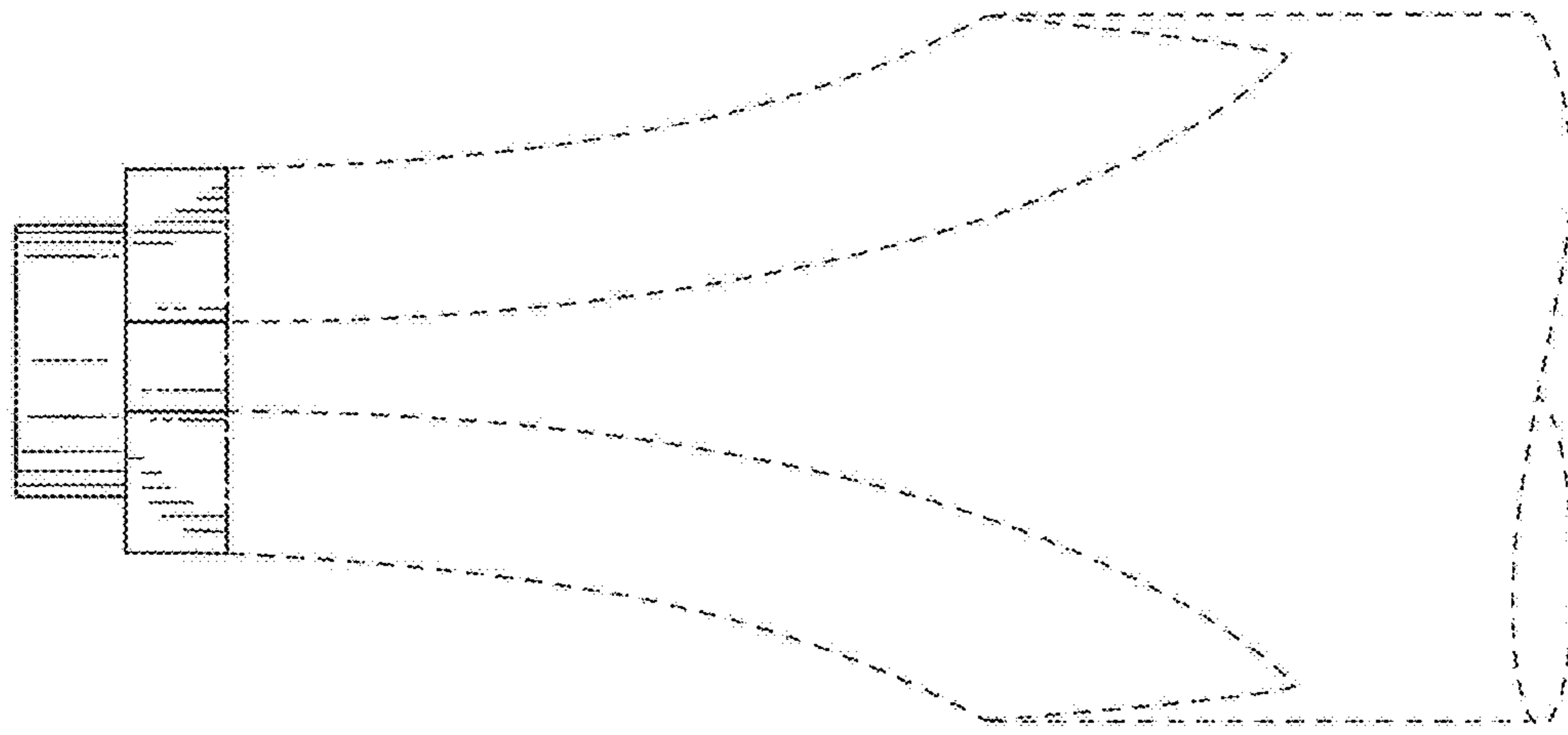

FIG. 3

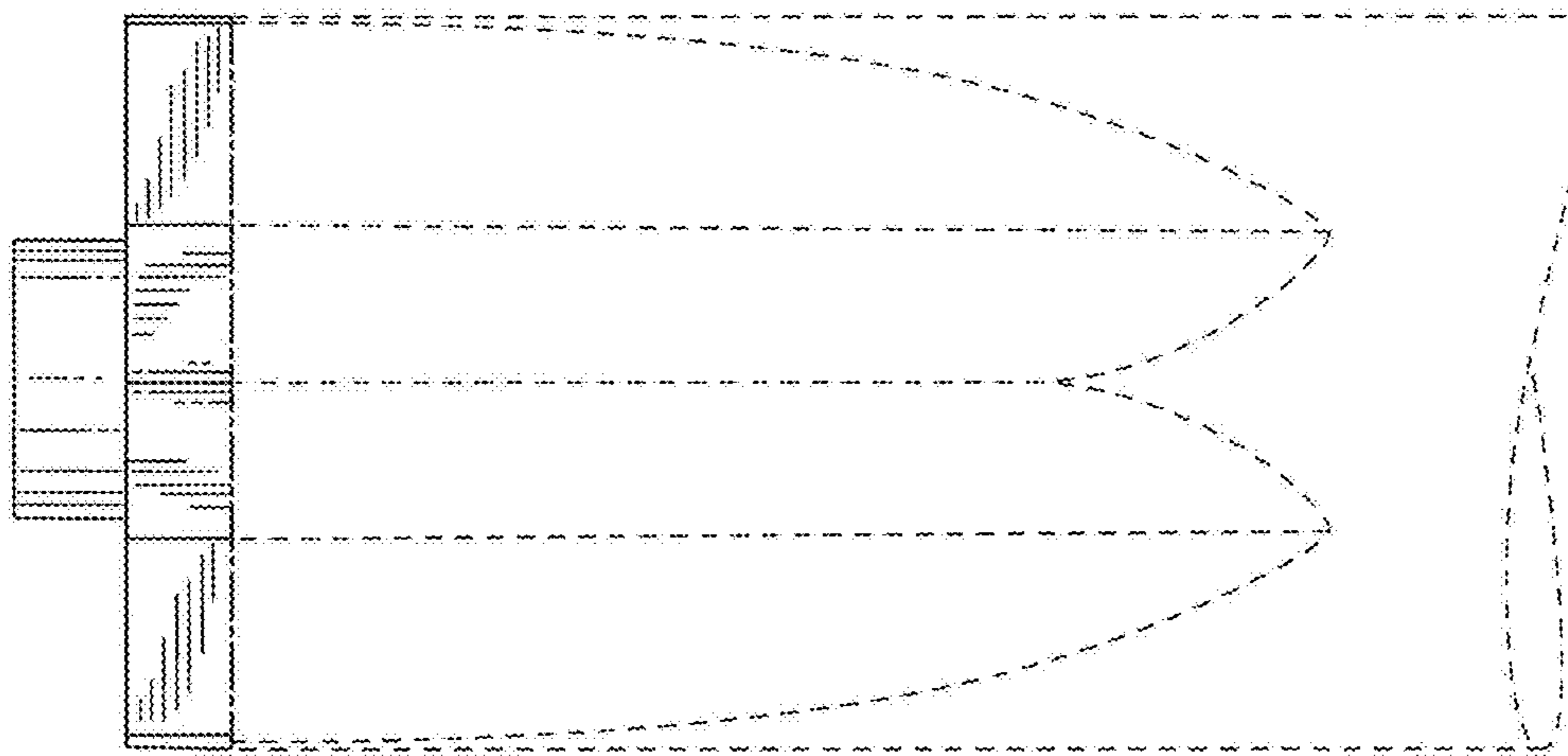

FIG. 4