

US00D826279S

(12) **United States Design Patent** (10) **Patent No.:** **US D826,279 S**
Vaninetti et al. (45) **Date of Patent:** **** Aug. 21, 2018**

(54) **ENGINE COVER**

(71) Applicant: **Brunswick Corporation**, Lake Forest, IL (US)

(72) Inventors: **Travis J. Vaninetti**, Los Gatos, CA (US); **Todd D. Dannenberg**, Fond du Lac, WI (US)

(73) Assignee: **Brunswick Corporation**, Mettawa, IL (US)

(**) Term: **15 Years**

(21) Appl. No.: **29/593,919**

(22) Filed: **Feb. 14, 2017**

(51) **LOC (11) Cl.** **15-01**

(52) **U.S. Cl.**
USPC **D15/5**

(58) **Field of Classification Search**
USPC D15/1-6
CPC ... F01M 5/00; F16M 1/026; F02P 3/02; F02B 37/013

See application file for complete search history.

(56) **References Cited**

U.S. PATENT DOCUMENTS

- D375,101 S * 10/1996 Icenogle 440/66
- 6,263,850 B1 * 7/2001 Winmill F02B 27/02
123/184.21
- D512,438 S * 12/2005 Matsunami D15/5
- D527,023 S * 8/2006 Terazono D15/5

(Continued)

OTHER PUBLICATIONS

Seaboard Marine, "Cummins QSB 6.7 Specifications," website, available at least as early as Jan. 2013, p. 4, available at <http://www.sbmar.com/engine-info/cummins-qsb6-7-specifications/>, last accessed Feb. 10, 2017.

(Continued)

Primary Examiner — T Chase Nelson

Assistant Examiner — Ania Aman

(74) *Attorney, Agent, or Firm* — Andrus Intellectual Property Law, LLP

(57) **CLAIM**

The ornamental design for an engine cover, as shown and described.

DESCRIPTION

FIG. 1 is a top plan view of a first embodiment of an engine cover according to our new and ornamental design, showing the engine cover on an engine;

FIG. 2 is a front perspective view thereof, showing the engine cover in isolation;

FIG. 3 is a rear perspective view thereof;

FIG. 4 is a top plan view thereof;

FIG. 5 is a bottom plan view thereof;

FIG. 6 is a left side elevation view thereof;

FIG. 7 is a right side elevation view thereof;

FIG. 8 is a front elevation view thereof;

FIG. 9 is a rear elevation view thereof; and,

FIG. 10 is a top plan view of a second embodiment of an engine cover according to our new and ornamental design.

The broken line showing of an engine in FIG. 1 is meant to illustrate environment for the engine cover and thus forms no part of the claimed design. The broken lines between the solid and broken line portions of the engine cover are boundaries of the claimed design, and as such, form no part of the claimed design. The broken lines beyond the boundaries of the claimed design are portions of the engine cover that form no part of the claimed design. The black areas on the second embodiment of the engine cover in FIG. 10 are meant to indicate flat surface ornamentation having a contrasting color from the remainder of the engine cover. The second embodiment of the engine cover is identical to the first embodiment of the engine cover in all respects, except for inclusion of the flat surface ornamentation as shown in FIG. 10.

1 Claim, 8 Drawing Sheets

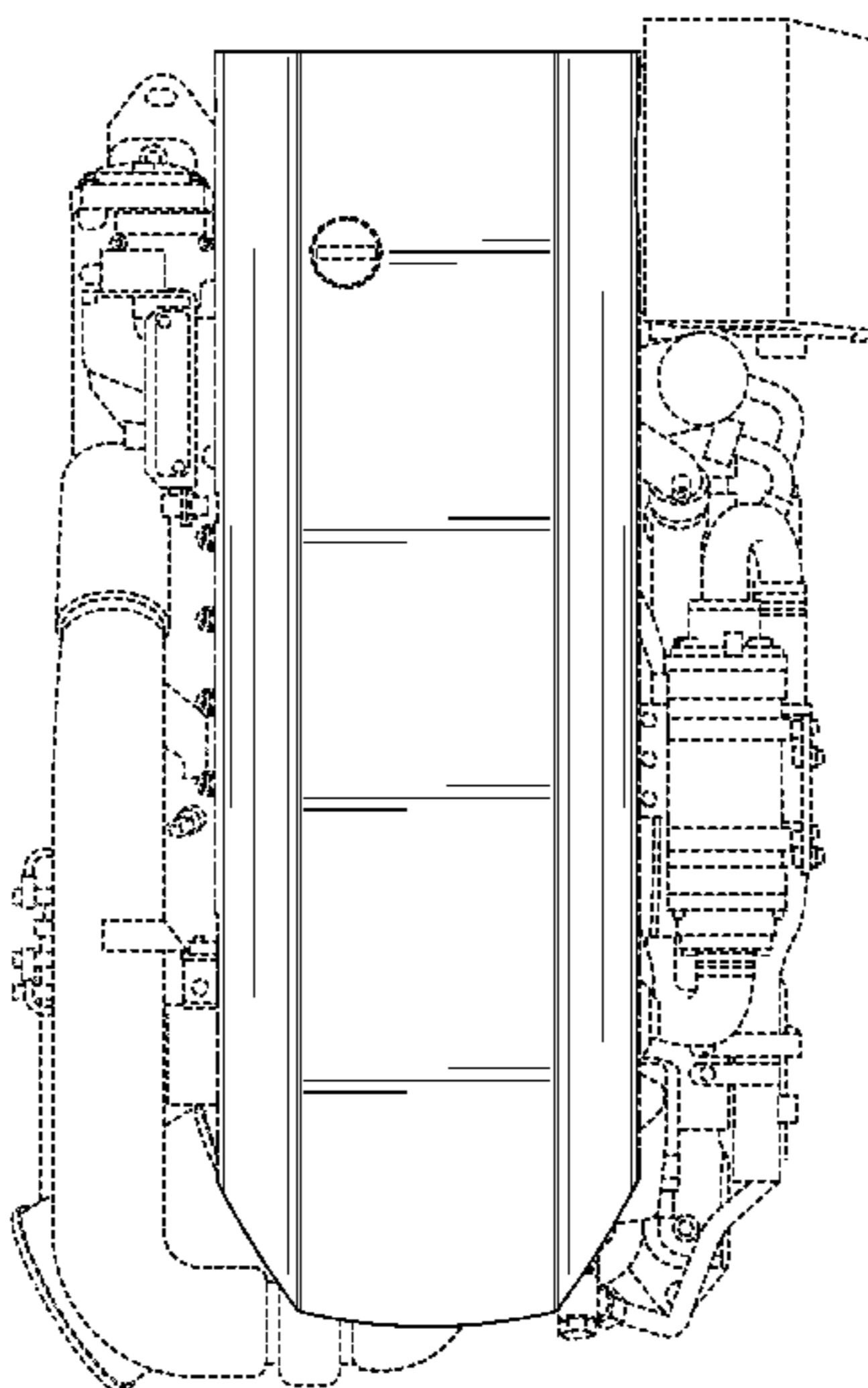

(56)

References Cited

U.S. PATENT DOCUMENTS

7,137,378 B1 * 11/2006 Jaeger F02D 9/1035
 123/198 D
 D541,303 S * 4/2007 Drew D15/5
 D754,753 S * 4/2016 Kiyoyuki D15/4
 D774,113 S * 12/2016 Underhill D15/31
 D775,234 S * 12/2016 Okuyama D15/5
 9,527,568 B1 * 12/2016 Belter B63H 21/383
 D777,791 S * 1/2017 Okuyama D15/1
 9,551,307 B1 * 1/2017 Hamzeh F02M 35/10354
 2002/0011222 A1 * 1/2002 Bilek F01B 1/12
 123/52.1
 2009/0130417 A1 * 5/2009 Maeda C08L 77/06
 428/220
 2009/0179460 A1 * 7/2009 Peterson B60R 13/0861
 296/193.11
 2017/0152818 A1 * 6/2017 Newman F02M 35/104

OTHER PUBLICATIONS

Ritchie, Craig, "Mercury Marine Launches New 6.7L Diesel," website, Feb. 15, 2015, p. 1, available at <http://www.boat.com/news/mercury-marine-launches-new-6-7l-diesel>, last accessed Feb. 10, 2017.

John Deere US, "Power Tech 9.0L Marine Propulsion Engine," website, available at https://www.deere.com/en_US/products/engines_and_drivetrain/marine/propulsion_certified/6090_series/6090SFM85_A.page, last accessed Feb. 10, 2017.

The Crowley Advisor, "Boating In-Season Check List," website showing photograph of Volvo Penta D6, May 31, 2012, p. 4, available at http://crowleysyachtyard.blogspot.com/2012_05_01_archive.html, last accessed Feb. 10, 2017.

Western Branch Diesel, "Volvo Penta Heavy Duty Propulsion," website showing photograph of Volvo Penta D9, p. 3, available at <http://www.westernbranchdiesel.com/brands/volvo-penta/>, last accessed Feb. 10, 2017.

Marine Power, "Yanmar Inboard Engine 530hp/390kW," website, available at http://www.marine-power.co.uk/index.php?route=product/product&product_id=773, last accessed Feb. 10, 2017.

Mercury Marine, "Mercury Mercruiser Inboards," website, available at <https://www.mercurymarine.com/en/us/engines/inboard-and-sterndrive/mercruiser/inboards/>, last accessed Feb. 14, 2017.

Mercury Marine, "Mercury Mercruiser 6.2L," website, available at <https://www.mercurymarine.com/en/us/engines/inboard-and-sterndrive/mercruiser/62l/>, last accessed Feb. 14, 2017.

Mercury Marine, "Mercury Mercruiser 4.5L," website, available at <https://www.mercurymarine.com/en/us/engines/inboard-and-sterndrive/mercruiser/45l/>, last accessed Feb. 14, 2017.

* cited by examiner

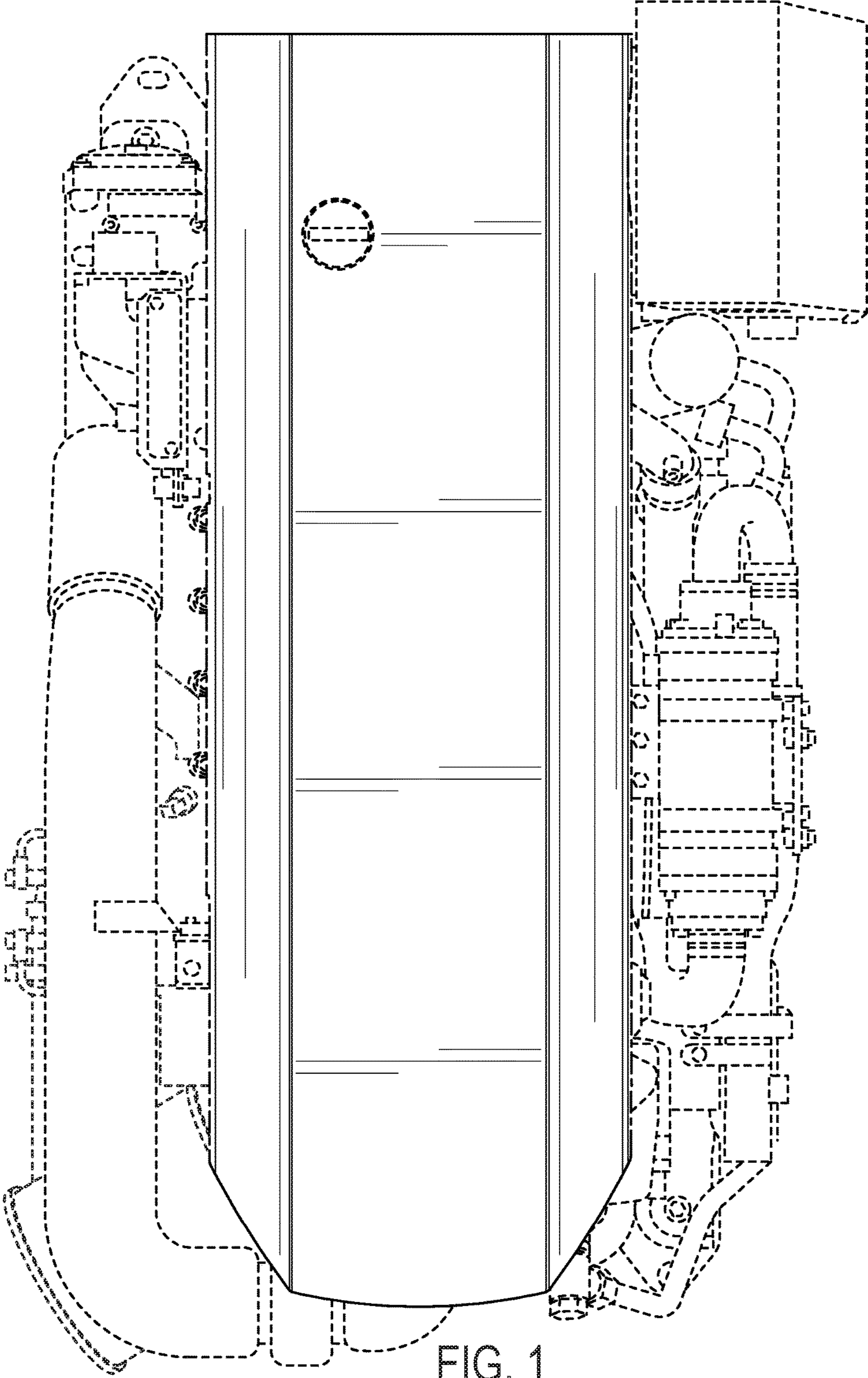

FIG. 1

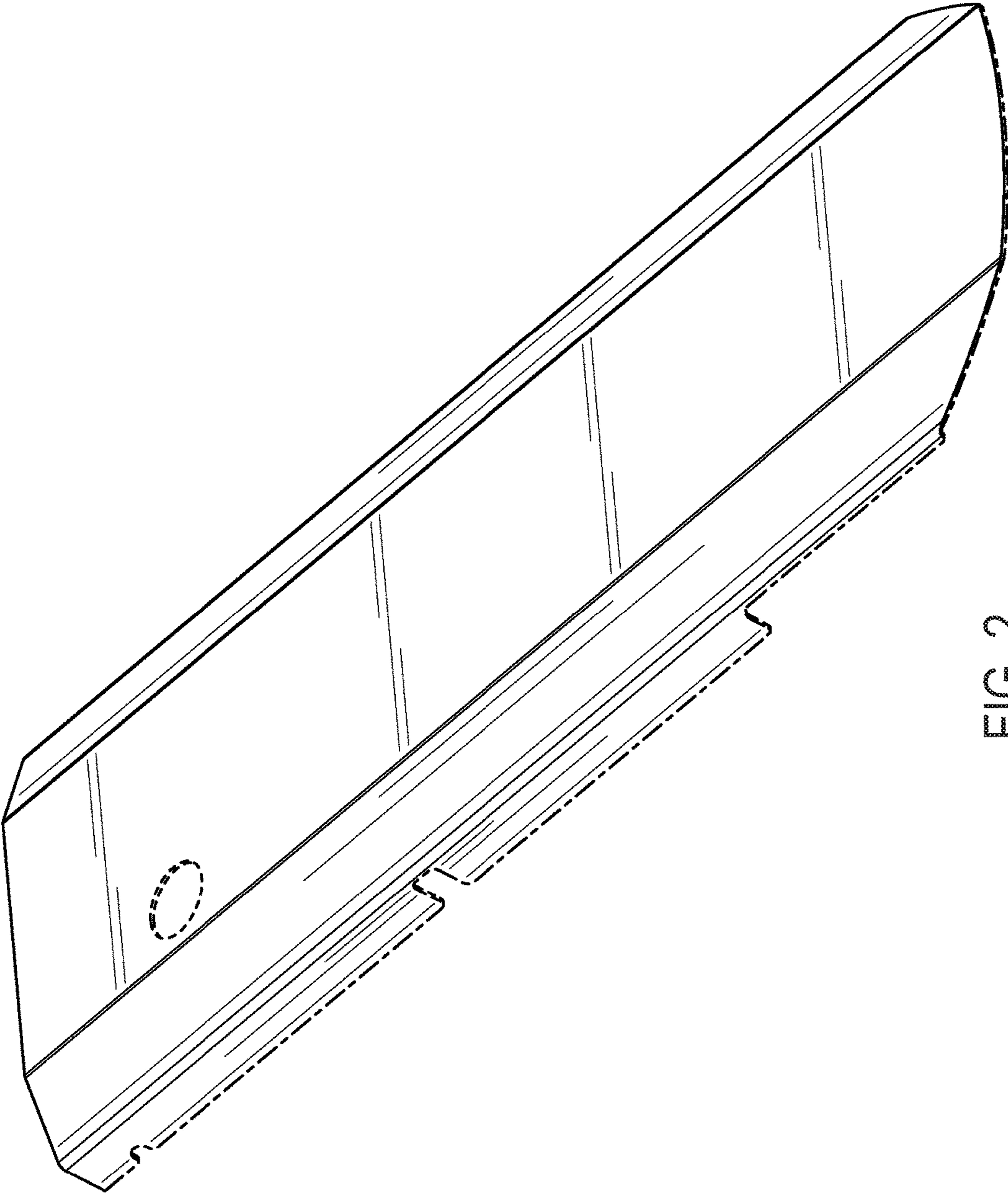

FIG. 2

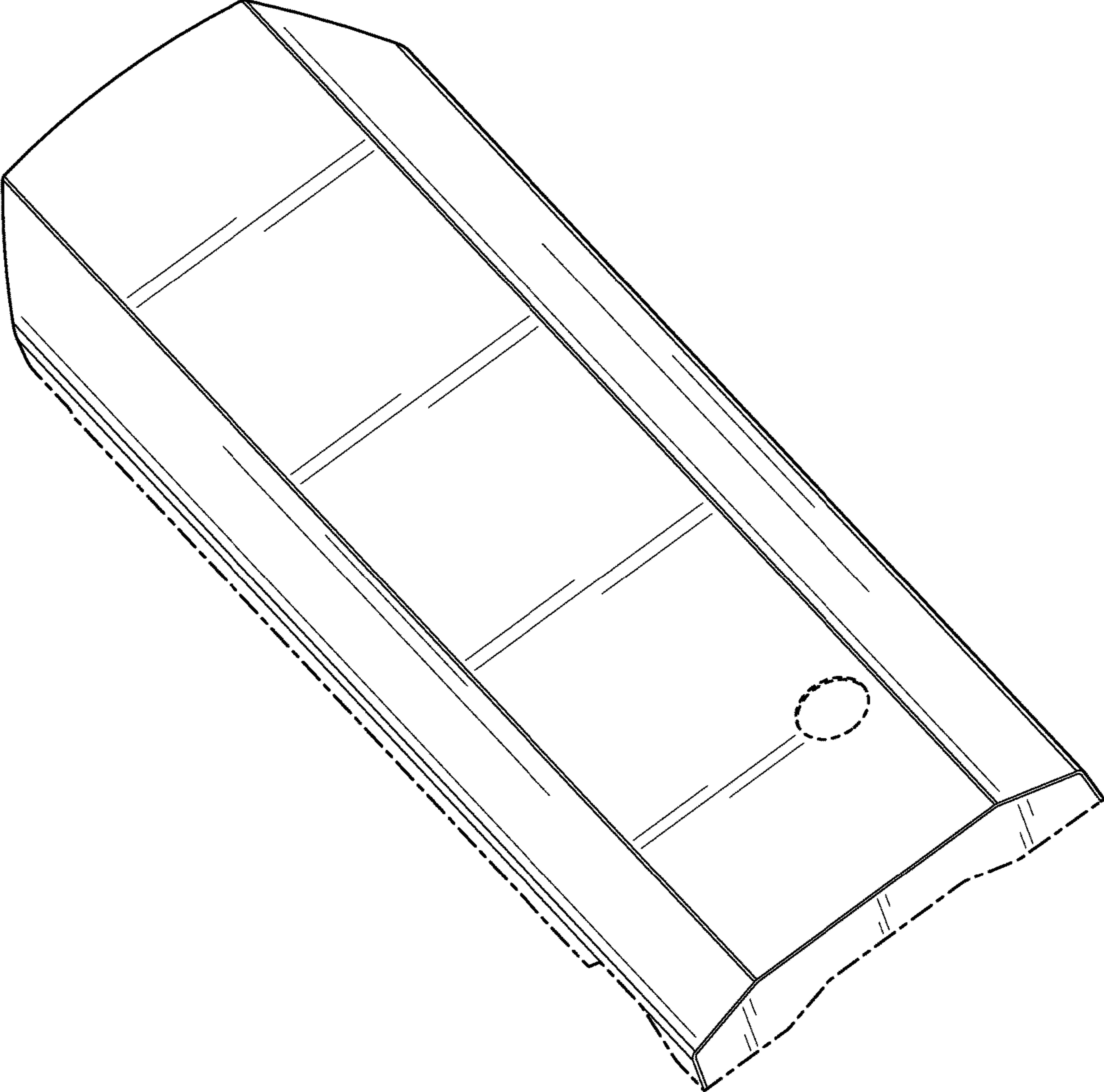

FIG. 3

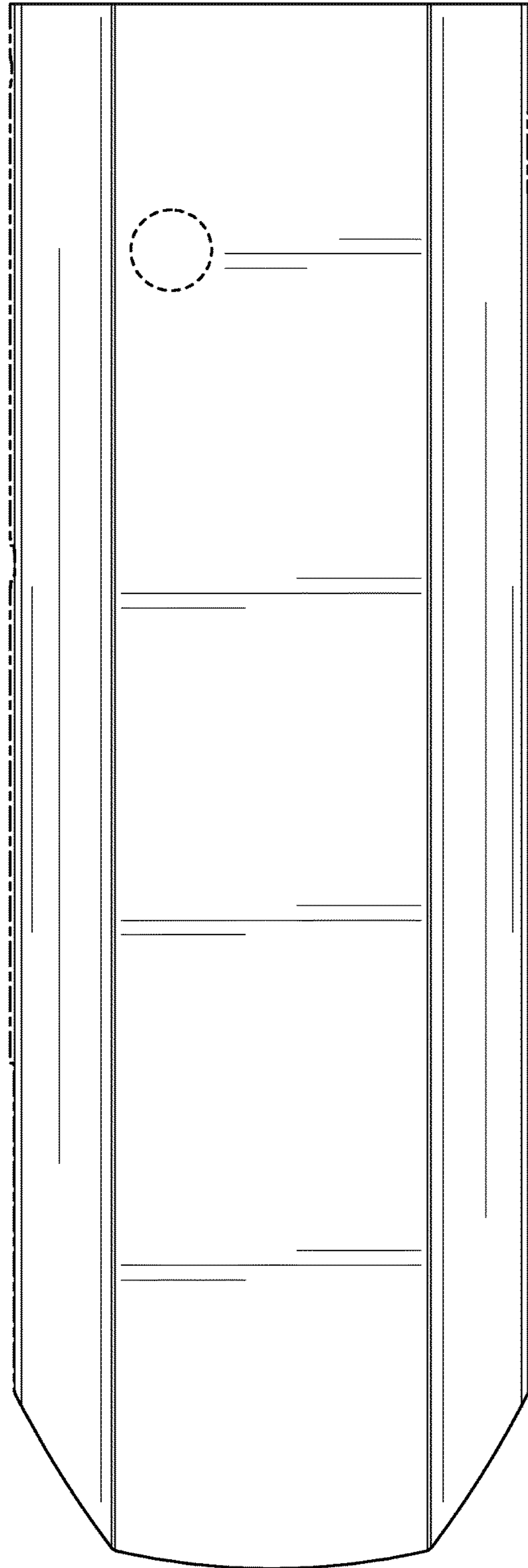

FIG. 4

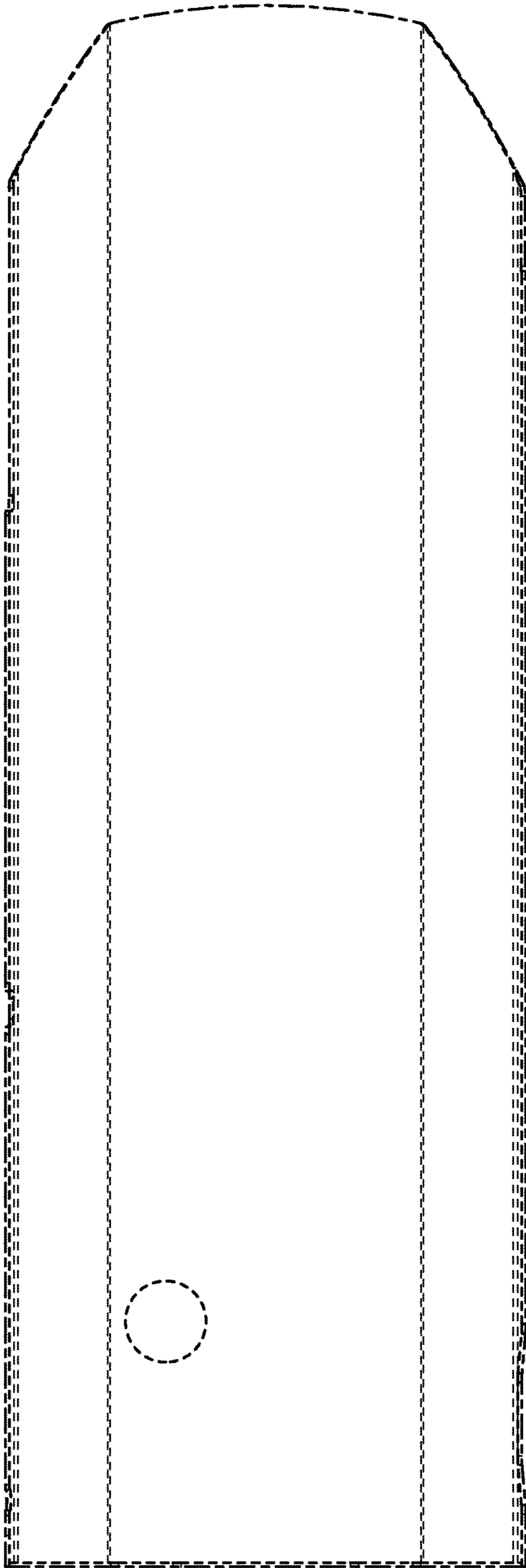

FIG. 5

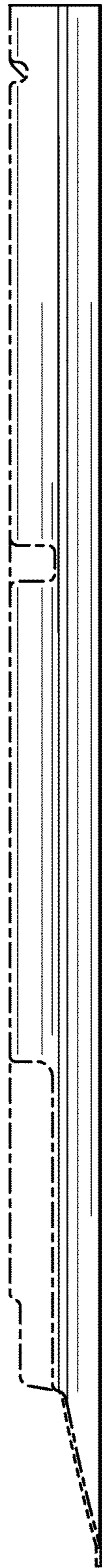

FIG. 6

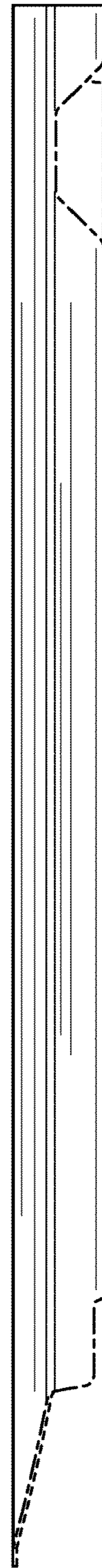

FIG. 7

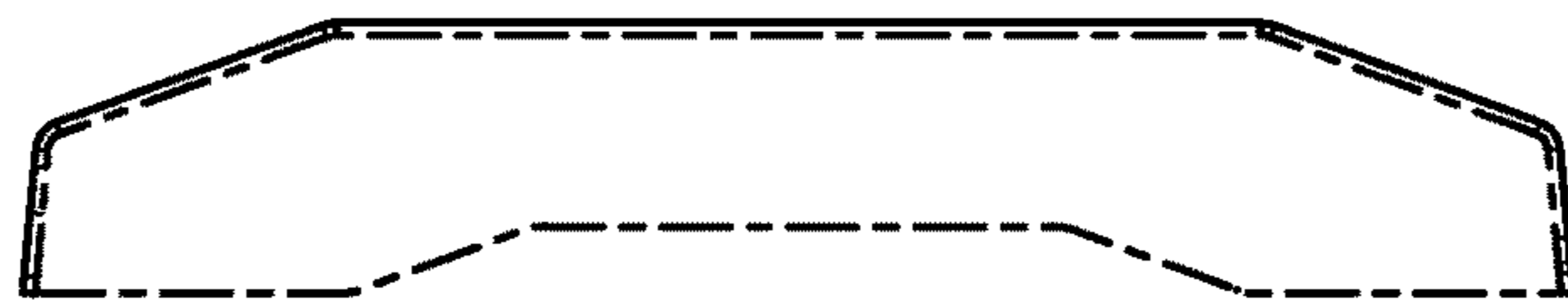

FIG. 8

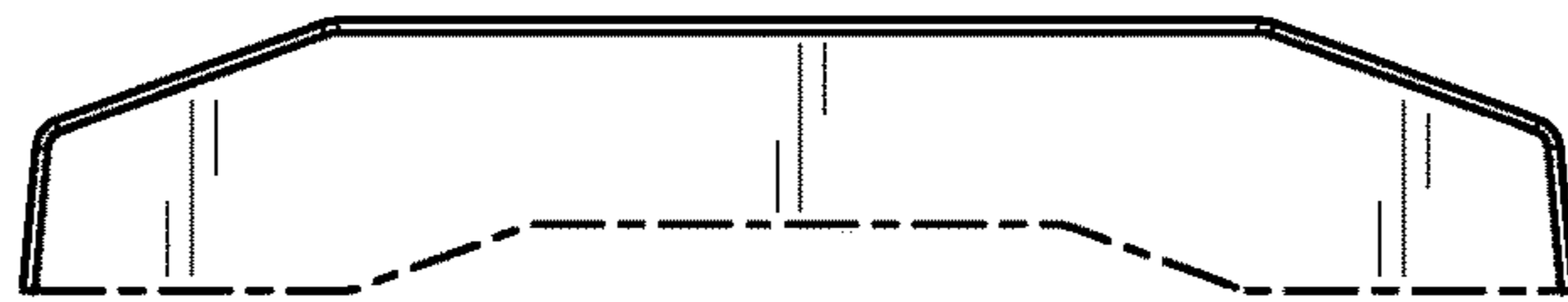

FIG. 9

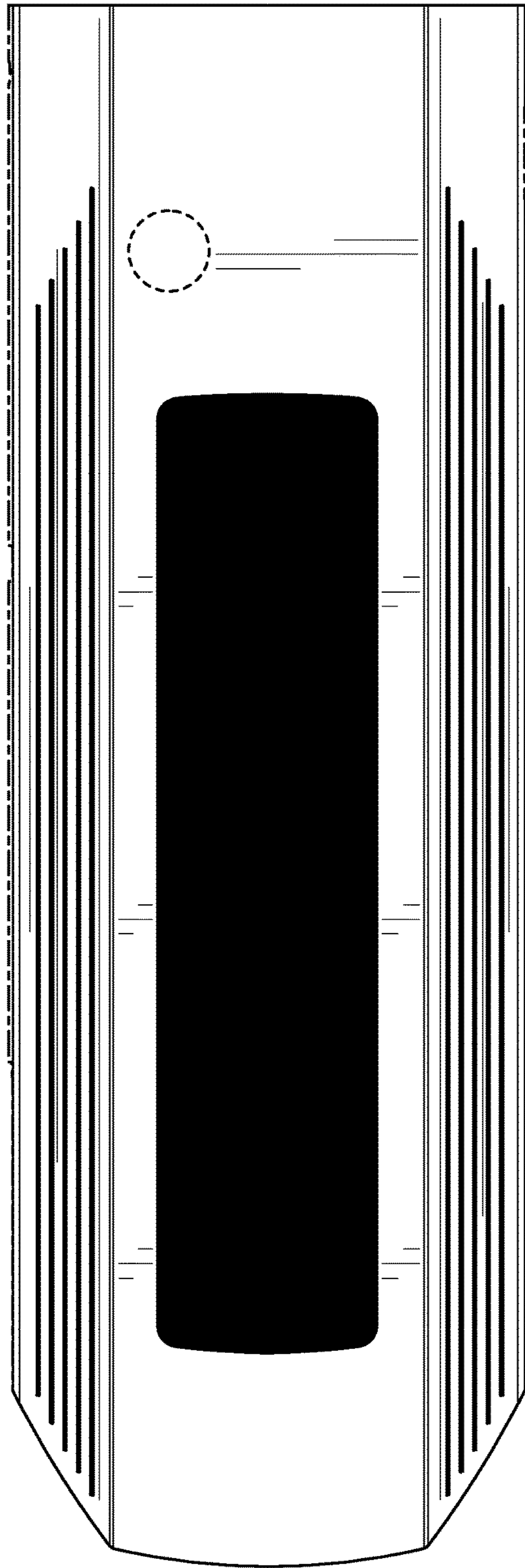

FIG. 10