



US00D826177S

(12) **United States Design Patent** (10) **Patent No.:** **US D826,177 S**  
**Nelson** (45) **Date of Patent:** **\*\* Aug. 21, 2018**

(54) **MOUNTED POWER STATION**

D681,058 S \* 4/2013 Yamamoto ..... D13/118  
2014/0072342 A1\* 3/2014 Iijima ..... G03G 15/757  
399/167

(71) Applicant: **Michael E. Nelson**, Jonesboro, AR  
(US)

\* cited by examiner

(72) Inventor: **Michael E. Nelson**, Jonesboro, AR  
(US)

*Primary Examiner* — Daniel Bui  
(74) *Attorney, Agent, or Firm* — Schrantz Law Firm,  
PLLC; Stephen D. Schrantz

(\*\*) Term: **15 Years**

(57) **CLAIM**

(21) Appl. No.: **29/602,665**

The ornamental design for a mounted power station, as shown and described.

(22) Filed: **May 2, 2017**

**DESCRIPTION**

(51) **LOC (11) Cl.** ..... **13-03**

(52) **U.S. Cl.**  
USPC ..... **D13/154; D13/148**

(58) **Field of Classification Search**  
USPC ..... D13/107, 110, 118, 119, 120, 123, 128,  
D13/133, 146, 147, 148, 149, 154, 184,  
D13/199; 361/500, 600, 601, 679.01, 825  
CPC ..... H02J 3/32; H02J 7/00; H02J 7/14; H01R  
3/32; H01R 13/66; H02K 53/00; F24J  
2/38

See application file for complete search history.

FIG. 1 is a front, top and left side perspective view of a mounted power station showing my new design;  
FIG. 2 is a front, bottom and left side perspective thereof;  
FIG. 3 is a top plan view thereof;  
FIG. 4 is a rear elevational view thereof;  
FIG. 5 is a front elevational view thereof;  
FIG. 6 is a left side elevational view thereof;  
FIG. 7 is a right side elevational view thereof;  
FIG. 8 is a bottom plan view thereof;  
FIG. 9 is a front, top and left side perspective view thereof, in use condition; and,  
FIG. 10 is another front, top and left side perspective view thereof, in use condition.

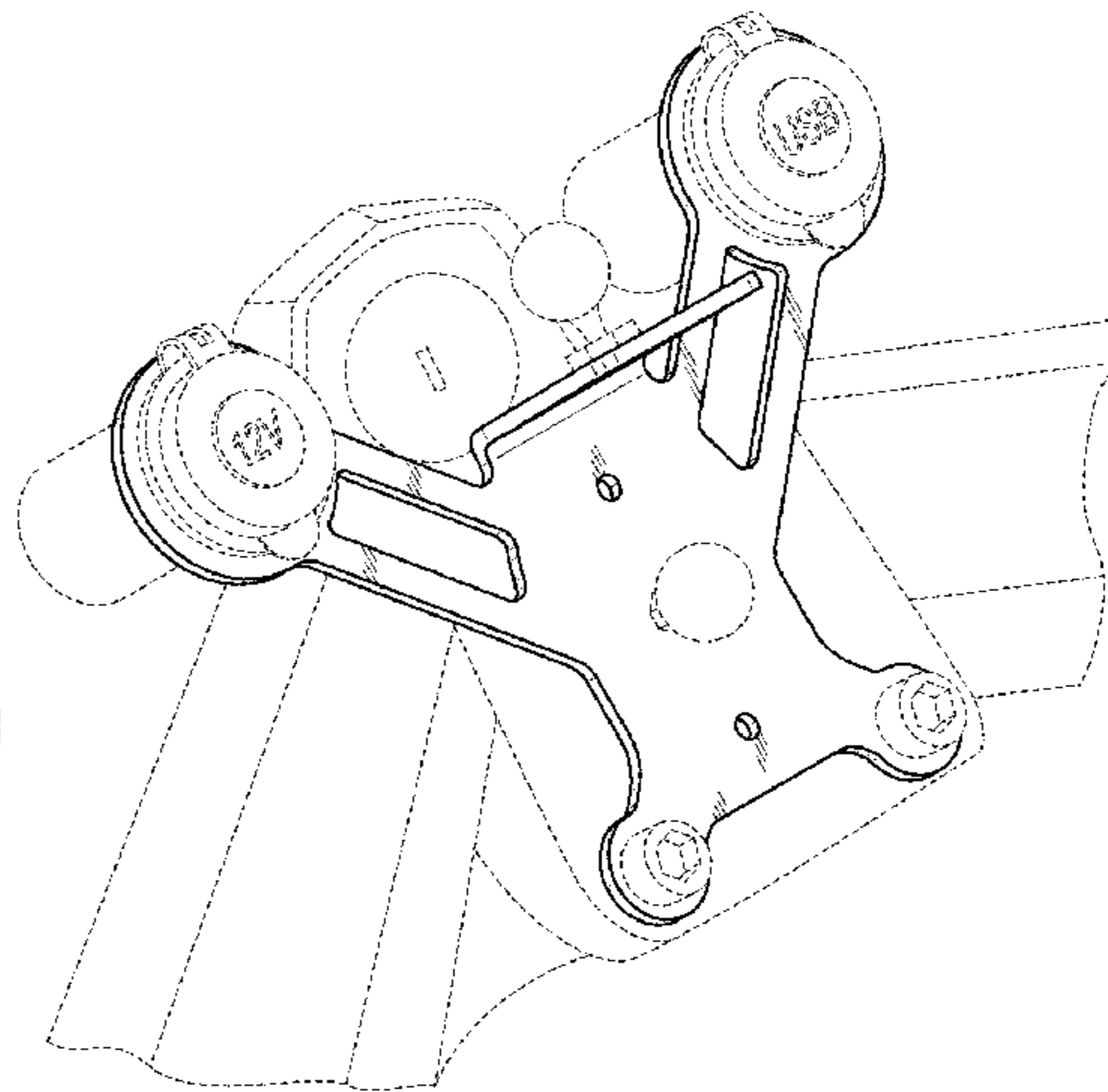
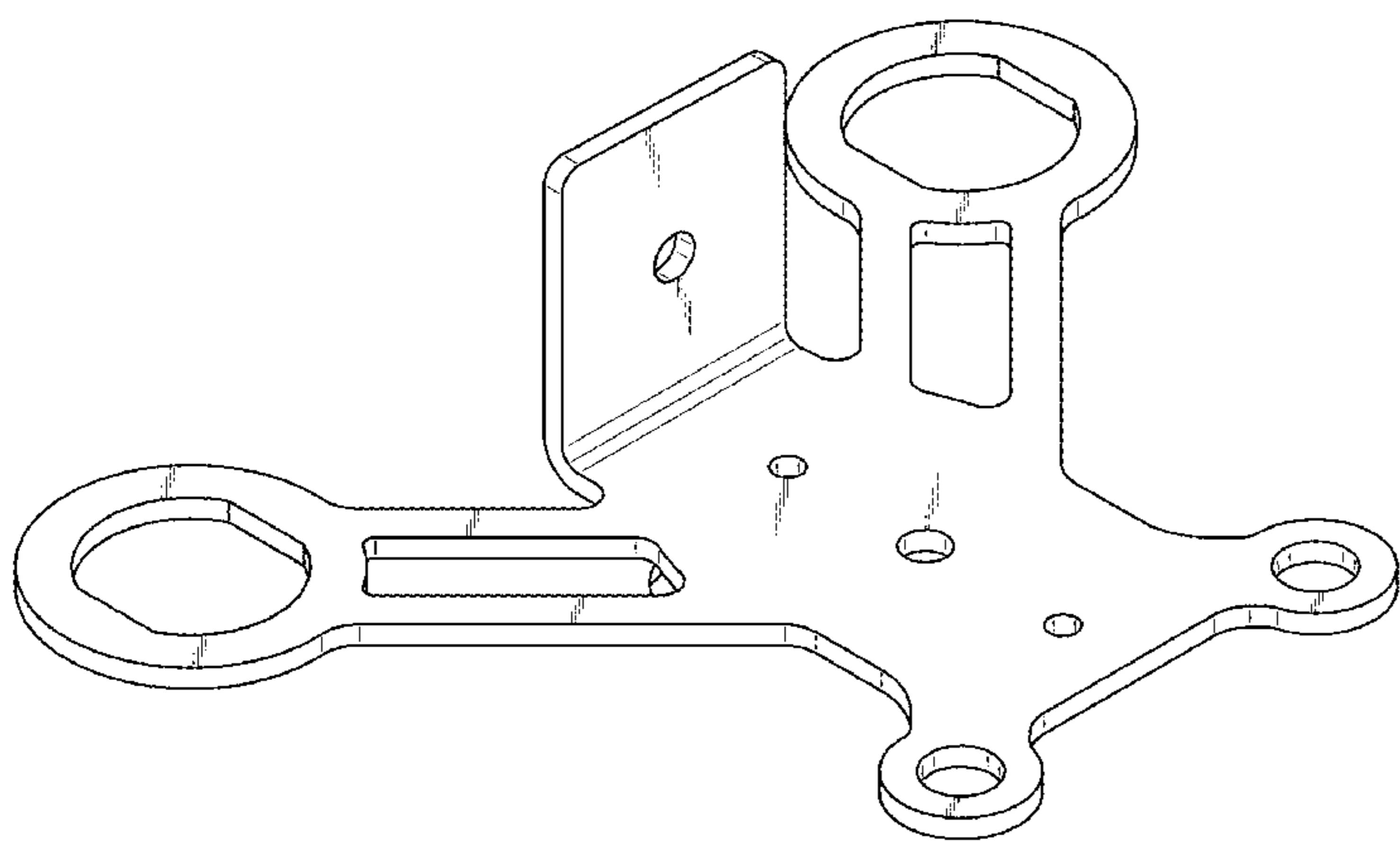
The broken line shown in FIGS. 9 and 10 is for the purpose of illustrating unclaimed environment only and forms no part of the claimed design.

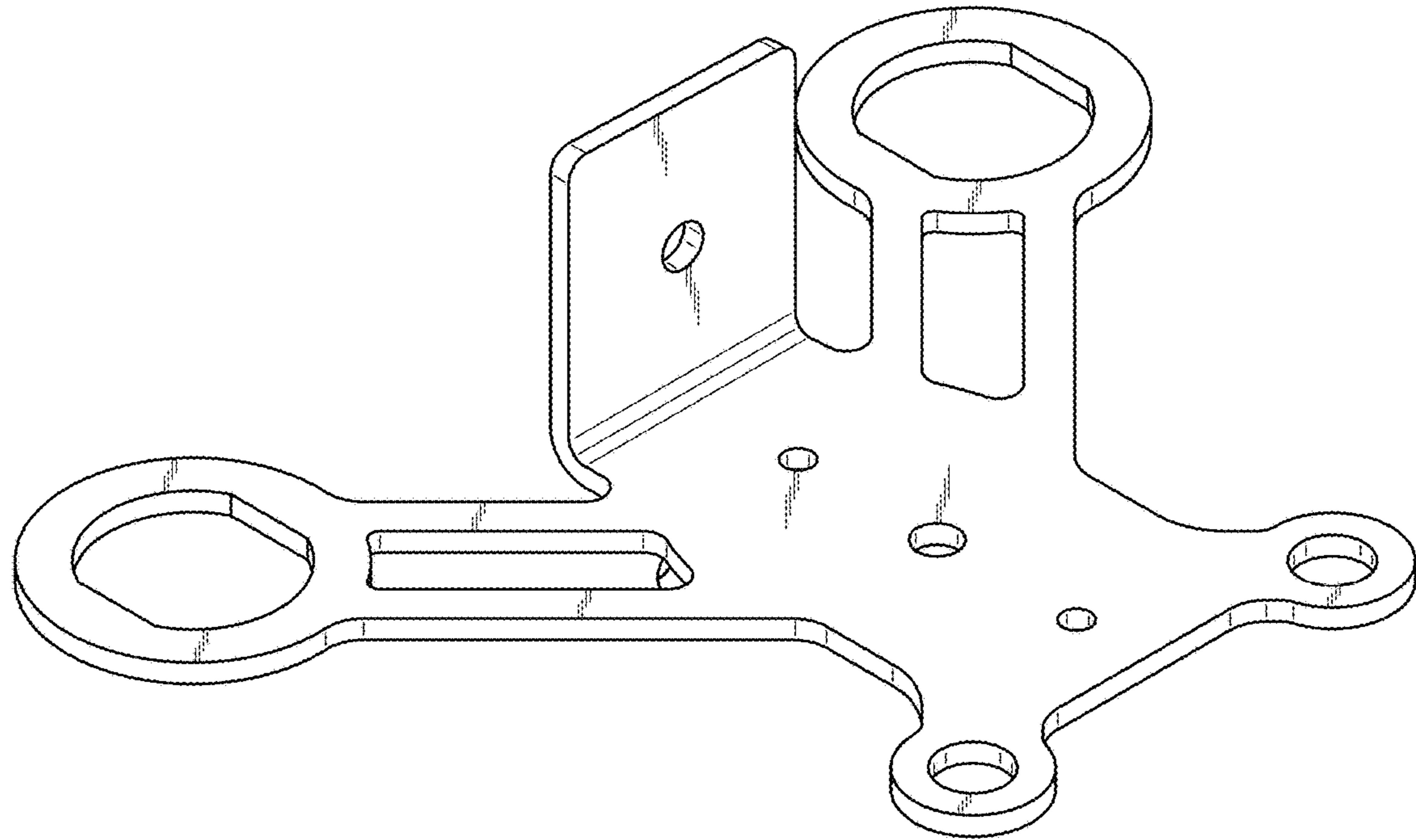
(56) **References Cited**

**U.S. PATENT DOCUMENTS**

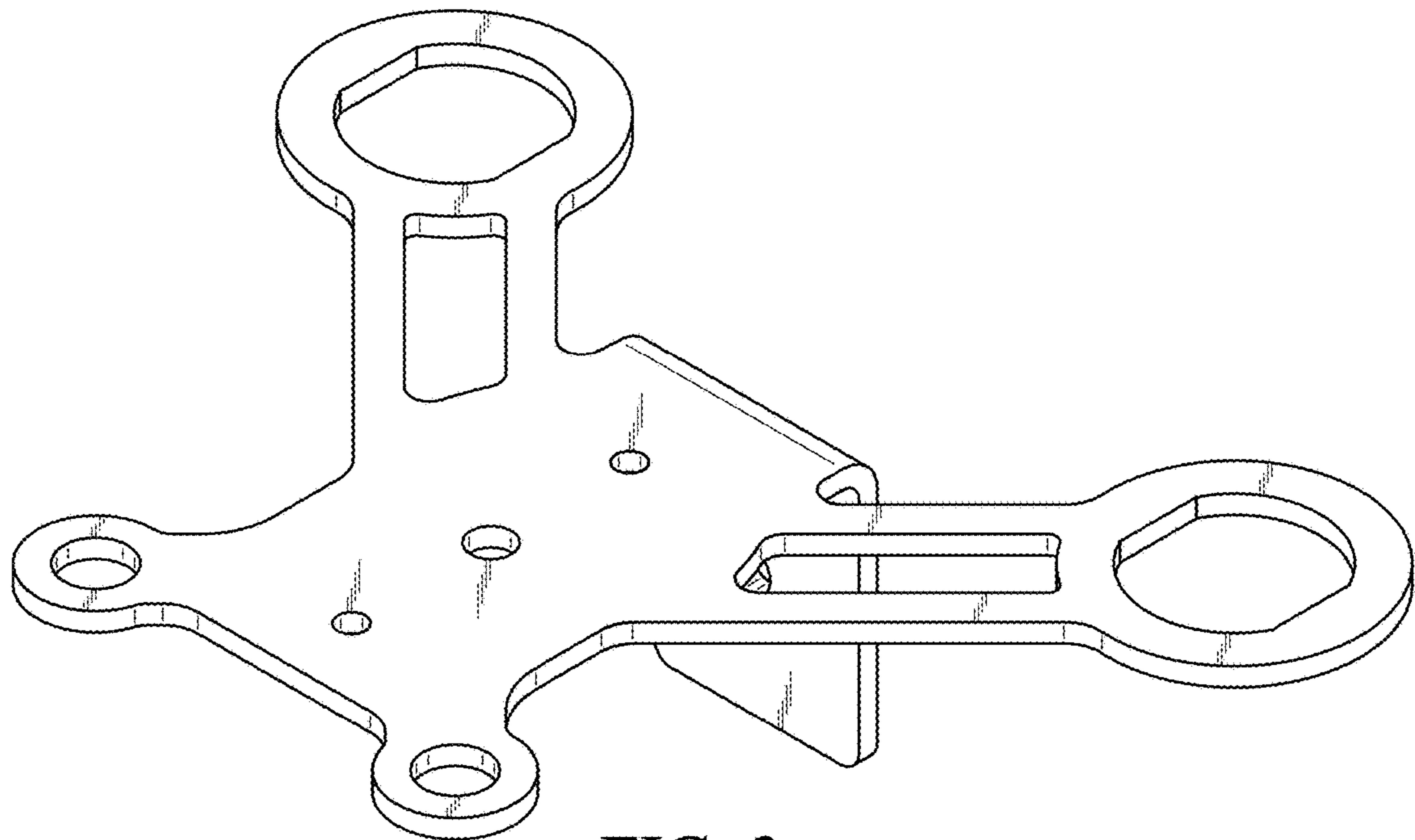
6,785,489 B2 \* 8/2004 Anderson, II ..... G03G 15/751  
399/117  
D573,947 S \* 7/2008 Kishimoto ..... D13/119

**1 Claim, 6 Drawing Sheets**

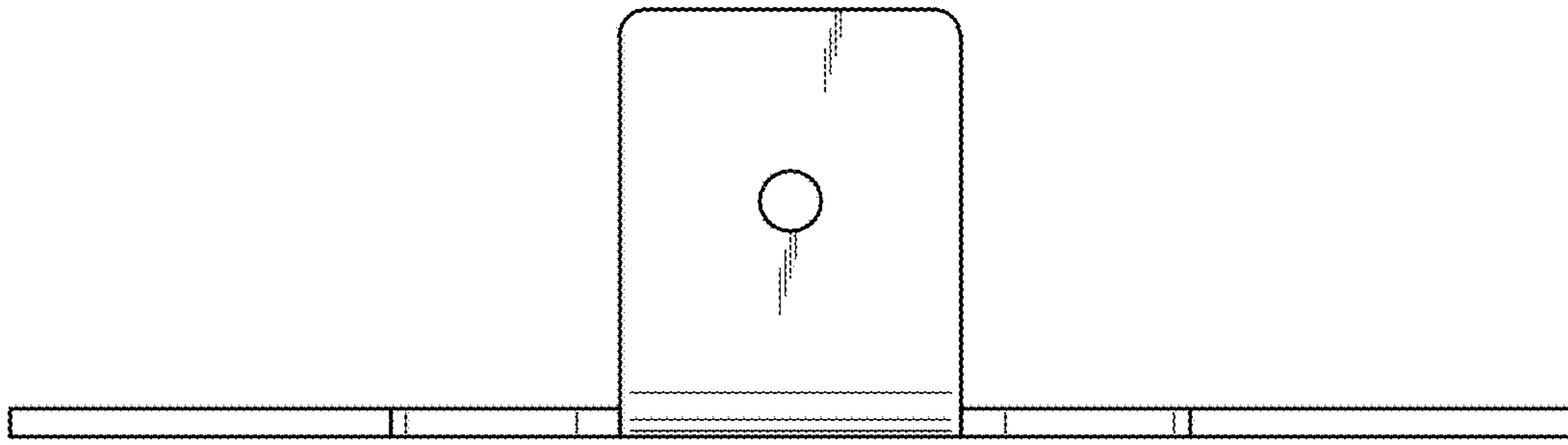




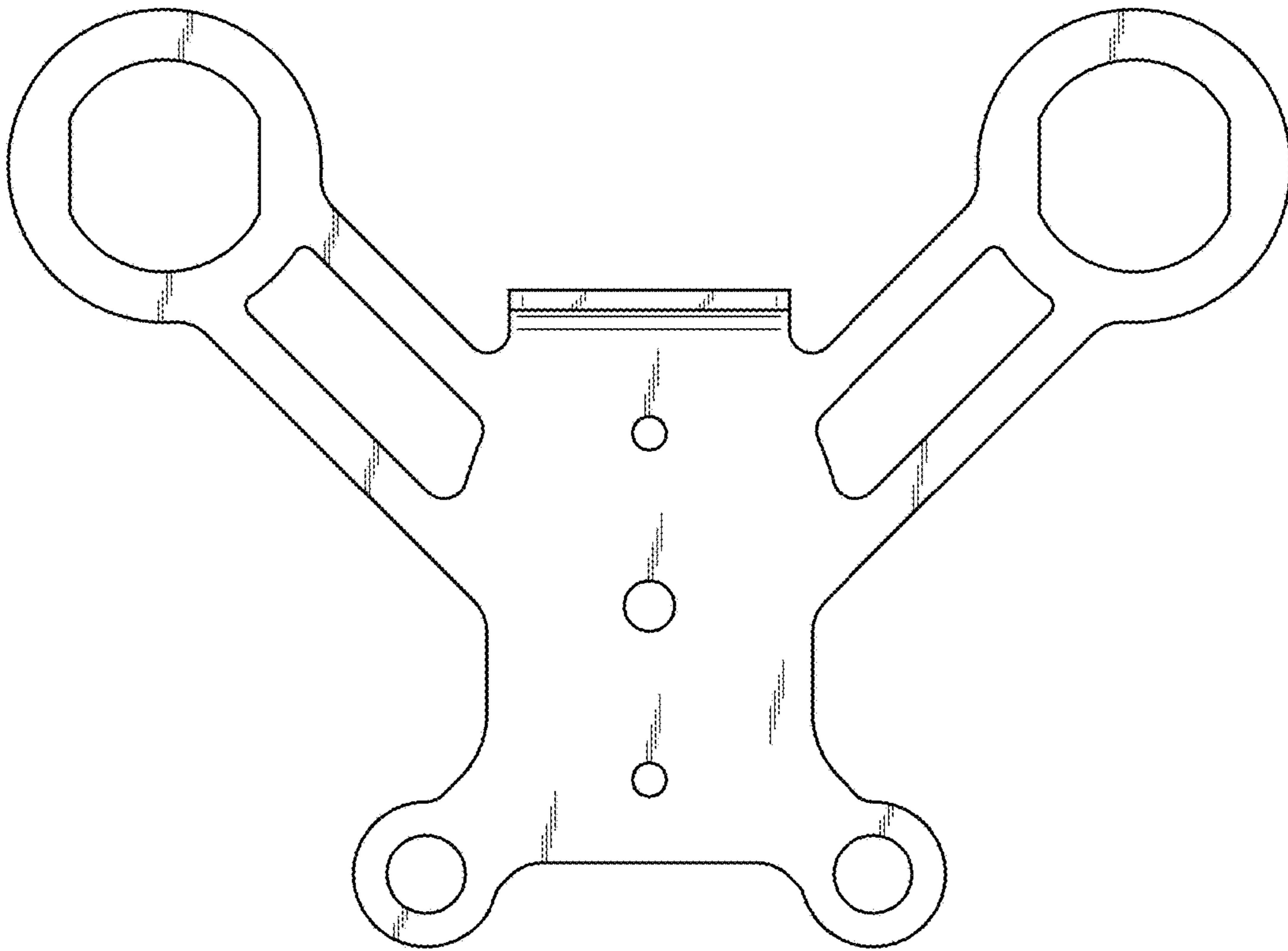
*FIG. 1*



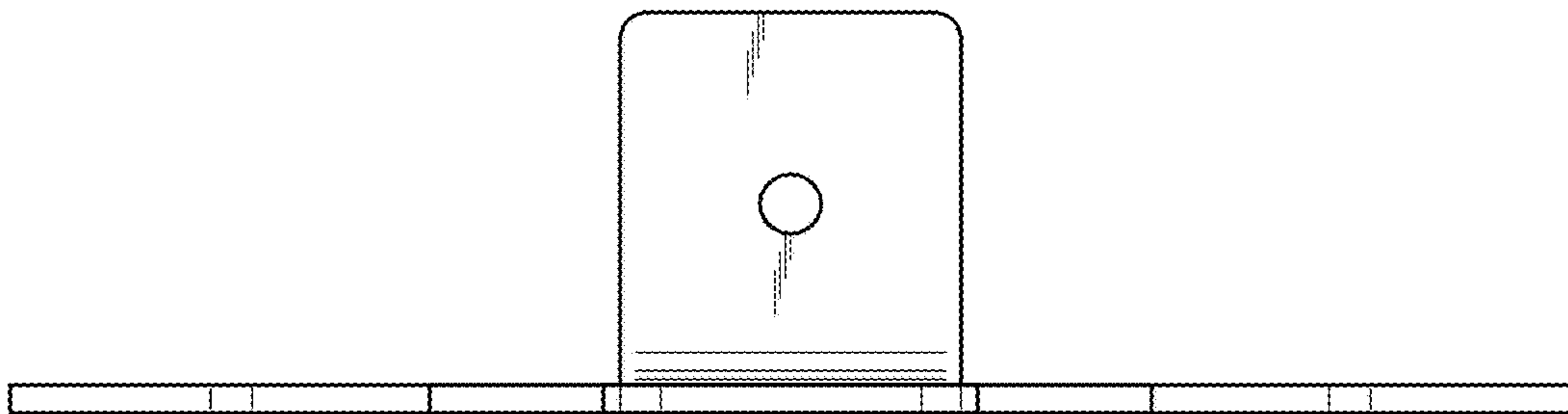
*FIG. 2*



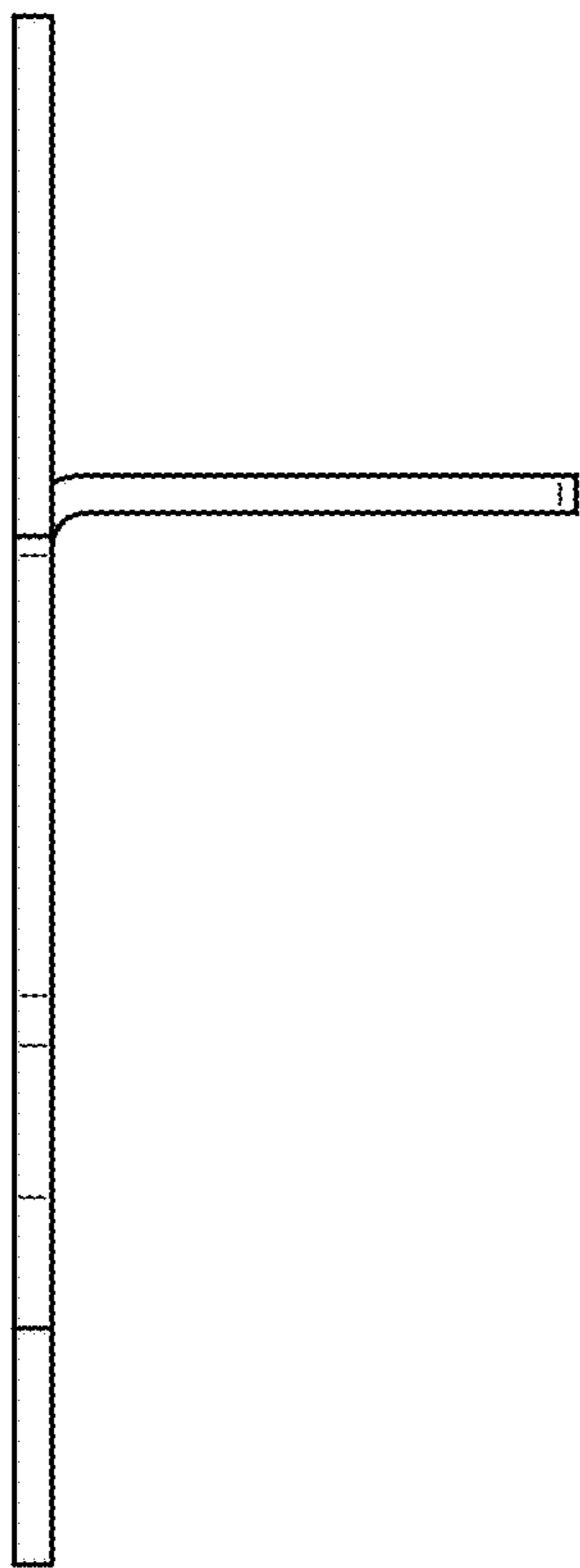
*FIG. 4*



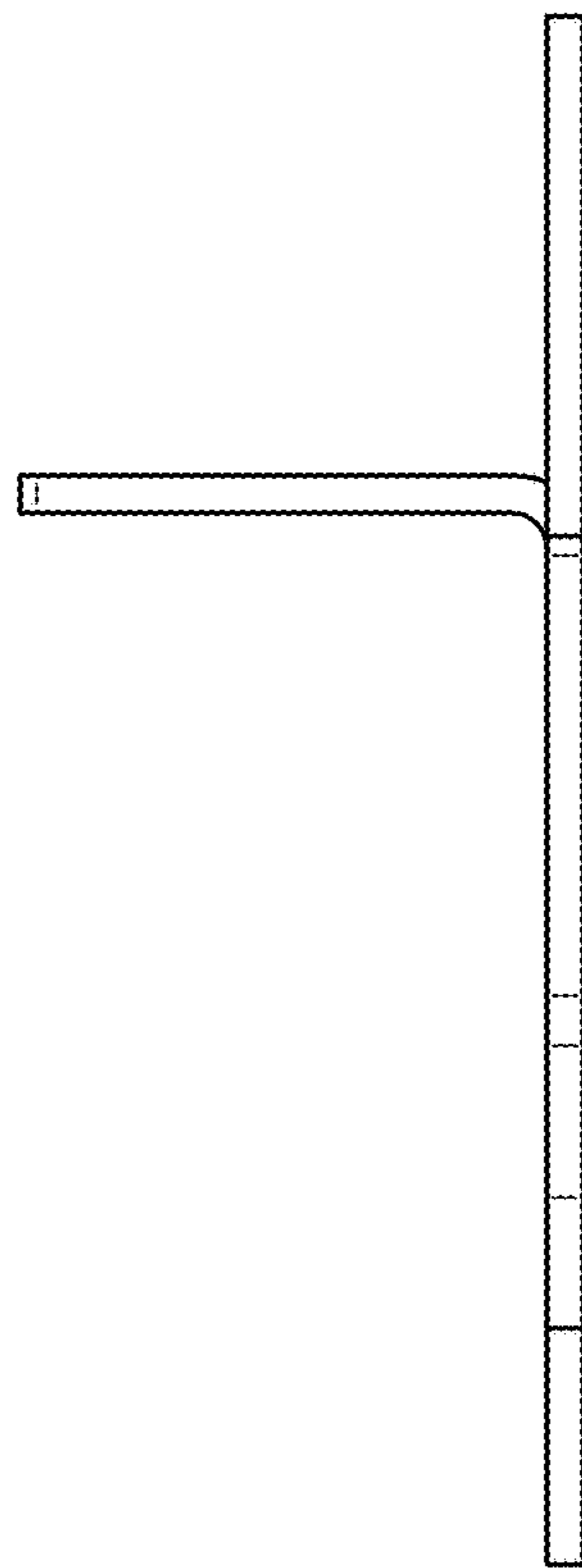
*FIG. 3*



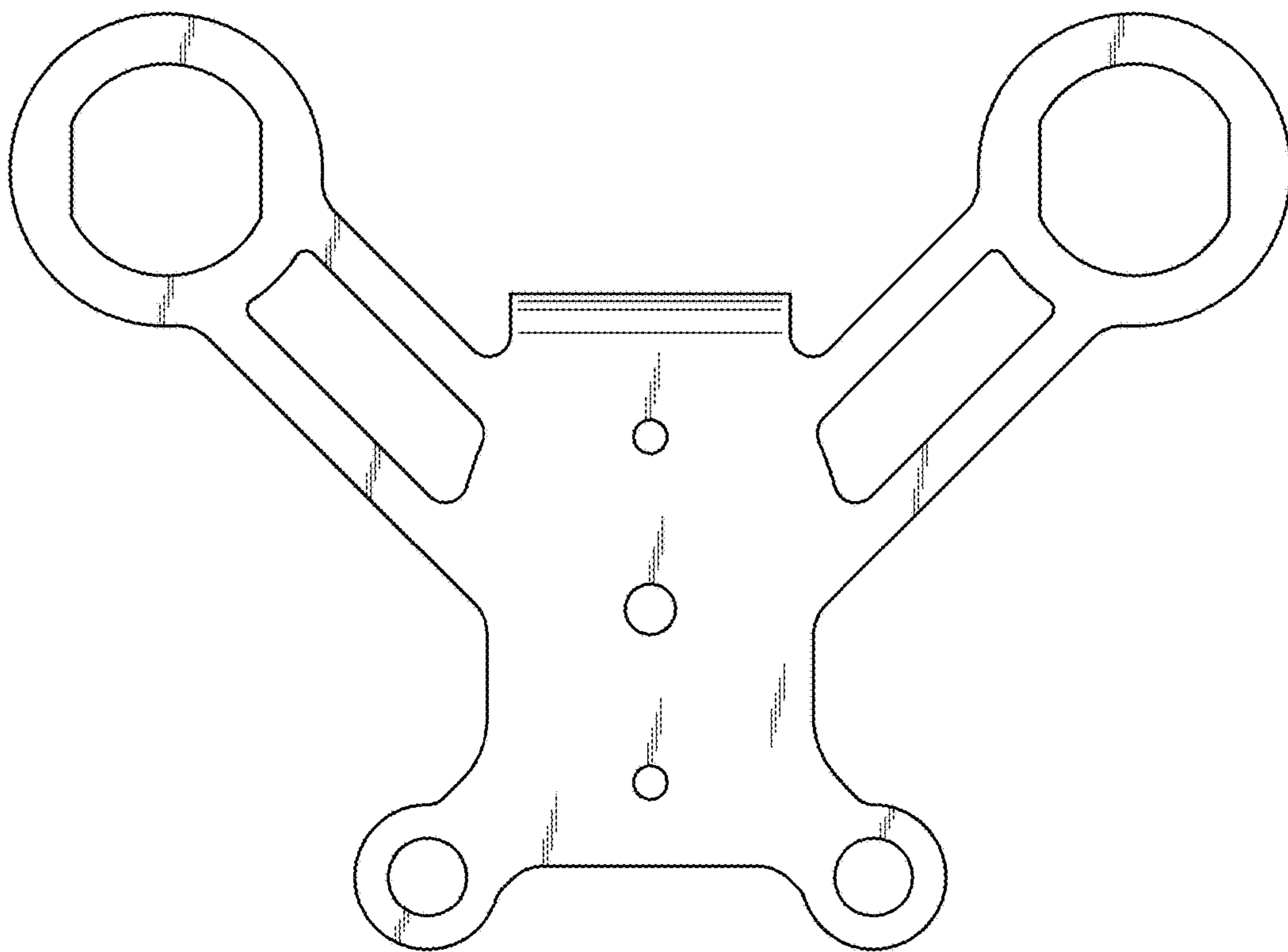
*FIG. 5*



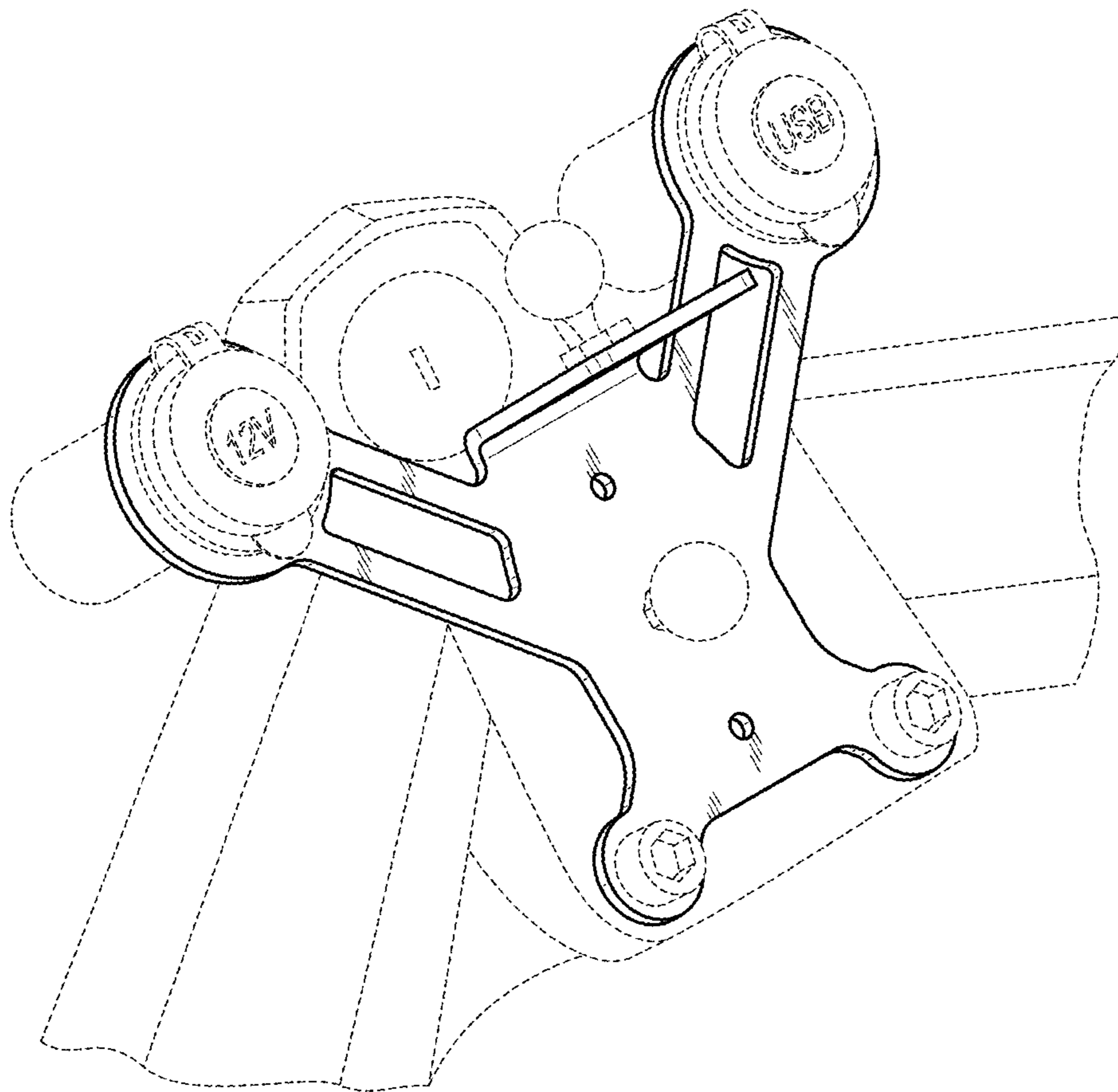
*FIG. 6*



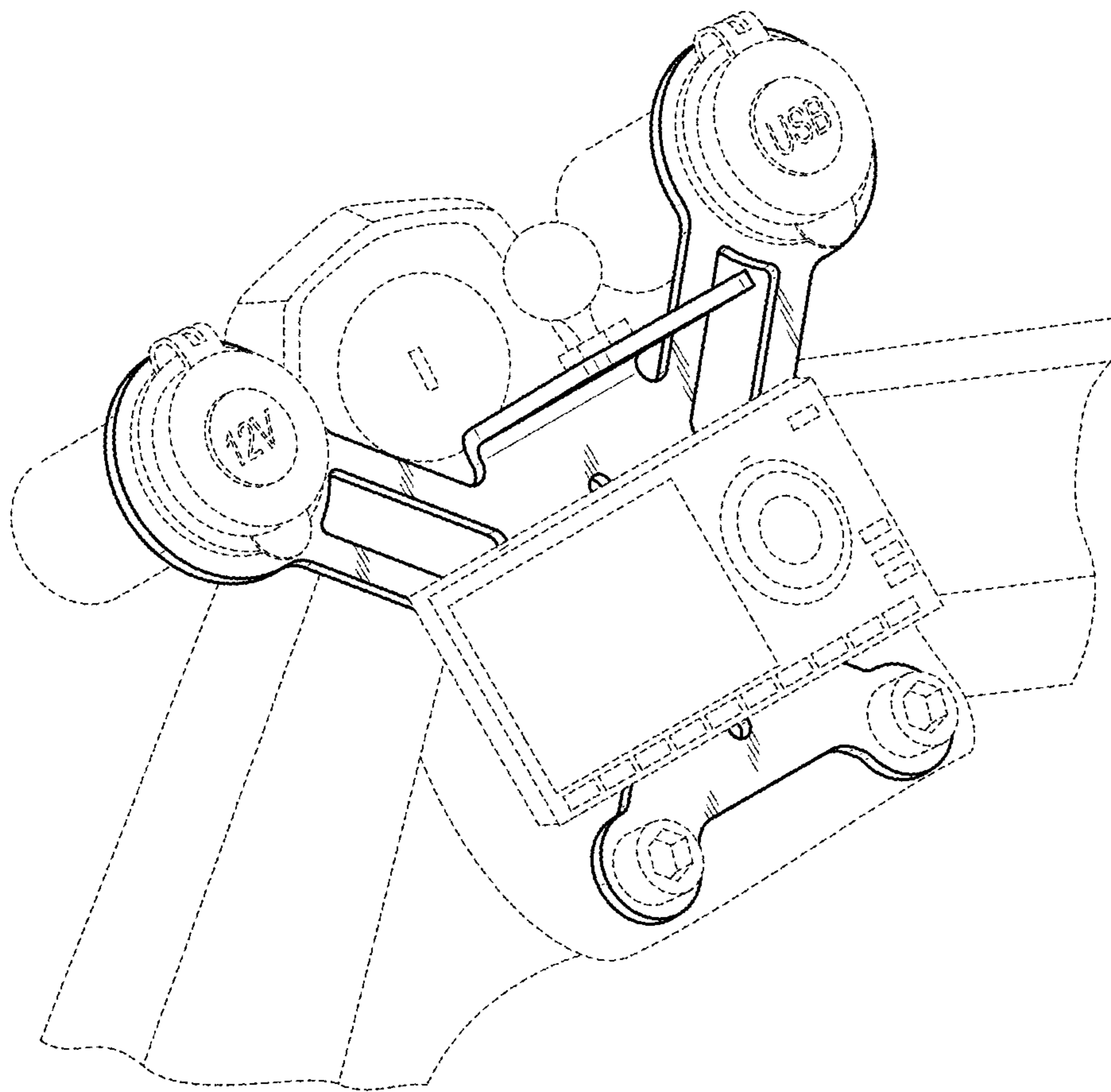
*FIG. 7*



*FIG. 8*



*FIG. 9*



*FIG. 10*