



US00D826010S

(12) **United States Design Patent**
de Vries et al.

(10) **Patent No.:** **US D826,010 S**

(45) **Date of Patent:** **** Aug. 21, 2018**

(54) **MULTI-TOOL FOR KITCHEN**

(71) Applicants: **Robert de Vries**, Rotterdam (NL);
Alexander Cornelis van Druten,
Berkel en Rodenrijs (NL)

(72) Inventors: **Robert de Vries**, Rotterdam (NL);
Alexander Cornelis van Druten,
Berkel en Rodenrijs (NL)

(73) Assignee: **Robert De Vries**, Rotterdam (NL)

(**) Term: **15 Years**

(21) Appl. No.: **29/581,561**

(22) Filed: **Oct. 20, 2016**

(51) **LOC (11) Cl.** **07-06**

(52) **U.S. Cl.**

USPC **D7/686**

(58) **Field of Classification Search**

USPC D7/683-687

CPC A21C 15/00; A47G 21/10; A47G 21/00;

A47G 21/0021; A47G 21/06; A47G

21/103; A47G 21/106; A47J 43/283; A47J

43/288

See application file for complete search history.

(56) **References Cited**

U.S. PATENT DOCUMENTS

2,810,957 A * 10/1957 Nelson A47G 21/02

30/324

D291,763 S * 9/1987 Dunn D7/687

D679,154 S * 4/2013 Sawicki D7/686
D712,709 S * 9/2014 Pau D7/686
2006/0157996 A1* 7/2006 McRorie, III A47G 21/10
294/16

* cited by examiner

Primary Examiner — Terry A Wallace

(57) **CLAIM**

The ornamental design for a multi-tool for kitchen, as shown and described.

DESCRIPTION

FIG. 1 is a top view of the multi-tool, open;
FIG. 2 is a right side perspective of the multi-tool, open;
FIG. 3 is a left side close up perspective of the multi-tool, open;
FIG. 4 is a bottom view of the multi-tool, open;
FIG. 5 is a top view of the multi-tool, closed;
FIG. 6 is a back view of the multi-tool, open;
FIG. 7 is a front side view of the multi-tool; closed; and,
FIG. 8 is a side view of the multi-tool.

Any broken line illustration in the photo is not part of the design sought to be patented.

1 Claim, 4 Drawing Sheets

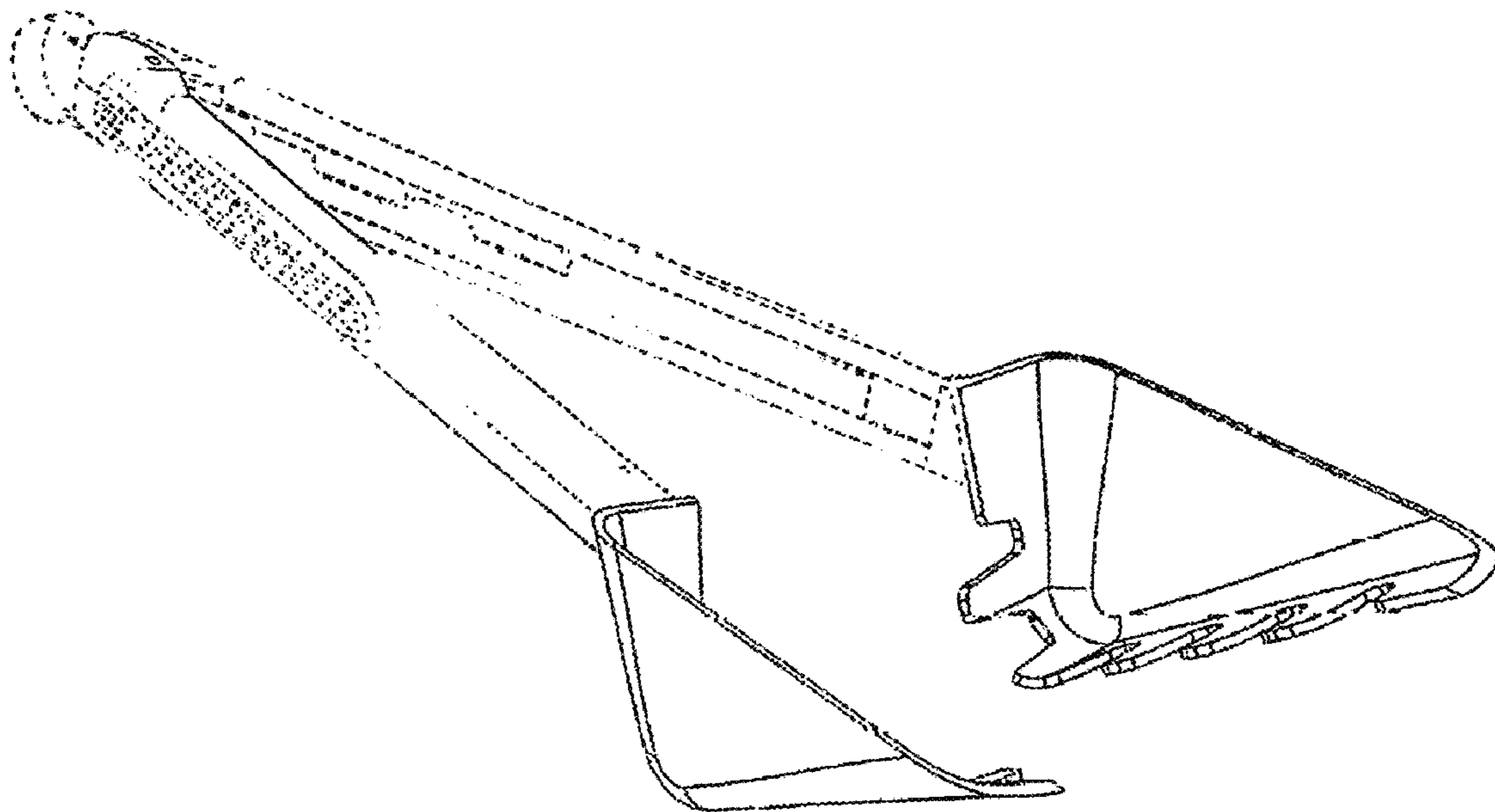

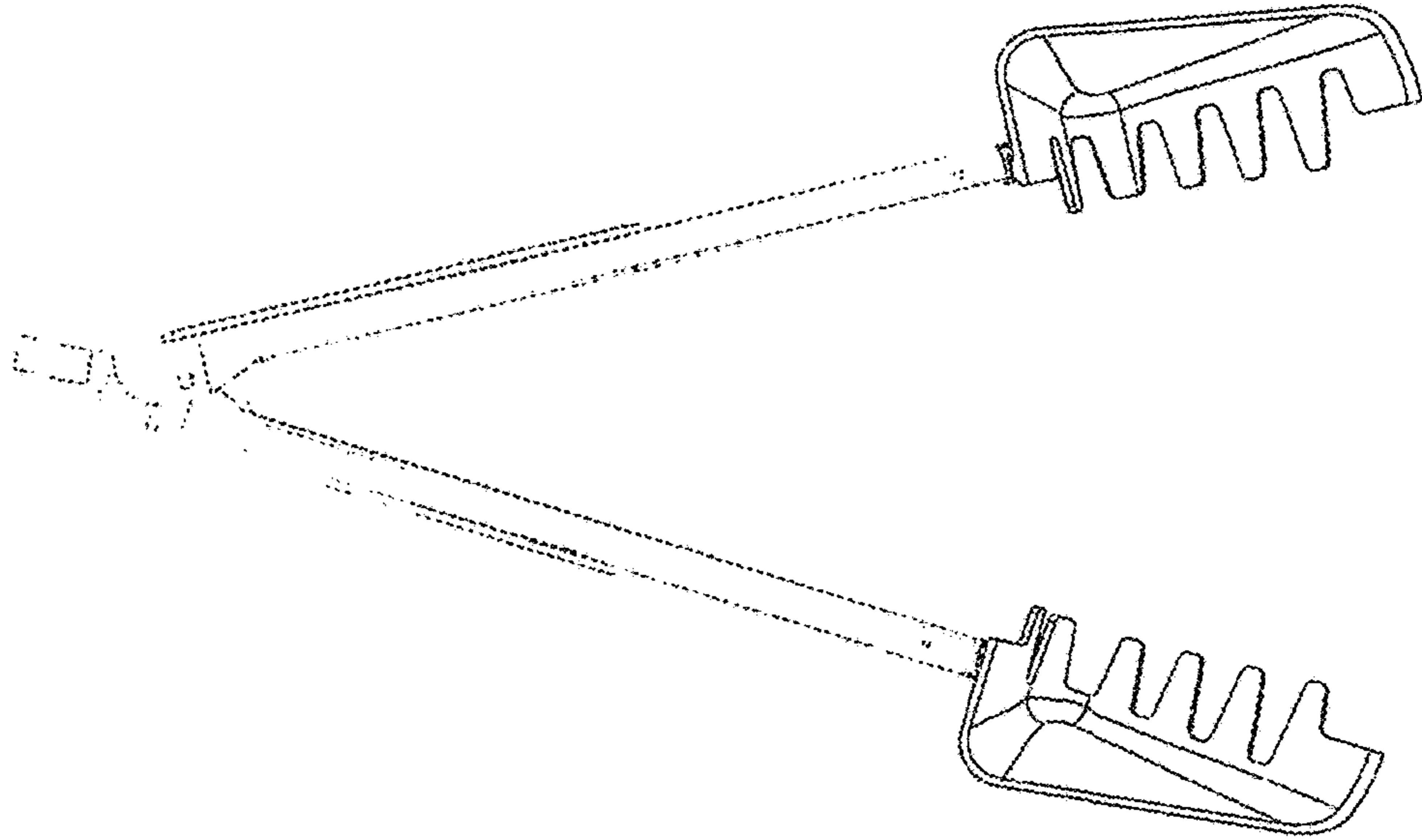

Fig. 1

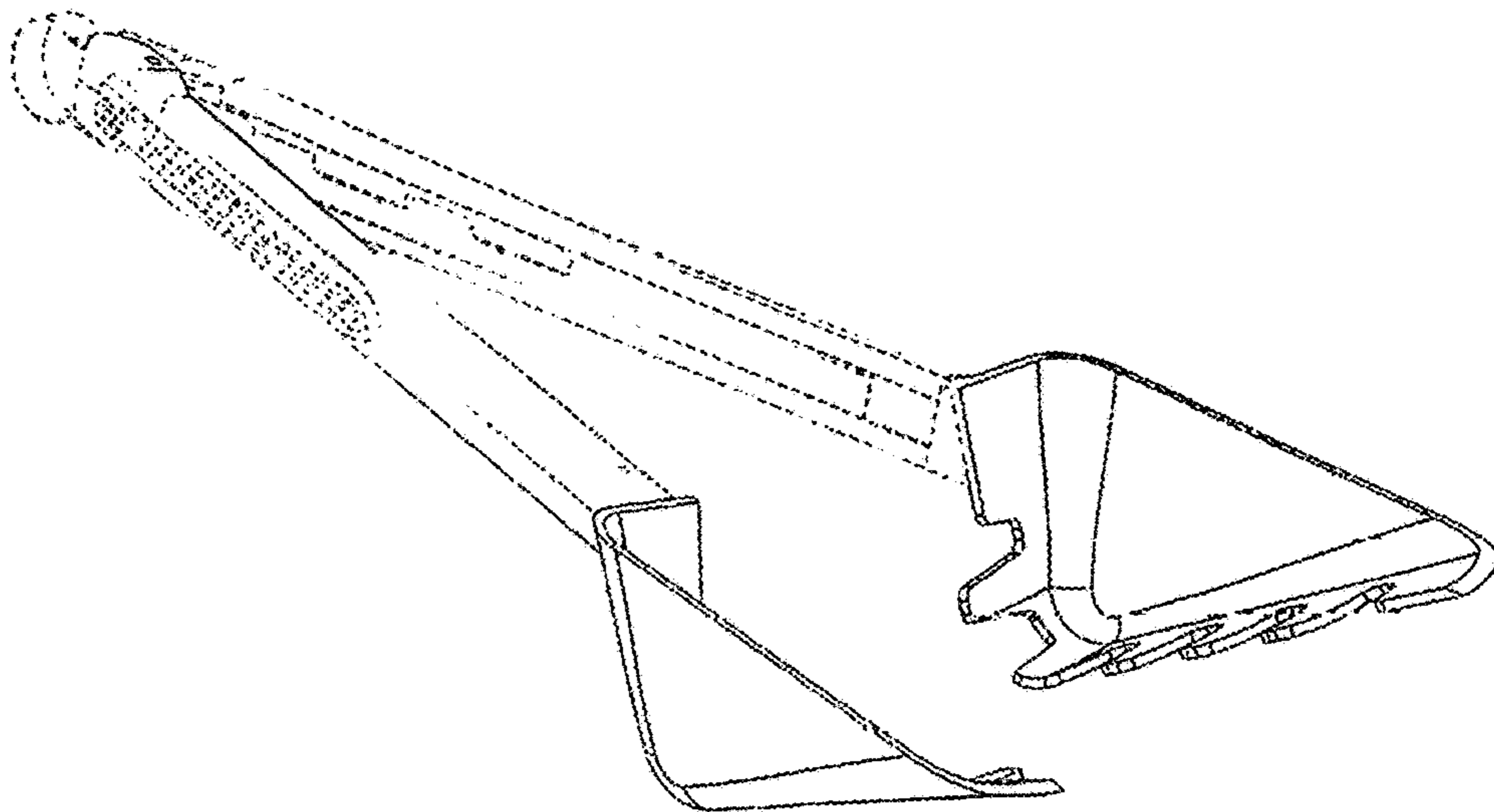

Fig. 2

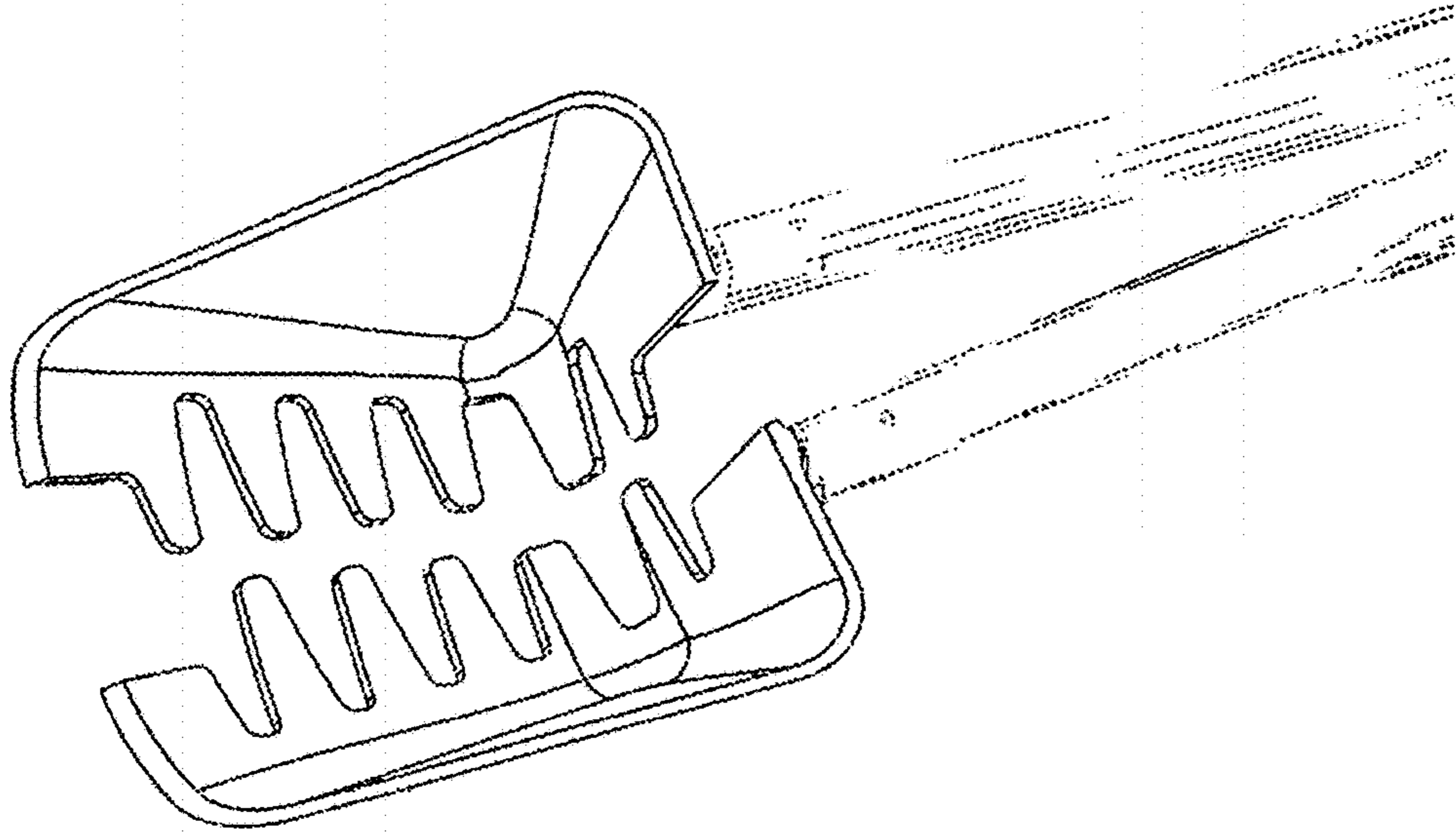

Fig. 3

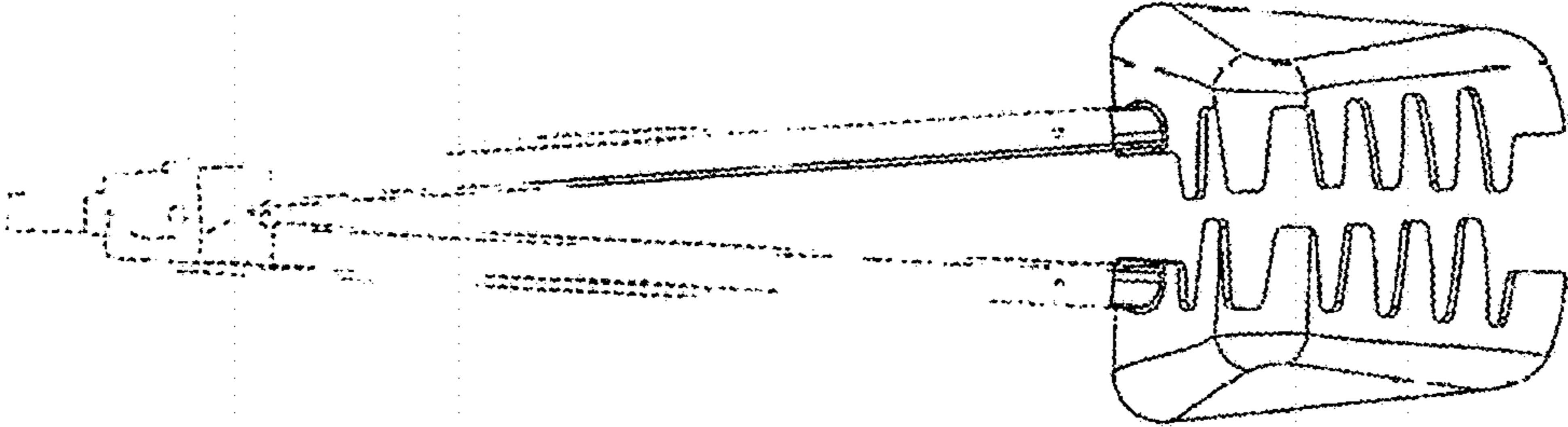

Fig. 4

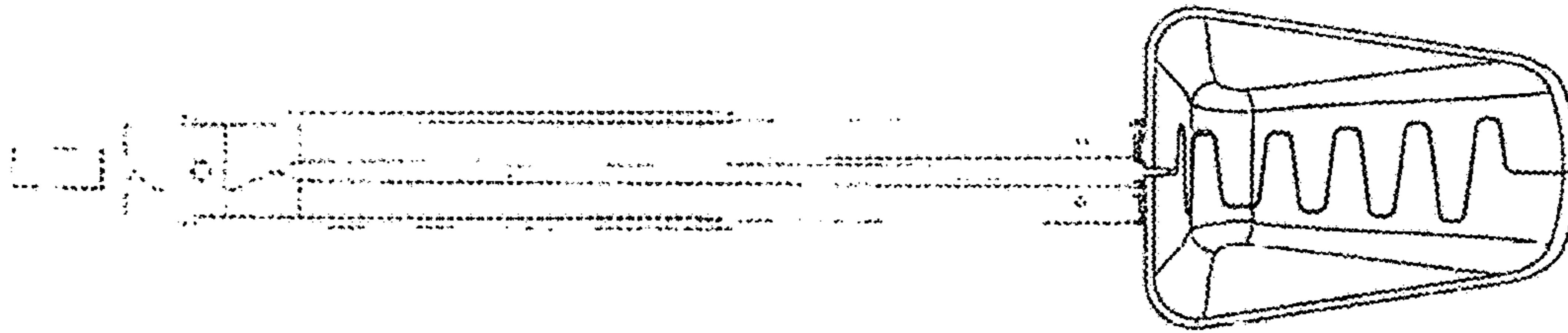

Fig. 5

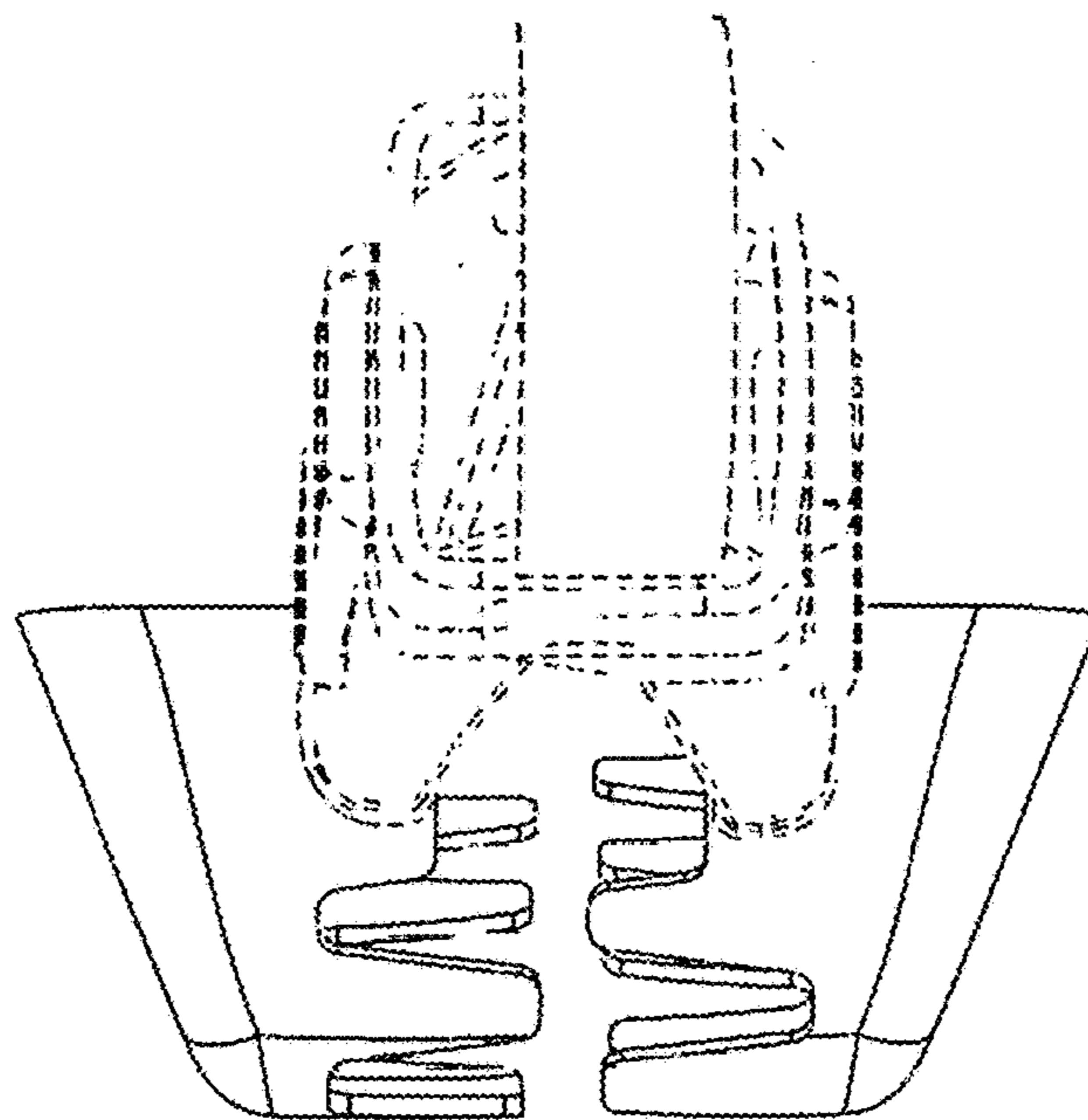

Fig. 6

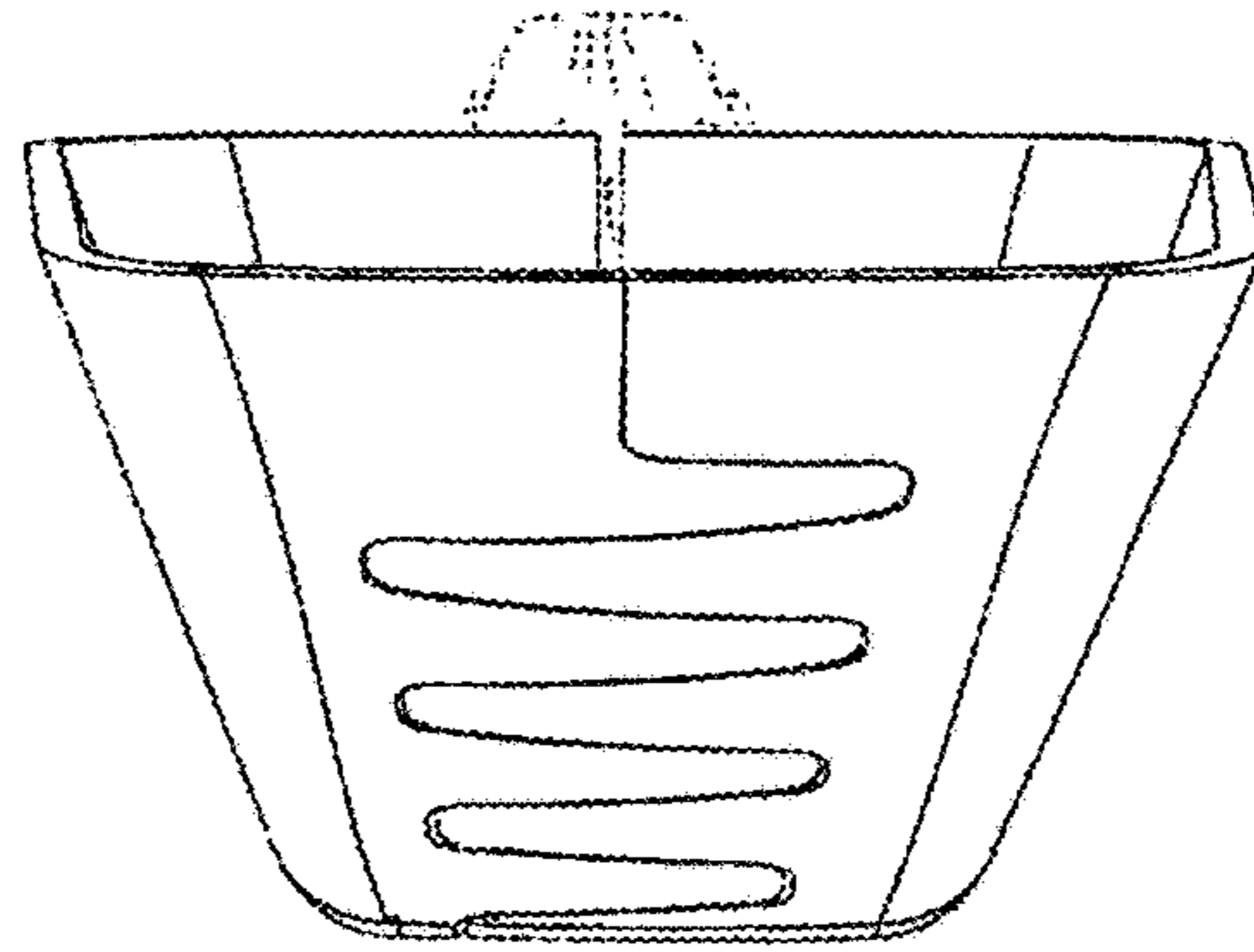

Fig. 7

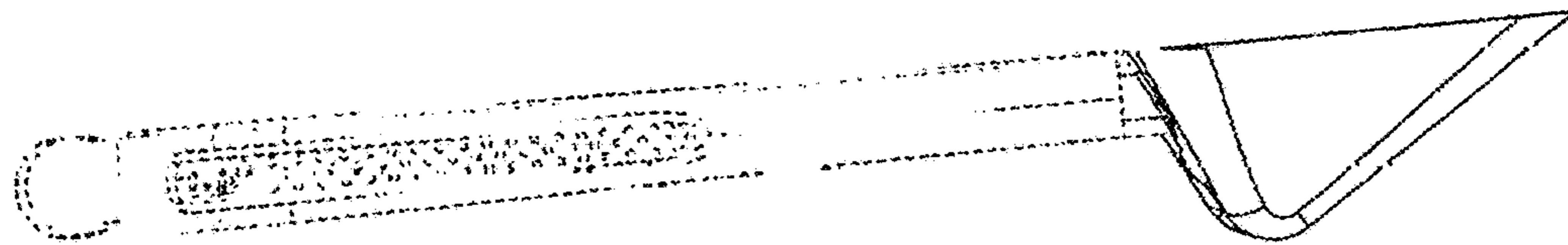

Fig. 8