



US00D825683S

(12) **United States Design Patent** (10) **Patent No.:** **US D825,683 S**
Liu (45) **Date of Patent:** **** Aug. 14, 2018**

(54) **REMOTE CONTROL BUMPER CAR**
 (71) Applicant: **MerchSource, LLC**, Irvine, CA (US)
 (72) Inventor: **Jeffrey Liu**, Ngau Tau Kok (HK)
 (73) Assignee: **MerchSource, LLC**, Irvine, CA (US)
 (**) Term: **15 Years**
 (21) Appl. No.: **29/612,093**
 (22) Filed: **Jul. 28, 2017**
 (51) **LOC (11) Cl.** **21-01**
 (52) **U.S. Cl.**
 USPC **D21/533; D21/833**
 (58) **Field of Classification Search**
 USPC D21/433, 533, 548, 550, 551, 833
 CPC A63H 17/26; A63H 17/262; A63H 17/264;
 A63H 17/266; A63H 17/36; A63H 17/38;
 A63H 29/00; A63H 29/22; A63H 29/24;
 A63H 30/04
 See application file for complete search history.

(56) **References Cited**
 U.S. PATENT DOCUMENTS
 D250,550 S * 12/1978 Reverchon D12/5
 4,217,975 A * 8/1980 Barth B60L 5/06
 191/13
 D267,185 S * 12/1982 Reverchon D21/833
 5,100,173 A * 3/1992 Kudler A63G 25/00
 180/271
 D371,975 S * 7/1996 Dukstra D10/12
 D377,492 S * 1/1997 Dijkstra D14/168
 2007/0007779 A1 * 1/2007 Thomson A63H 33/3033
 293/107

2007/0209851 A1* 9/2007 Sweringen A63G 25/00
 180/65.51
 2010/0051357 A1* 3/2010 Kessler A63G 25/00
 180/2.1
 2010/0147609 A1* 6/2010 Gorgas A63G 25/00
 180/65.51

* cited by examiner
Primary Examiner — Robin V Webster
Assistant Examiner — Keith J Wilson
 (74) *Attorney, Agent, or Firm* — Avyno Law P.C.

(57) **CLAIM**
 I claim the ornamental design for a remote control bumper car, as shown and described.

DESCRIPTION
 FIG. 1 is a front perspective view of a remote control bumper car.
 FIG. 2 is a side view of the right side of the remote control bumper car of FIG. 1.
 FIG. 3 is a side view of the left side of the remote control bumper car of FIG. 1.
 FIG. 4 is a front view of the remote control bumper car of FIG. 1.
 FIG. 5 is a rear view of the remote control bumper car of FIG. 1.
 FIG. 6 is a top view of the remote control bumper car of FIG. 1; and,
 FIG. 7 is a bottom view of the remote control bumper car of FIG. 1.
 The broken line represents environment only and forms no part of the claimed design.

1 Claim, 6 Drawing Sheets

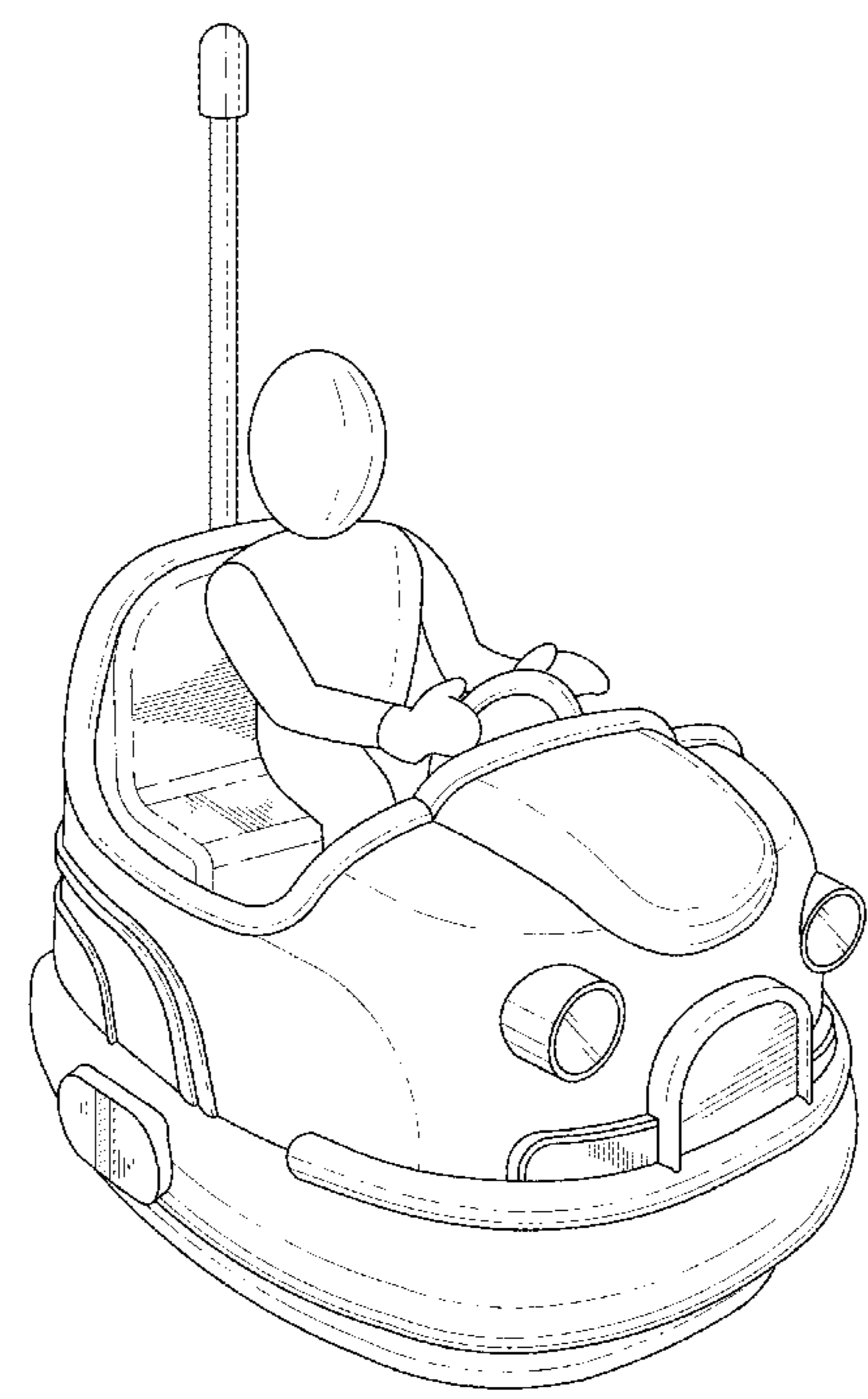

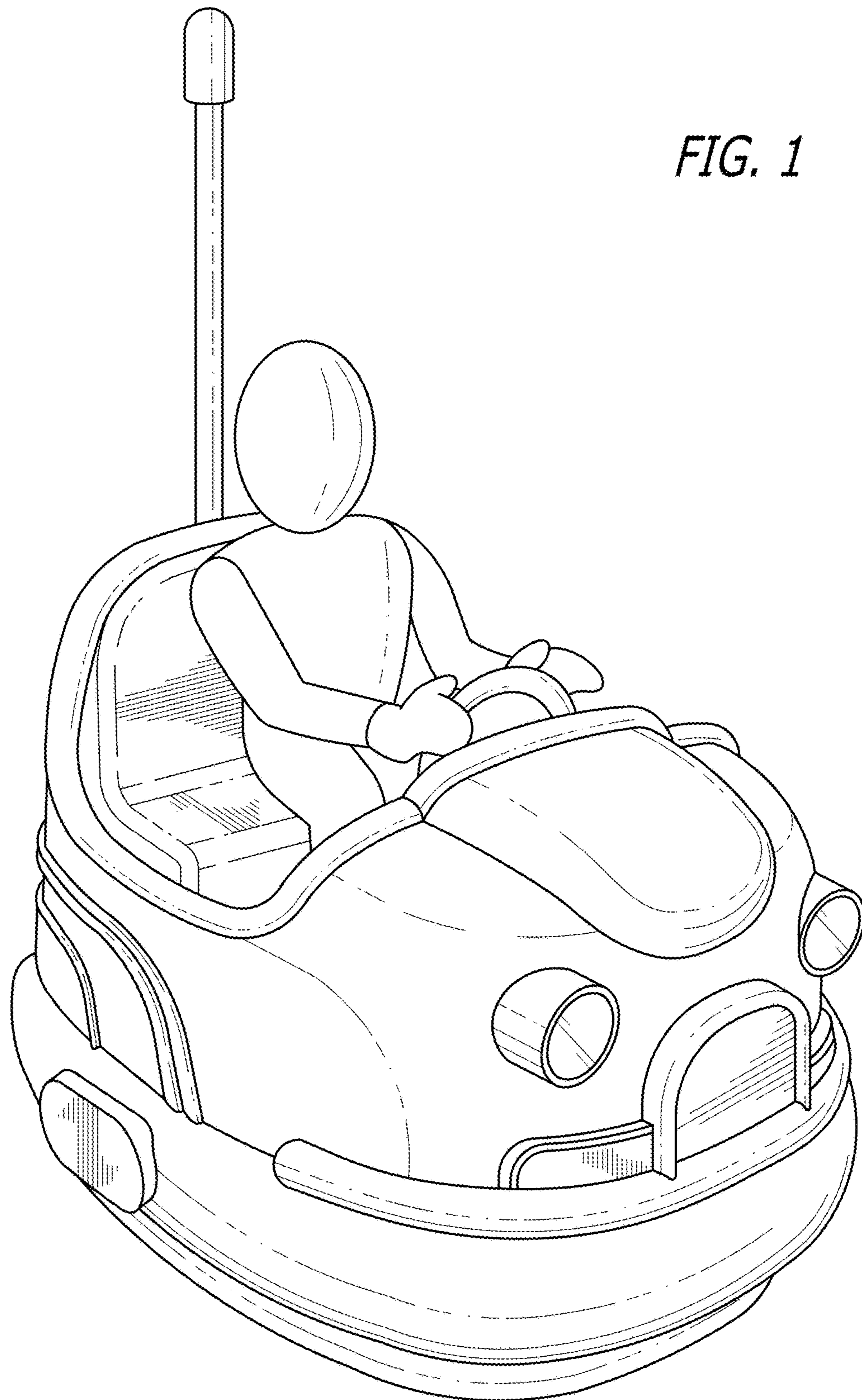

FIG. 1

FIG. 2

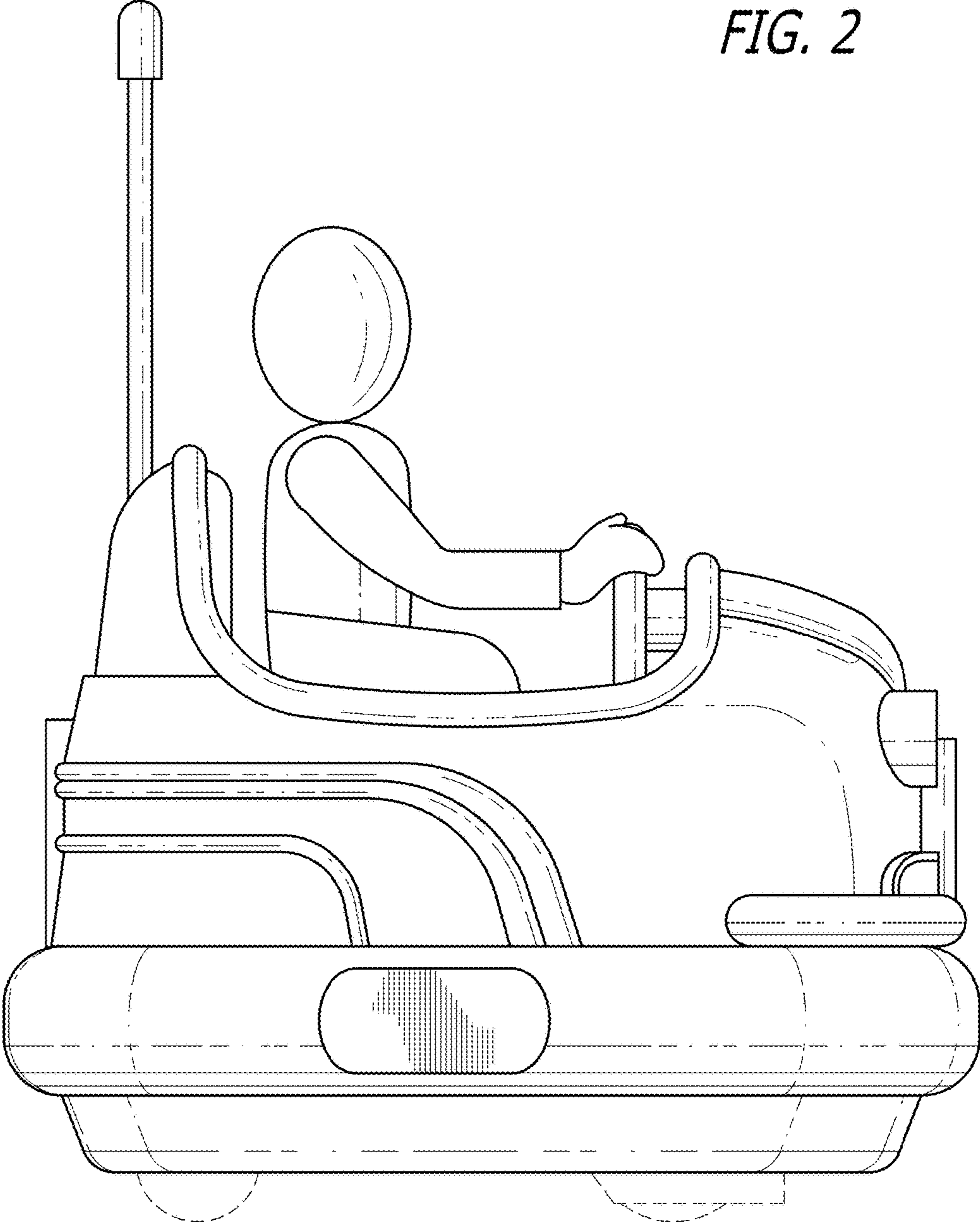

FIG. 3

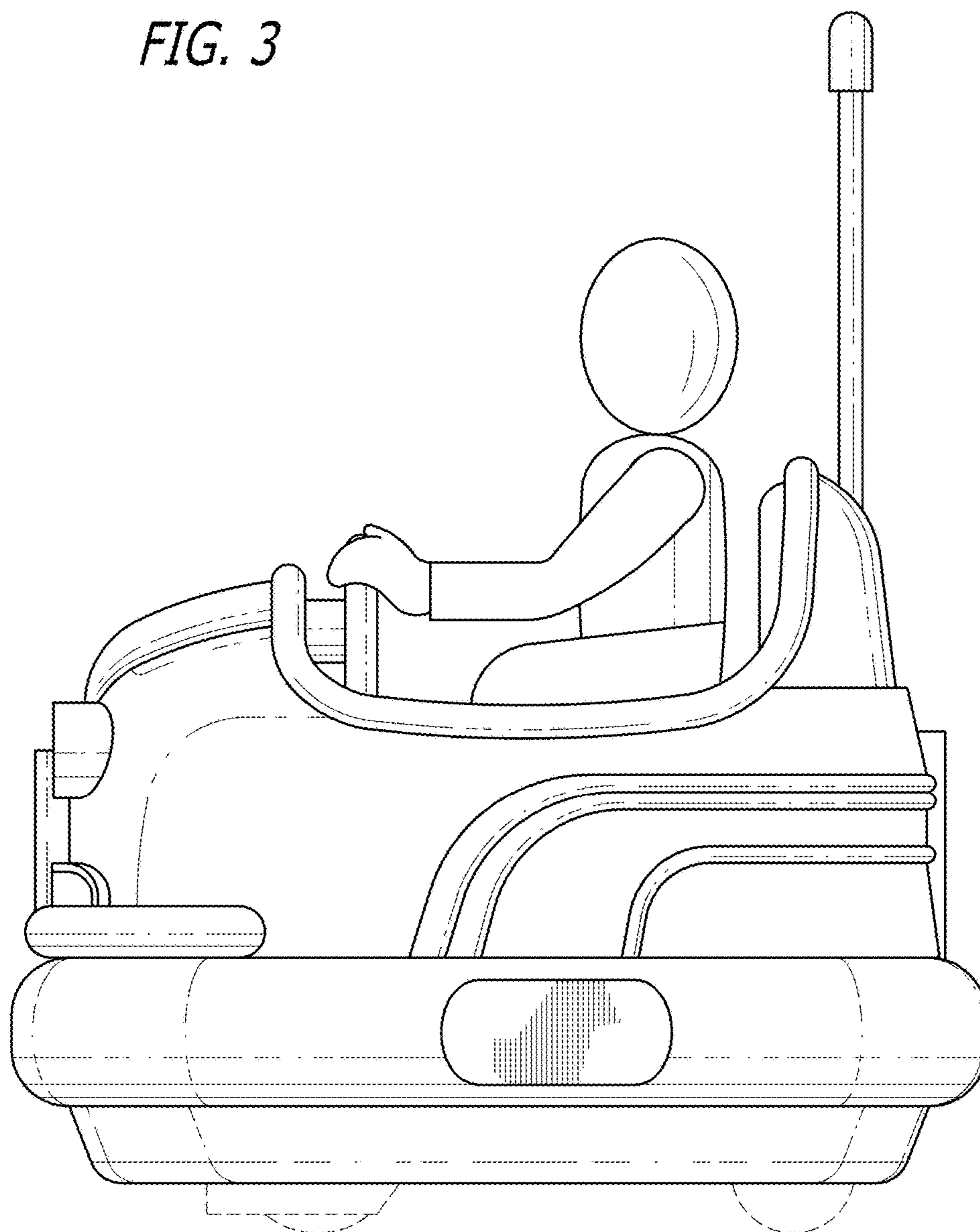

FIG. 4

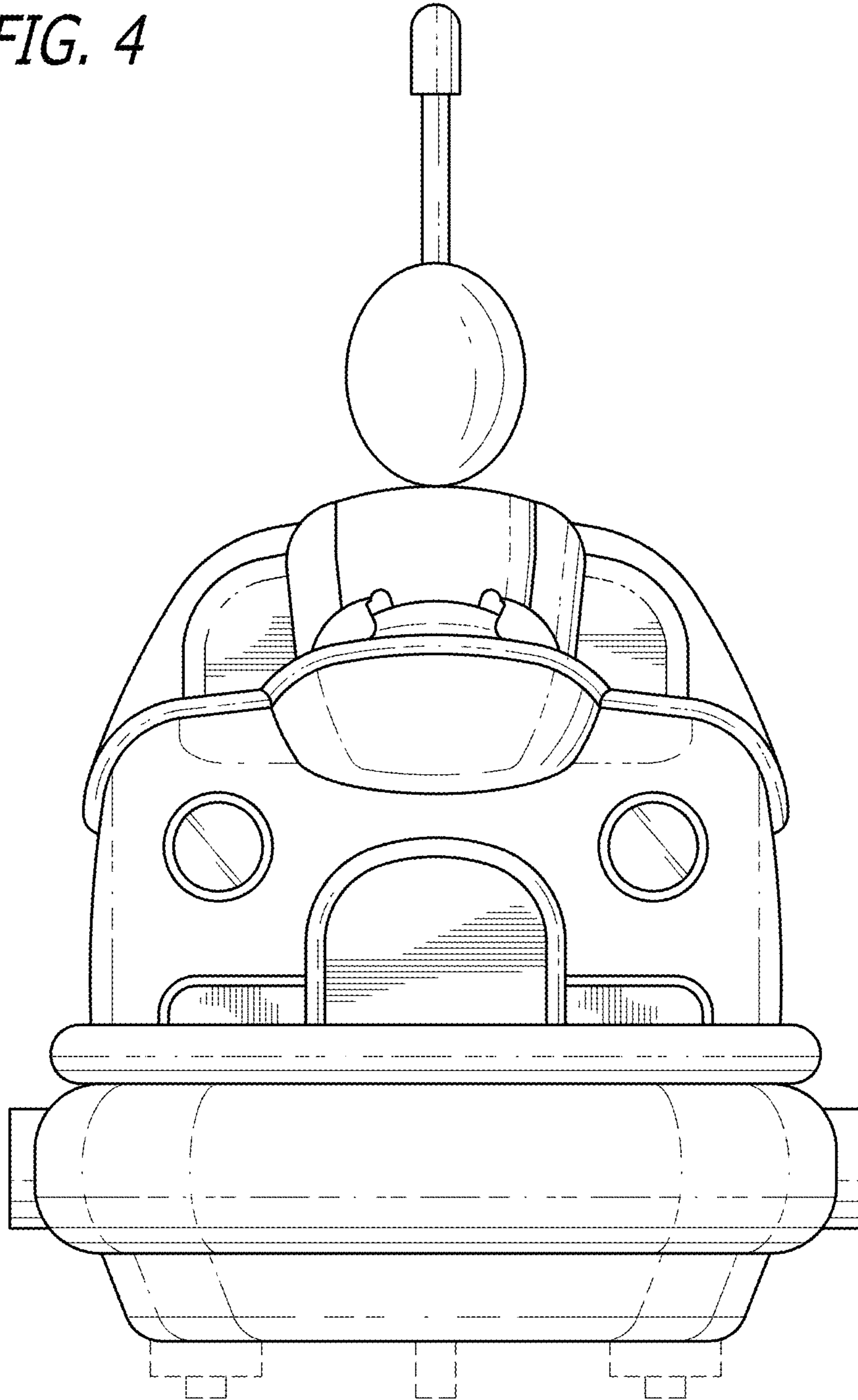

FIG. 5

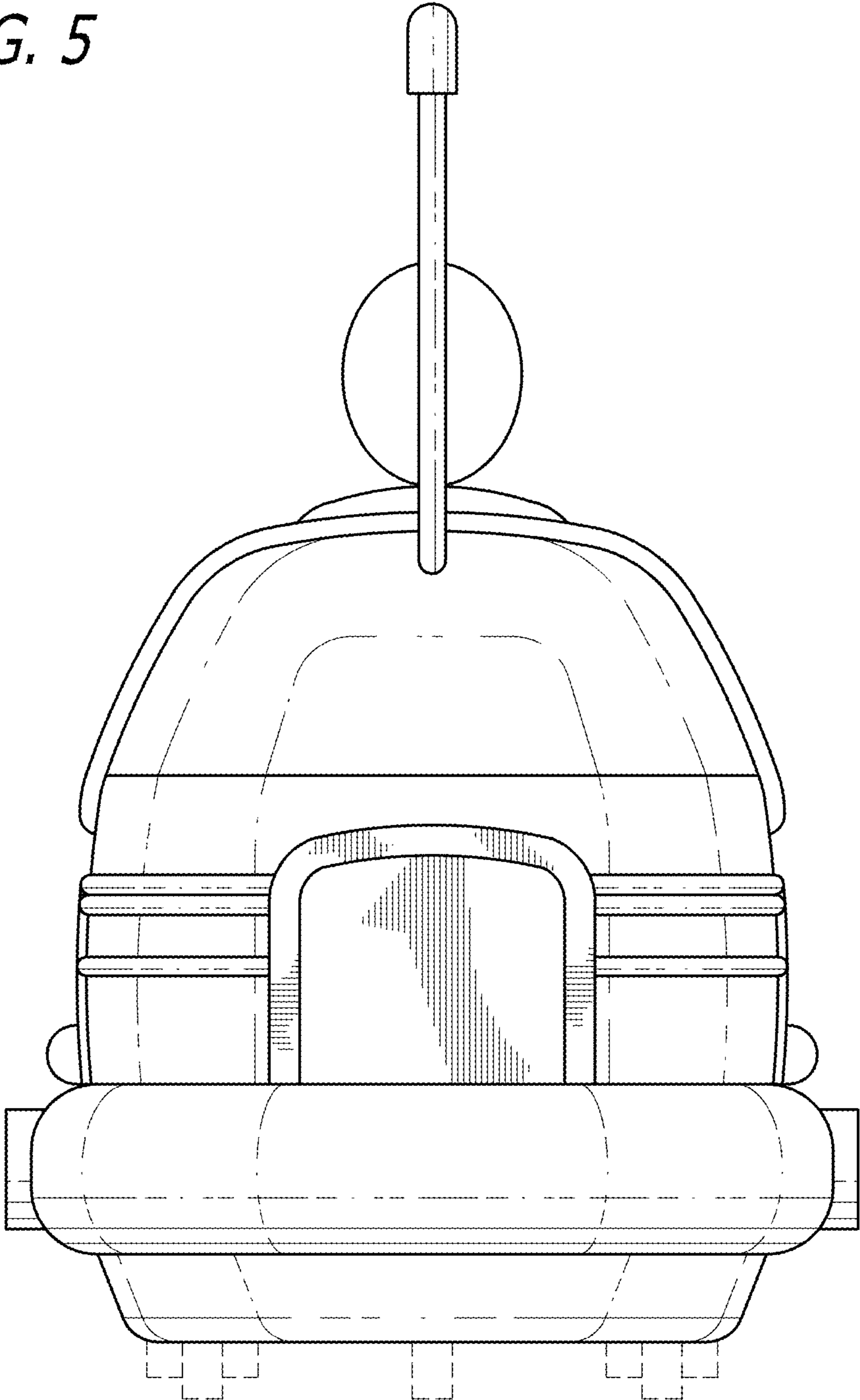

FIG. 6

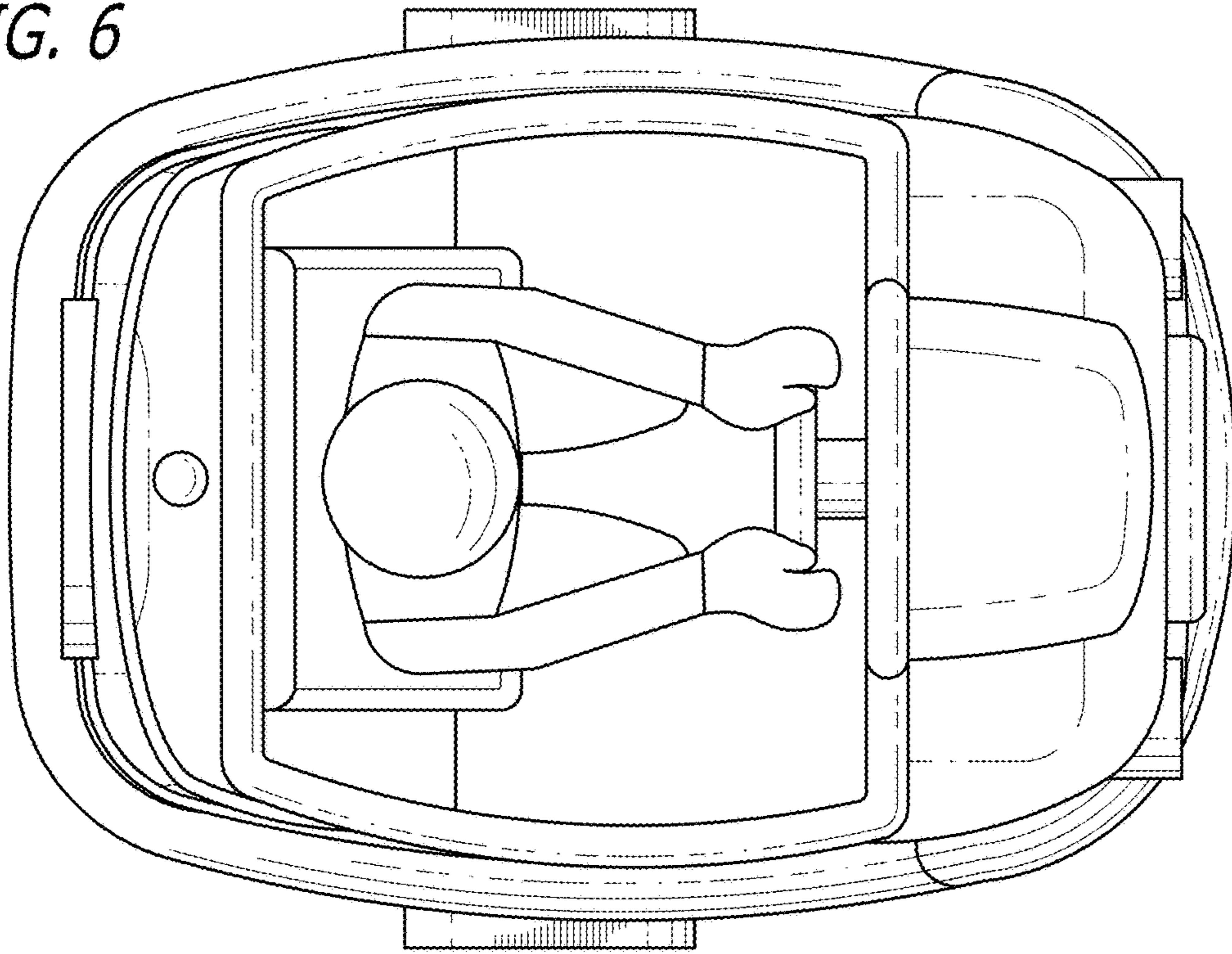

FIG. 7

