



US00D825667S

(12) **United States Design Patent** (10) **Patent No.:** **US D825,667 S**
Snyder (45) **Date of Patent:** **** Aug. 14, 2018**

(54) **EDUCATIONAL SET OF CHILDREN'S DICE BLOCKS**

(71) Applicant: **Viggi Corporation**, Fairport, NY (US)

(72) Inventor: **Christalyn Snyder**, East Rochester, NY (US)

(73) Assignee: **Viggi Corp.**, Rochester, NY (US)

(**) Term: **15 Years**

(21) Appl. No.: **29/544,100**

(22) Filed: **Oct. 30, 2015**

(51) **LOC (11) Cl.** **21-03**

(52) **U.S. Cl.**
USPC **D21/373**

(58) **Field of Classification Search**
USPC D21/373, 604, 367, 351, 386, 372, 385,
D21/498, 714, 479, 707, 708; 273/161,
(Continued)

(56) **References Cited**

U.S. PATENT DOCUMENTS

- 1,593,907 A * 7/1926 Madan A63F 9/0413
273/146
- D212,631 S * 11/1968 Spiring 273/146
(Continued)

Primary Examiner — Philip S Hyder

Assistant Examiner — Ryan Harvey

(74) *Attorney, Agent, or Firm* — Dinsmore & Shohl LLP

(57) **CLAIM**

The ornamental design for educational set of children's dice blocks, as shown and described.

DESCRIPTION

FIG. 1 is a top view of a first block of the educational set of children's dice blocks;

FIG. 2 is a front view of the block of FIG. 1, the back being identical to the front;

FIG. 3 is a bottom view of the block of FIG. 1;

FIG. 4 is a right side view of the block of FIG. 1, the left side being a mirror image thereof;

FIG. 5 is a perspective view from above, in front of, and to the right of the block of FIG. 1;

FIG. 6 is a perspective view from below, behind, and to the left of the block of FIG. 1;

FIG. 7 is a top view of a second block of the educational set of children's dice blocks;

FIG. 8 is a front view of the block of FIG. 7, the back being identical to the front;

FIG. 9 is a bottom view of the block of FIG. 7;

FIG. 10 is a right side view of the block of FIG. 7, the left side being a mirror image thereof;

FIG. 11 is a perspective view from above, in front of, and to the right of the block of FIG. 7;

FIG. 12 is a perspective view from below, behind, and to the left of the block of FIG. 7;

FIG. 13 is a top view of a third block of the educational set of children's dice blocks;

FIG. 14 is a front view of the block of FIG. 13, the back being identical to the front;

FIG. 15 is a bottom view of the block of FIG. 13;

FIG. 16 is a right side view of the block of FIG. 13, the left side being a mirror image thereof;

FIG. 17 is a perspective view from above, in front of, and to the right of the block of FIG. 13;

FIG. 18 is a perspective view from below, behind, and to the left of the block of FIG. 13;

FIG. 19 is a top view of a fourth block of the educational set of children's dice blocks;

FIG. 20 is a front view of the block of FIG. 19, the back being identical to the front;

FIG. 21 is a bottom view of the block of FIG. 19;

FIG. 22 is a right side view of the block of FIG. 19, the left side being a mirror image thereof;

FIG. 23 is a perspective view from above, in front of, and to the right of the block of FIG. 19;

FIG. 24 is a perspective view from below, behind, and to the left of the block of FIG. 19;

(Continued)

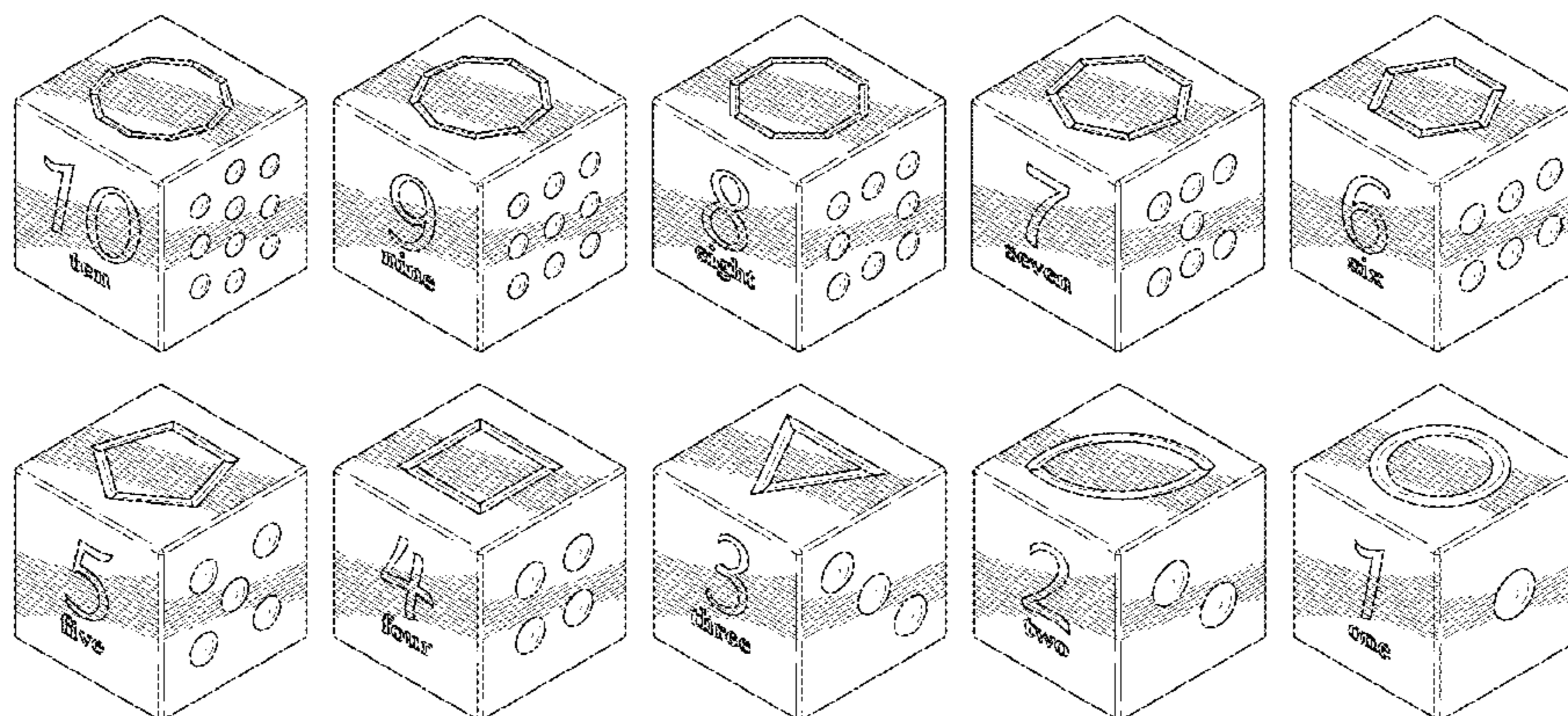

FIG. 25 is a top view of a fifth block of the educational set of children's dice blocks;
 FIG. 26 is a front view of the block of FIG. 25, the back being identical to the front;
 FIG. 27 is a bottom view of the block of FIG. 25;
 FIG. 28 is a right side view of the block of FIG. 25, the left side being a mirror image thereof;
 FIG. 29 is a perspective view from above, in front of, and to the right of the block of FIG. 25;
 FIG. 30 is a perspective view from below, behind, and to the left of the block of FIG. 25;
 FIG. 31 is a top view of a sixth block of the educational set of children's dice blocks;
 FIG. 32 is a front view of the block of FIG. 31, the back being identical to the front;
 FIG. 33 is a bottom view of the block of FIG. 31;
 FIG. 34 is a right side view of the block of FIG. 31, the left side being a mirror image thereof;
 FIG. 35 is a perspective view from above, in front of, and to the right of the block of FIG. 31;
 FIG. 36 is a perspective view from below, behind, and to the left of the block of FIG. 31;
 FIG. 37 is a top view of a seventh block of the educational set of children's dice blocks;
 FIG. 38 is a front view of the block of FIG. 37, the back being identical to the front;
 FIG. 39 is a bottom view of the block of FIG. 37;
 FIG. 40 is a right side view of the block of FIG. 37, the left side being a mirror image thereof;
 FIG. 41 is a perspective view from above, in front of, and to the right of the block of FIG. 37;
 FIG. 42 is a perspective view from below, behind, and to the left of the block of FIG. 37;
 FIG. 43 is a top view of an eighth block of the educational set of children's dice blocks;
 FIG. 44 is a front view of the block of FIG. 43, the back being identical to the front;
 FIG. 45 is a bottom view of the block of FIG. 43;
 FIG. 46 is a right side view of the block of FIG. 43, the left side being a mirror image thereof;
 FIG. 47 is a perspective view from above, in front of, and to the right of the block of FIG. 43;
 FIG. 48 is a perspective view from below, behind, and to the left of the block of FIG. 43;
 FIG. 49 is a top view of a ninth block of the educational set of children's dice blocks;
 FIG. 50 is a front view of the block of FIG. 49, the back being identical to the front;
 FIG. 51 is a bottom view of the block of FIG. 49;
 FIG. 52 is a right side view of the block of FIG. 49, the left side being a mirror image thereof;
 FIG. 53 is a perspective view from above, in front of, and to the right of the block of FIG. 49;
 FIG. 54 is a perspective view from below, behind, and to the left of the block of FIG. 49;

FIG. 55 is a top view of a tenth block of the educational set of children's dice blocks;
 FIG. 56 is a front view of the block of FIG. 55, the back being identical to the front;
 FIG. 57 is a bottom view of the block of FIG. 55;
 FIG. 58 is a right side view of the block of FIG. 55, the left side being a mirror image thereof;
 FIG. 59 is a perspective view from above, in front of, and to the right of the block of FIG. 55;
 FIG. 60 is a perspective view from below, behind, and to the left of the block of FIG. 55; and,
 FIG. 61 is a set of the educational children's dice blocks as illustrated from a perspective view from above, in front of, and of the right of the respective first through tenth blocks of FIGS. 1, 7, 13, 19, 25, 31, 37, 43, 49, 55.

1 Claim, 21 Drawing Sheets

(58) **Field of Classification Search**

USPC 273/146, 274, 292, 138.1, 268; D11/90, D11/142; D19/59, 96, 62, 25, 181, 909; D8/382, 397; D99/99; D25/13; D26/130; 52/DIG. 10; D20/99; D30/160; 446/256; 473/569; 434/172; D24/155, 101, 106; D15/126, 90; D9/431, 680; D1/127; D22/116; D14/226; D7/515, 510, 511, 523
 CPC A63F 9/04; A63F 3/00157; A63F 9/0413; A63F 9/0415; A63F 9/0468; A63F 2009/0484; G07F 17/32
 See application file for complete search history.

(56) **References Cited**

U.S. PATENT DOCUMENTS

D254,558	S *	3/1980	Rice	D21/373
D262,725	S *	1/1982	Rice	D21/373
D262,726	S *	1/1982	Rice	D21/373
D268,851	S *	5/1983	Mack	D21/373
D269,983	S *	8/1983	Lapadura	D21/373
D304,208	S *	10/1989	Loftus	D21/373
D313,250	S *	12/1990	Pacitti	D21/373
5,405,145	A *	4/1995	Jones	A63F 9/0402 273/146
5,641,166	A *	6/1997	Reisel	A63F 3/00176 273/261
D383,799	S *	9/1997	Beaumier	D21/373
D441,806	S *	5/2001	Bensimon	D21/373
D517,612	S *	3/2006	Bowling	D21/373
D553,694	S *	10/2007	Oharenko	D21/373
D561,842	S *	2/2008	Bowling	D21/373
D579,057	S *	10/2008	Arms	D21/373
D696,354	S *	12/2013	Barry	D21/373
D720,018	S *	12/2014	Murphy	D21/351

* cited by examiner

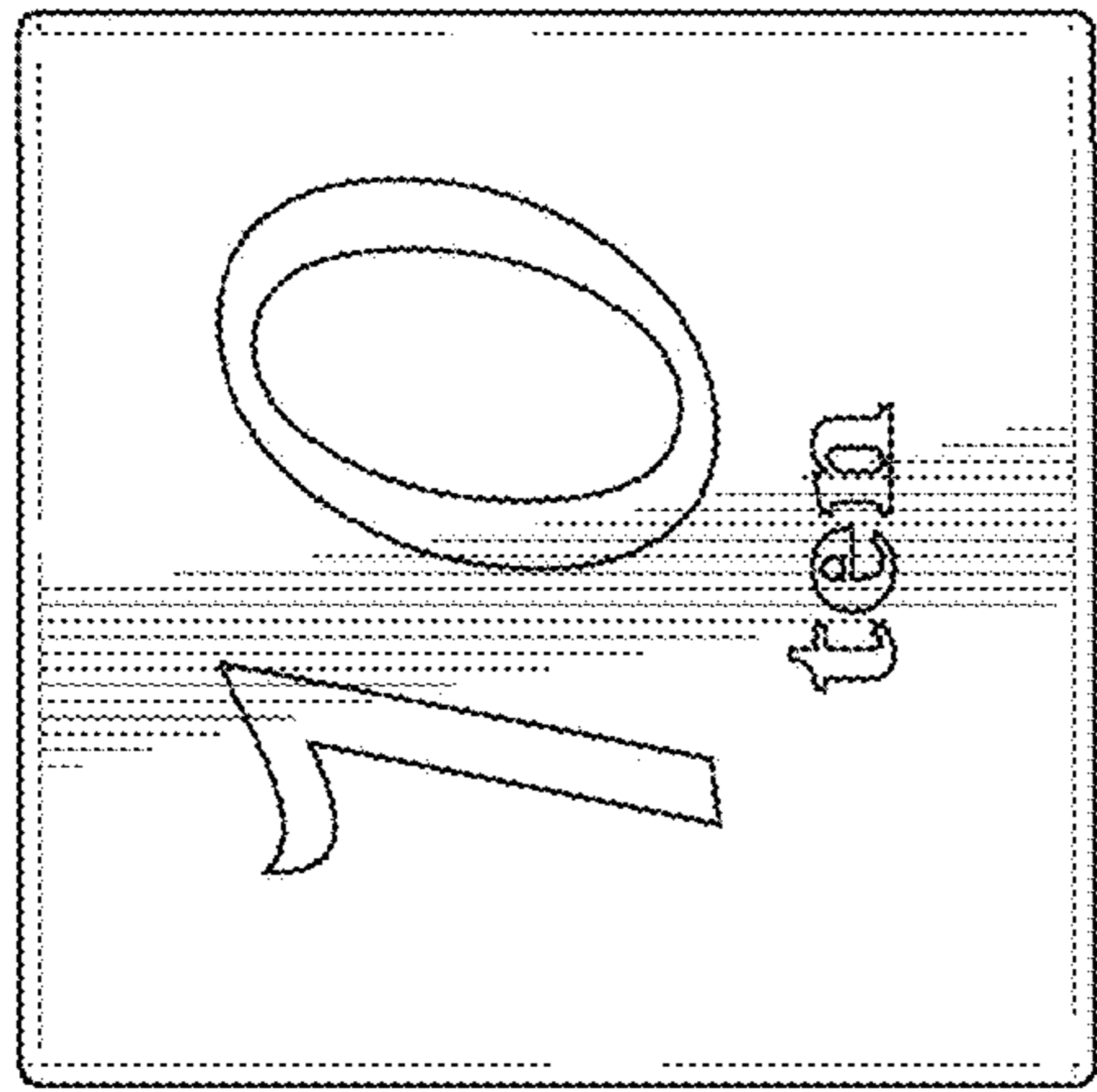

FIG. 2

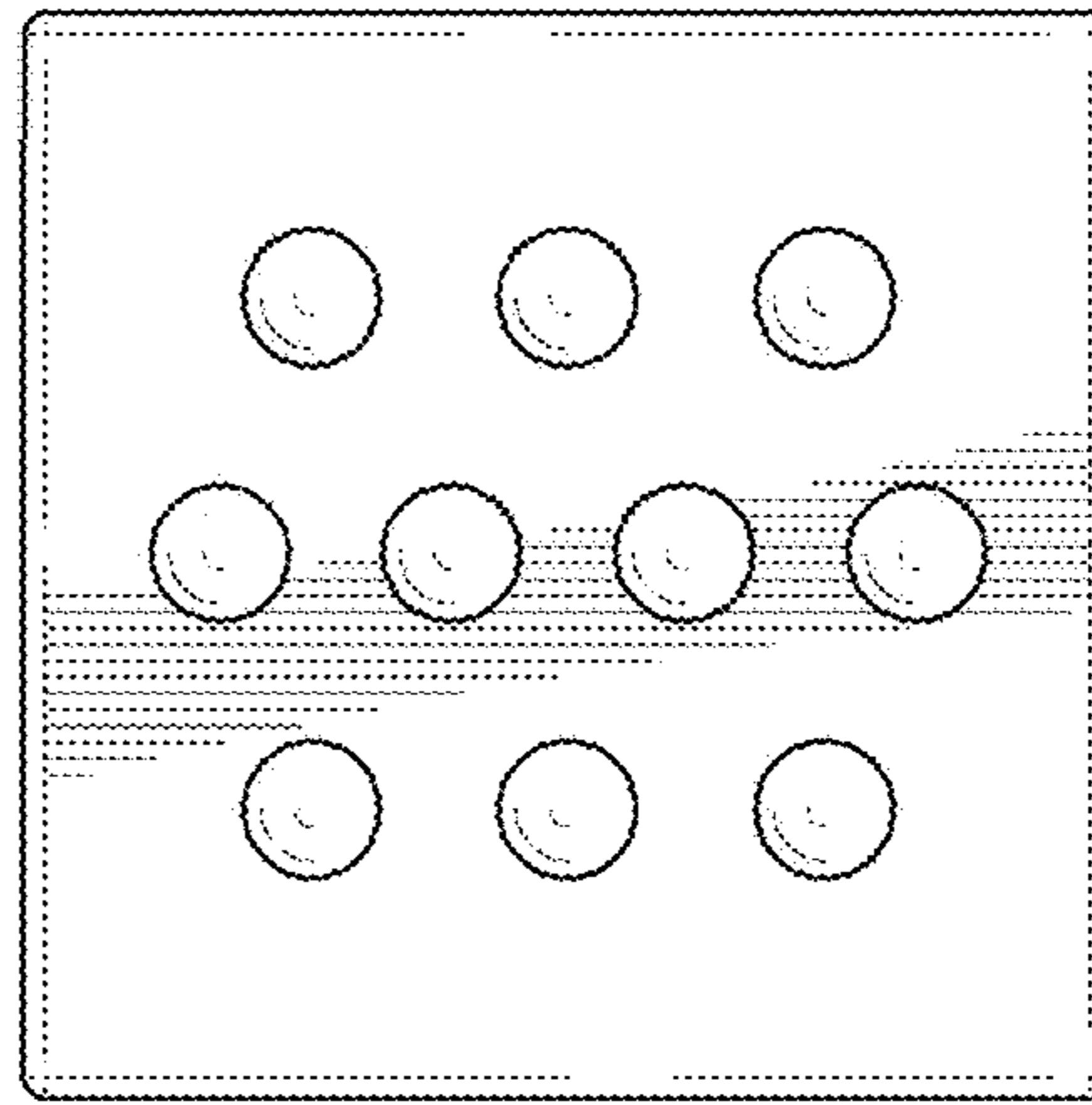

FIG. 4

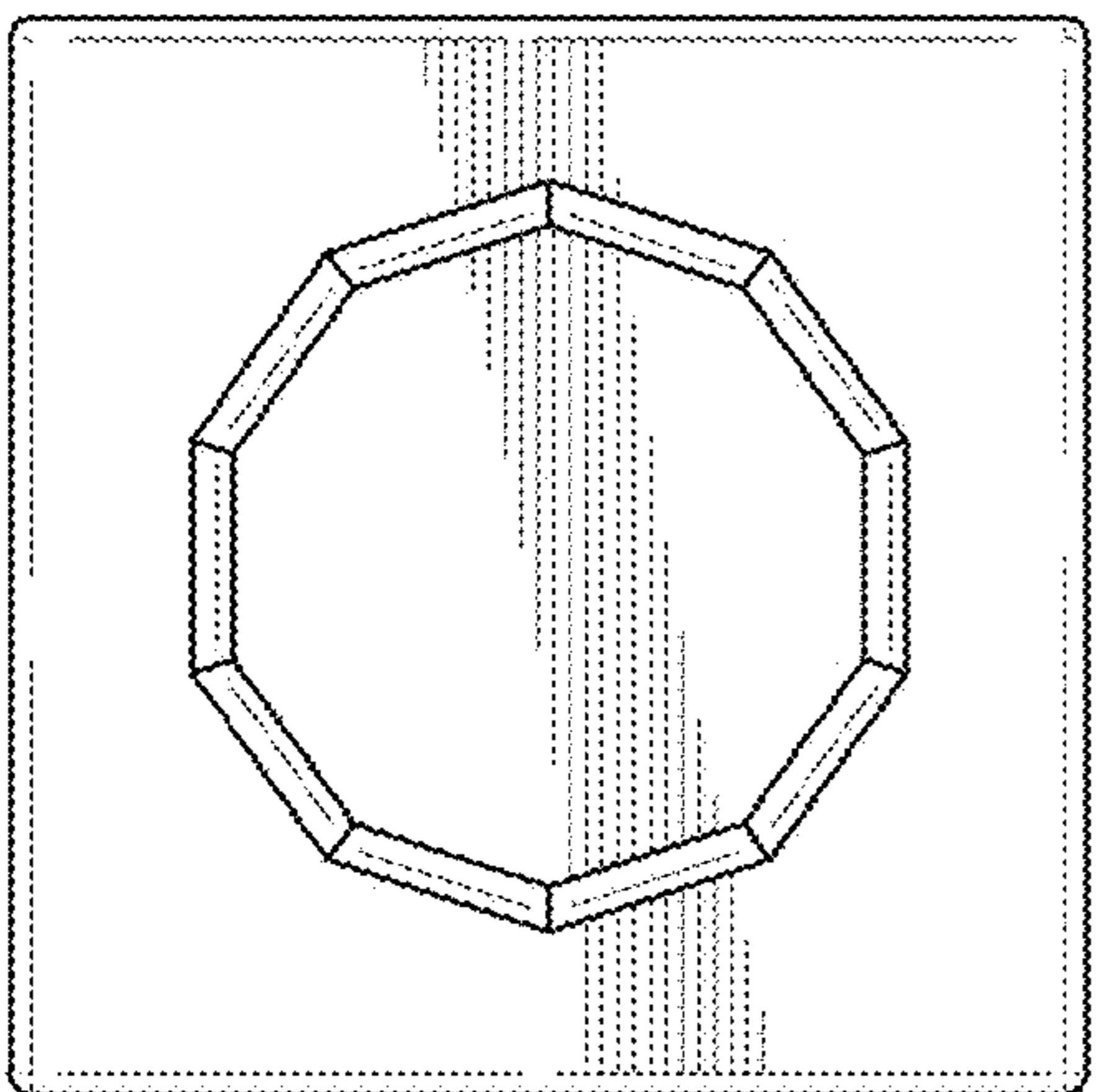

FIG. 1

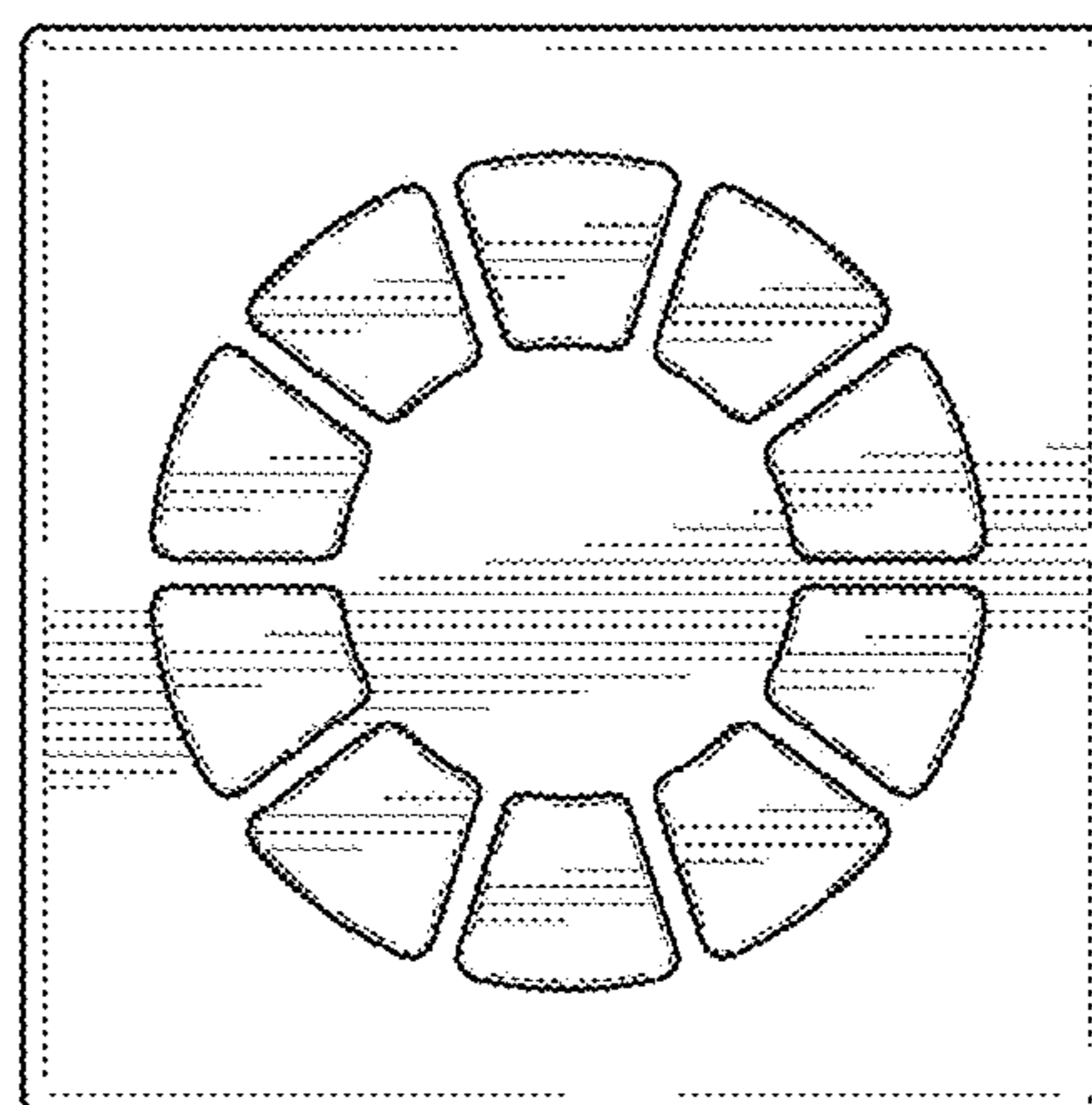

FIG. 3

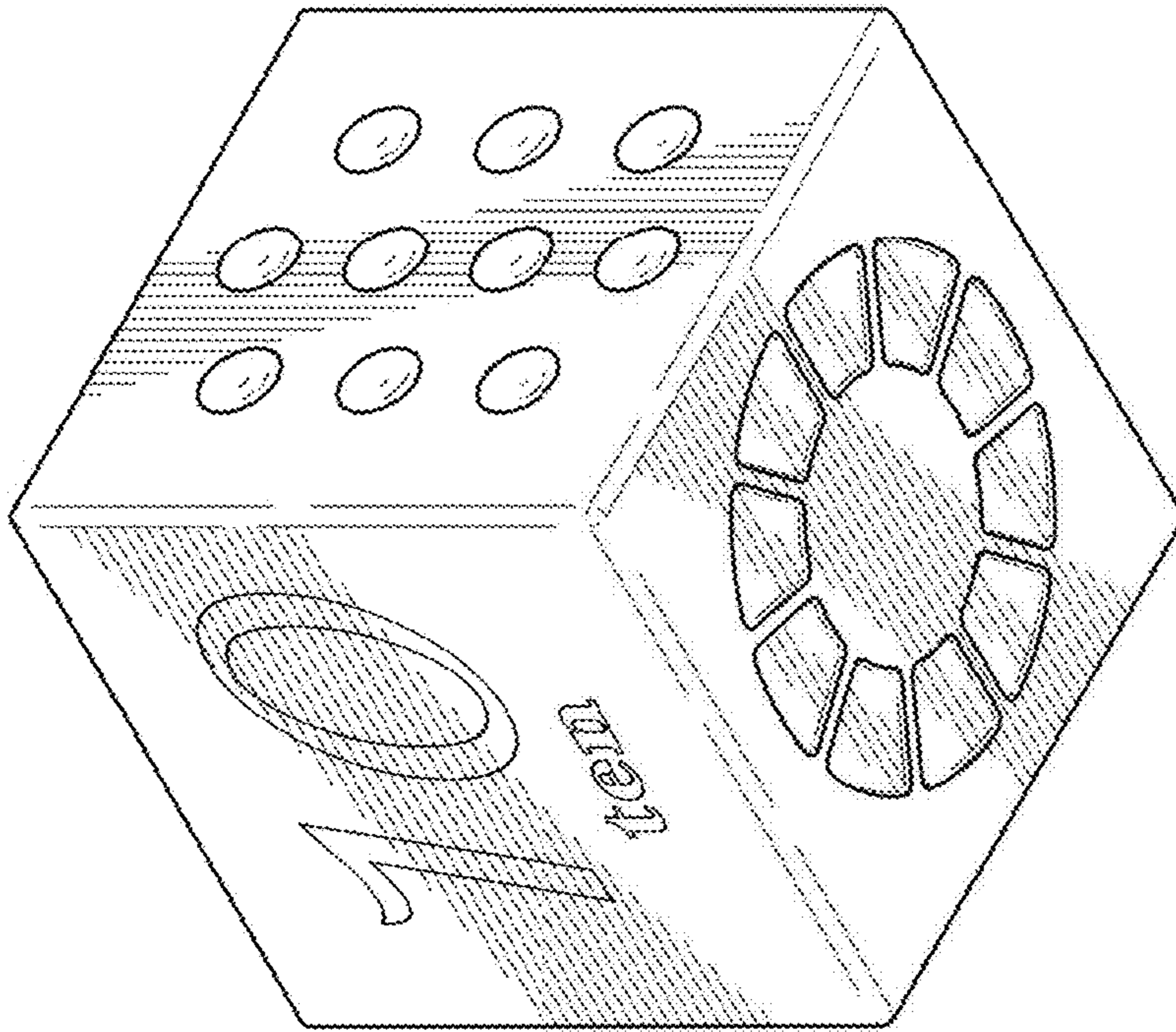

FIG. 5

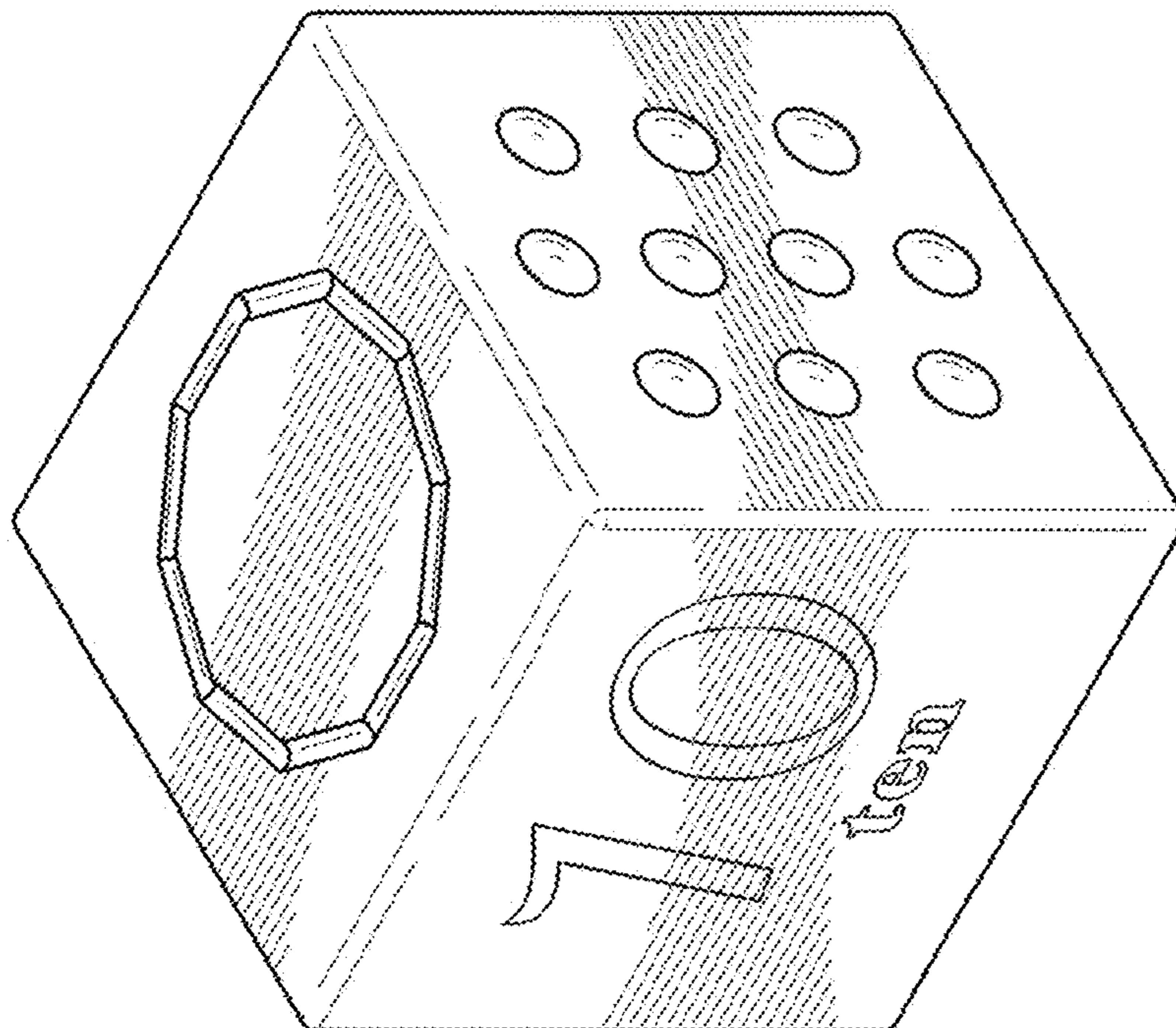

FIG. 6

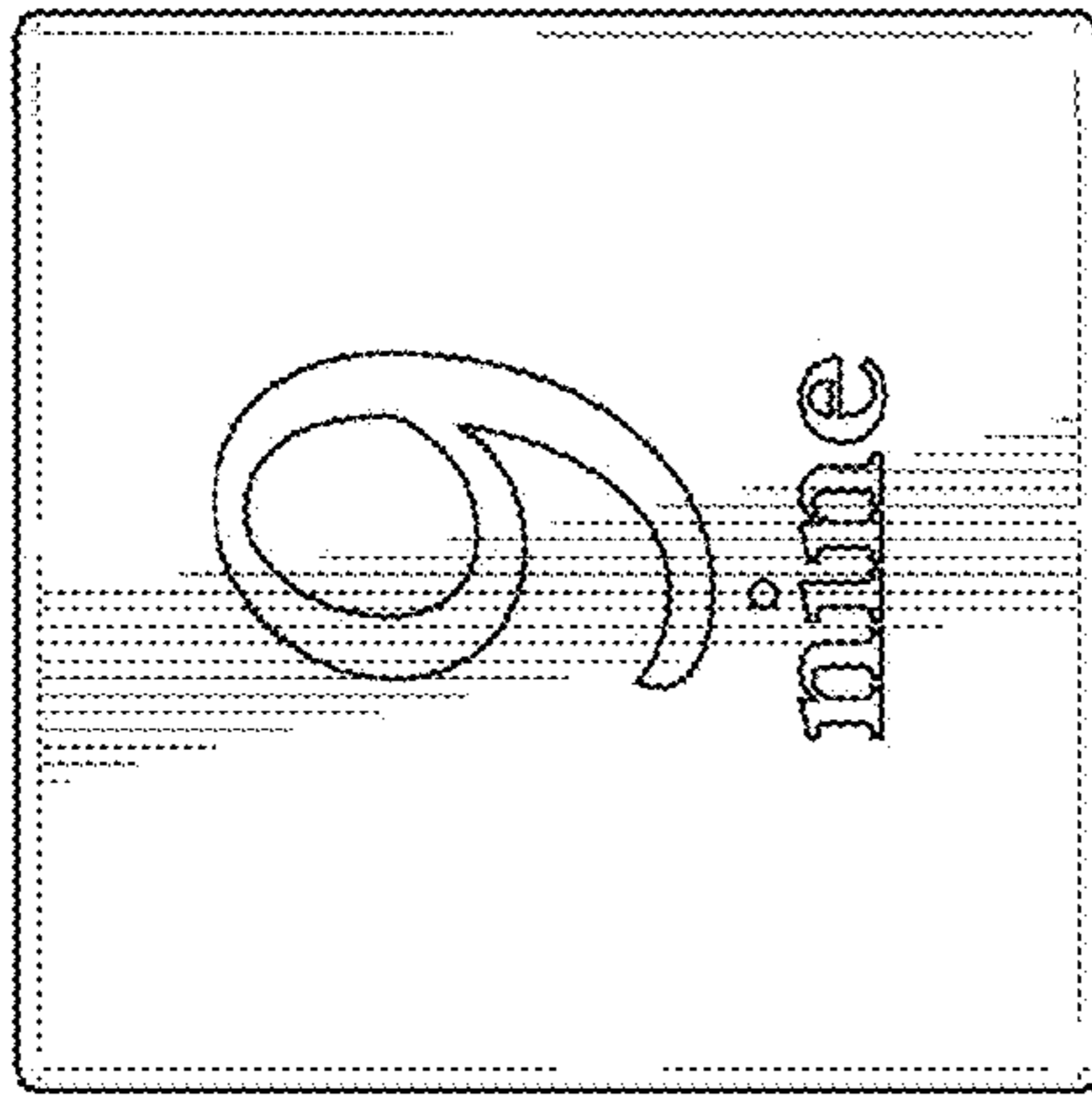

FIG. 8

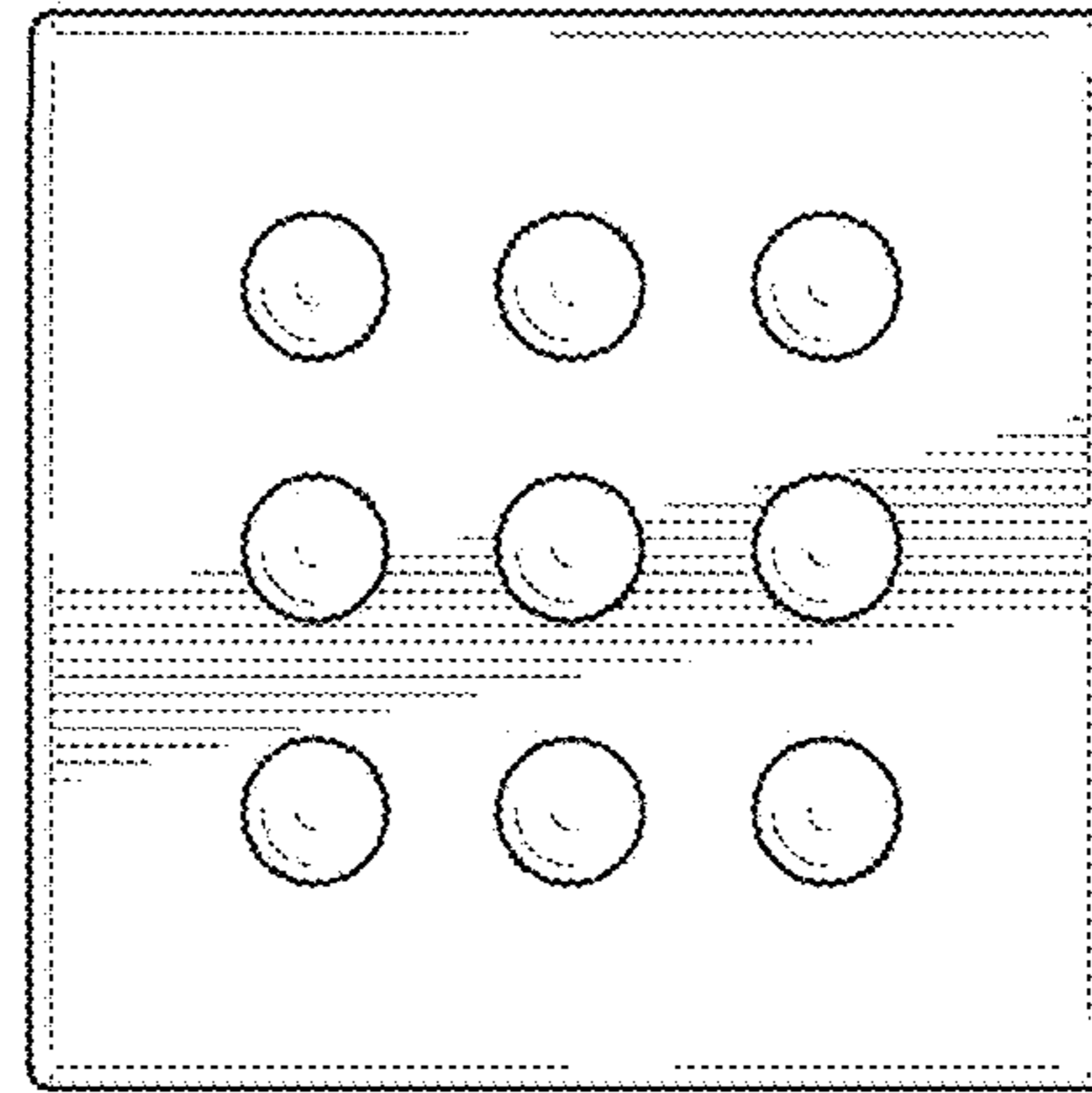

FIG. 10

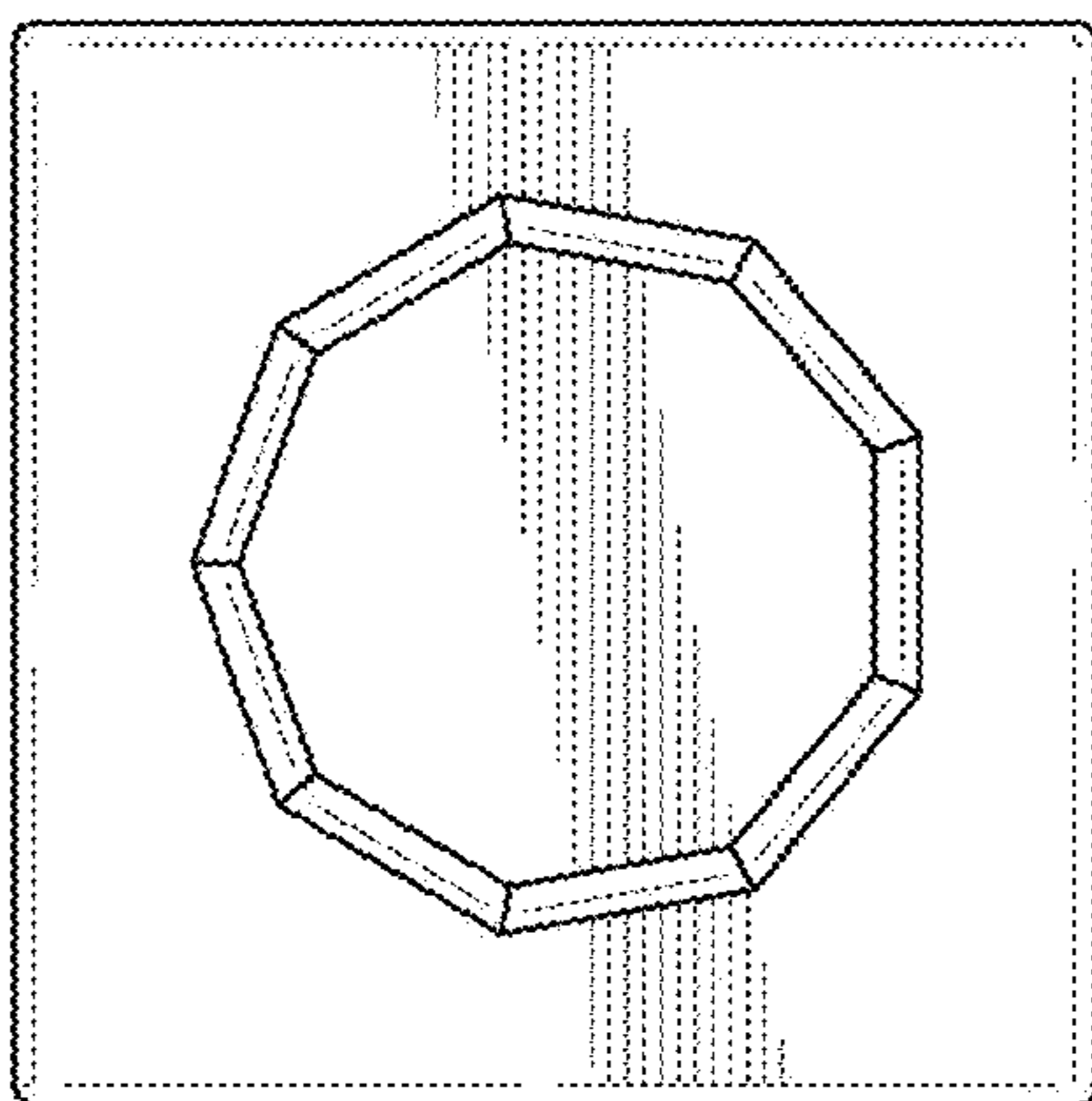

FIG. 7

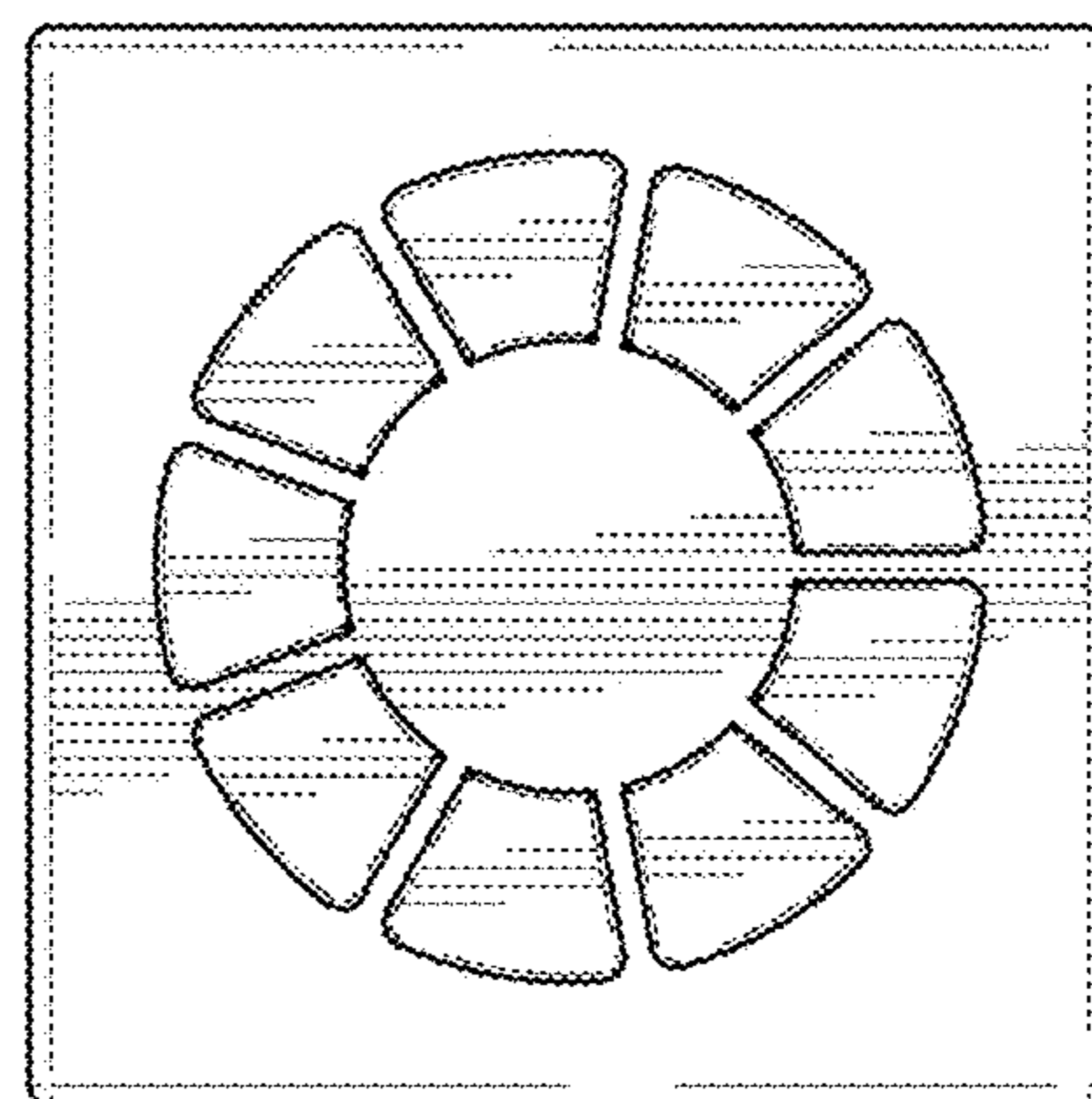

FIG. 9

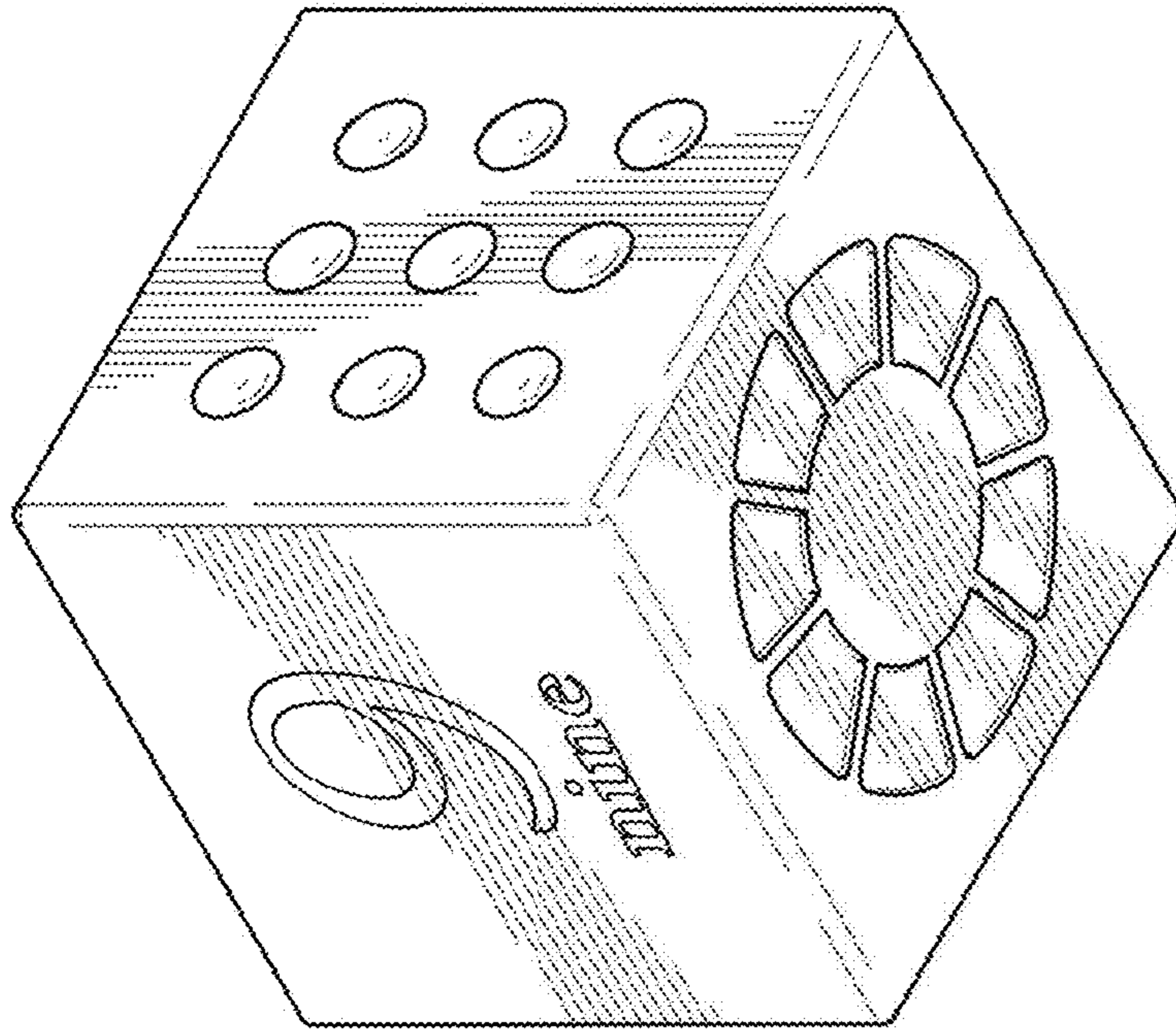

FIG. 11

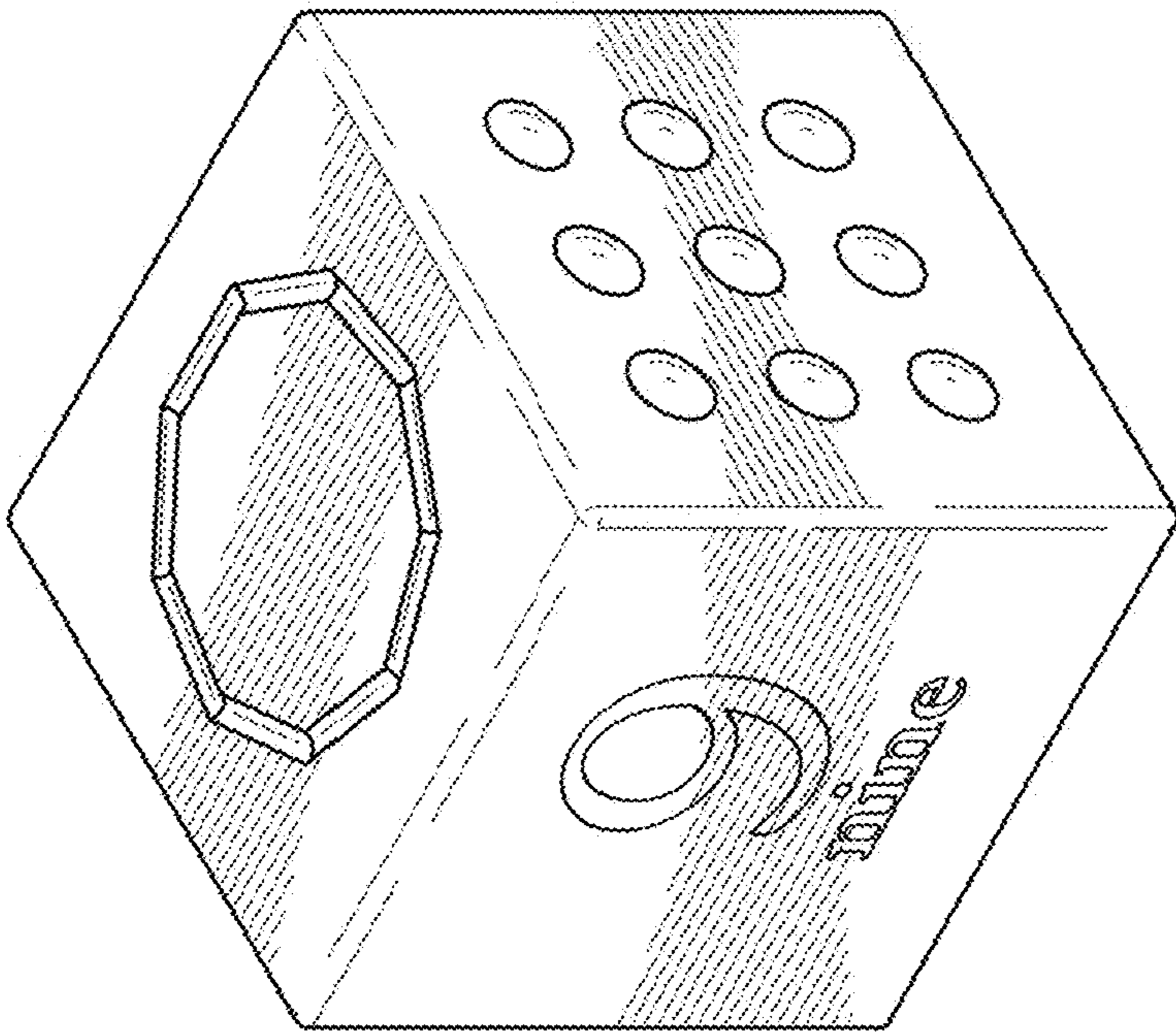

FIG. 12

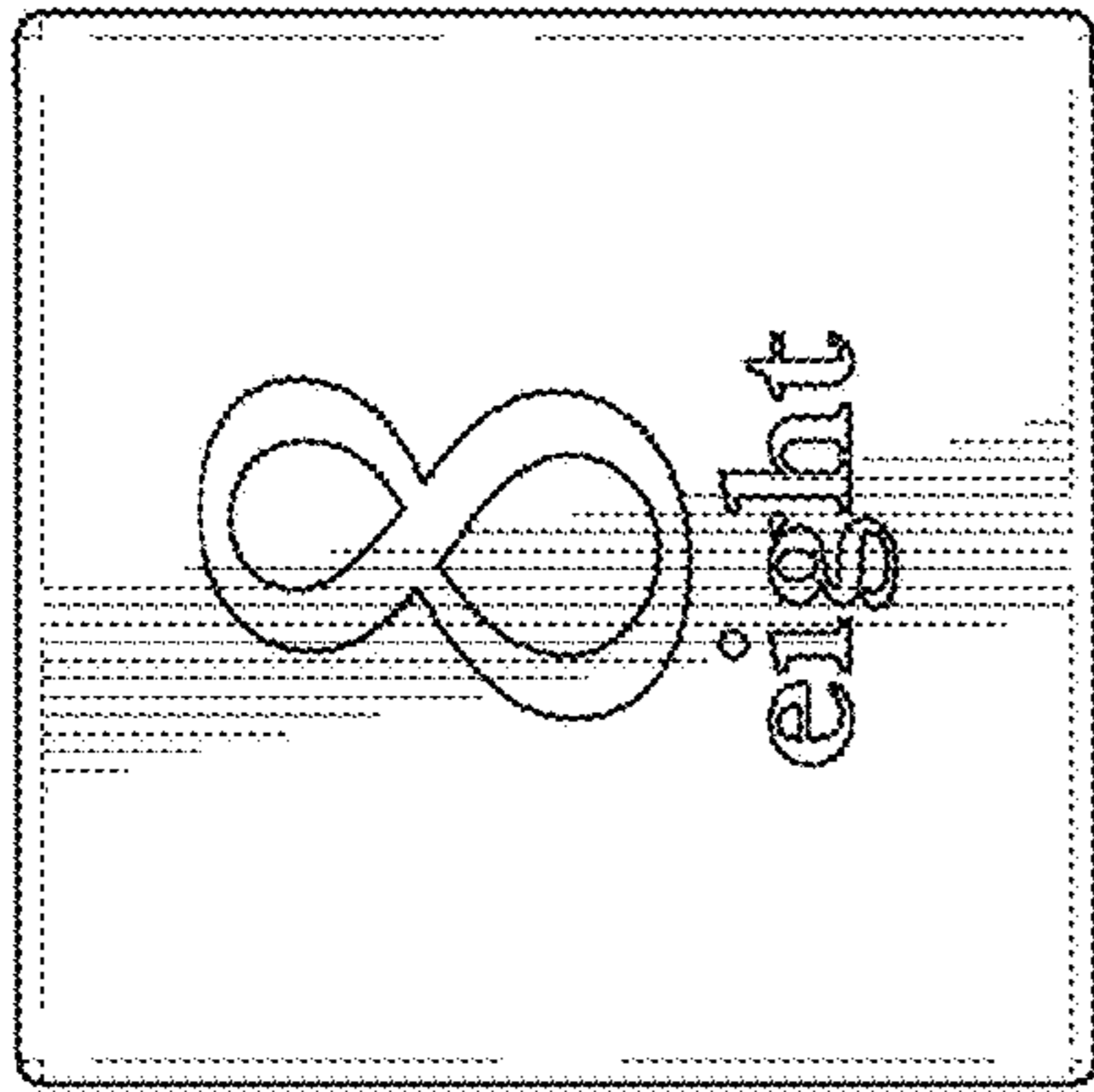

FIG. 14

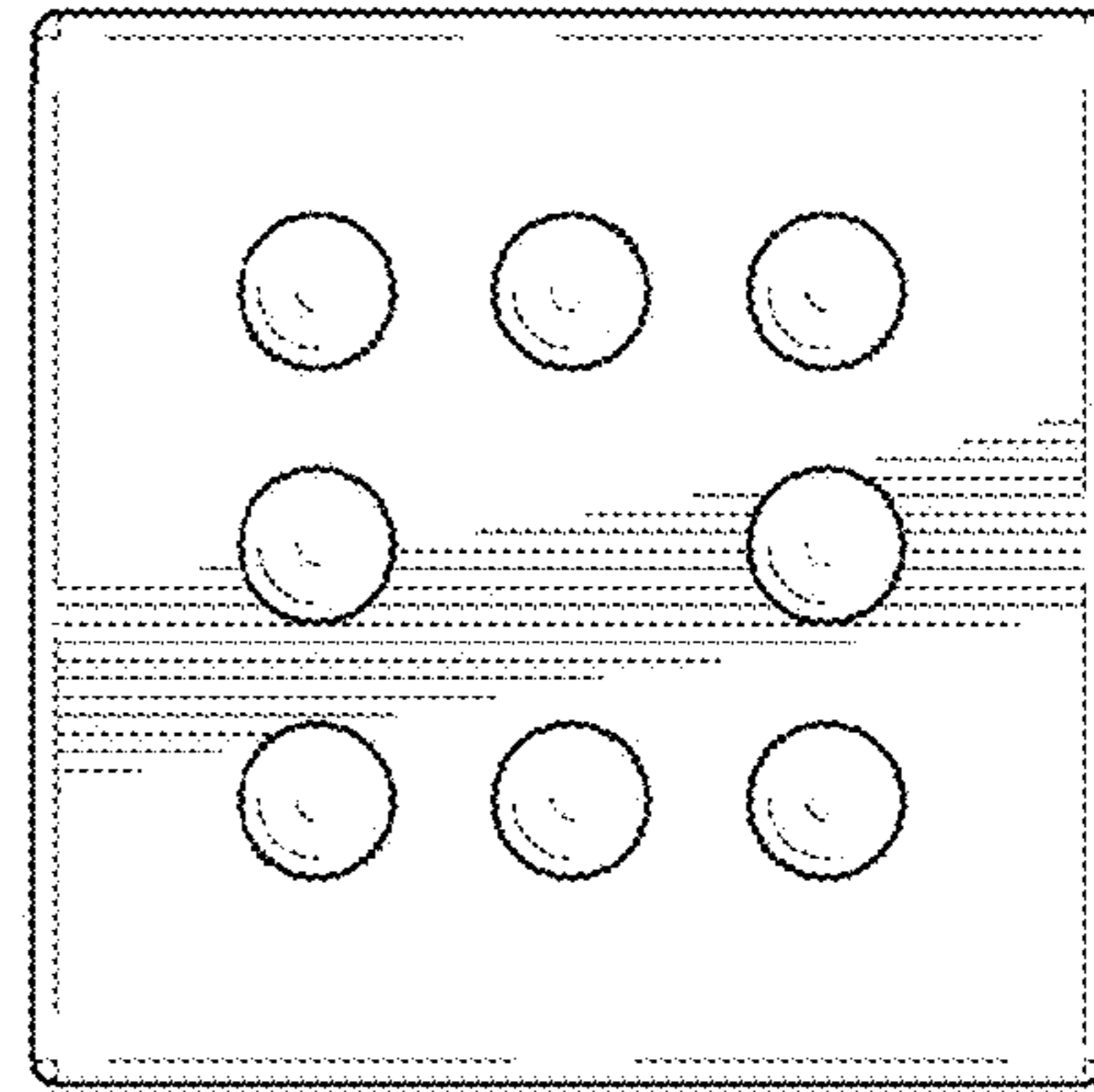

FIG. 16

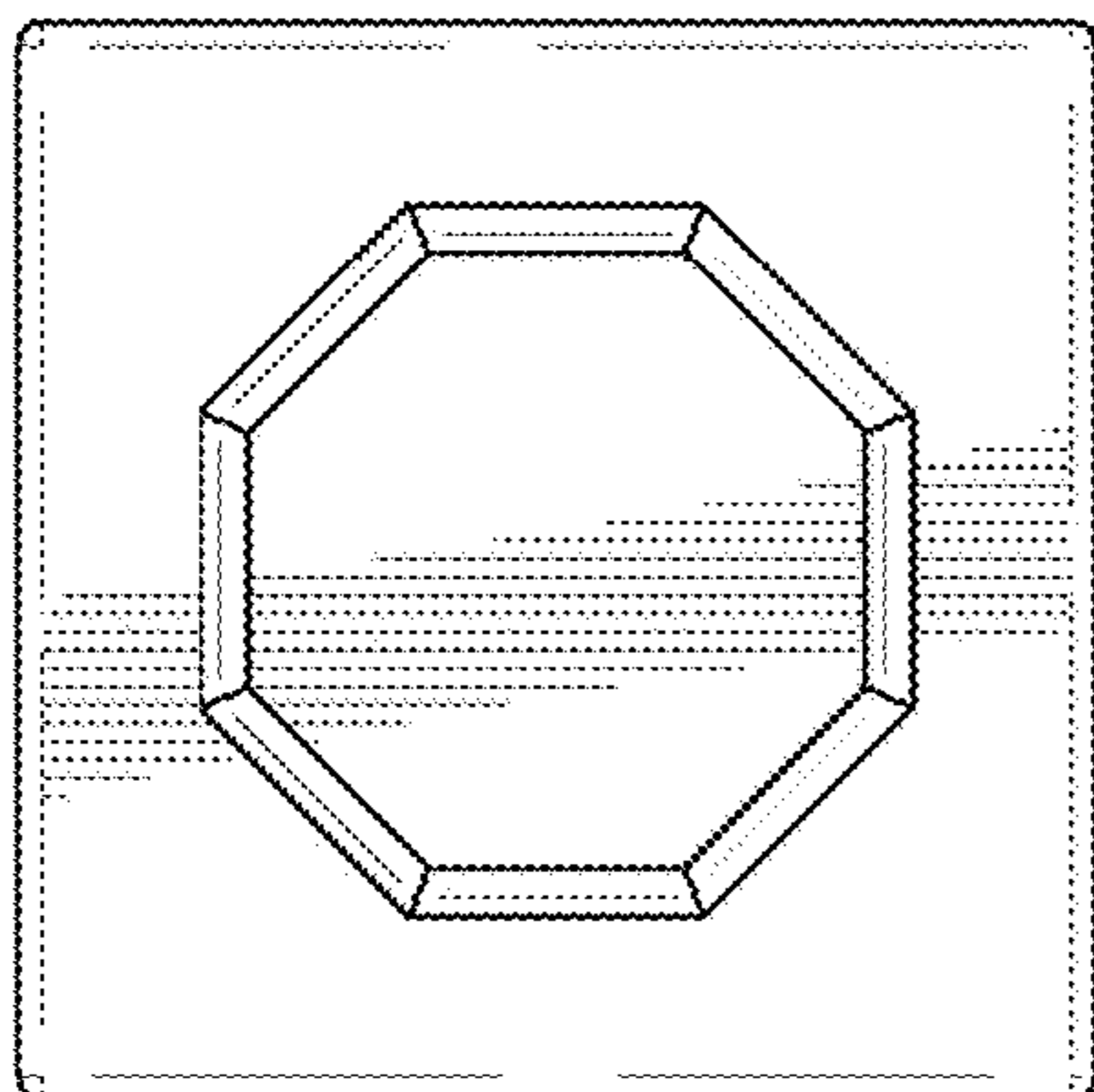

FIG. 13

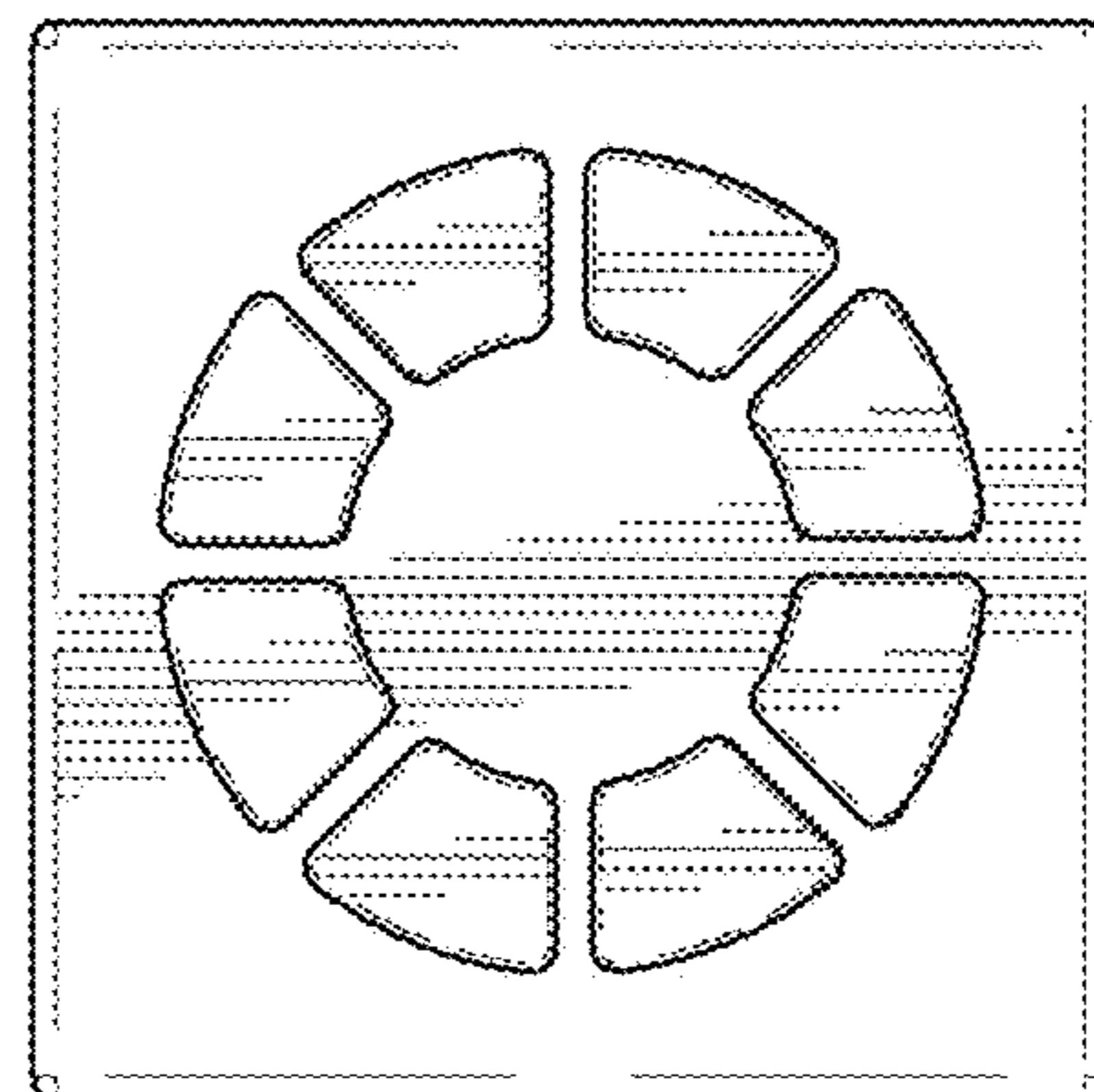

FIG. 15

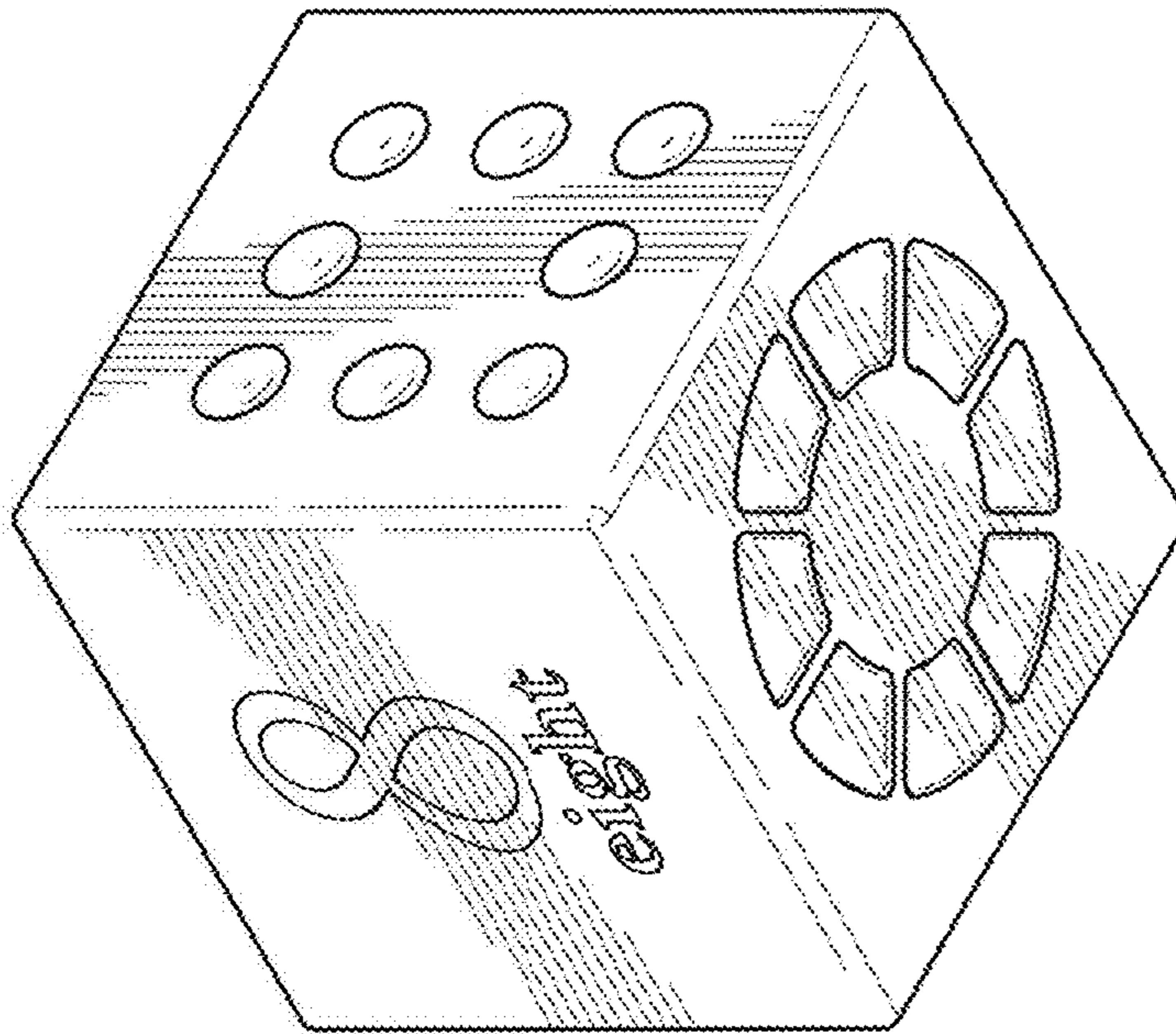

FIG. 18

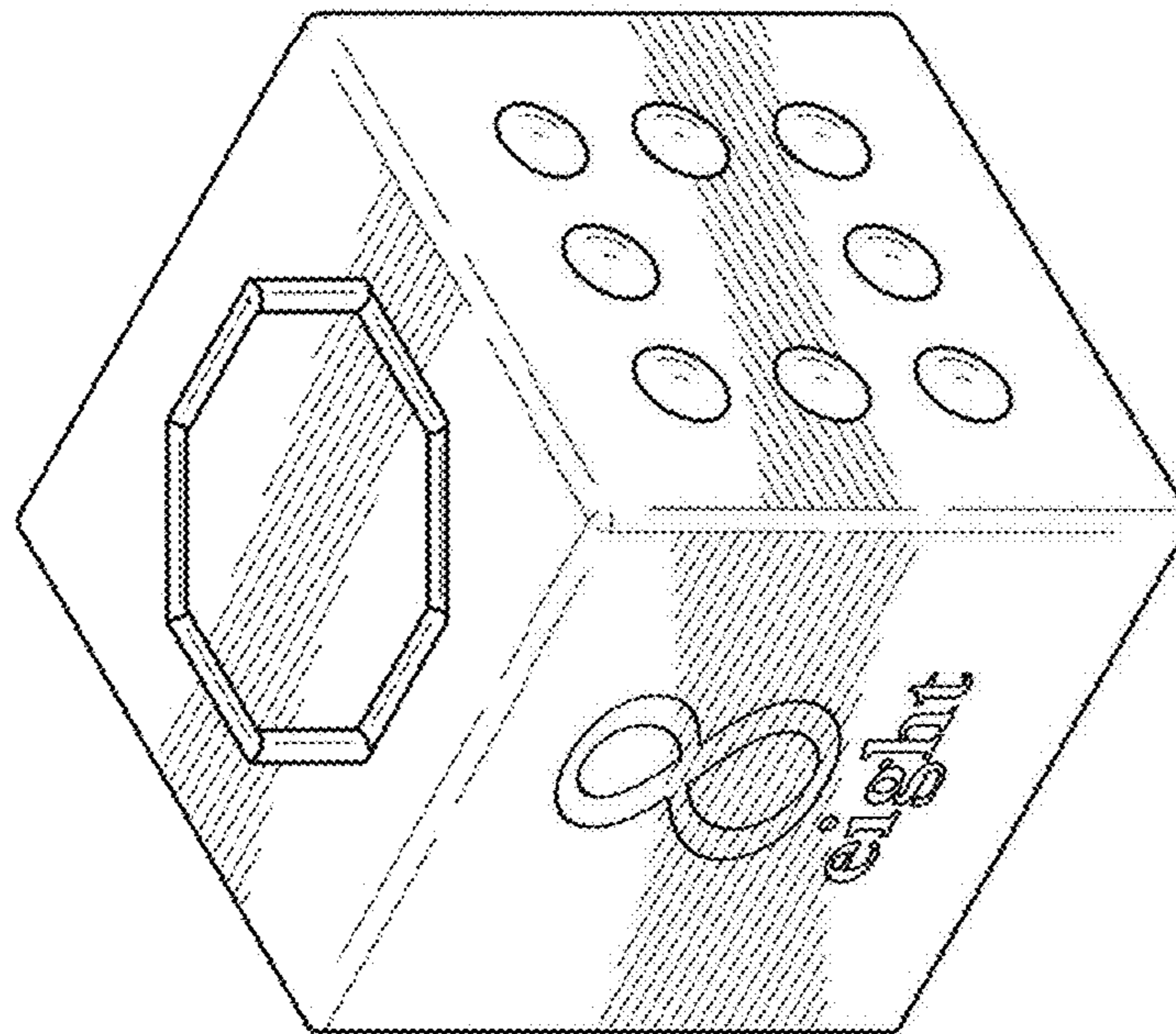

FIG. 17

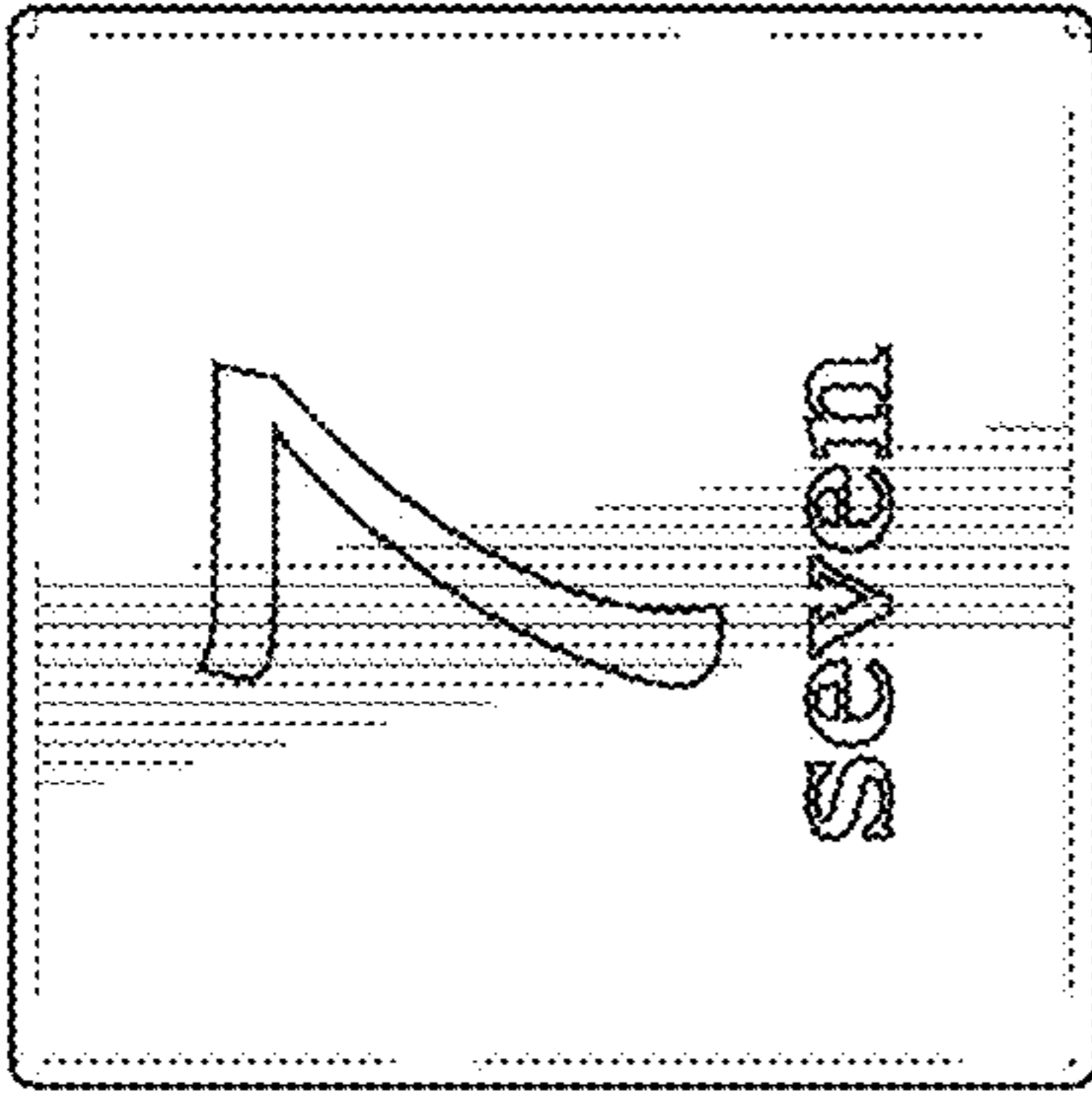

FIG. 19

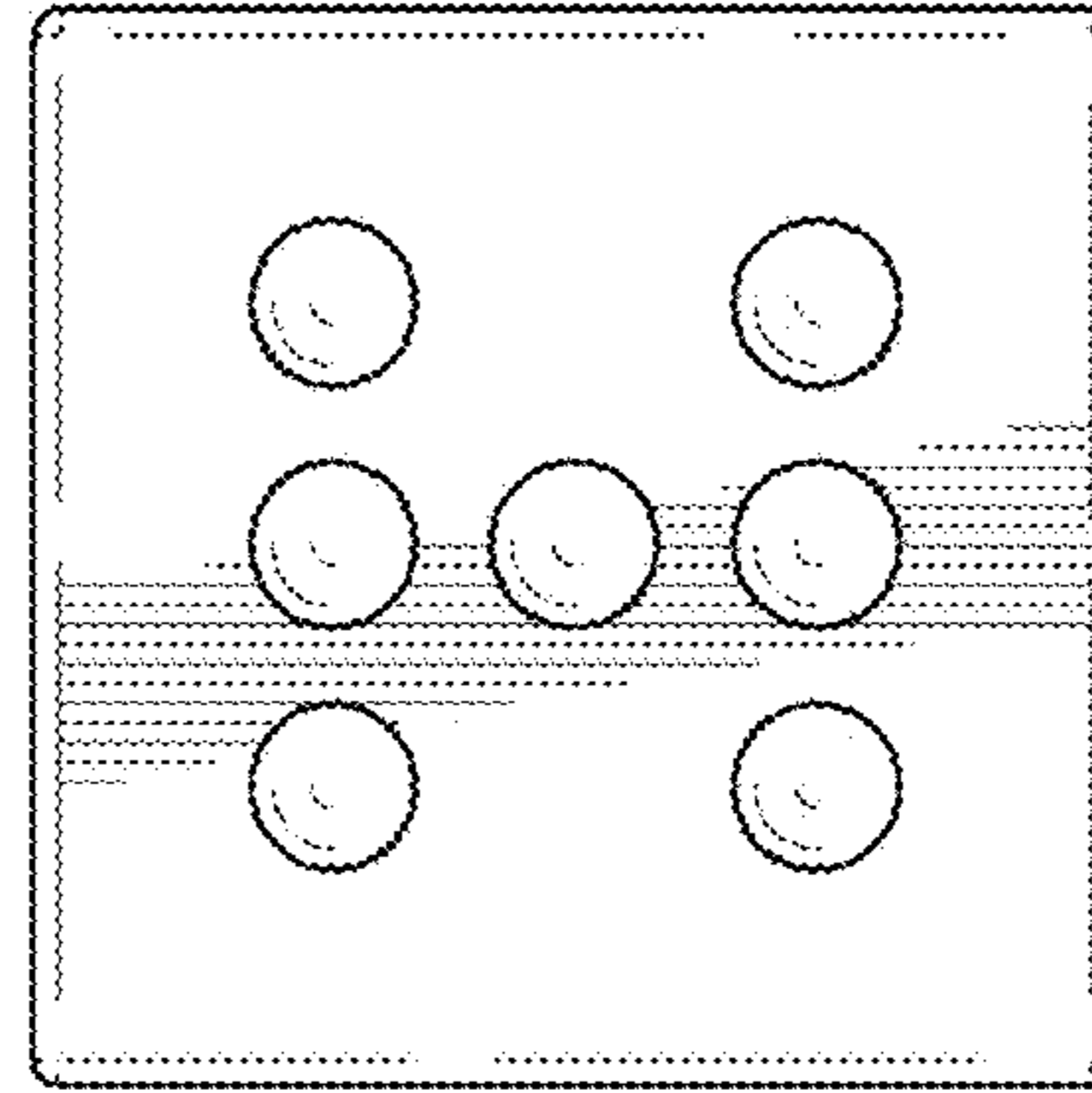

FIG. 20

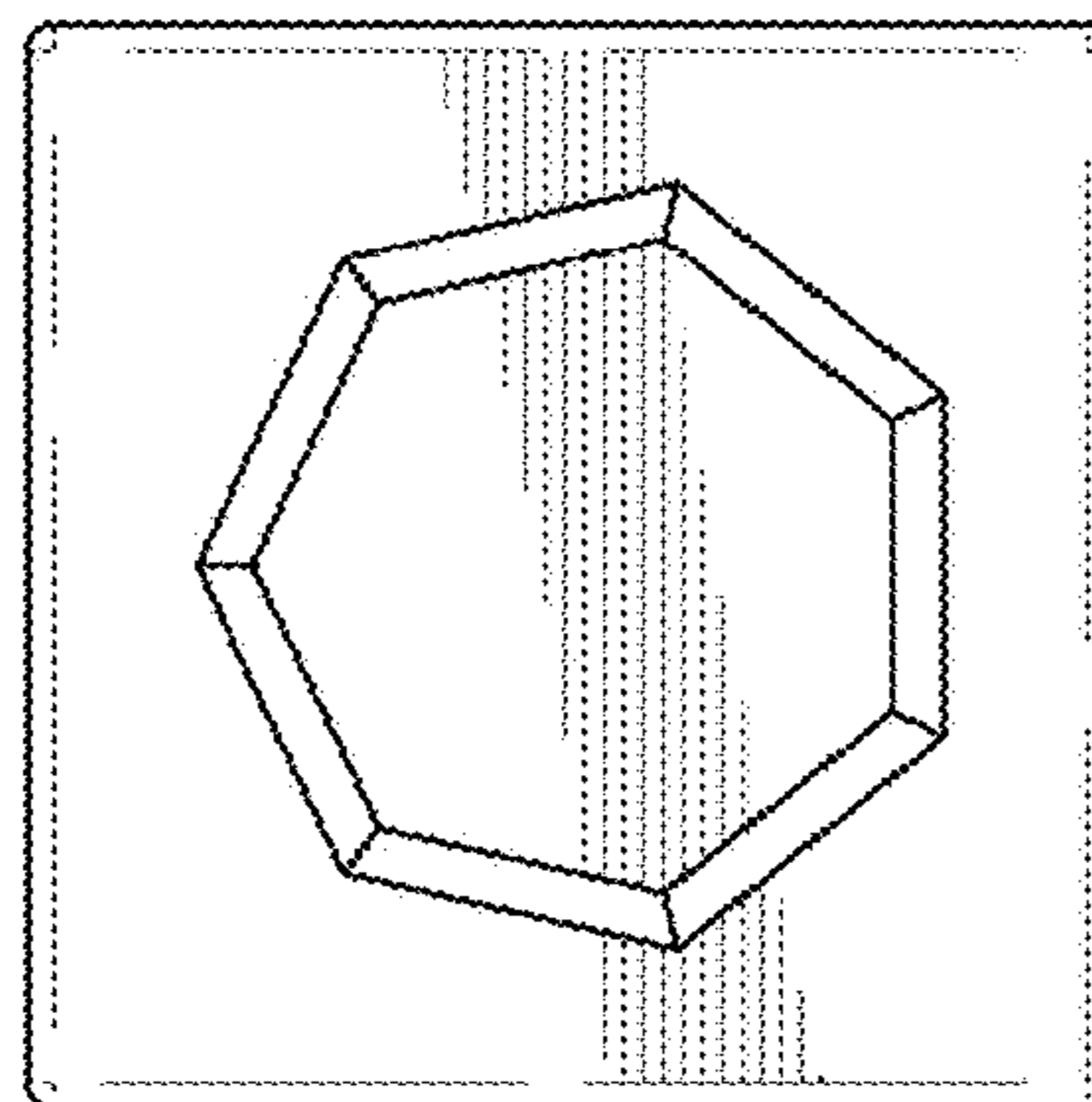

FIG. 21

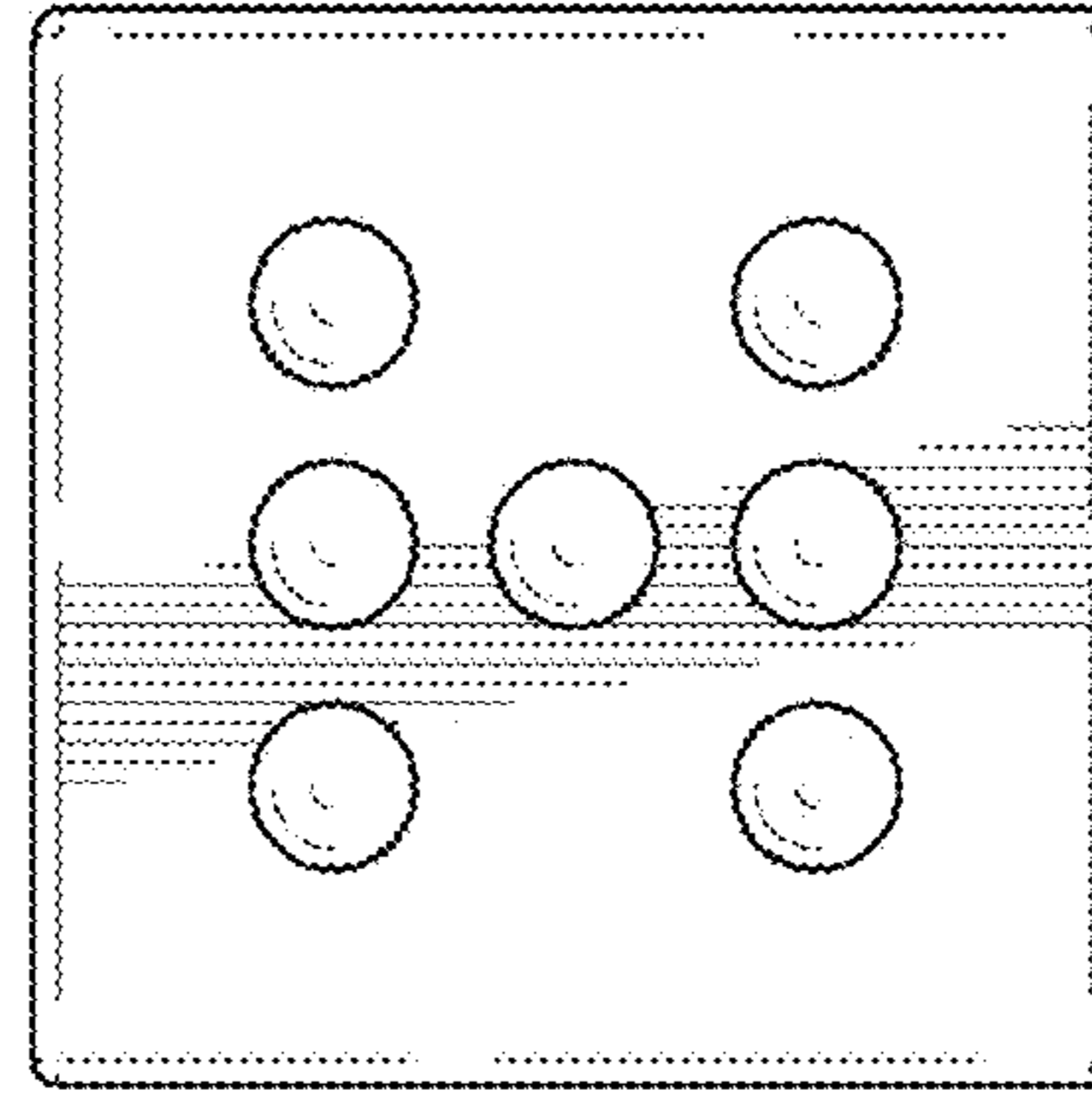

FIG. 22

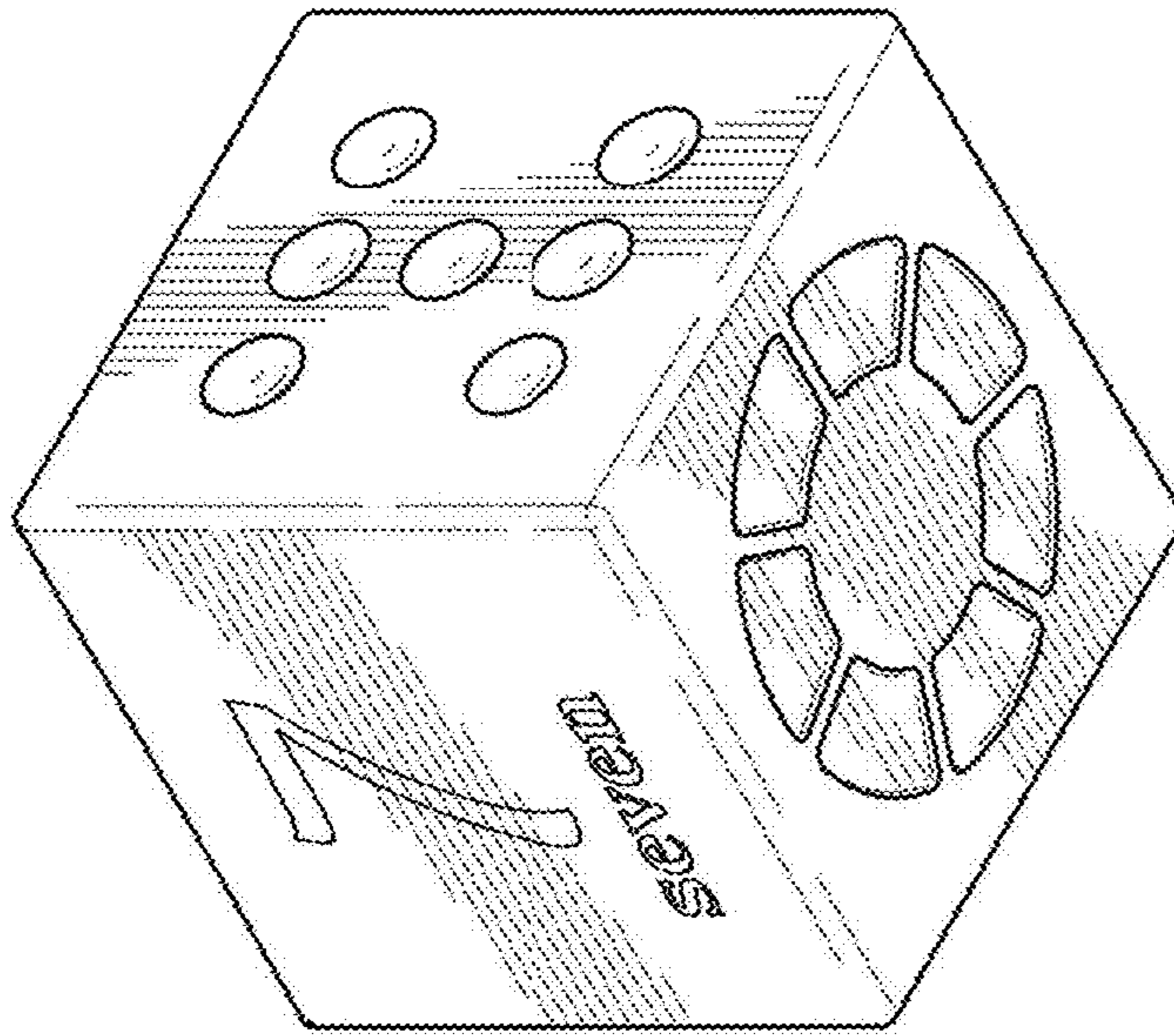

FIG. 24

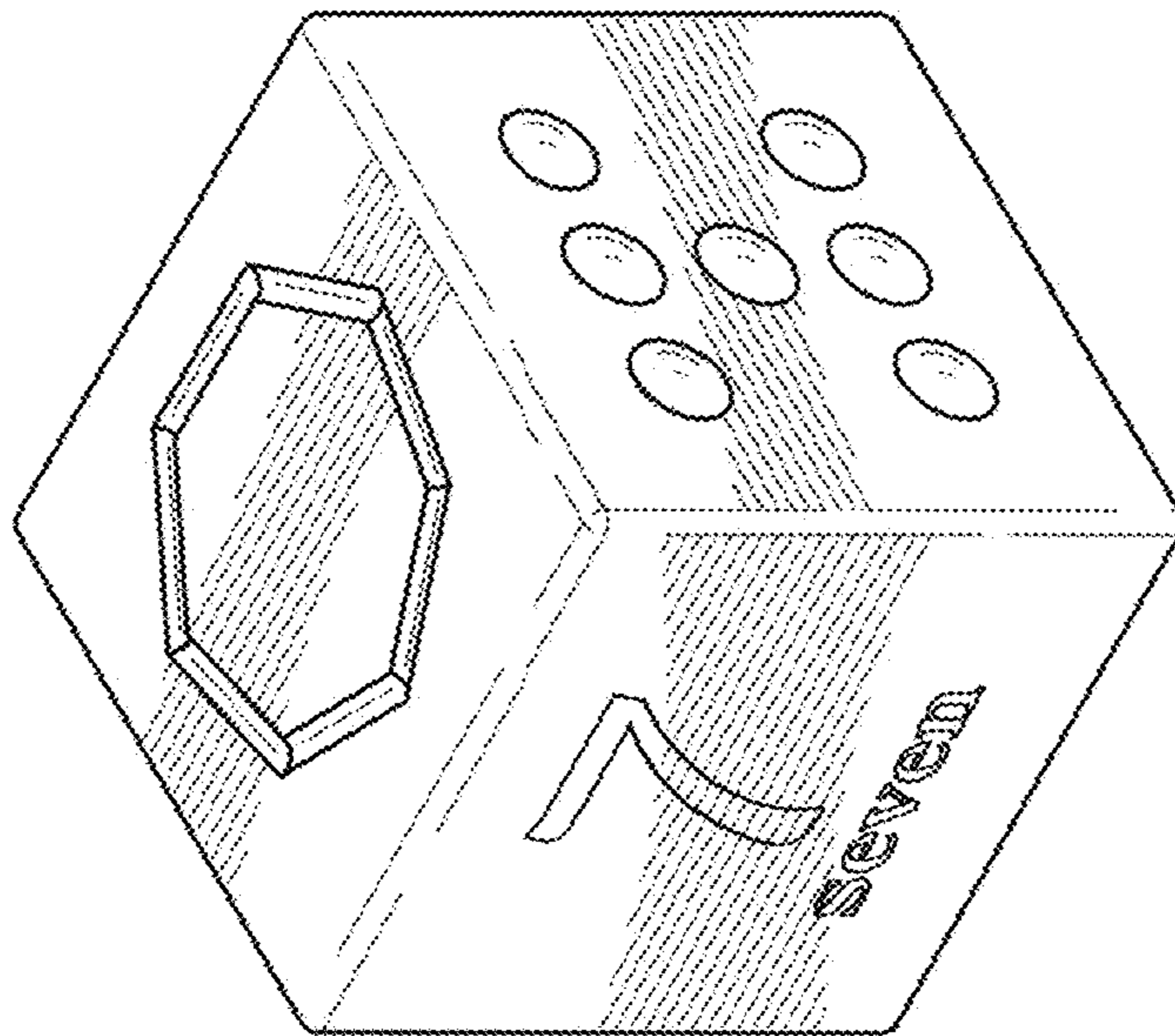

FIG. 23

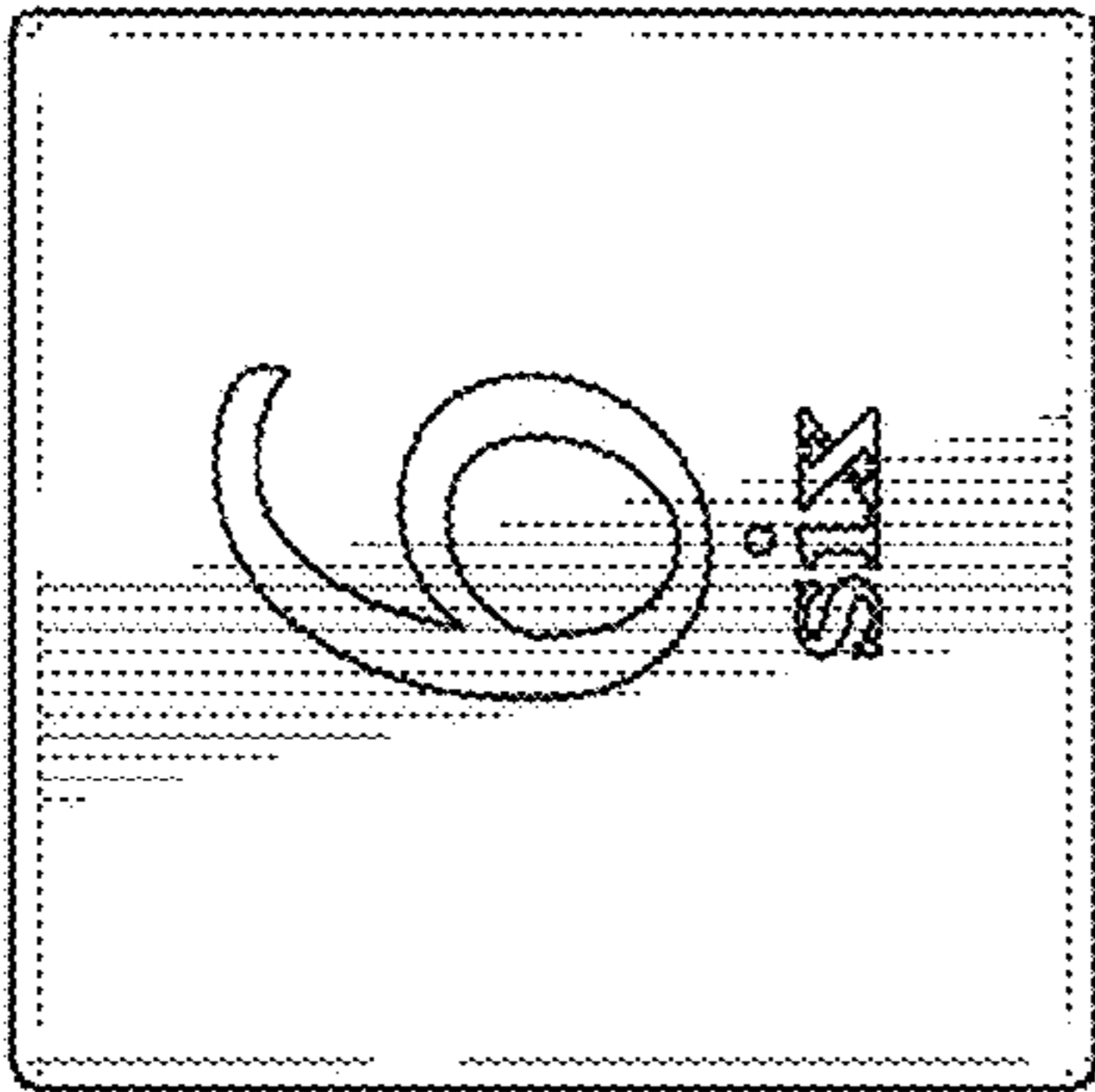

FIG. 26

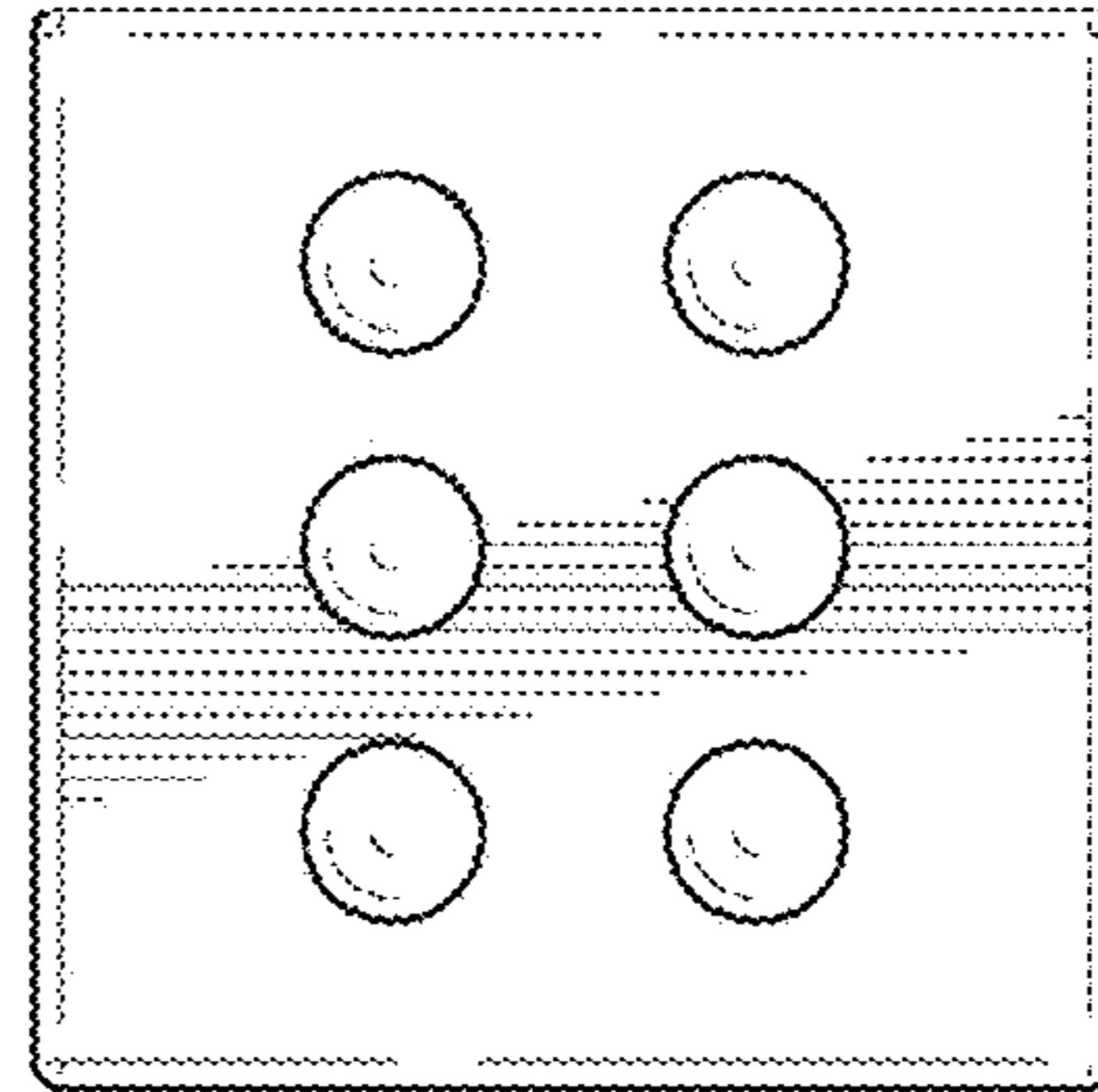

FIG. 28

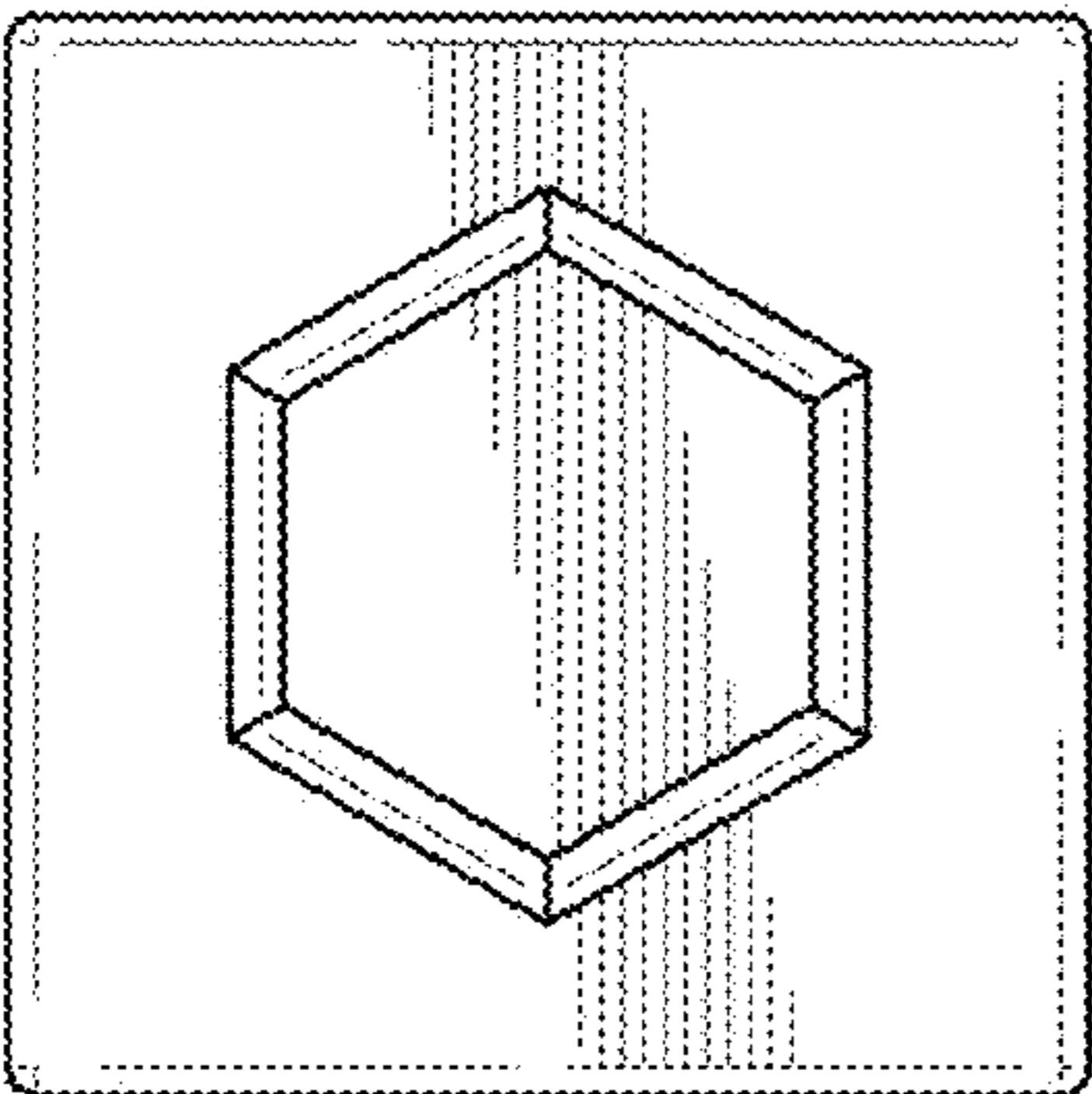

FIG. 25

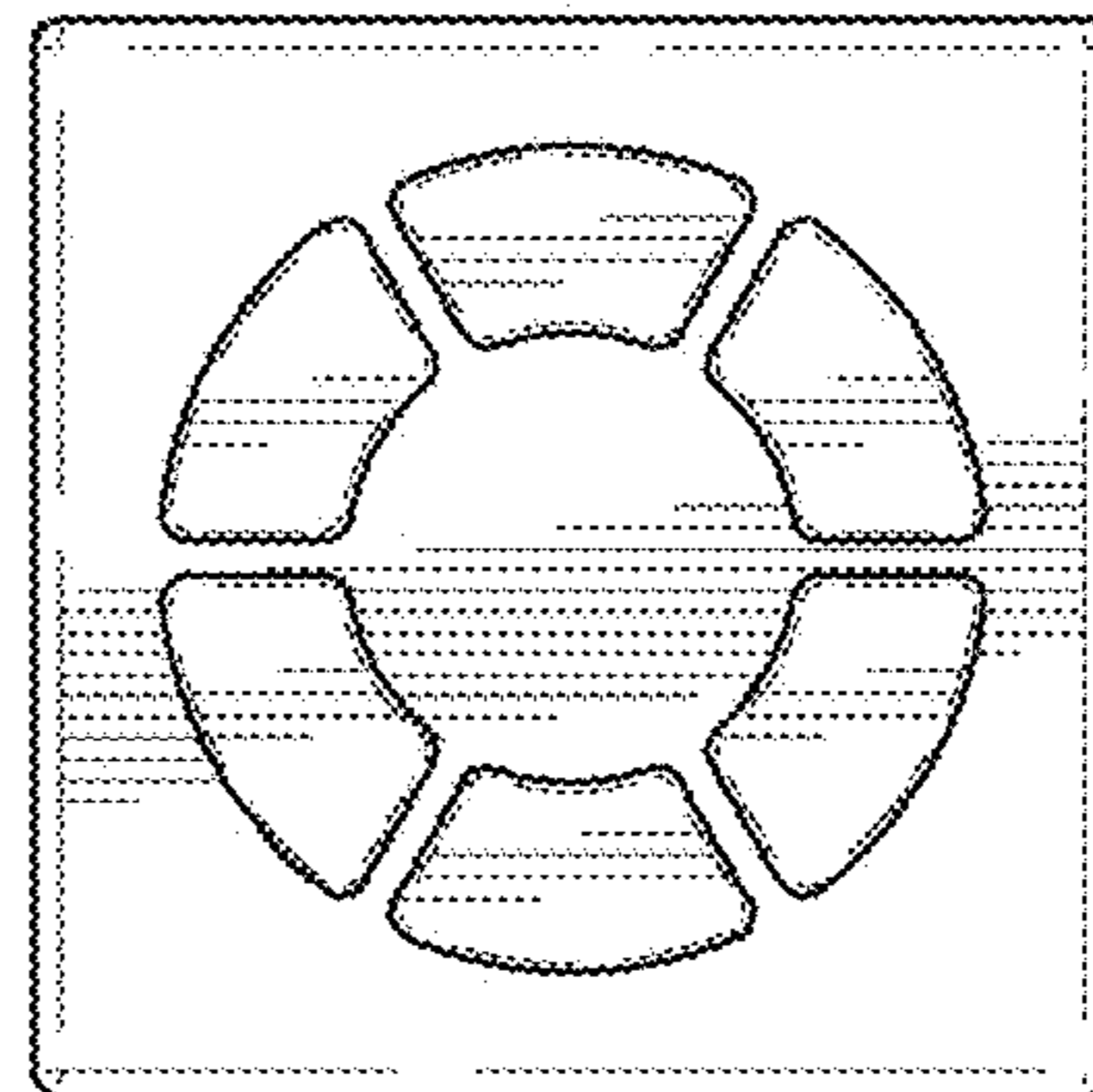

FIG. 27

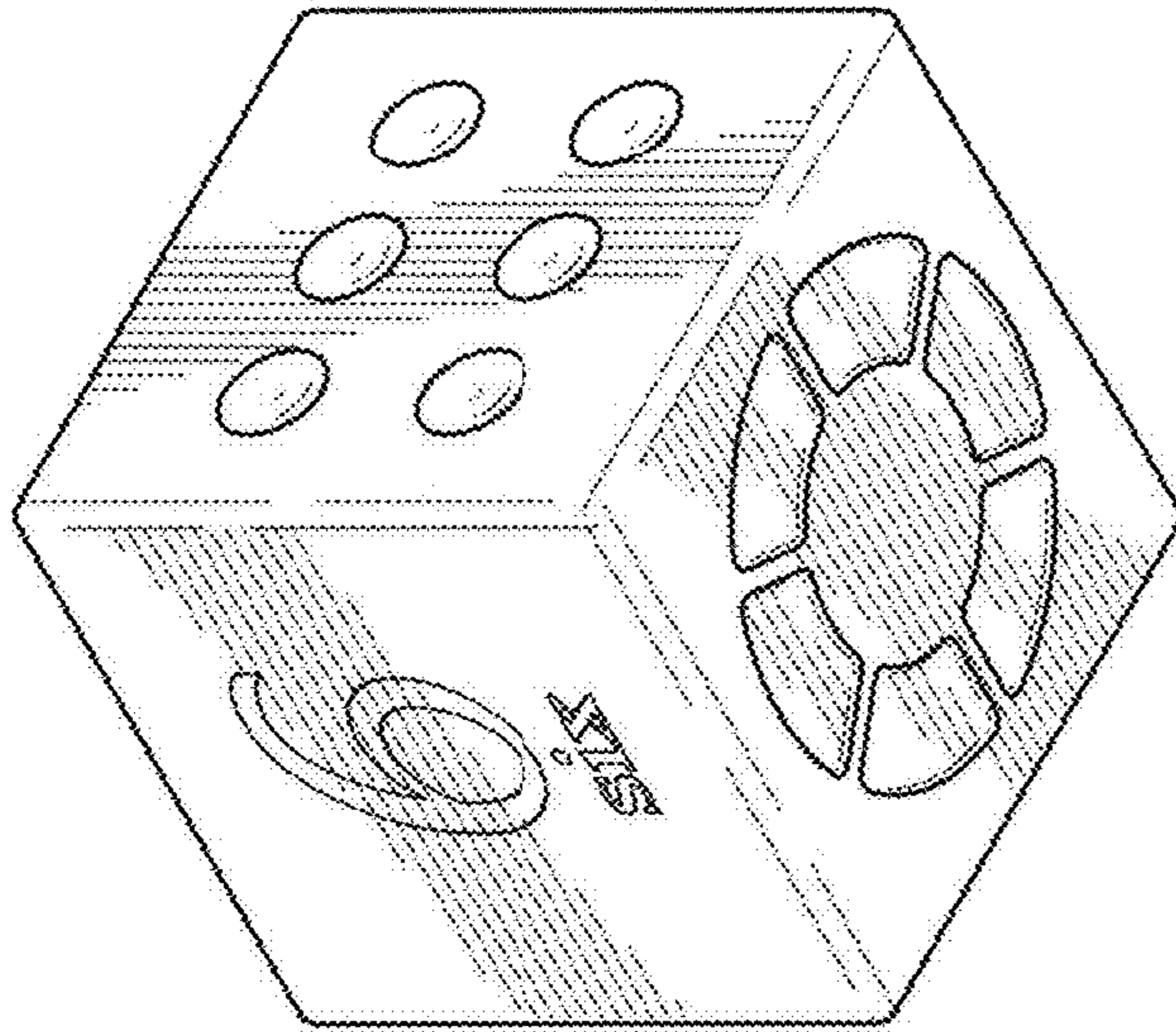

FIG. 29

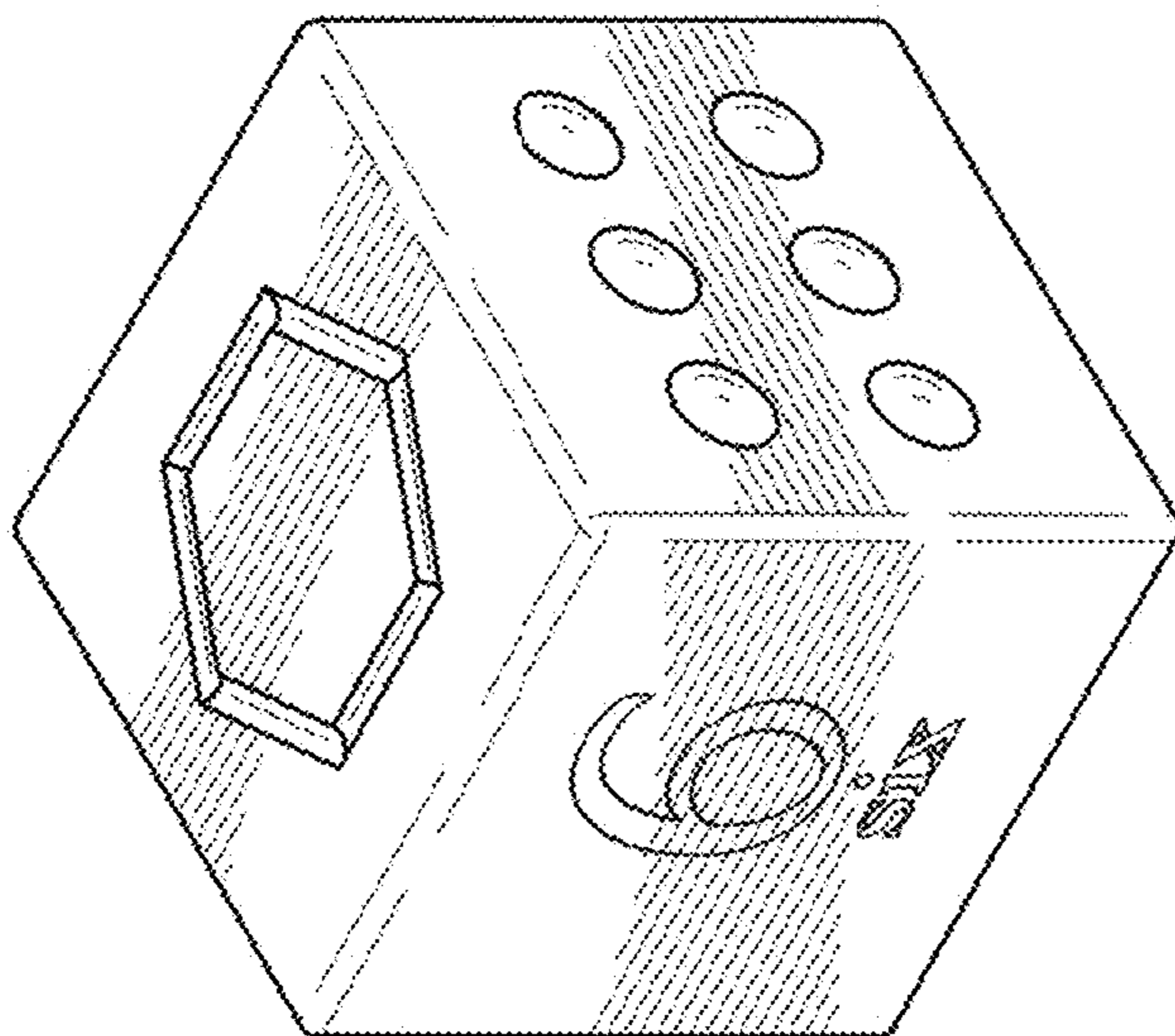

FIG. 30

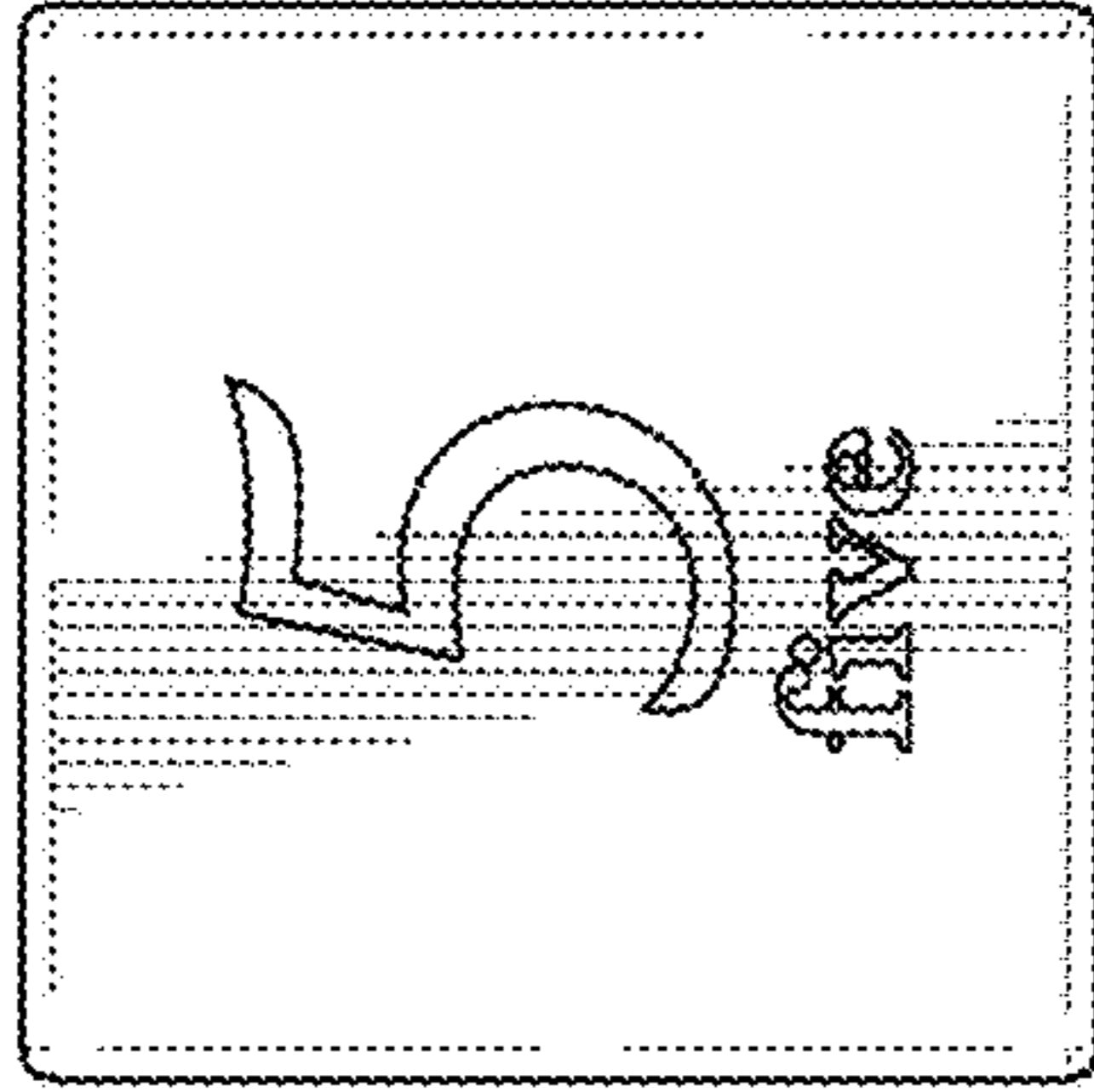

FIG. 32

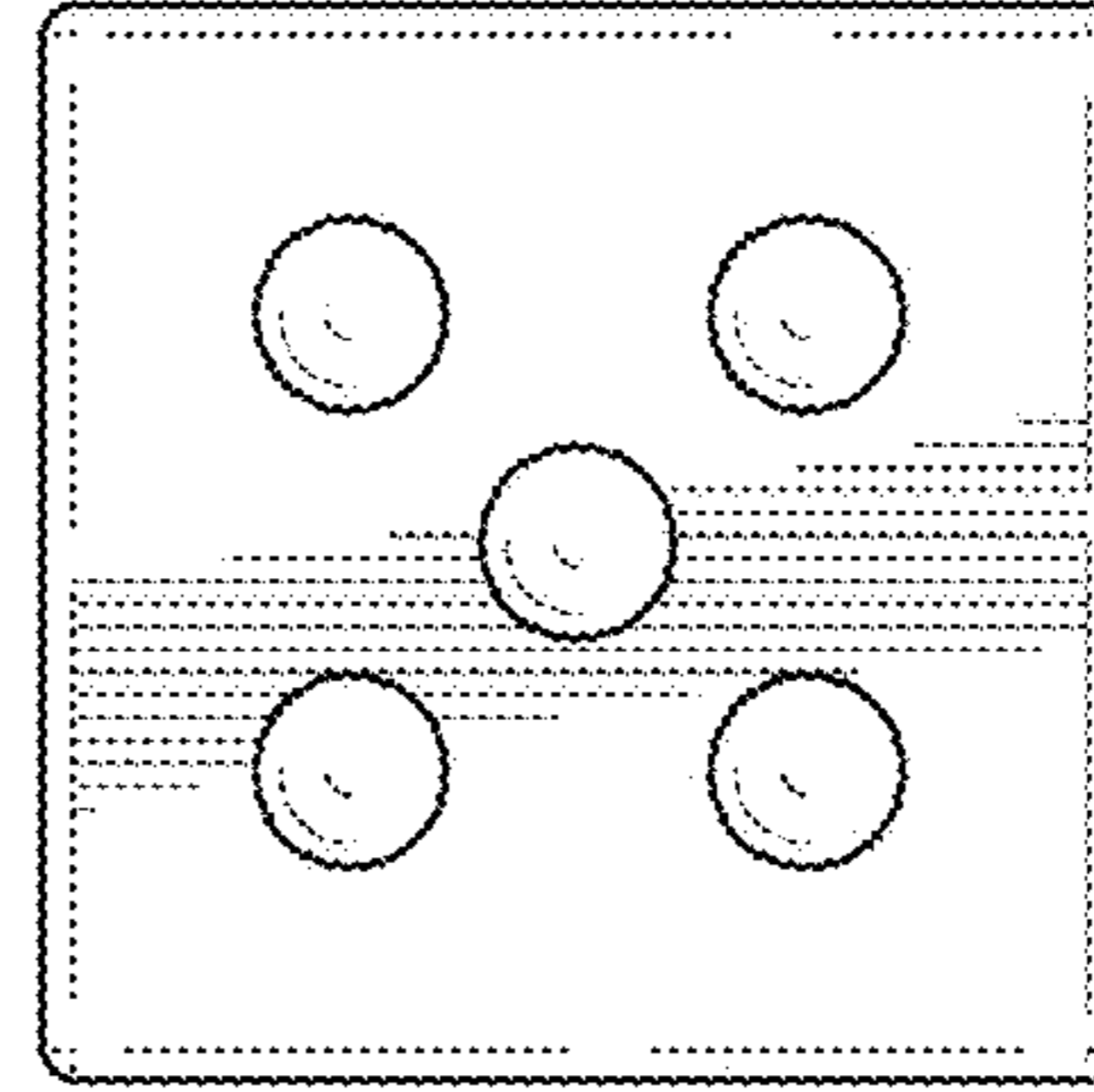

FIG. 34

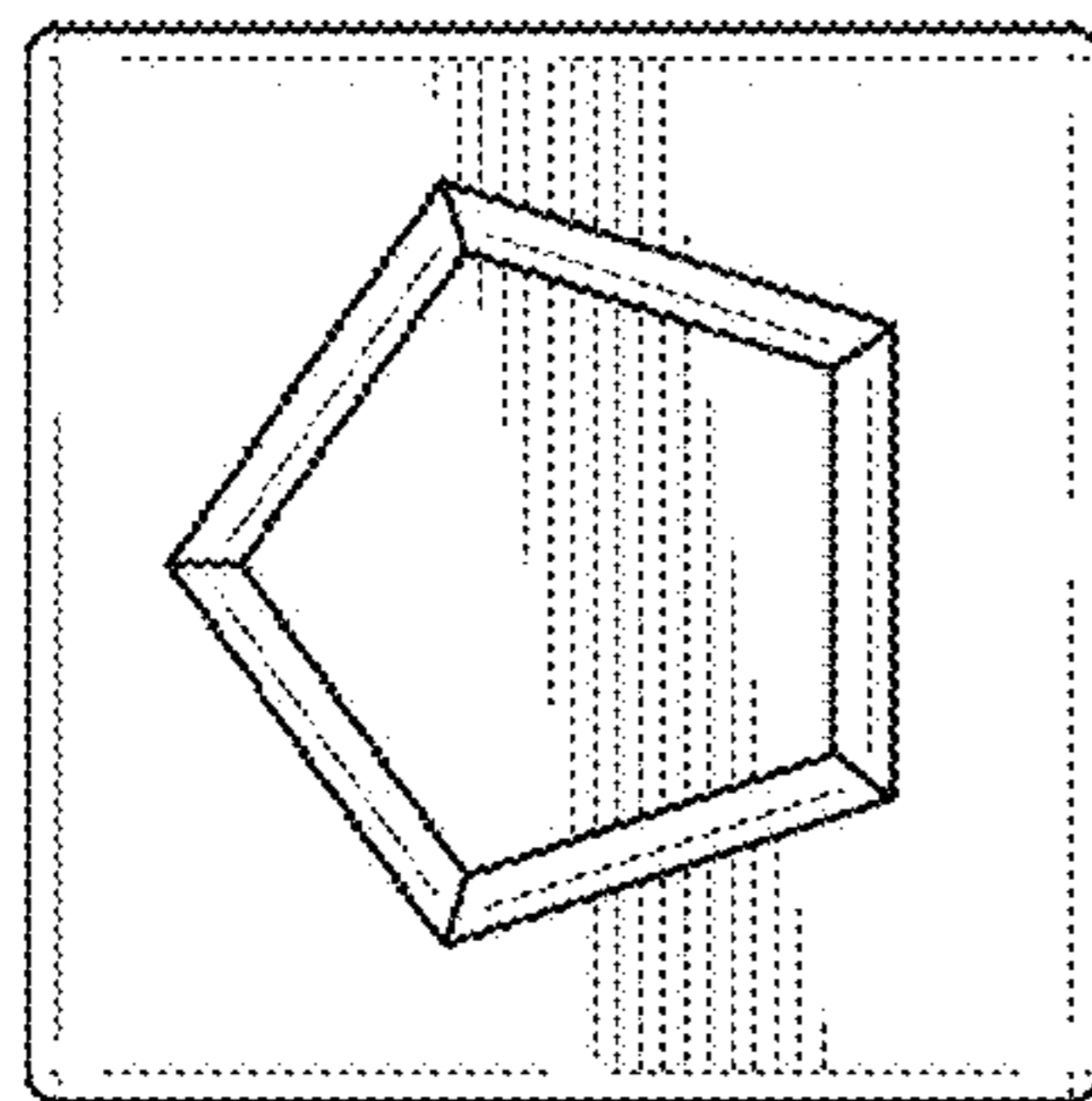

FIG. 31

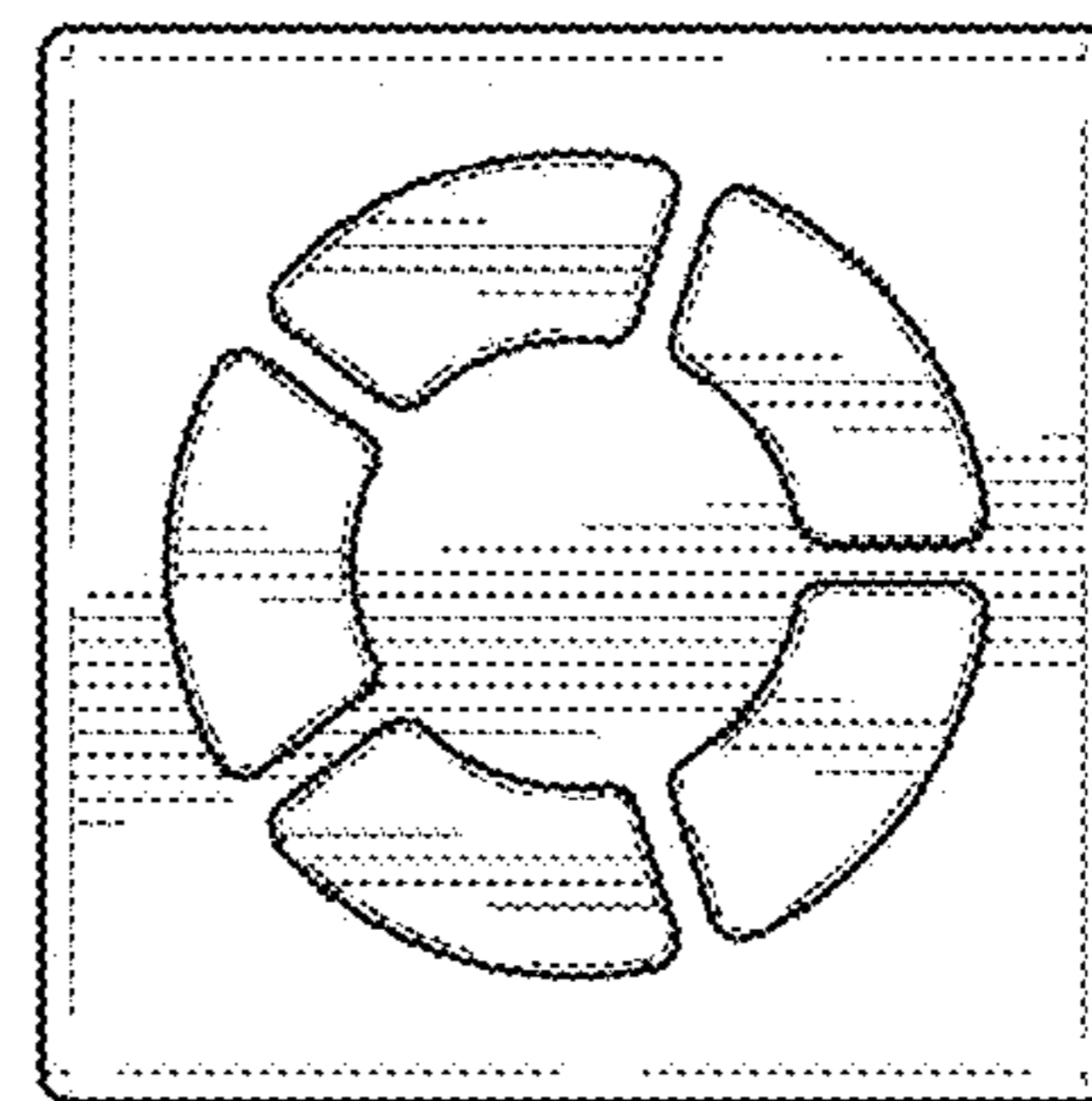

FIG. 33

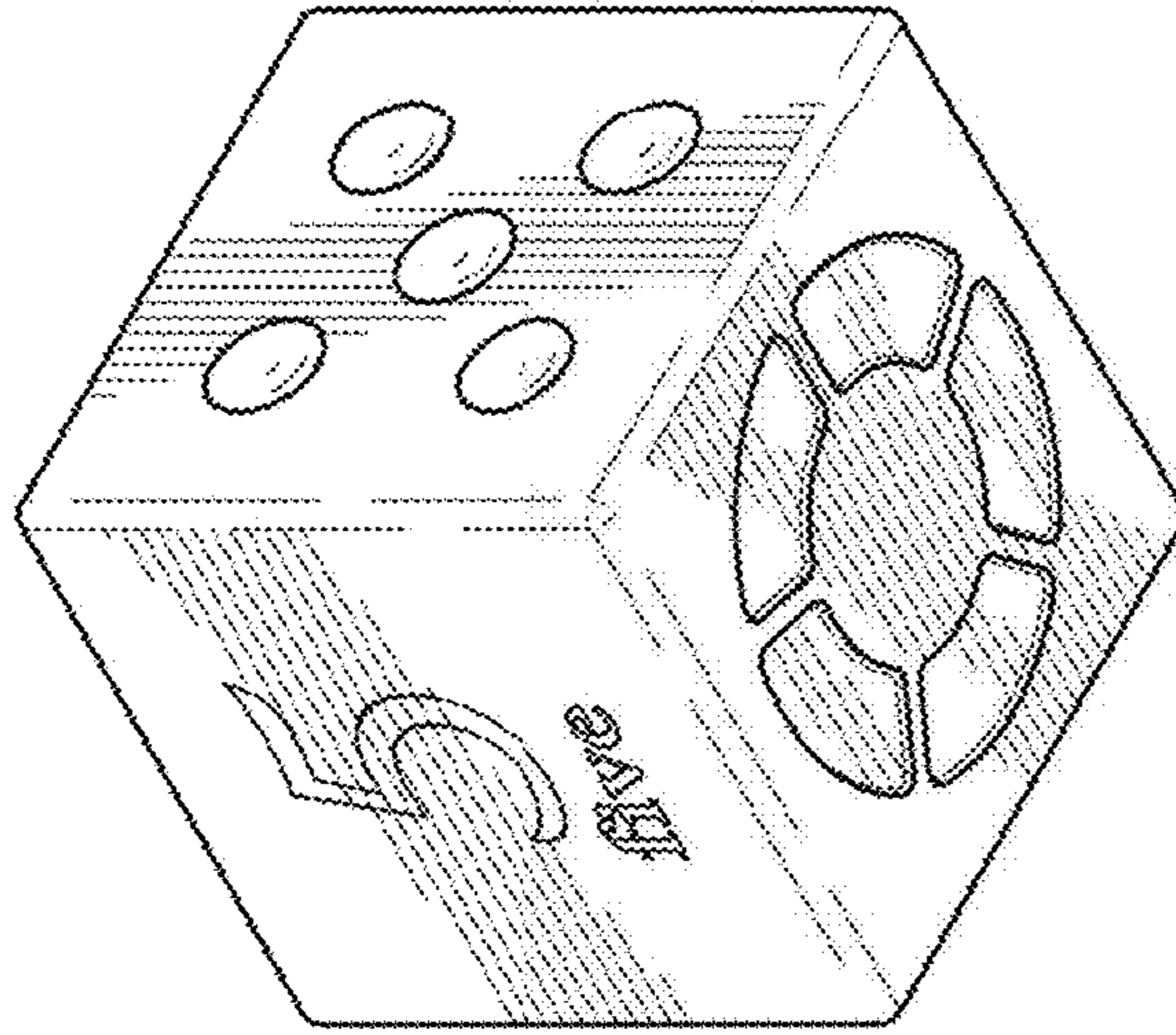

FIG. 35

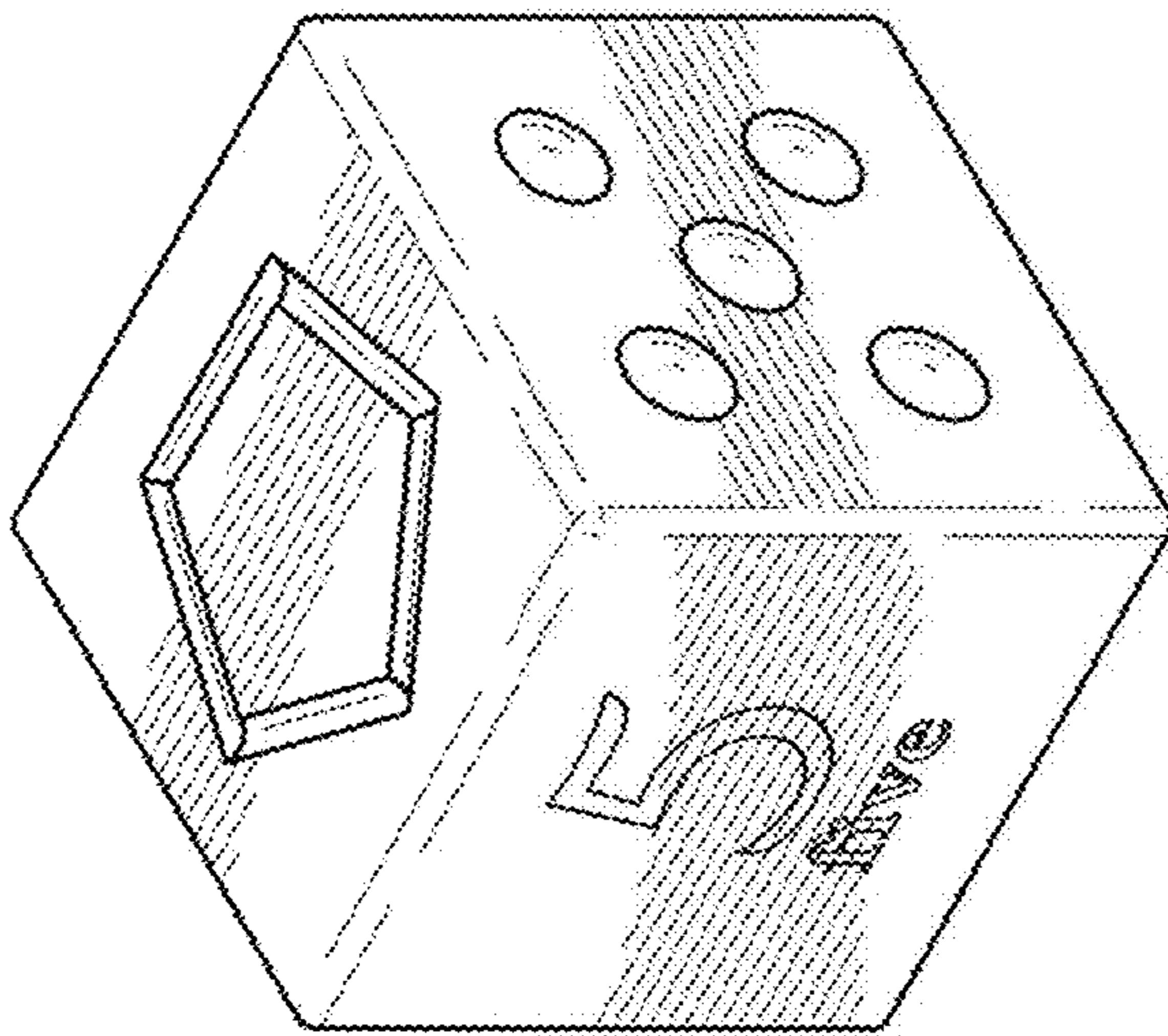

FIG. 36

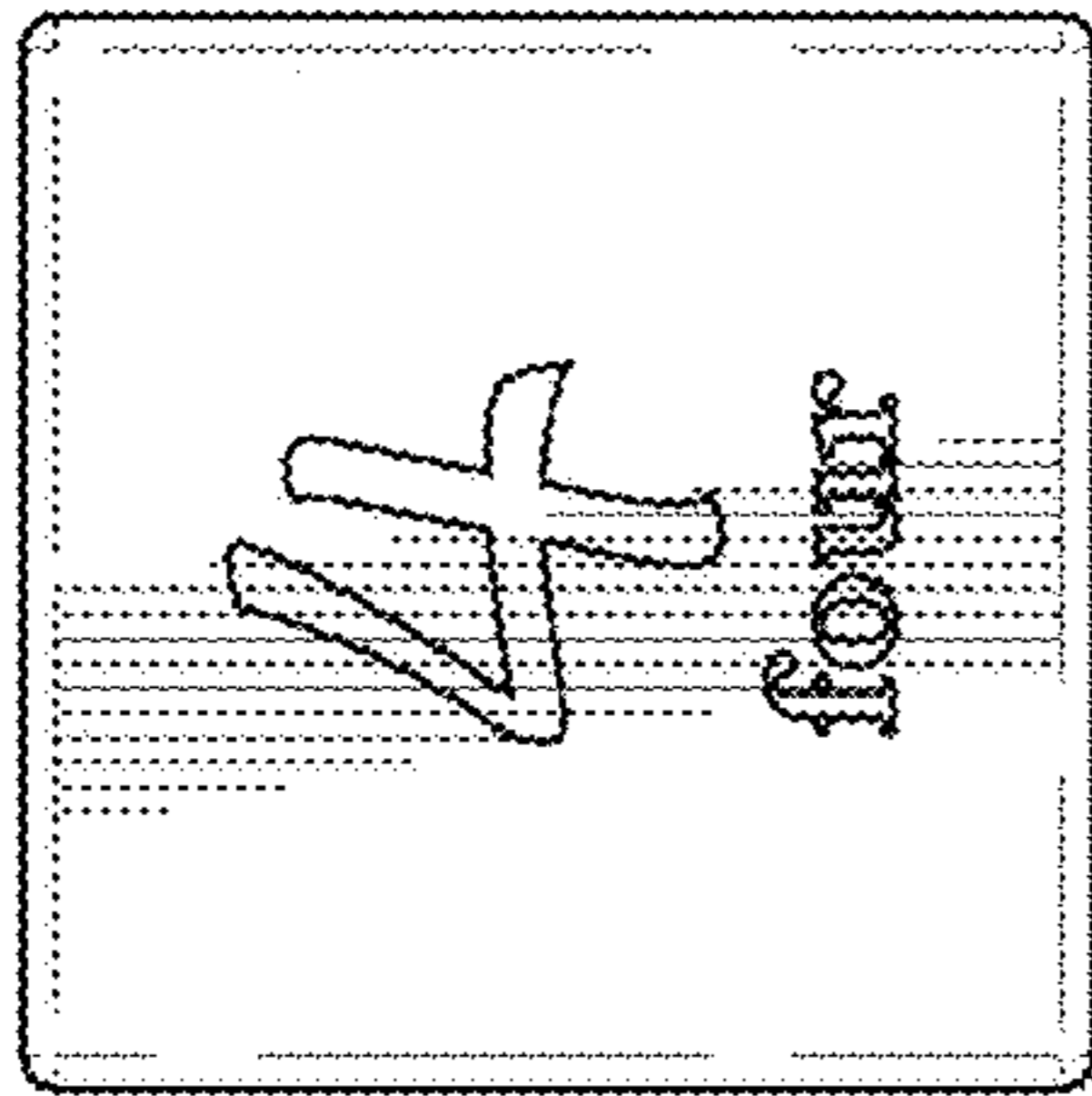

FIG. 37

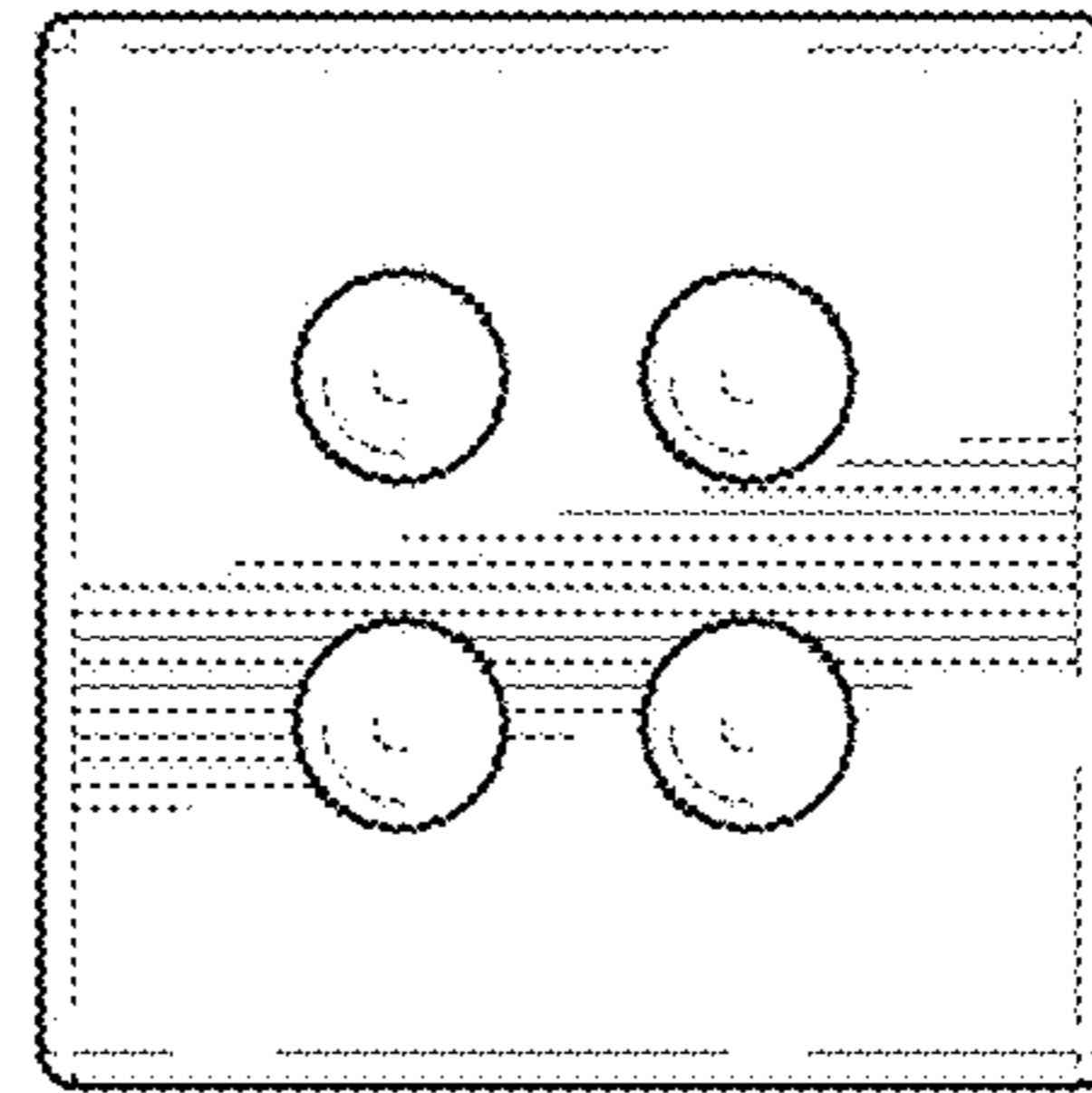

FIG. 38

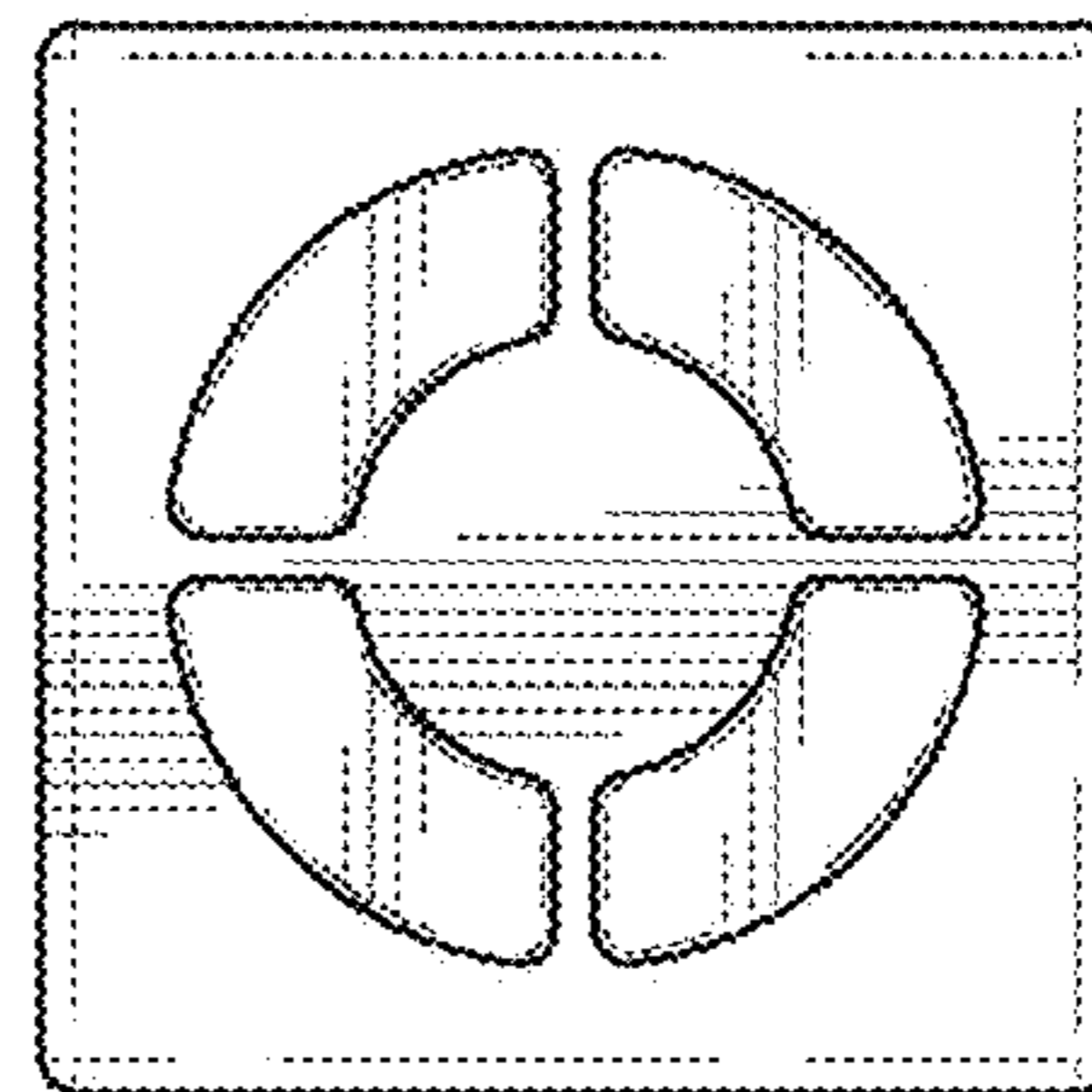

FIG. 39

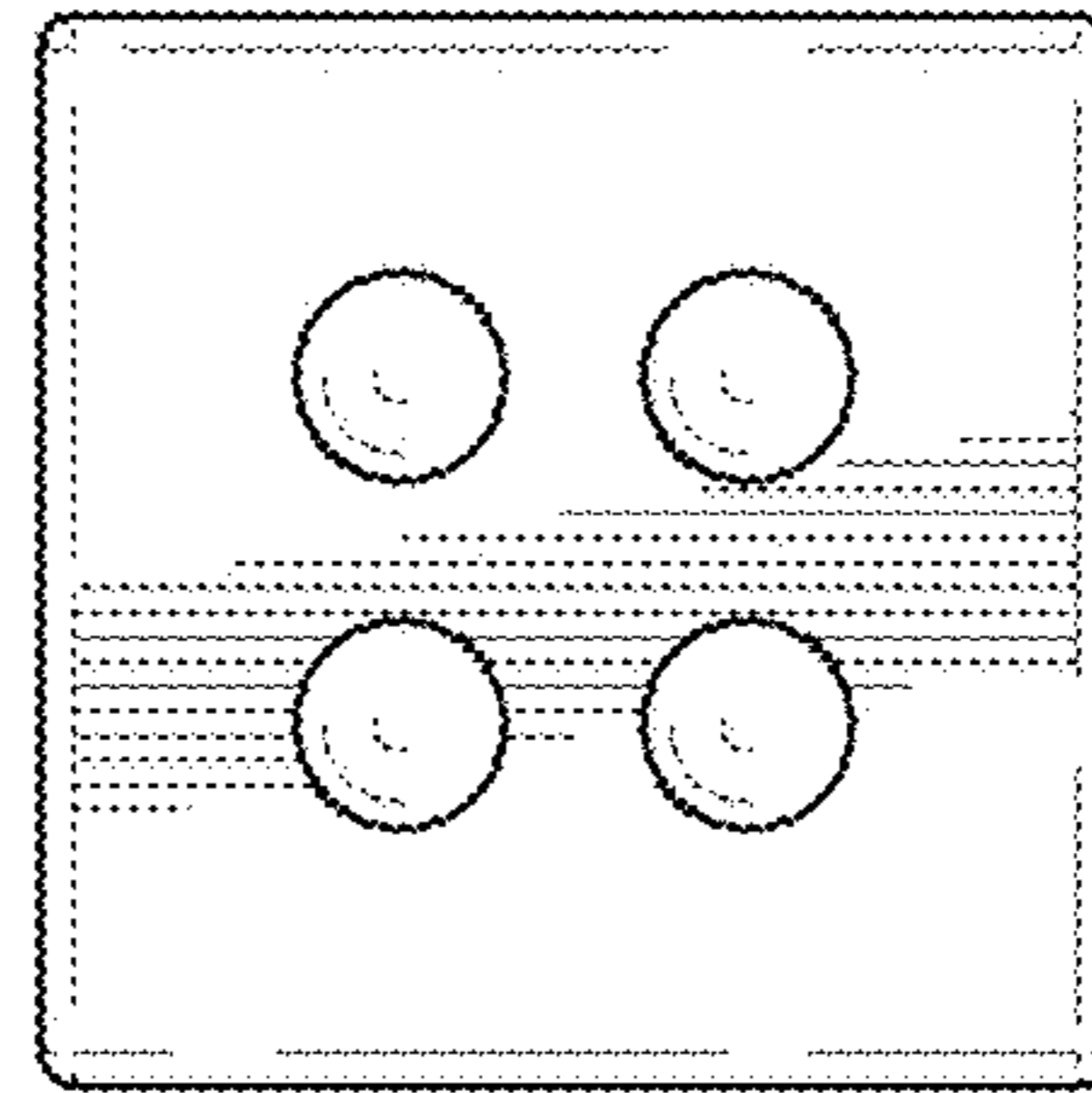

FIG. 40

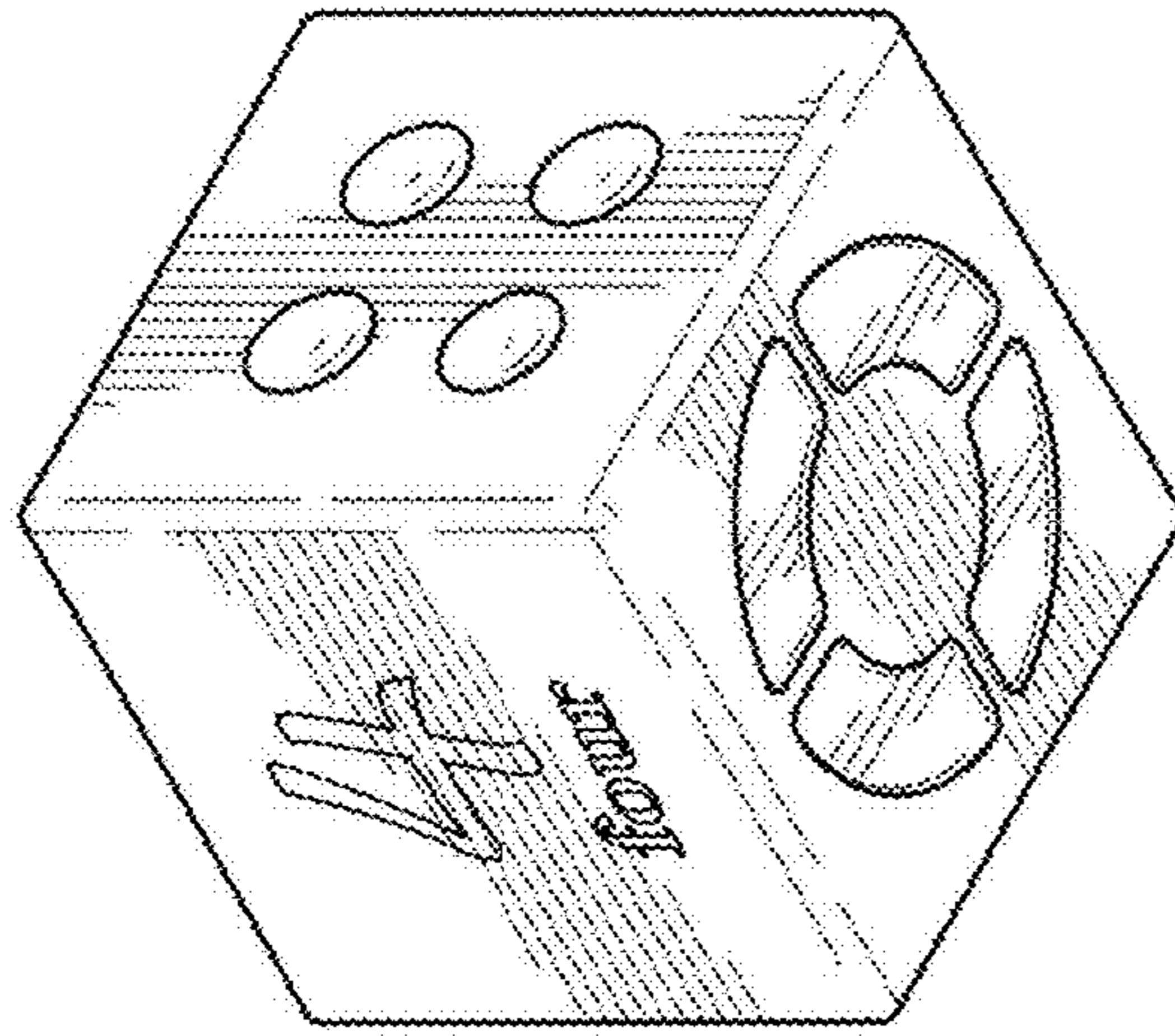

FIG. 42

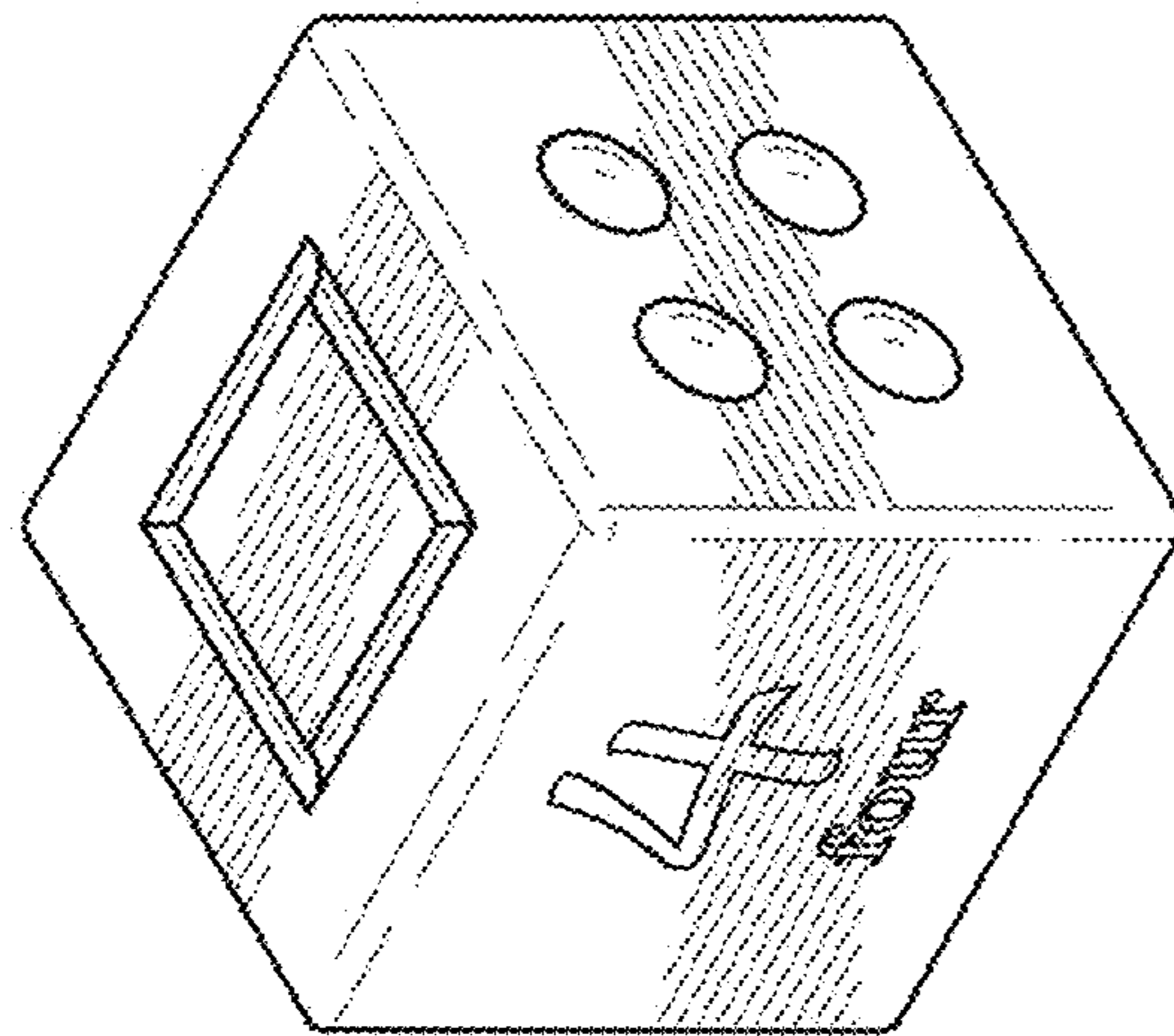

FIG. 41

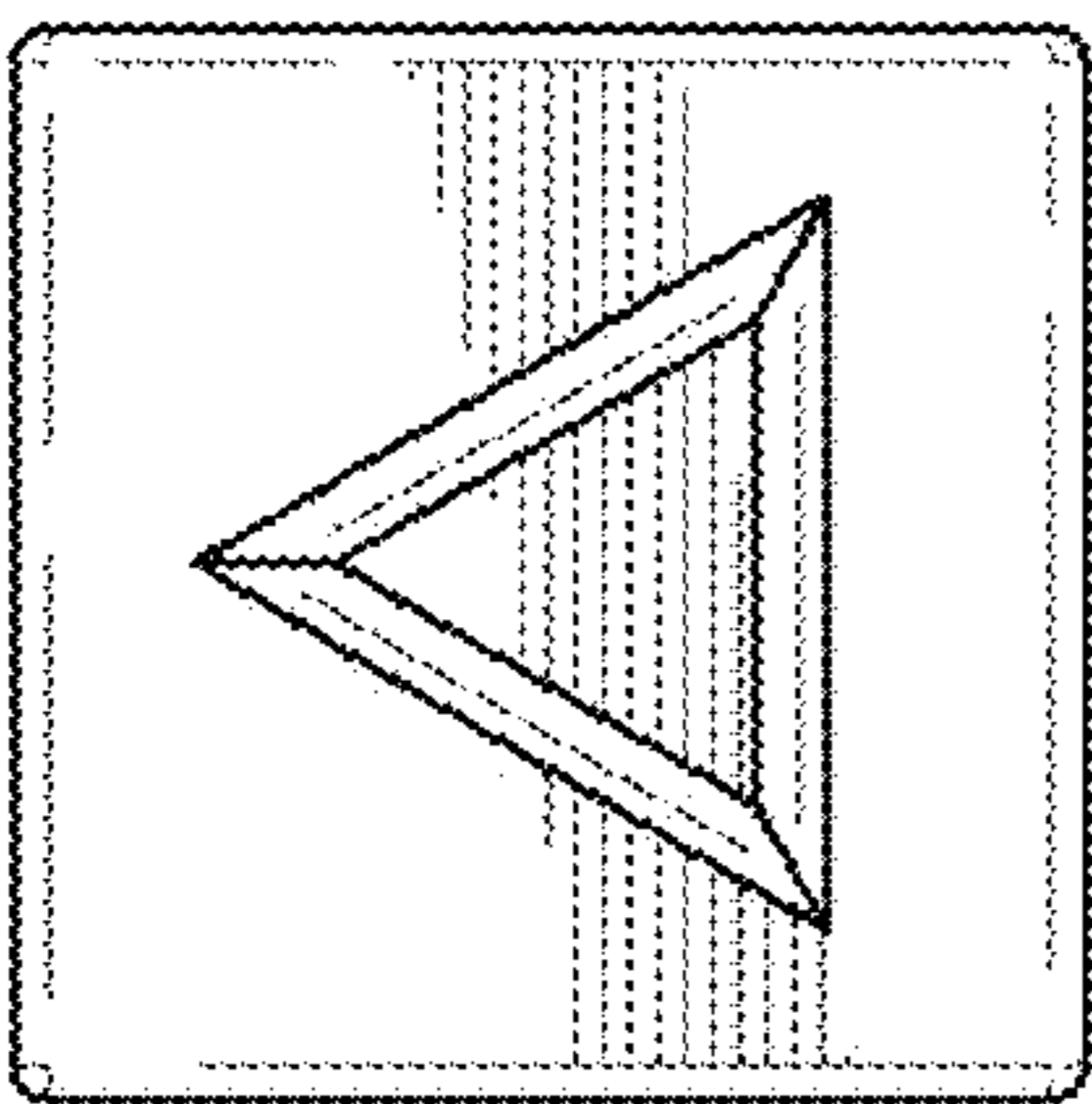

FIG. 43

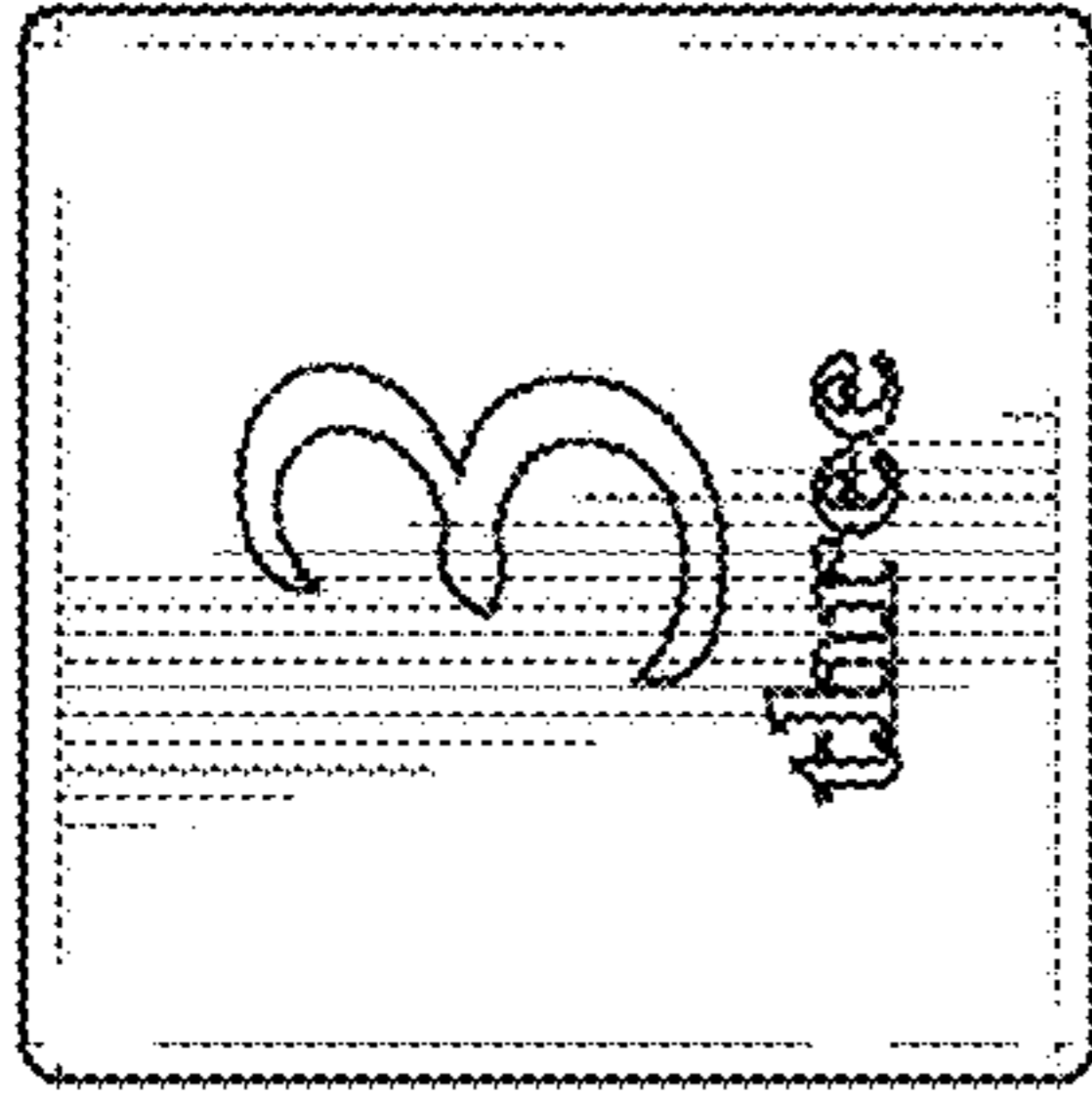

FIG. 44

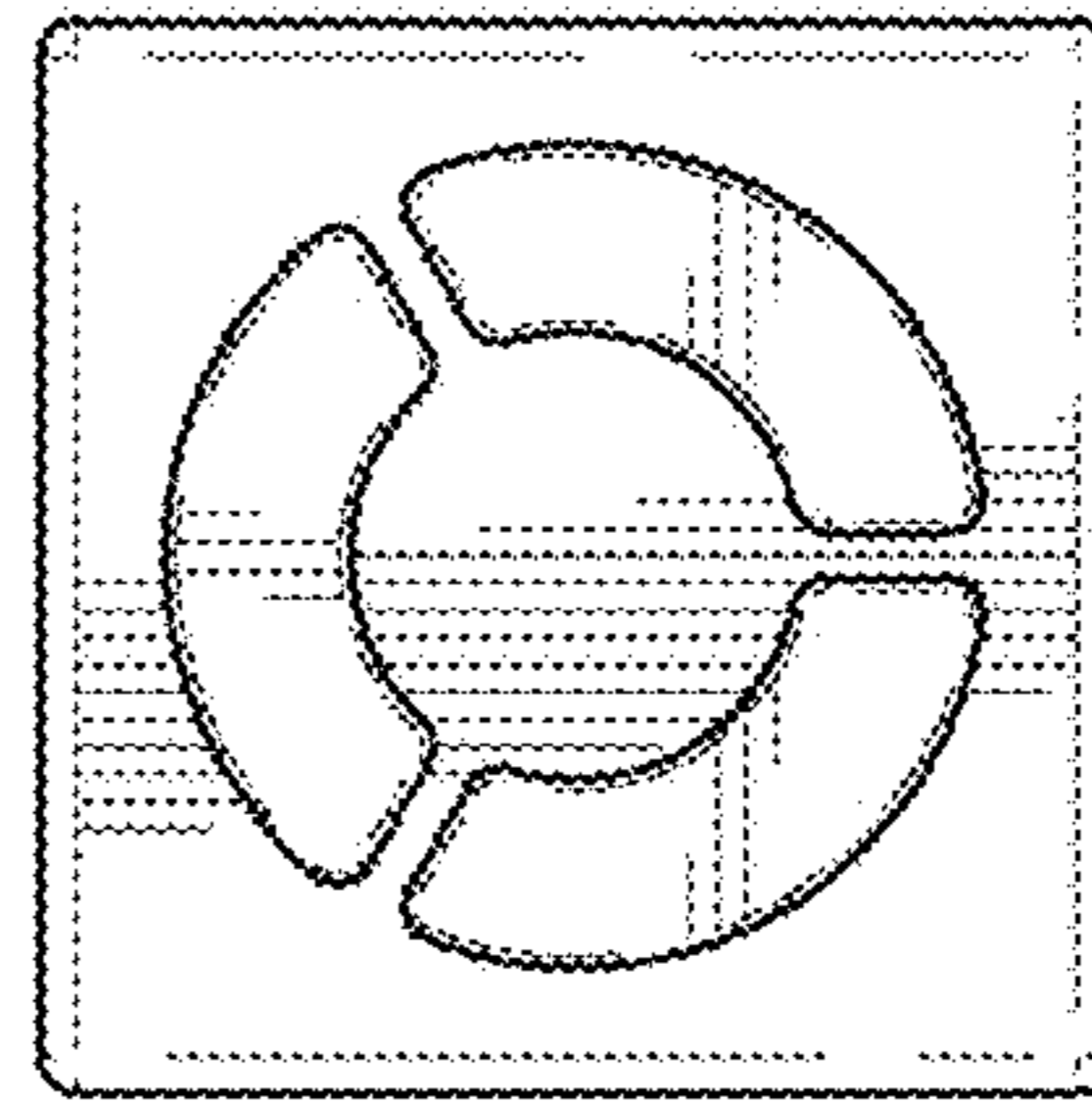

FIG. 45

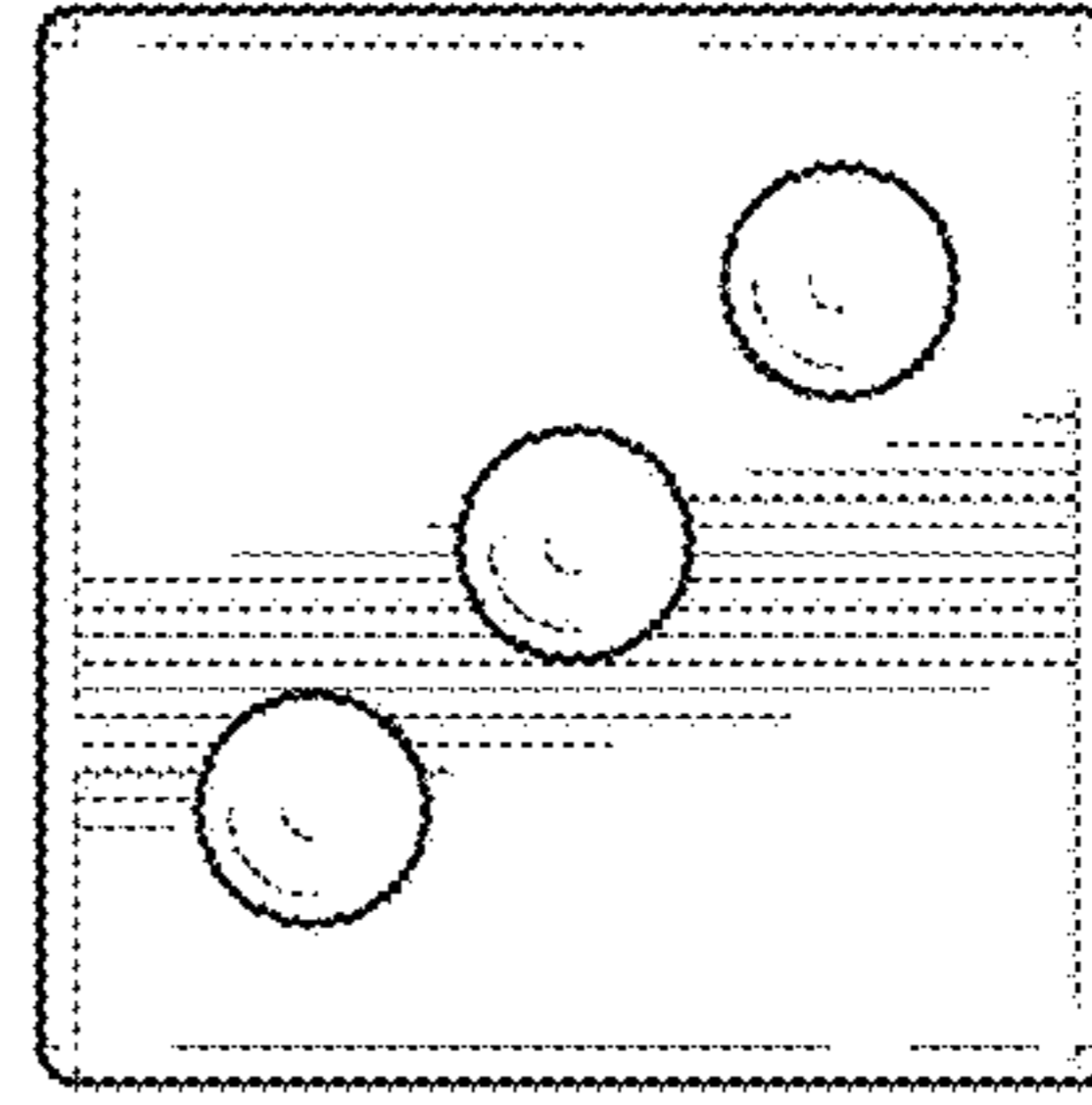

FIG. 46

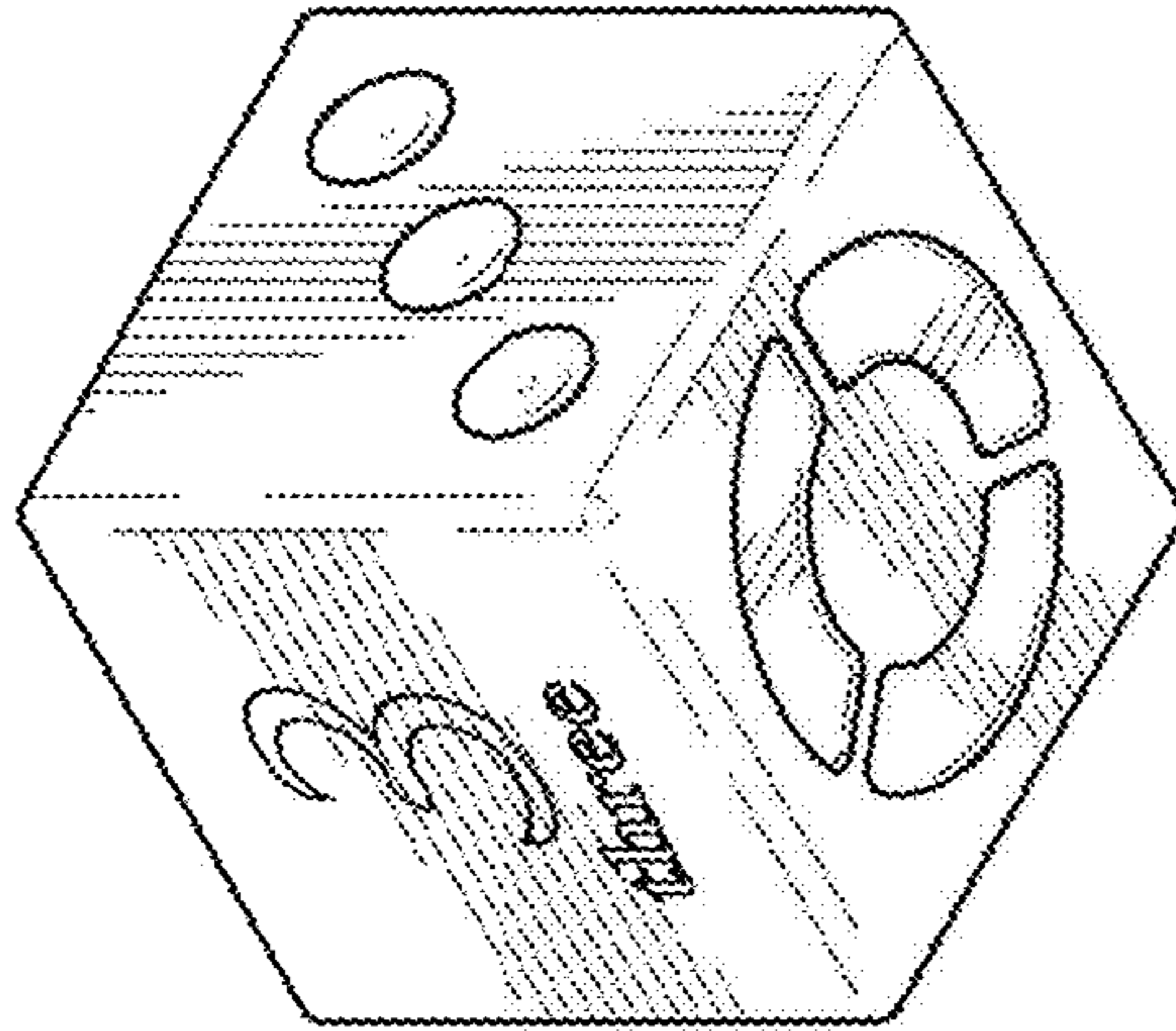

FIG. 48

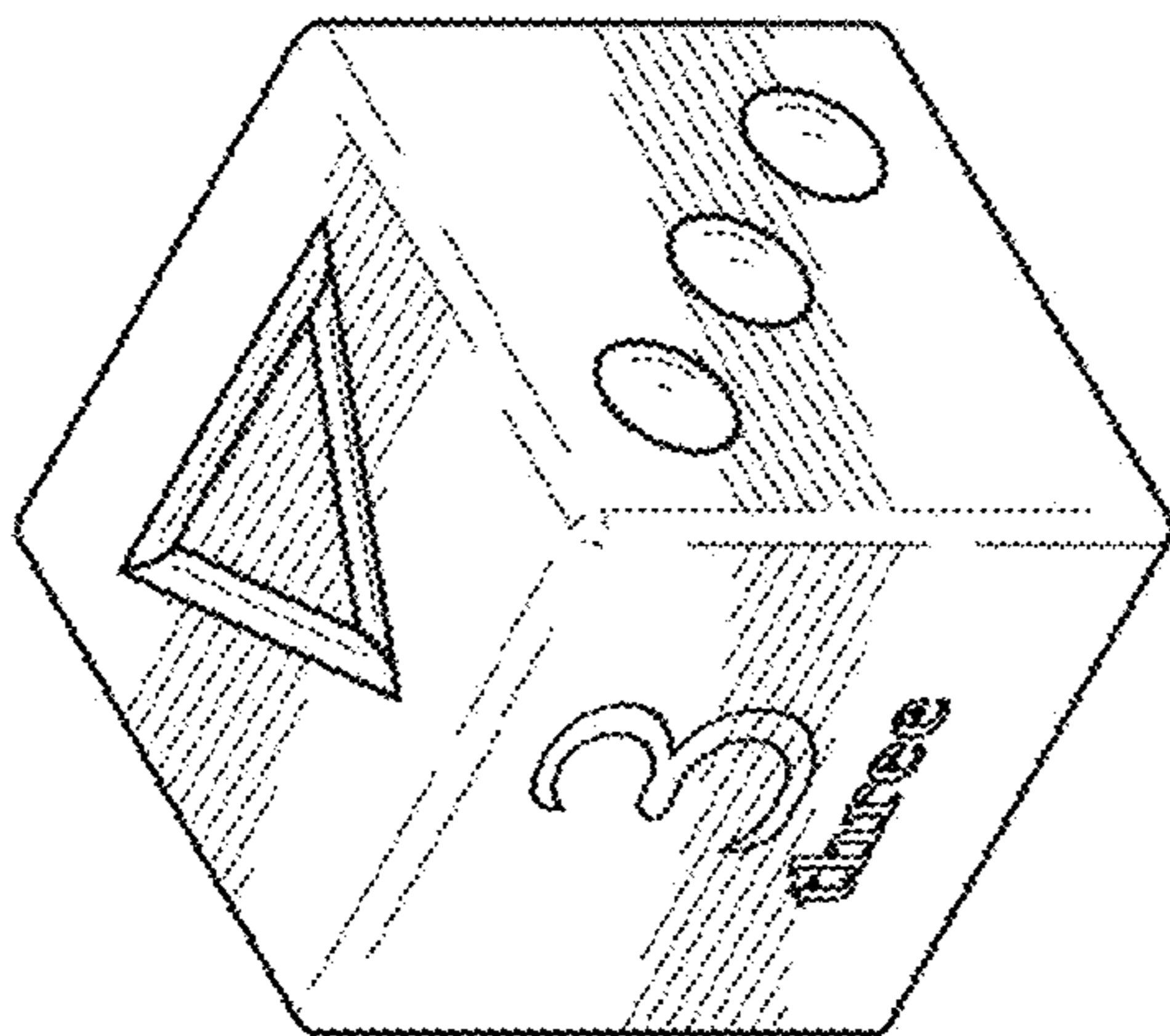

FIG. 47

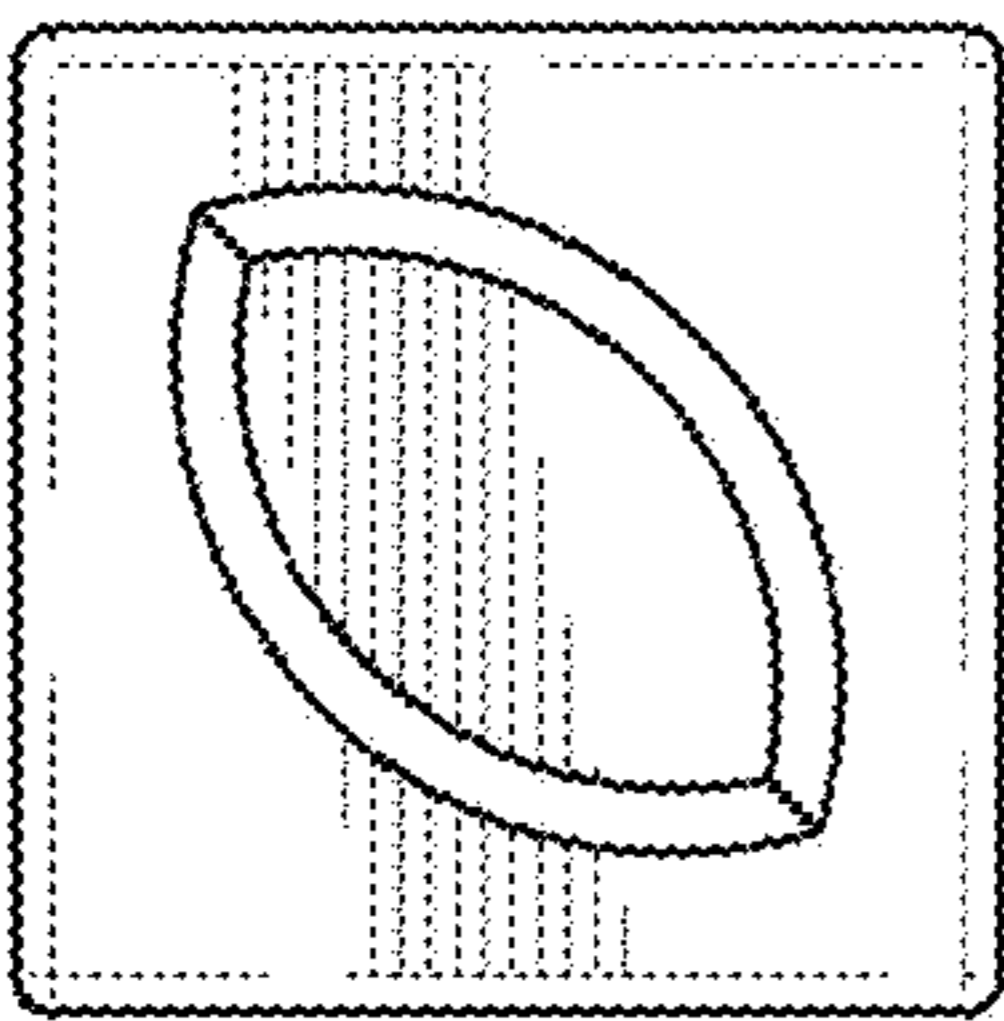

FIG. 49

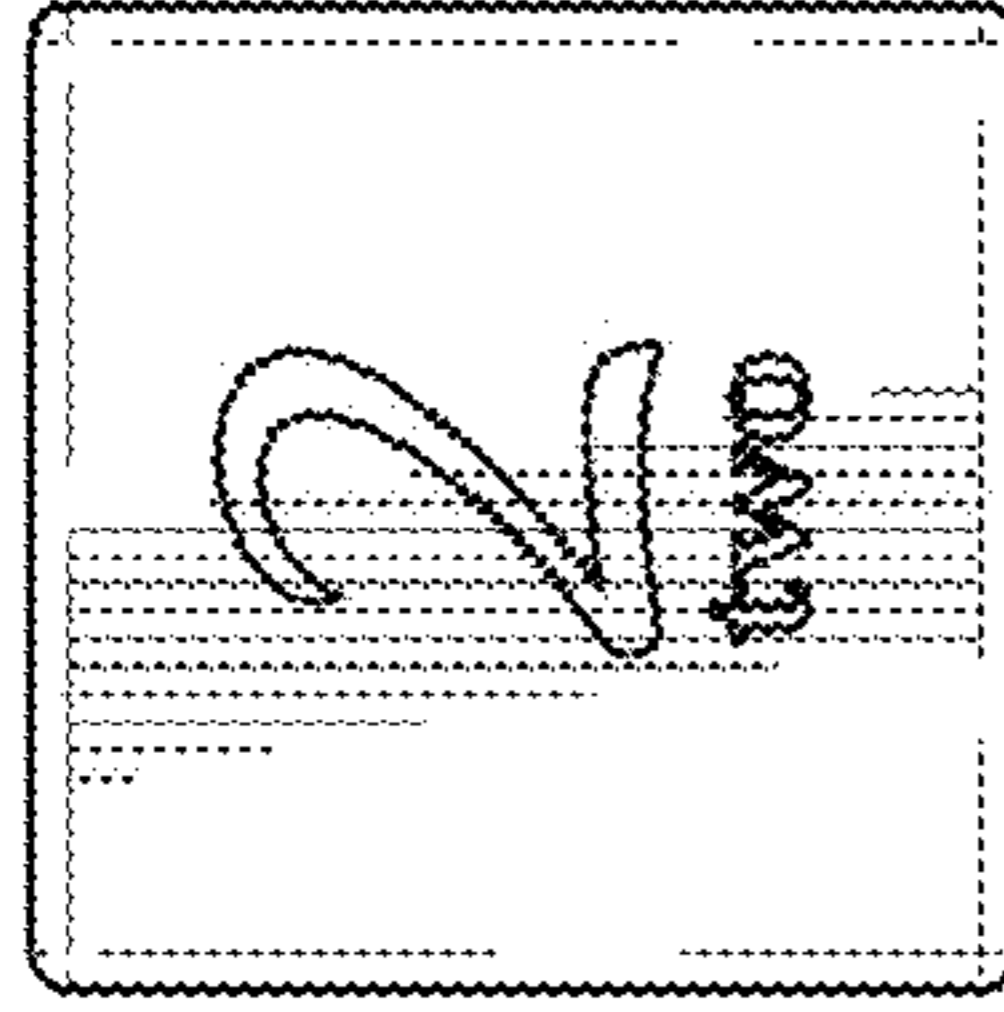

FIG. 50

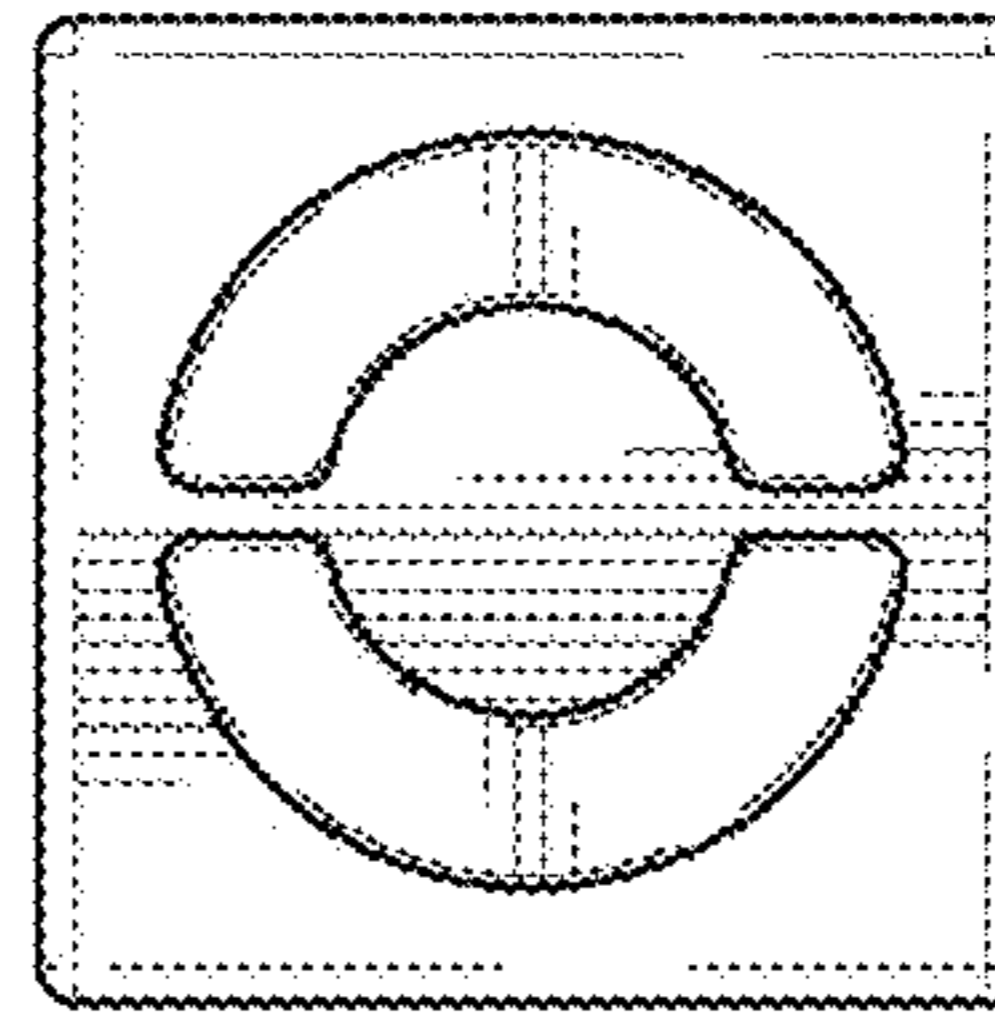

FIG. 51

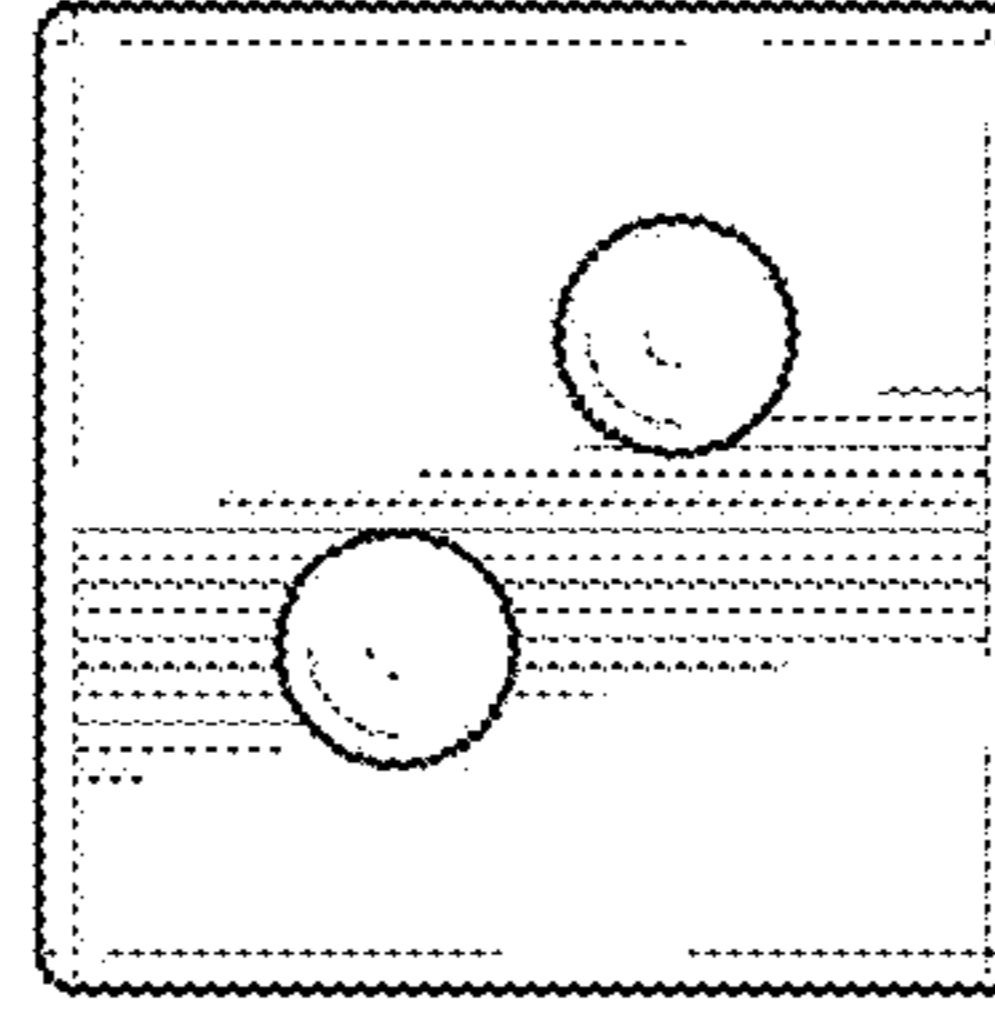

FIG. 52

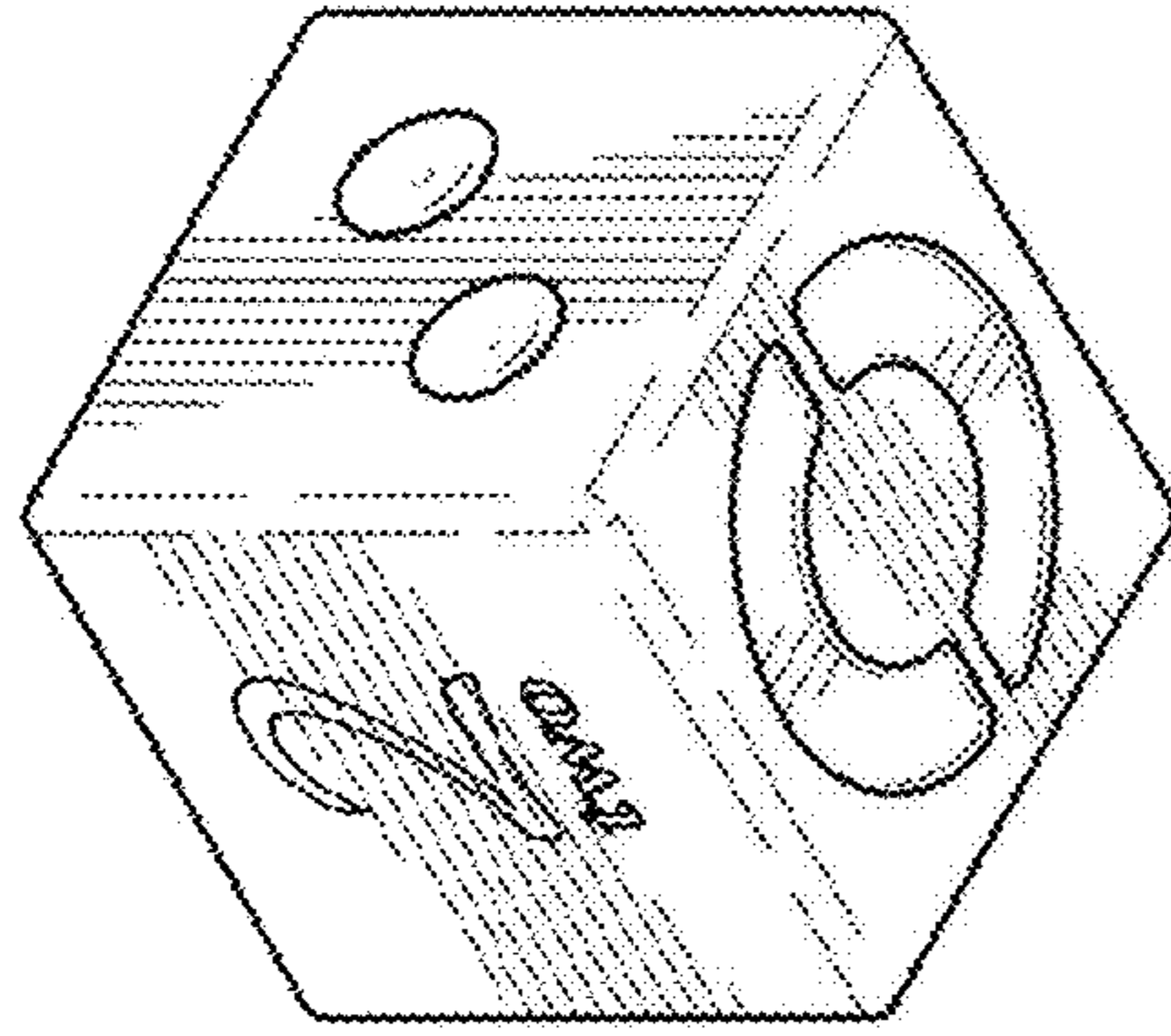

FIG. 54

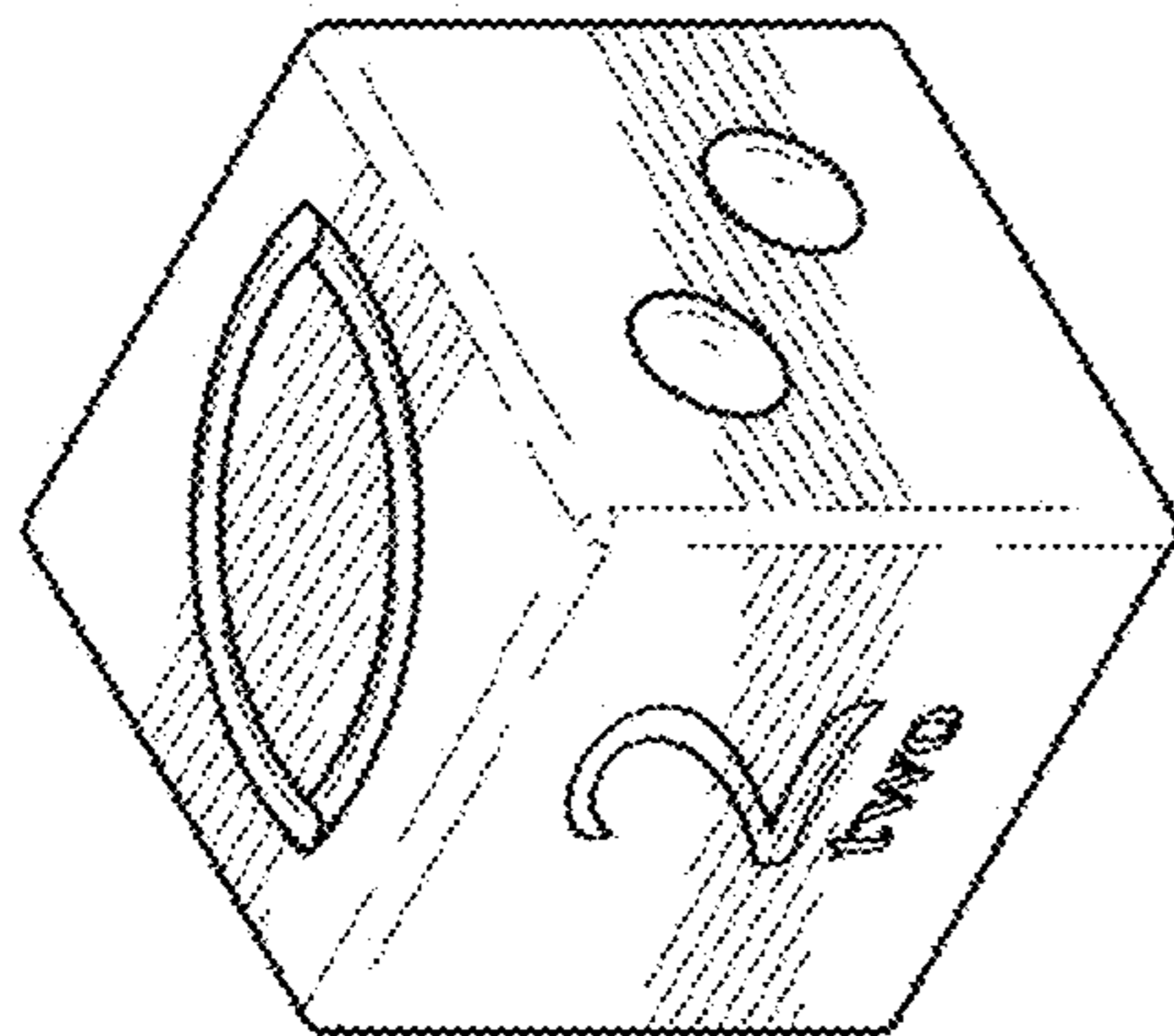

FIG. 53

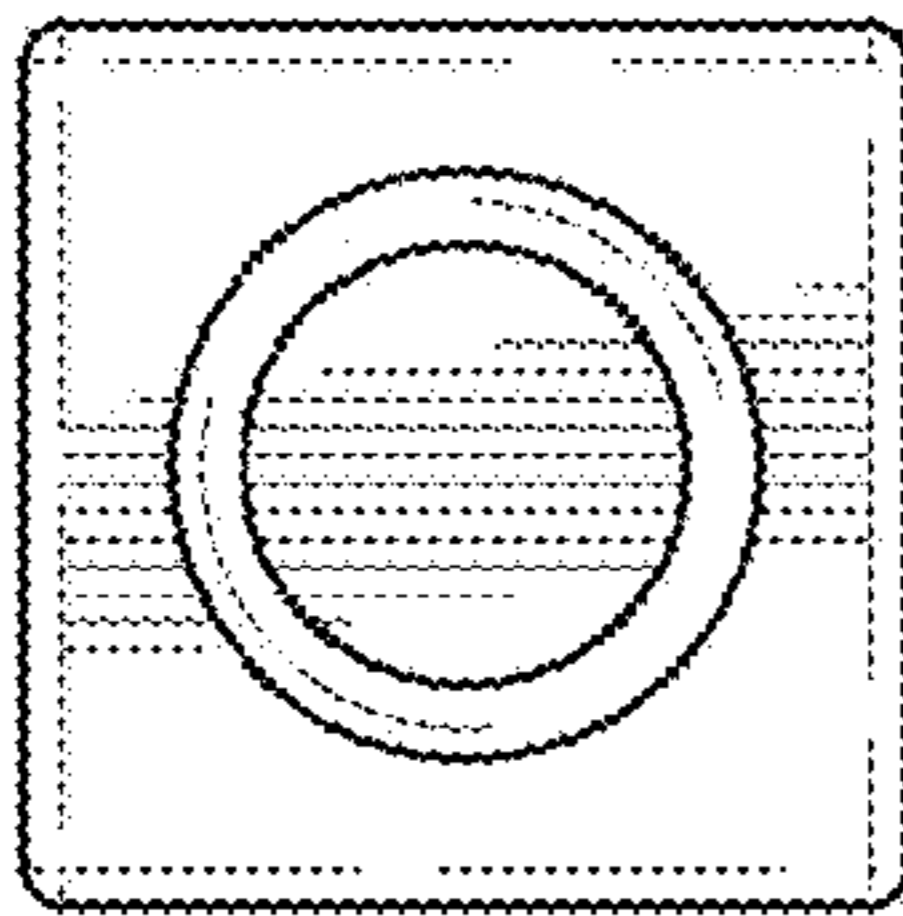

FIG. 55

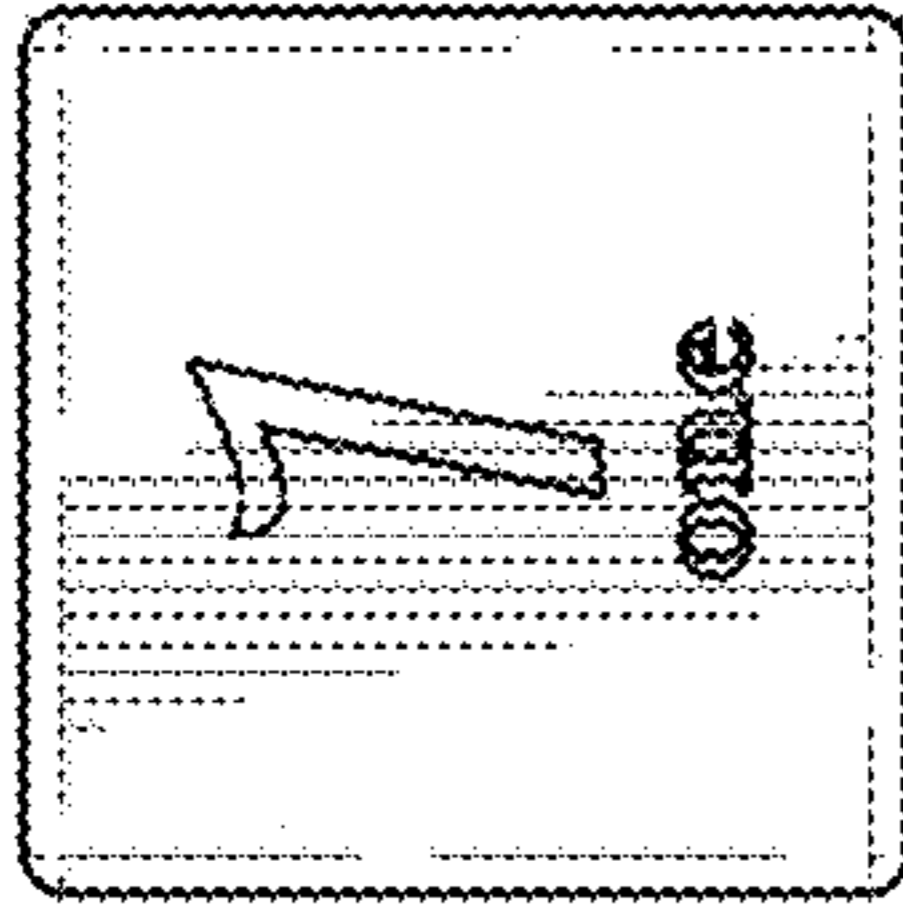

FIG. 56

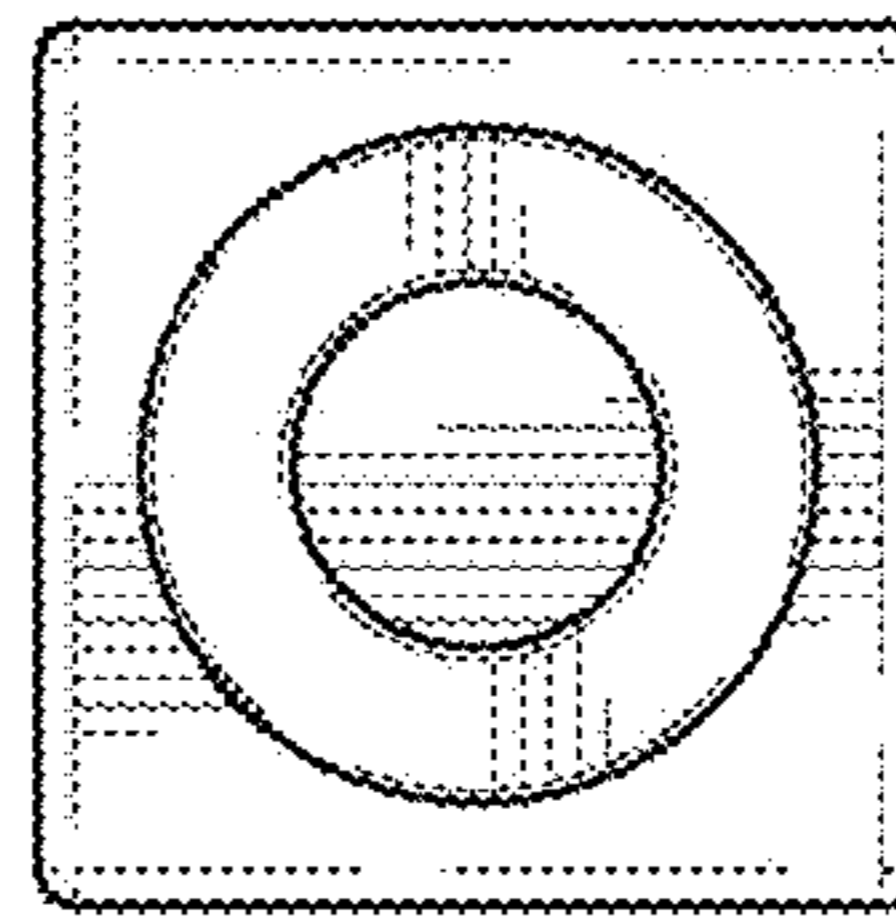

FIG. 57

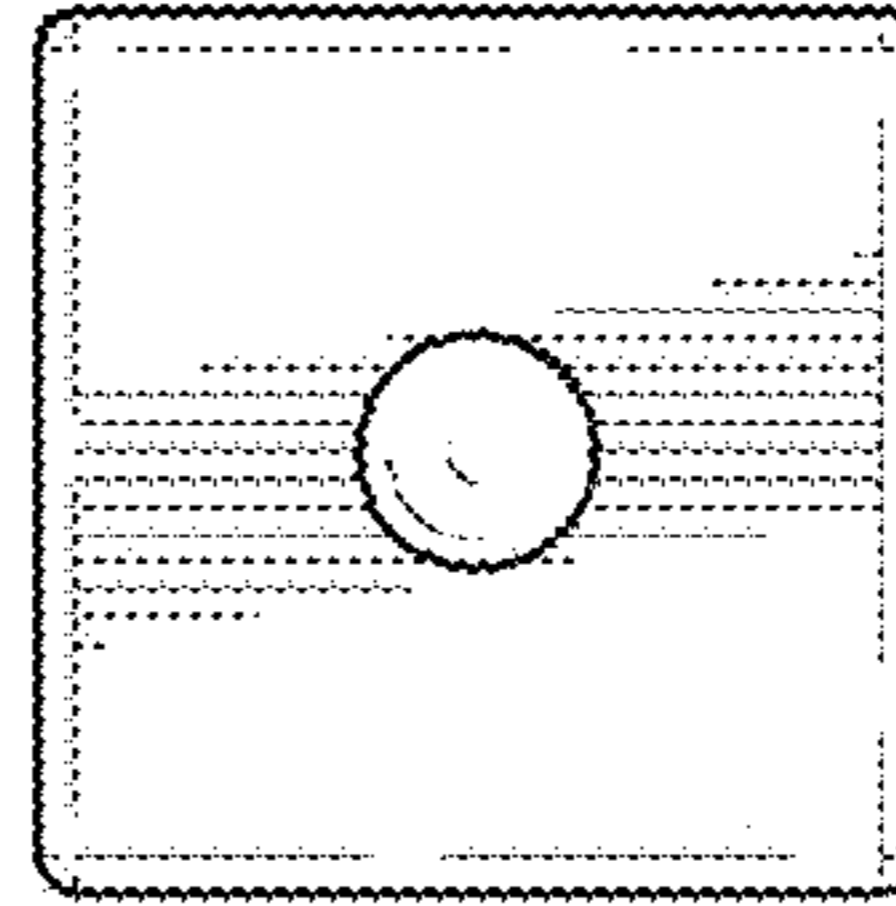

FIG. 58

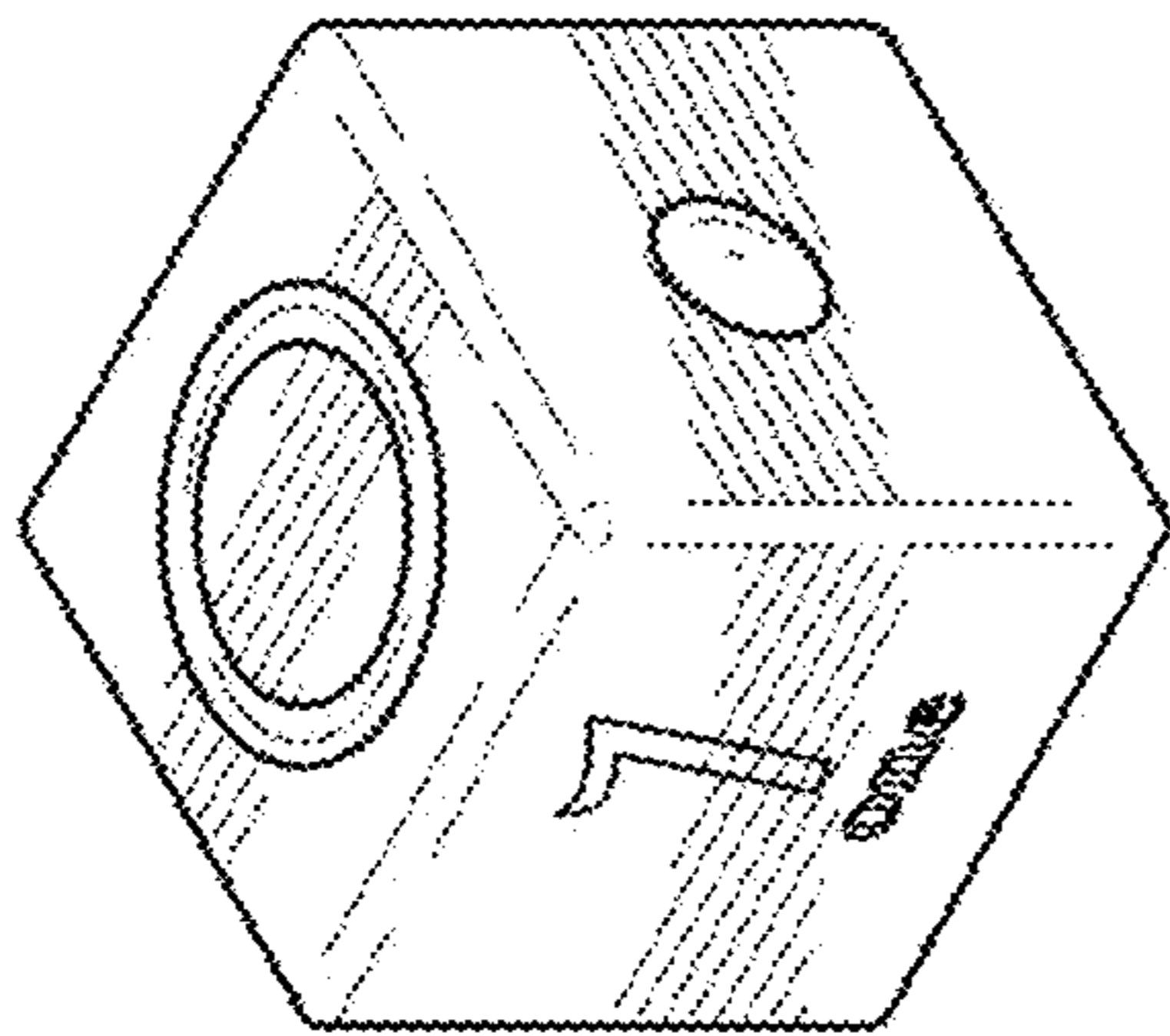
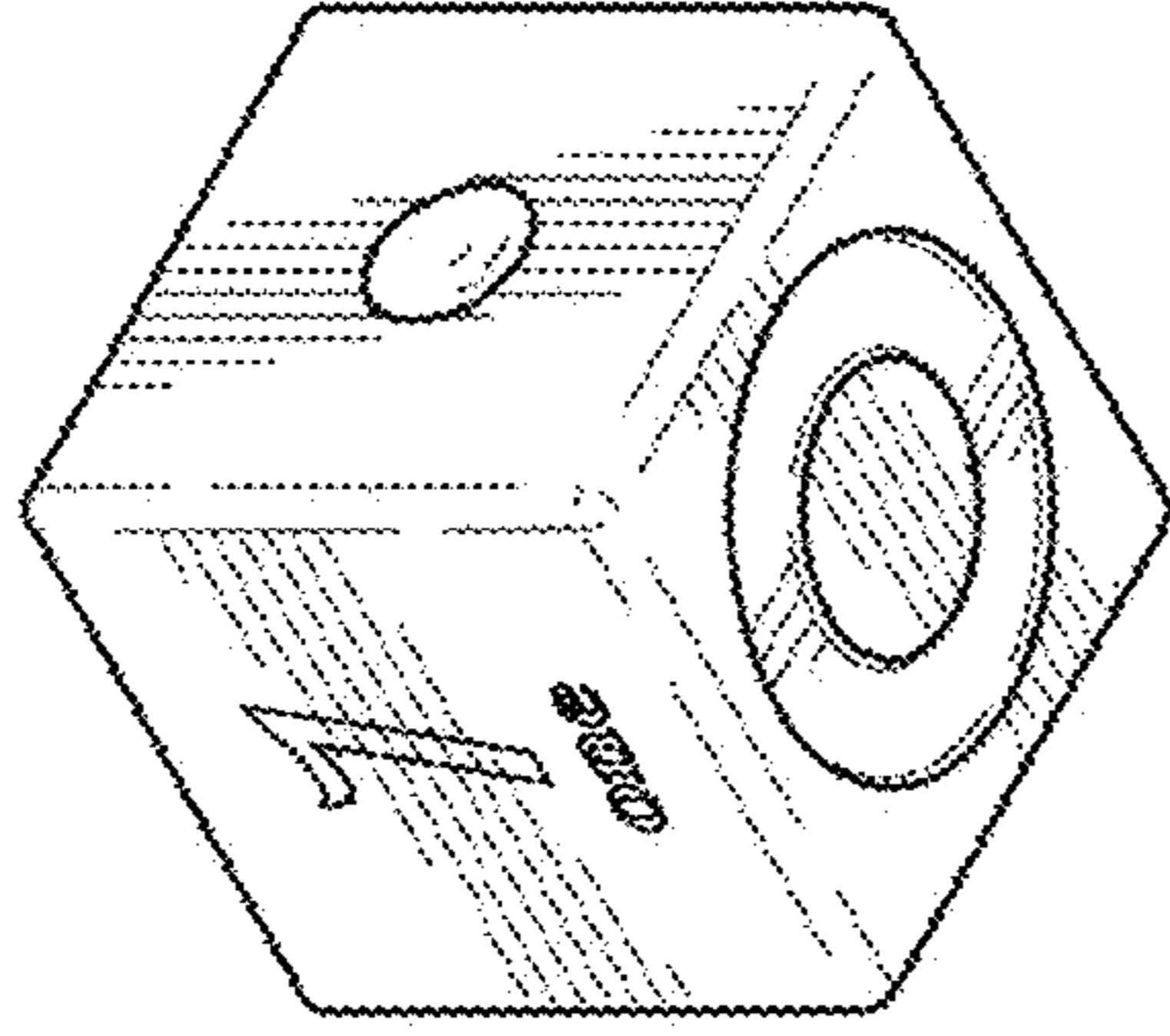

FIG. 60

FIG. 59

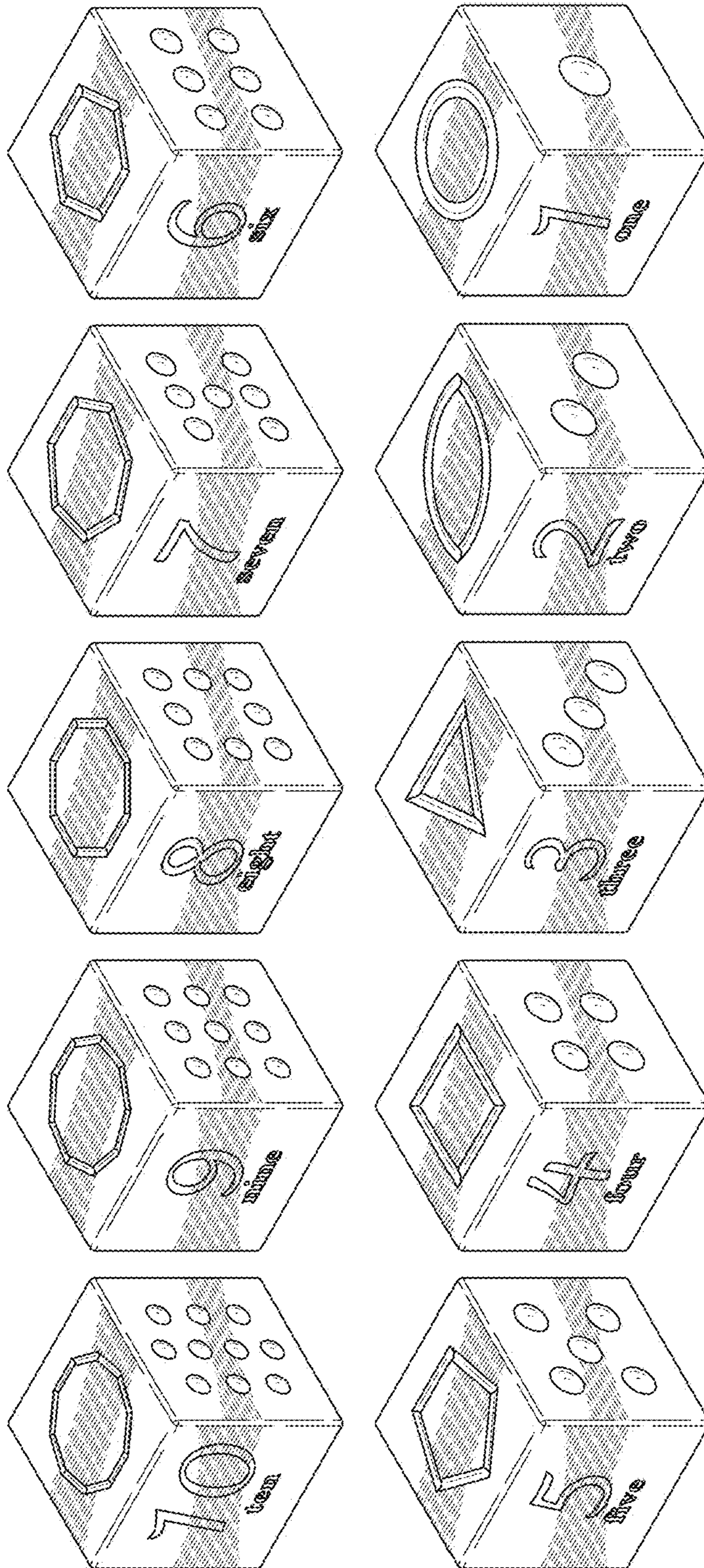

FIG. 61