



US00D825398S

(12) **United States Design Patent** (10) **Patent No.:** **US D825,398 S**
Nakagiri (45) **Date of Patent:** **** Aug. 14, 2018**

(54) **BICYCLE RACK FOR VEHICLE**
 (71) Applicant: **NIPPON SHARYO, LTD.**, Nagoya-shi, Aichi (JP)
 (72) Inventor: **Takahisa Nakagiri**, Toyokawa (JP)
 (73) Assignee: **NIPPON SHARYO, LTD.**, Nagoya-shi (JP)
 (**) Term: **15 Years**

6,331,094 B1 * 12/2001 Burrows B60P 3/077
 410/3
 D491,514 S * 6/2004 Thompson D12/408
 D491,515 S * 6/2004 Thompson D12/408
 D491,877 S * 6/2004 Thompson D12/408
 D504,362 S * 4/2005 Thompson D12/115
 D632,228 S * 2/2011 Marin D12/115
 D663,675 S * 7/2012 Sautter D12/408
 D669,415 S * 10/2012 Murray D12/408
 D715,856 S * 10/2014 Lozano D19/34.1
 D719,901 S * 12/2014 Krusinski D12/408
 D761,701 S * 7/2016 Jobe D12/115

(Continued)

(21) Appl. No.: **29/605,206**
 (22) Filed: **May 24, 2017**

Primary Examiner — George D. Kirschbaum
Assistant Examiner — Clese Moore, Jr.
 (74) *Attorney, Agent, or Firm* — Oliff PLC

(30) **Foreign Application Priority Data**
 Nov. 29, 2016 (JP) 2016-025868
 (51) **LOC (11) Cl.** **12-11**
 (52) **U.S. Cl.**
 USPC **D12/115**
 (58) **Field of Classification Search**
 USPC D12/115, 120, 402, 406, 407, 408
 CPC .. B60R 9/10; B60R 9/06; B60R 9/048; B60R 9/045
 See application file for complete search history.

(57) **CLAIM**

The ornamental design for a bicycle rack for vehicle, as shown and described.

DESCRIPTION

FIG. 1 is a front view of a bicycle rack for vehicle;
 FIG. 2 is a rear view thereof;
 FIG. 3 is a left-side view thereof;
 FIG. 4 is a right-side view thereof;
 FIG. 5 is a top view thereof;
 FIG. 6 is a bottom view thereof;
 FIG. 7 is a sectional view thereof taken along 7-7 in FIG. 1;
 FIG. 8 is a sectional view thereof taken along 8-8 in FIG. 1;
 FIG. 9 is a reference right-side view thereof showing the rack in a raised state;
 FIG. 10 is a reference right-side view thereof showing the rack in an open state; and,
 FIG. 11 is a reference right-side view thereof showing the rack in a state of use.
 The broken lines depict environmental subject matter only and form no part of the claimed design.

(56) **References Cited**
 U.S. PATENT DOCUMENTS
 D317,742 S * 6/1991 Miller 224/482
 5,244,133 A * 9/1993 Abbott B60R 9/10
 224/521
 D375,472 S * 11/1996 Slater D12/120
 5,833,074 A * 11/1998 Phillips B60R 9/10
 211/21
 D412,482 S * 8/1999 Chen D12/408
 5,996,870 A * 12/1999 Shaver B60R 9/06
 224/324
 D430,532 S * 9/2000 Frazier D12/407
 D431,523 S * 10/2000 Smith D12/408

1 Claim, 10 Drawing Sheets

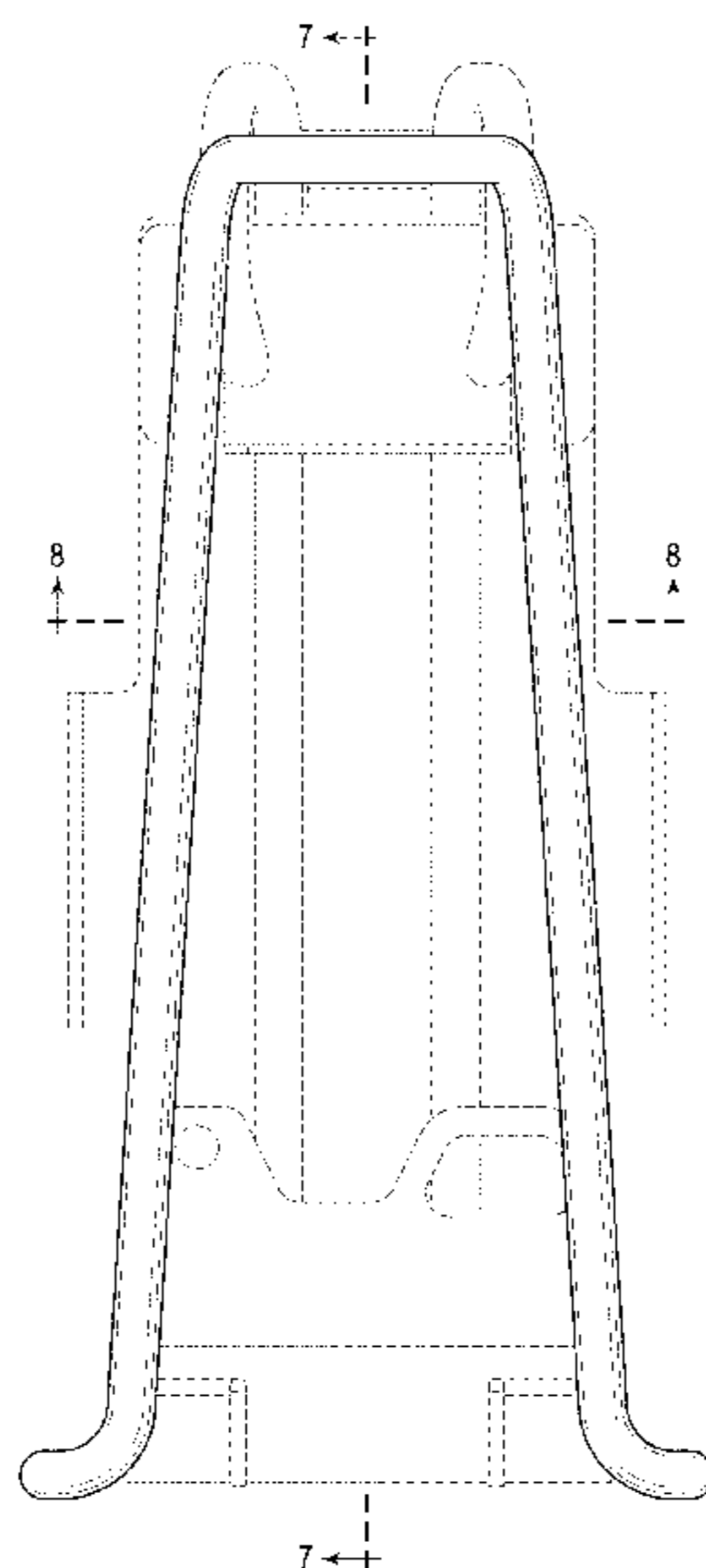

(56)

References Cited

U.S. PATENT DOCUMENTS

2004/0118884 A1* 6/2004 Ford B60R 9/10
224/310
2006/0196906 A1* 9/2006 Gibson, Jr. B60P 3/075
224/403
2012/0118928 A1* 5/2012 Laws B60R 9/06
224/403
2012/0305425 A1* 12/2012 Waters B62J 19/00
206/335
2013/0200316 A1* 8/2013 VanValkenburgh B66F 15/00
254/131

* cited by examiner

FIG. 1

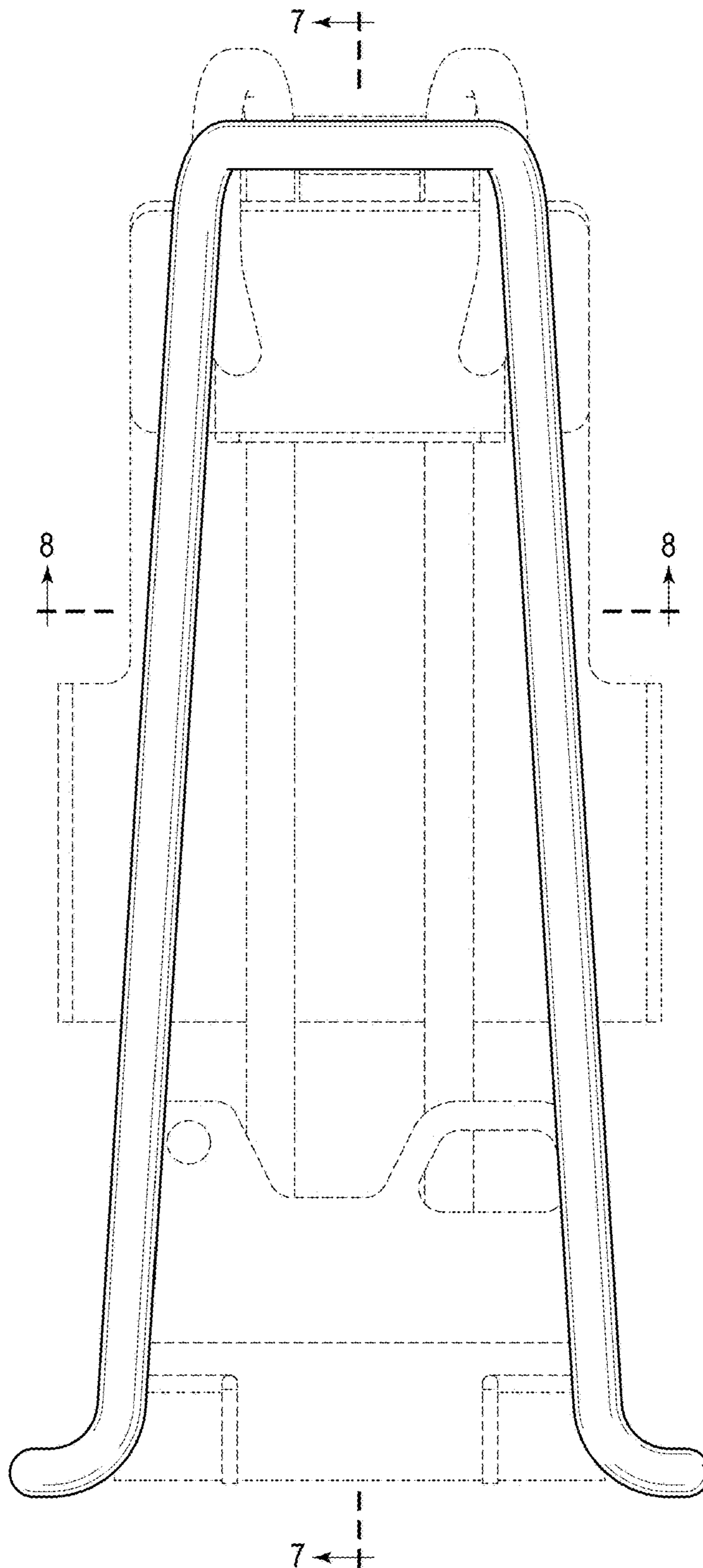

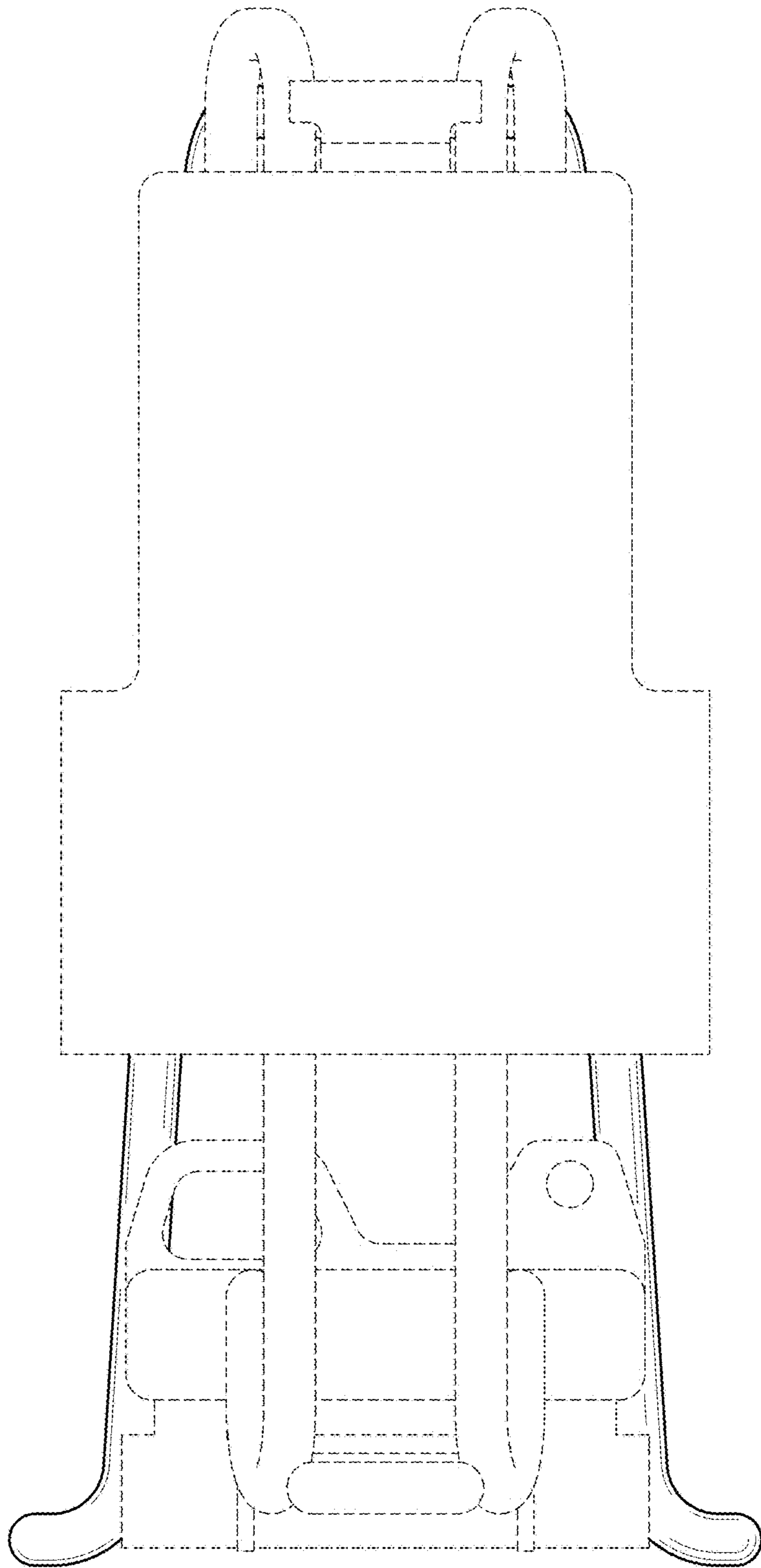

FIG. 2

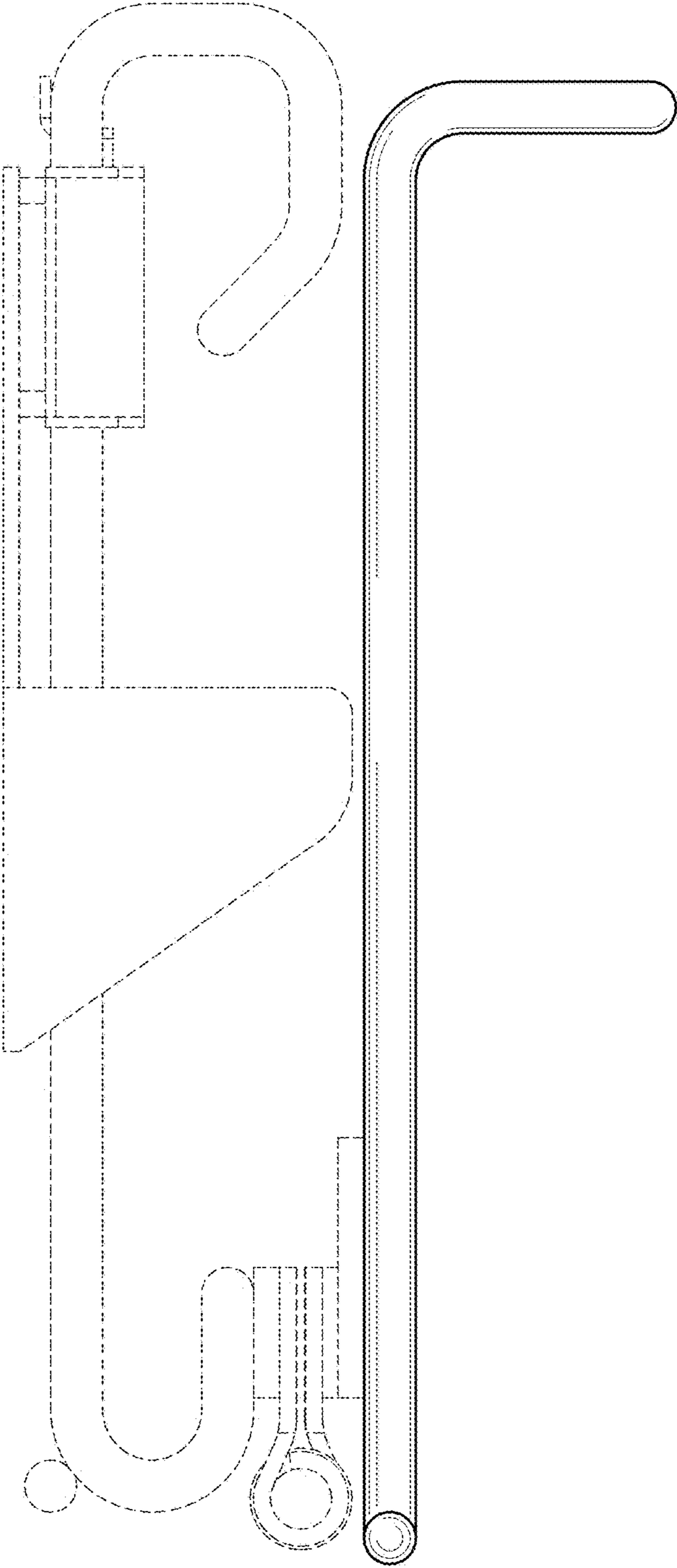

FIG. 3

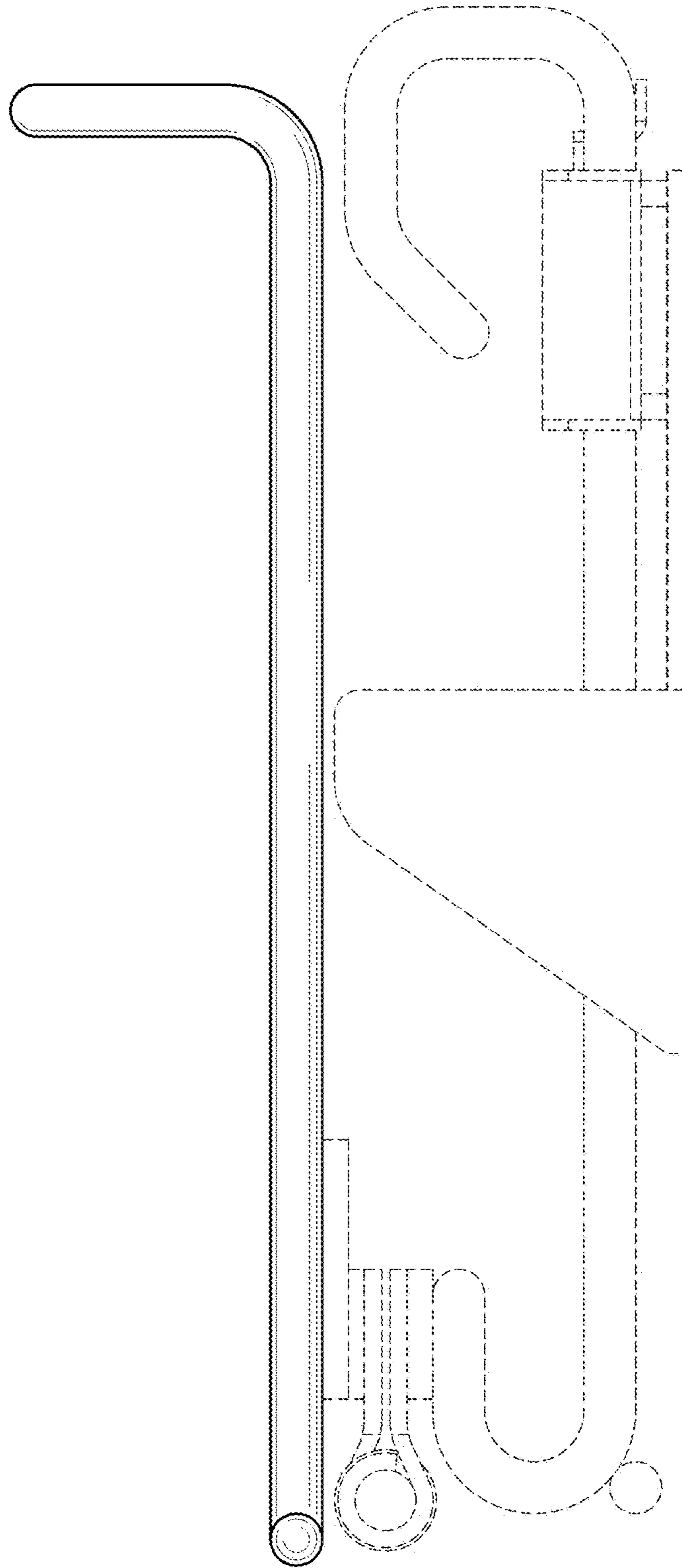

FIG. 4

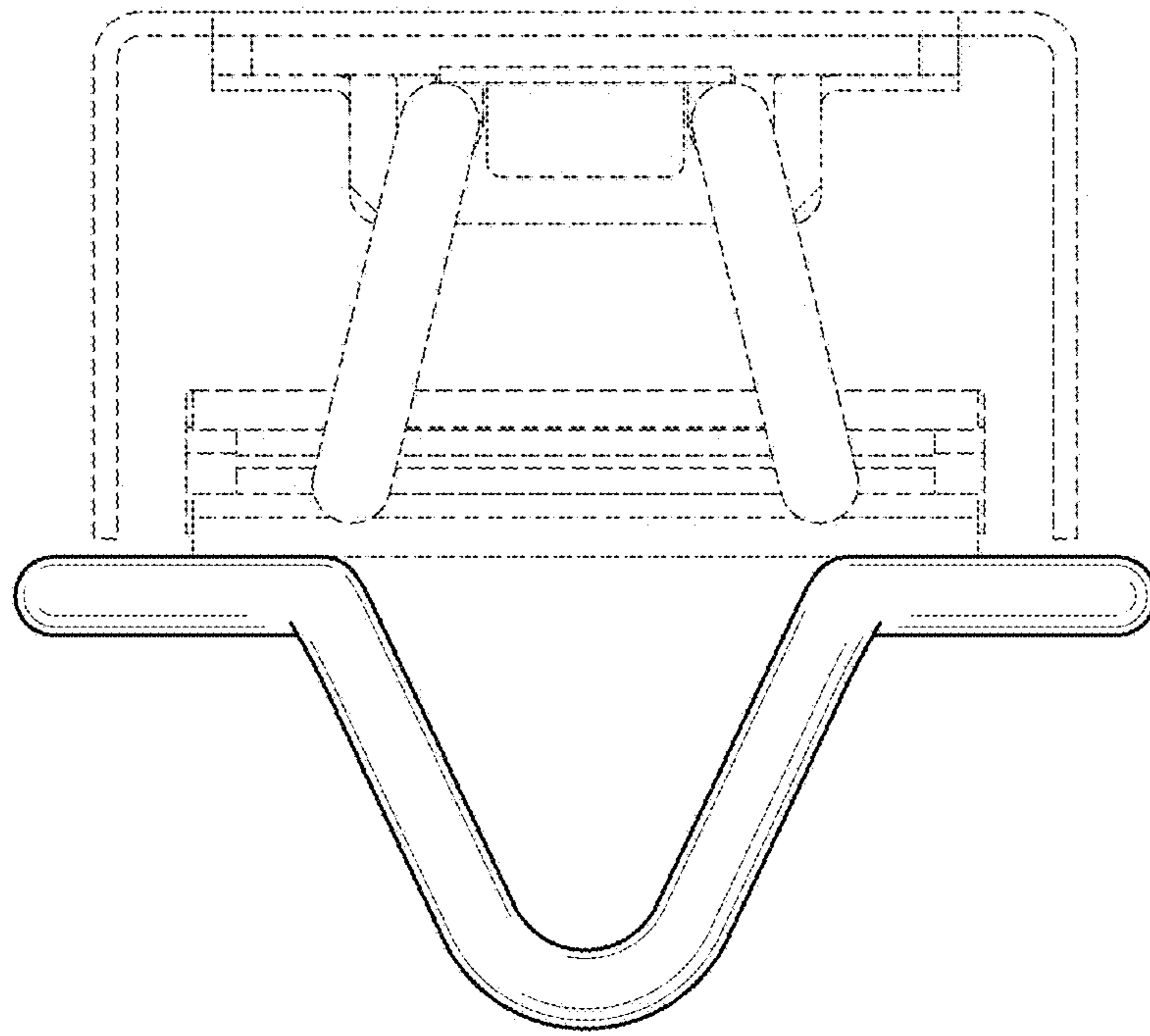

FIG. 5

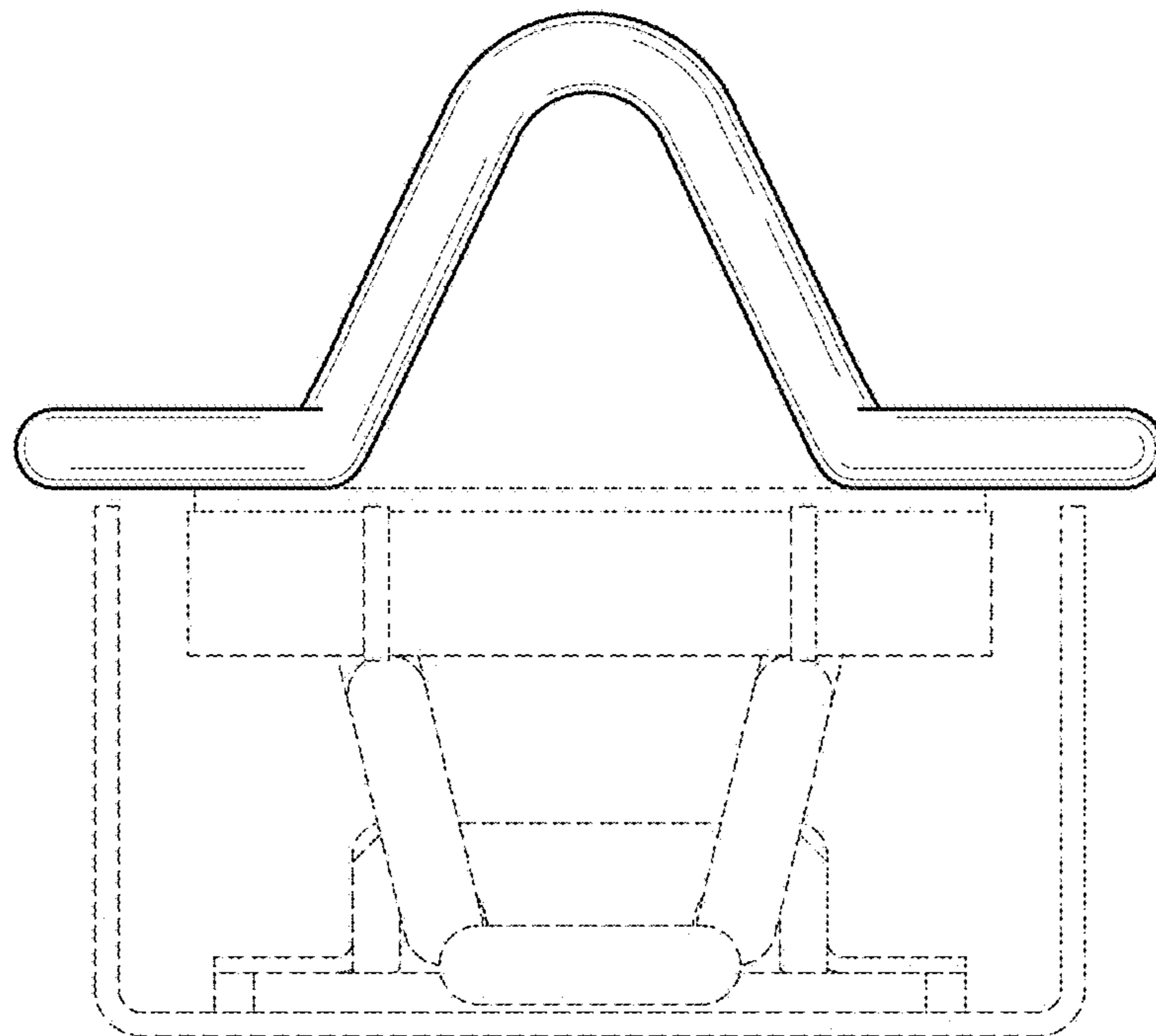

FIG. 6

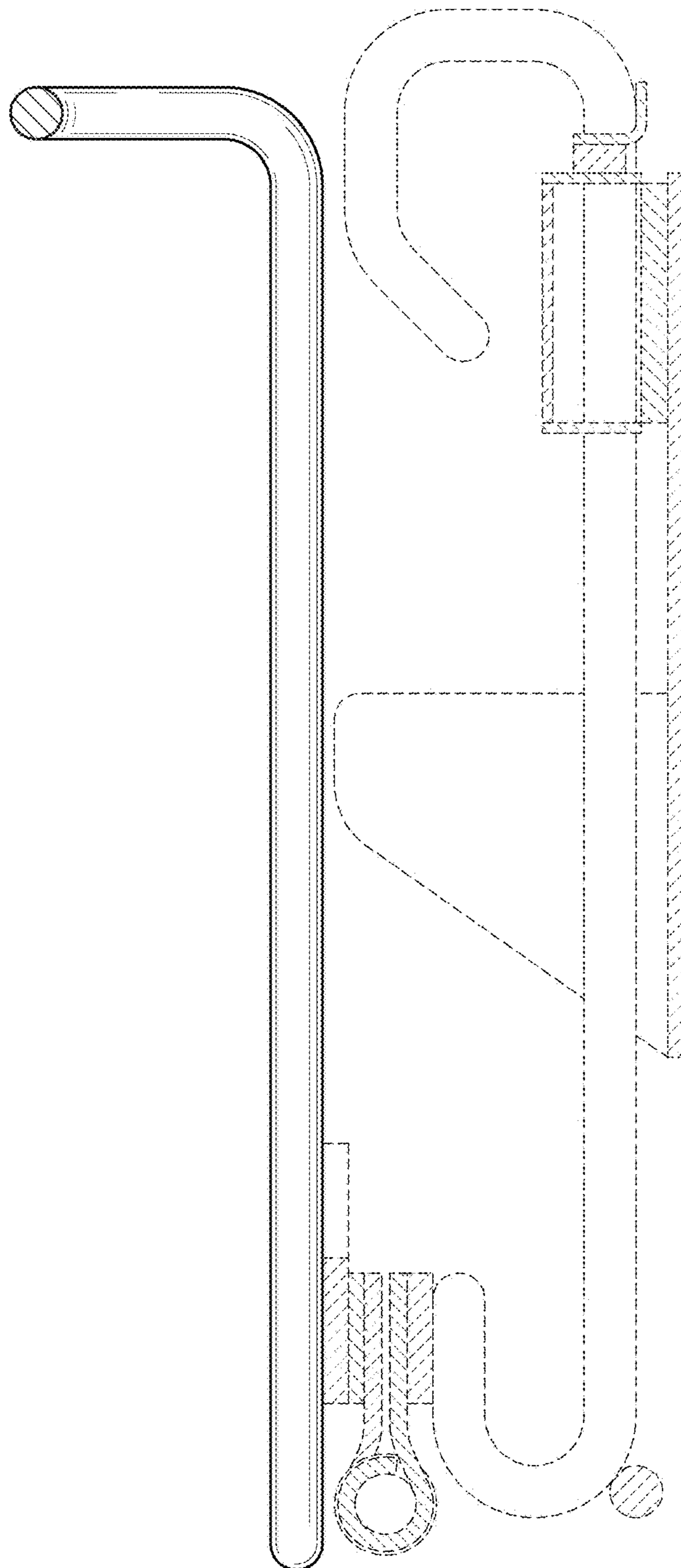

FIG. 7

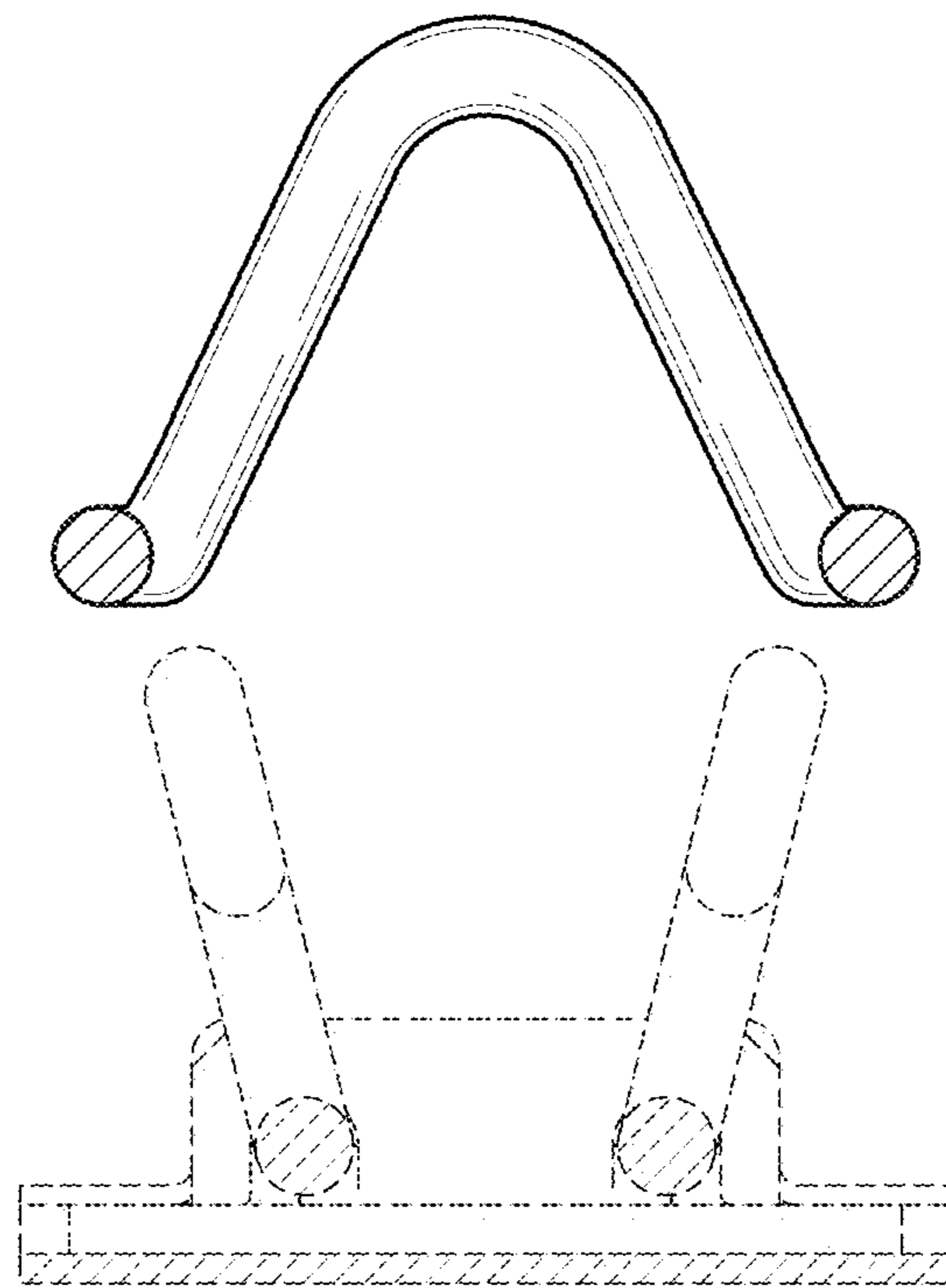

FIG. 8

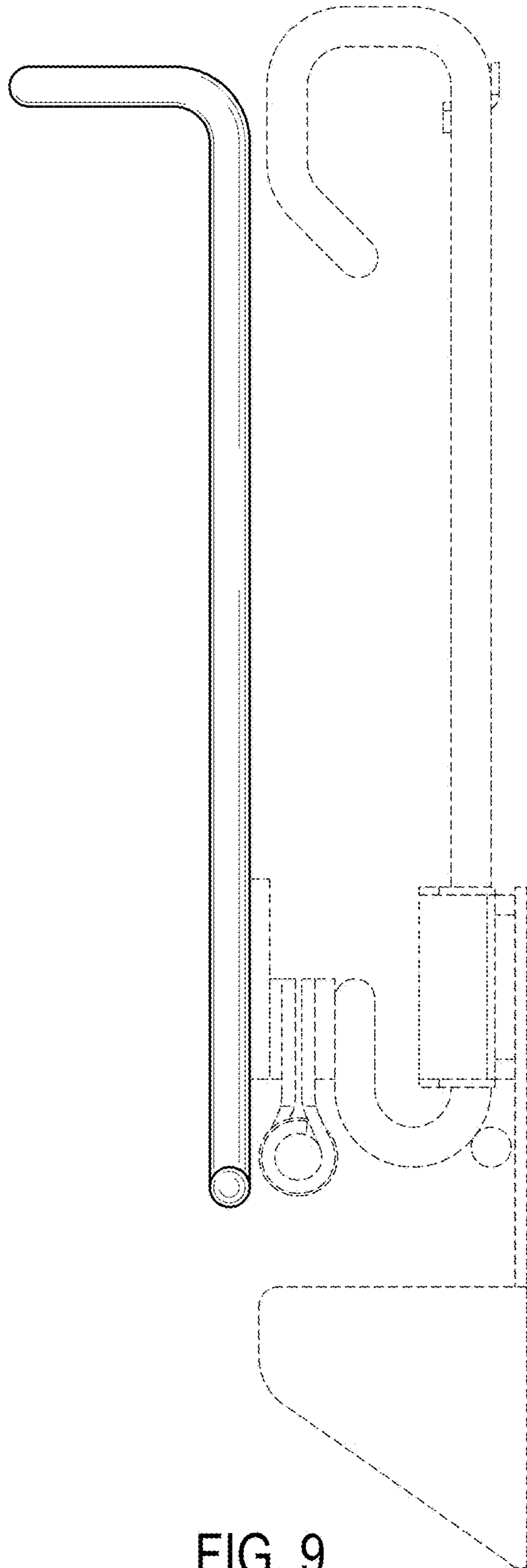

FIG. 9

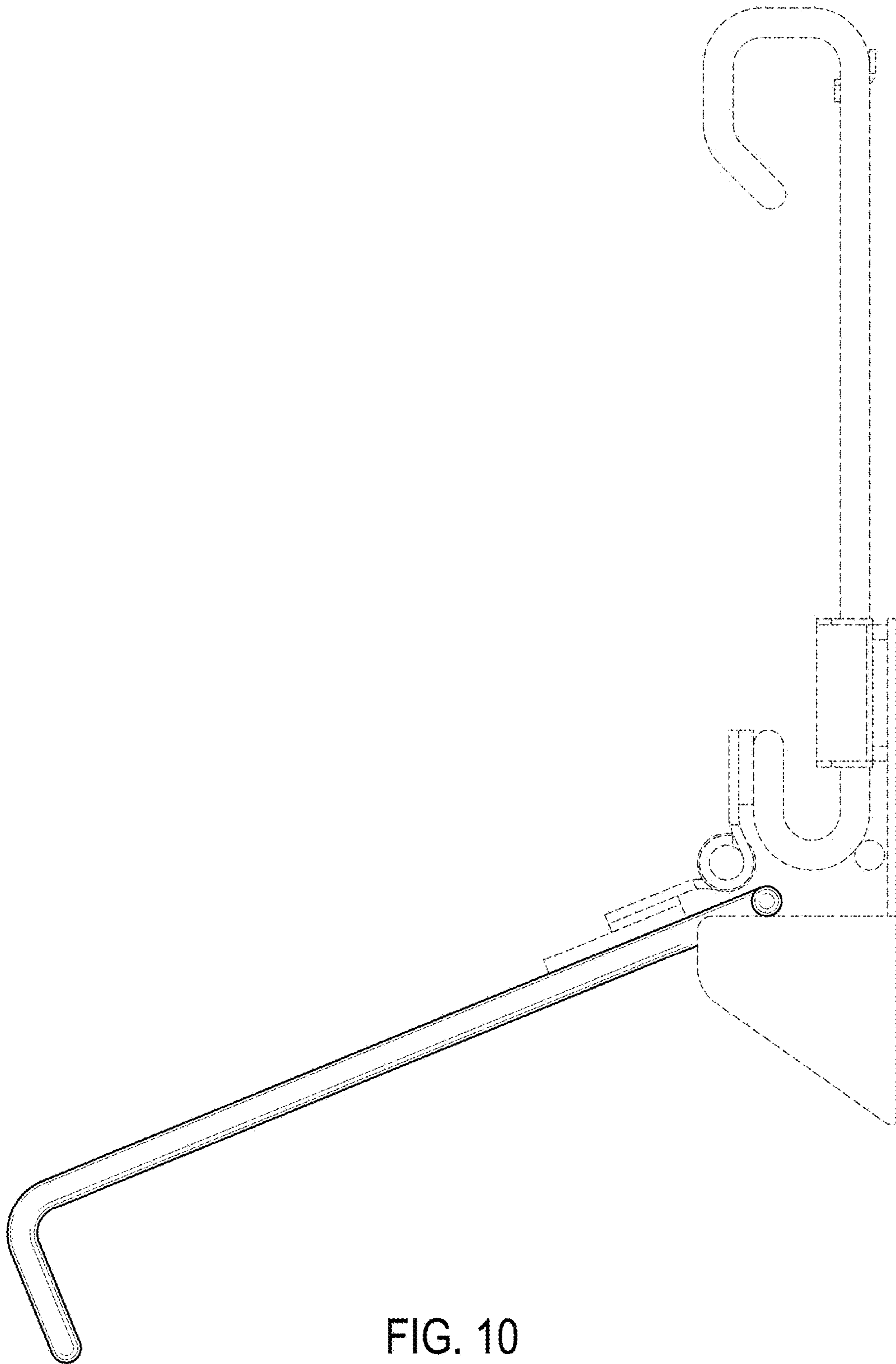

FIG. 10

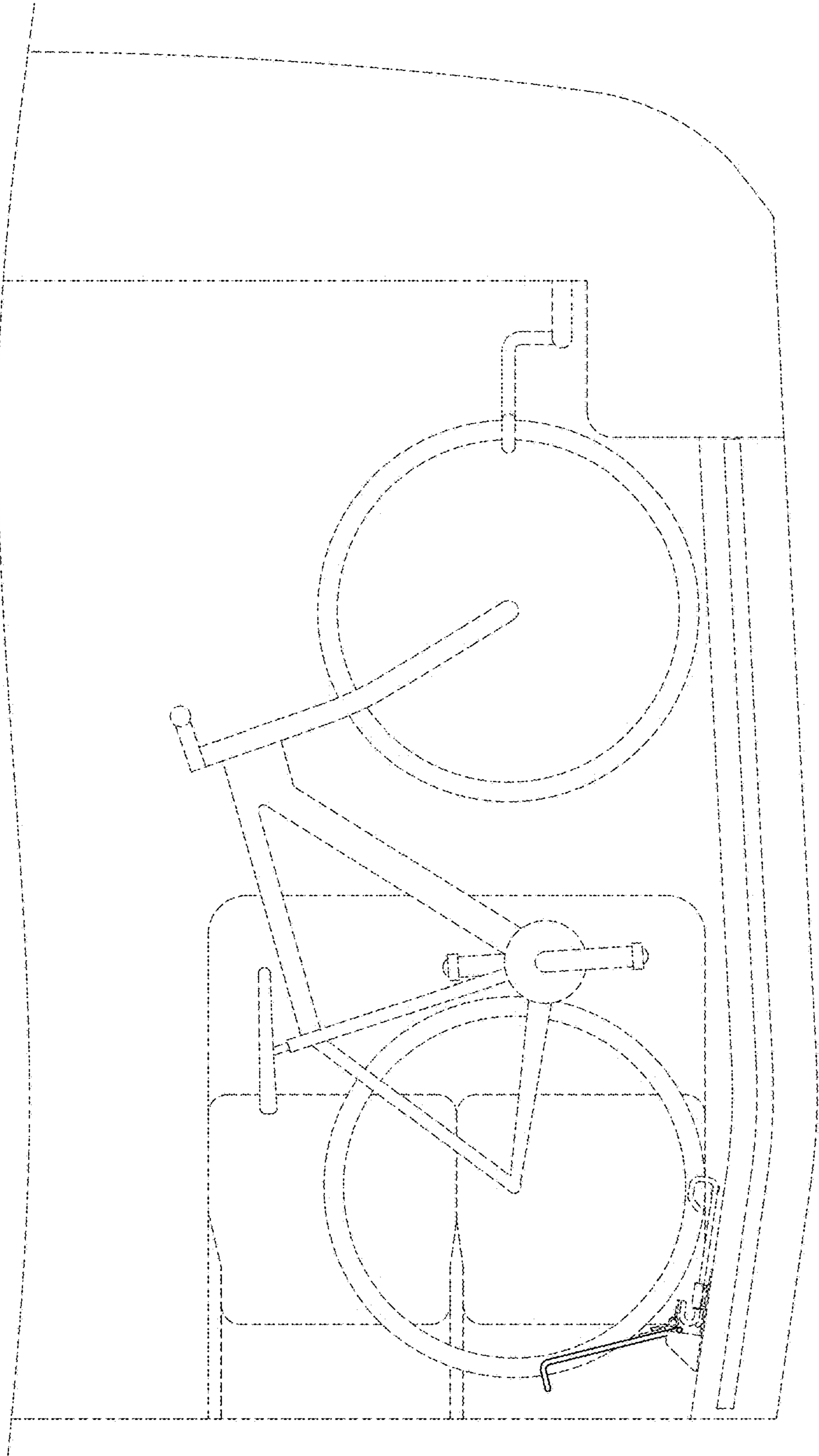

FIG. 11