



US00D825328S

(12) **United States Design Patent** (10) **Patent No.:** **US D825,328 S**  
**Simpson et al.** (45) **Date of Patent:** **\*\* Aug. 14, 2018**

(54) **CLOTHING PACKAGING**

- (71) Applicant: **THE MEN’S WEARHOUSE, INC.**,  
Houston, TX (US)
- (72) Inventors: **Doug Simpson**, Richmond, VA (US);  
**Rich Sullivan**, East Norriton, PA (US);  
**Tim Owen**, Norcross, GA (US)
- (73) Assignee: **The Men’s Wearhouse, Inc.**, Houston,  
TX (US)
- (\*\*) Term: **15 Years**
- (21) Appl. No.: **29/592,852**
- (22) Filed: **Feb. 2, 2017**
- (51) **LOC (11) Cl.** ..... **09-03**
- (52) **U.S. Cl.**  
USPC ..... **D9/432; D9/433; D9/423**
- (58) **Field of Classification Search**  
USPC ..... D9/414, 415, 416, 418, 432, 433, 715,  
D9/721; D7/541, 542, 553.3, 554.1,  
D7/554.3, 554.4, 555, 586, 587  
(Continued)

(56) **References Cited**

U.S. PATENT DOCUMENTS

- 2,233,799 A \* 3/1941 Seifer ..... B65D 5/46024  
229/117.22
- 2,758,774 A \* 8/1956 Grunert ..... B65D 5/3642  
206/493

(Continued)

*Primary Examiner* — Lauren R Calve

(74) *Attorney, Agent, or Firm* — Kilpatrick Townsend & Stockton LLP

(57) **CLAIM**

The ornamental design for a clothing packaging, as shown and described.

**DESCRIPTION**

FIG. 1 is a perspective view of a clothing packaging in a closed configuration showing our new design;

FIG. 2 is an exploded perspective view thereof shown in environmental use;  
 FIG. 3 is an exploded perspective view thereof shown in a second environmental use;  
 FIG. 4 is a perspective view thereof in an opened configuration;  
 FIG. 5 is a top view of a first component of the clothing packaging in a closed configuration shown without the second component for clarity of illustration;  
 FIG. 6 is a bottom view thereof;  
 FIG. 7 is a front view thereof;  
 FIG. 8 is a rear view thereof;  
 FIG. 9 is a left view thereof;  
 FIG. 10 is a right view thereof;  
 FIG. 11 is a perspective view of the first component of the clothing packaging in an opened configuration shown without the second component for clarity of illustration;  
 FIG. 12 is a top view of a second component of the clothing packaging in an unfolded configuration shown without the first component for clarity of illustration;  
 FIG. 13 is a side view thereof;  
 FIG. 14 is a top view of the second component of the clothing packaging in a first folded configuration shown without the first component for clarity of illustration;  
 FIG. 15 is a side view thereof;  
 FIG. 16 is a rear top right perspective view of the second component of the clothing packaging in a second folded configuration shown without the first component for clarity of illustration;  
 FIG. 17 is a front top left perspective view thereof;  
 FIG. 18 is a front view thereof;  
 FIG. 19 is a rear view thereof;  
 FIG. 20 is a left side view thereof, the right side view is a mirror image of the left side view;  
 FIG. 21 is a left side view of the second component of the clothing packaging in a third folded configuration, shown without the first component for clarity of illustration, the right side view is a mirror image of the left side view; and,  
 FIG. 22 is a second left side view thereof, shown in environmental use, the right side view is a mirror image of the left side view.  
 The broken lines shown represent unclaimed subject matter and form no part of the claimed design.

**1 Claim, 14 Drawing Sheets**

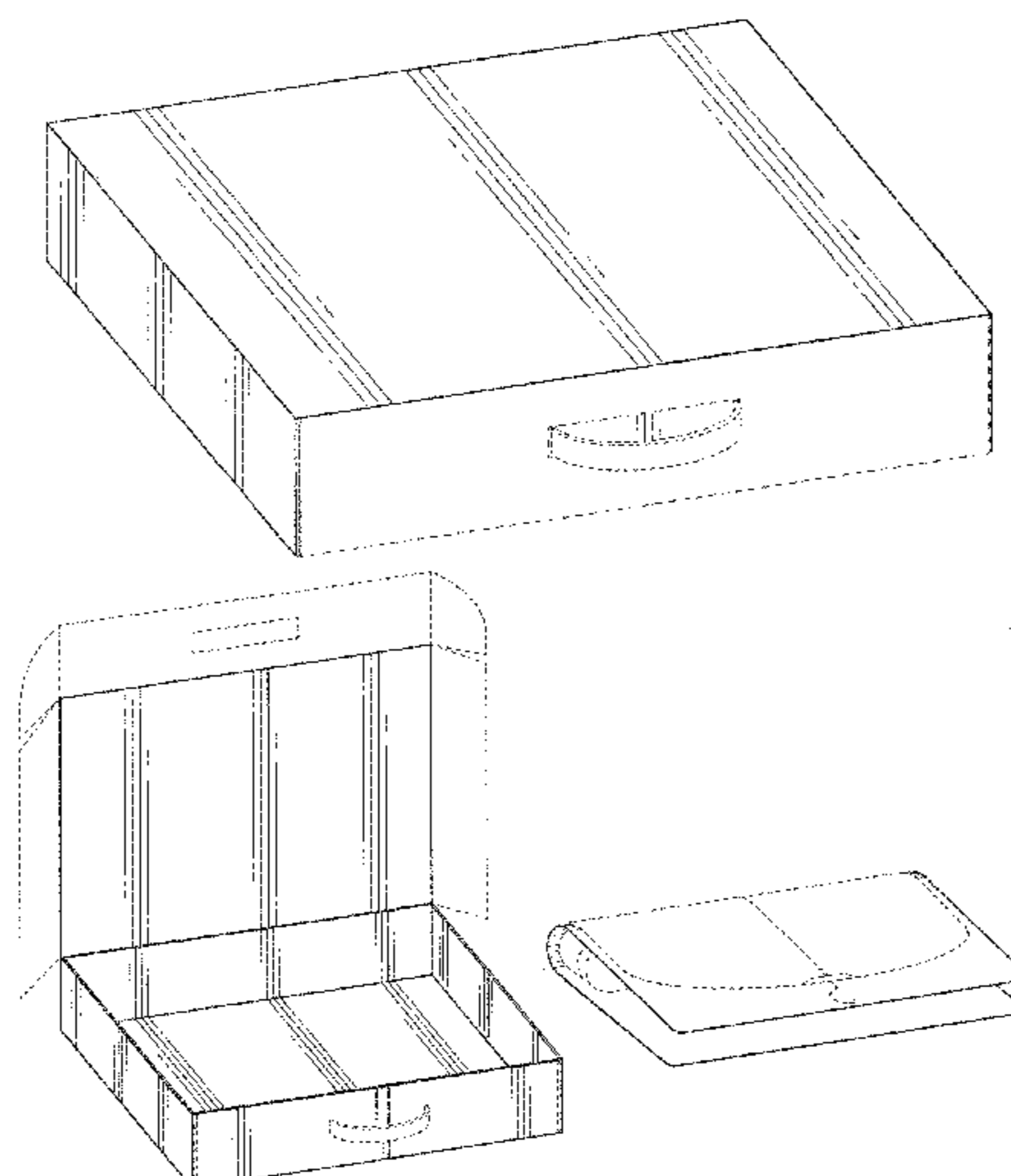

(58) **Field of Classification Search**

CPC ..... B65D 5/38; B65D 5/4204; B65D 5/2009;  
B65D 5/5021; B65D 5/422; B65D  
77/0413; B65D 11/12; B65D 5/22; B65D  
5/5016; B65D 5/54; B65D 25/10; B65D  
5/4266; B65D 5/5007; B65D 5/5435;  
B65D 77/0433; B65D 75/327; B65D  
75/36; B65D 25/04; B65D 25/205; B65D  
5/503; B65D 5/5035; B65D 77/003;  
B65D 77/02

See application file for complete search history.

(56) **References Cited**

U.S. PATENT DOCUMENTS

5,588,587 A \* 12/1996 Stier ..... B65D 5/5455  
206/557  
D385,781 S \* 11/1997 Levine ..... D9/423  
6,851,601 B1 \* 2/2005 Montoya ..... B65D 5/5038  
229/120  
D592,968 S \* 5/2009 Lee ..... D9/432  
D669,352 S \* 10/2012 Paslawski ..... D9/423  
D690,591 S \* 10/2013 Sanders ..... D9/432  
D720,614 S \* 1/2015 Kim ..... D9/432  
D729,636 S \* 5/2015 Steinberger ..... D9/737  
D730,728 S \* 6/2015 Fath ..... D9/432  
D732,333 S \* 6/2015 Mercier ..... D7/323  
D737,688 S \* 9/2015 Stone ..... D9/432  
2011/0253773 A1 \* 10/2011 Lozier ..... B31F 1/0016  
229/103.11  
2013/0161377 A1 \* 6/2013 Nebeker ..... B65D 5/322  
229/116.5

\* cited by examiner

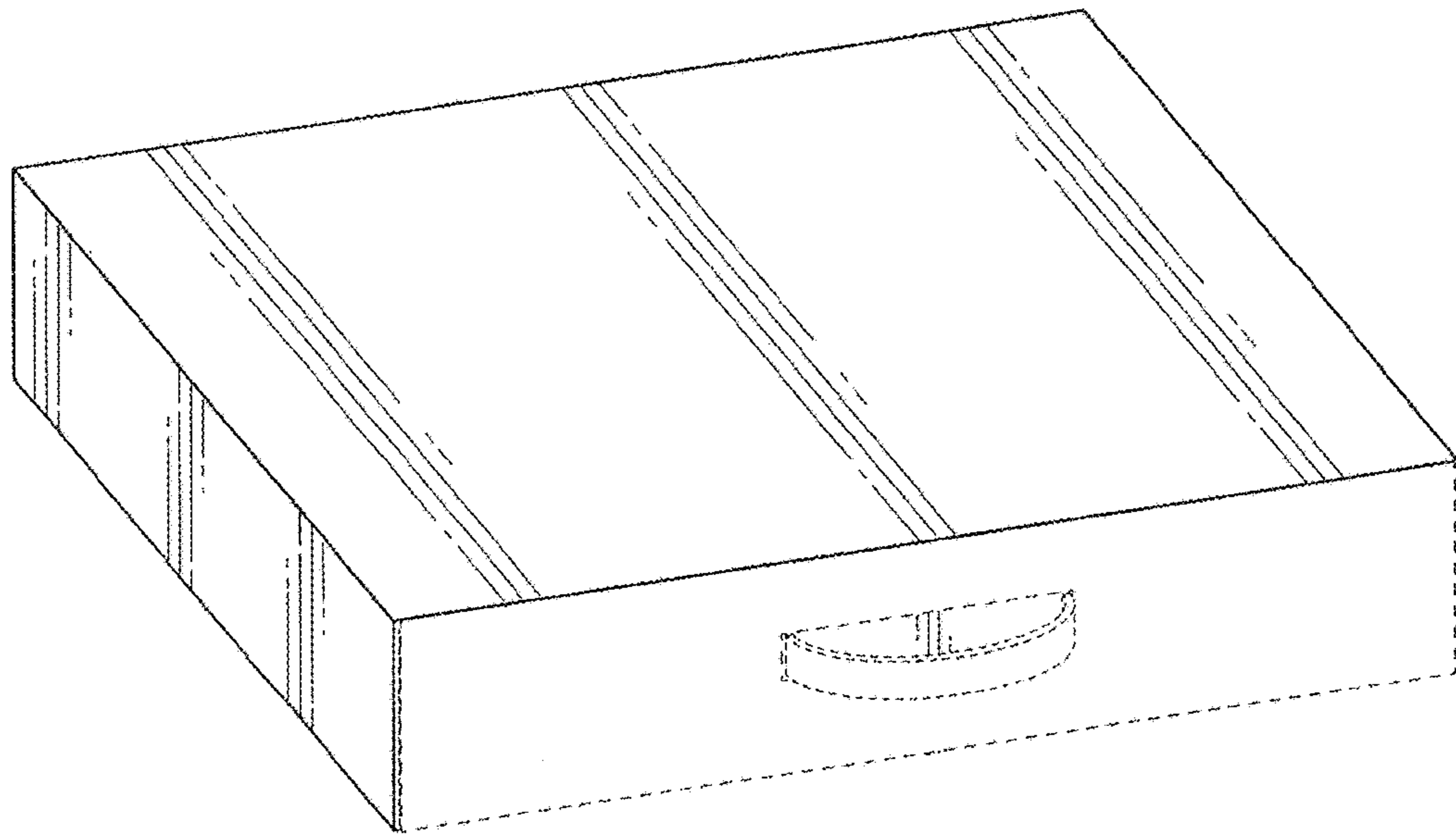

FIG. 1

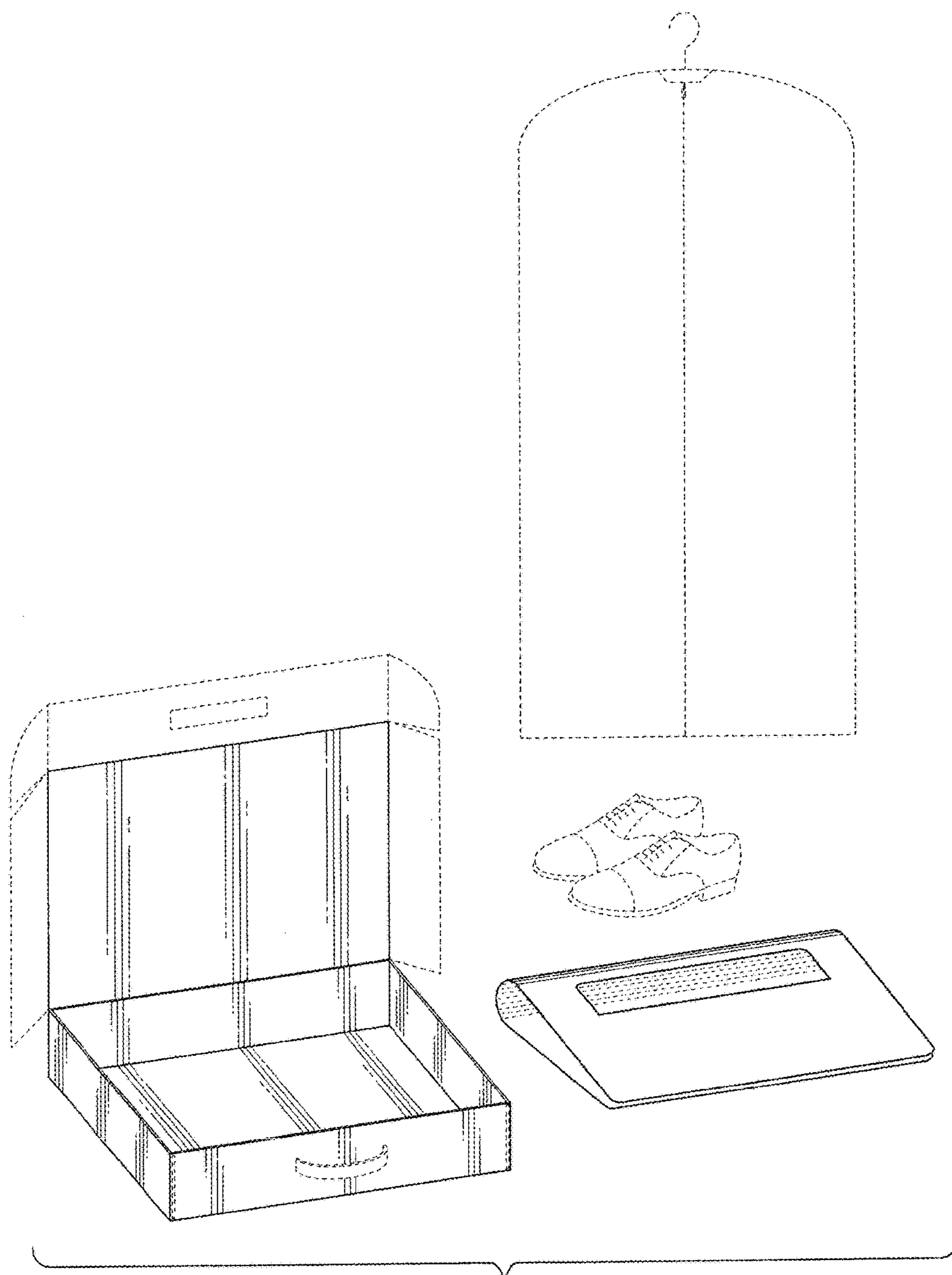

FIG. 2



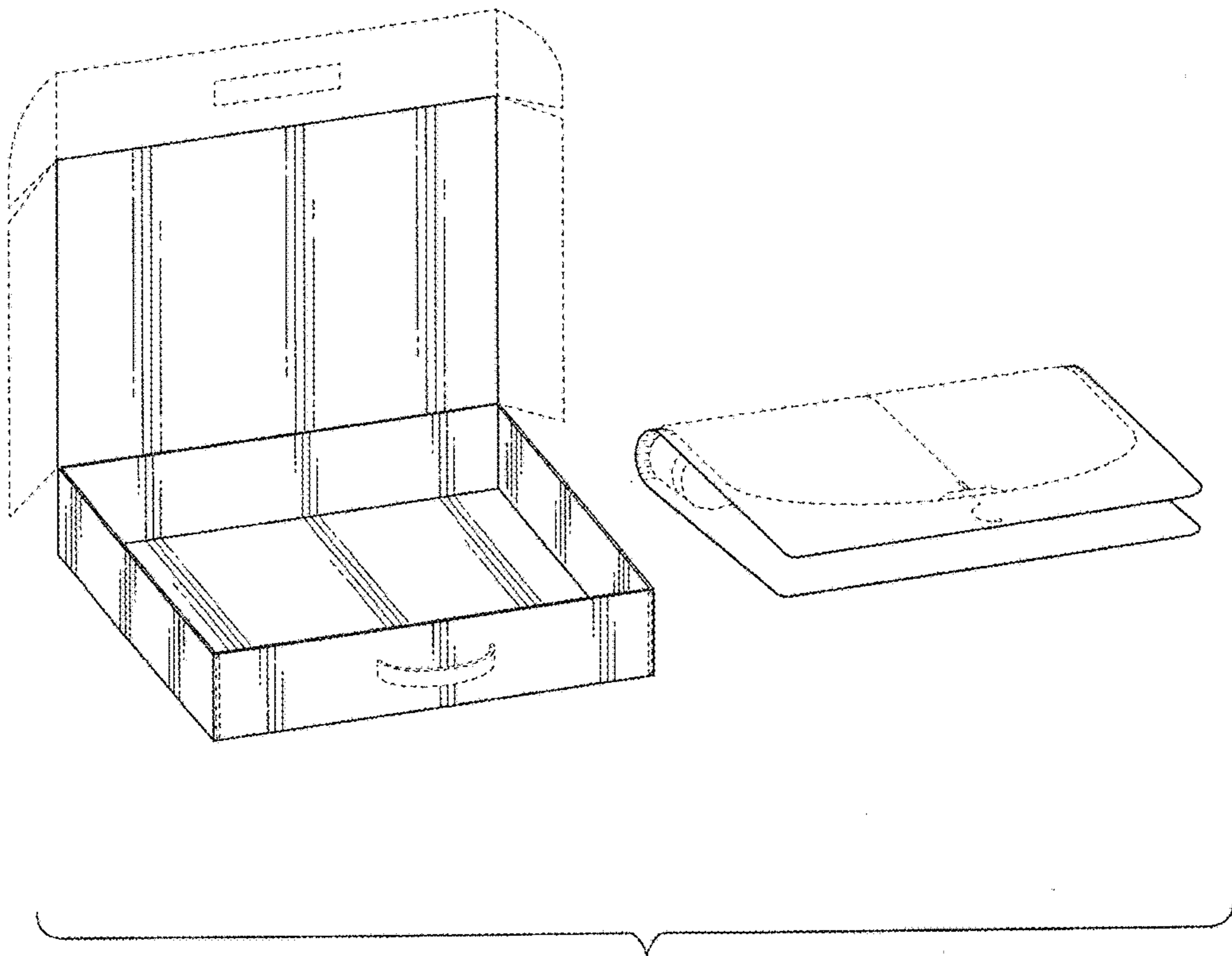

FIG. 3

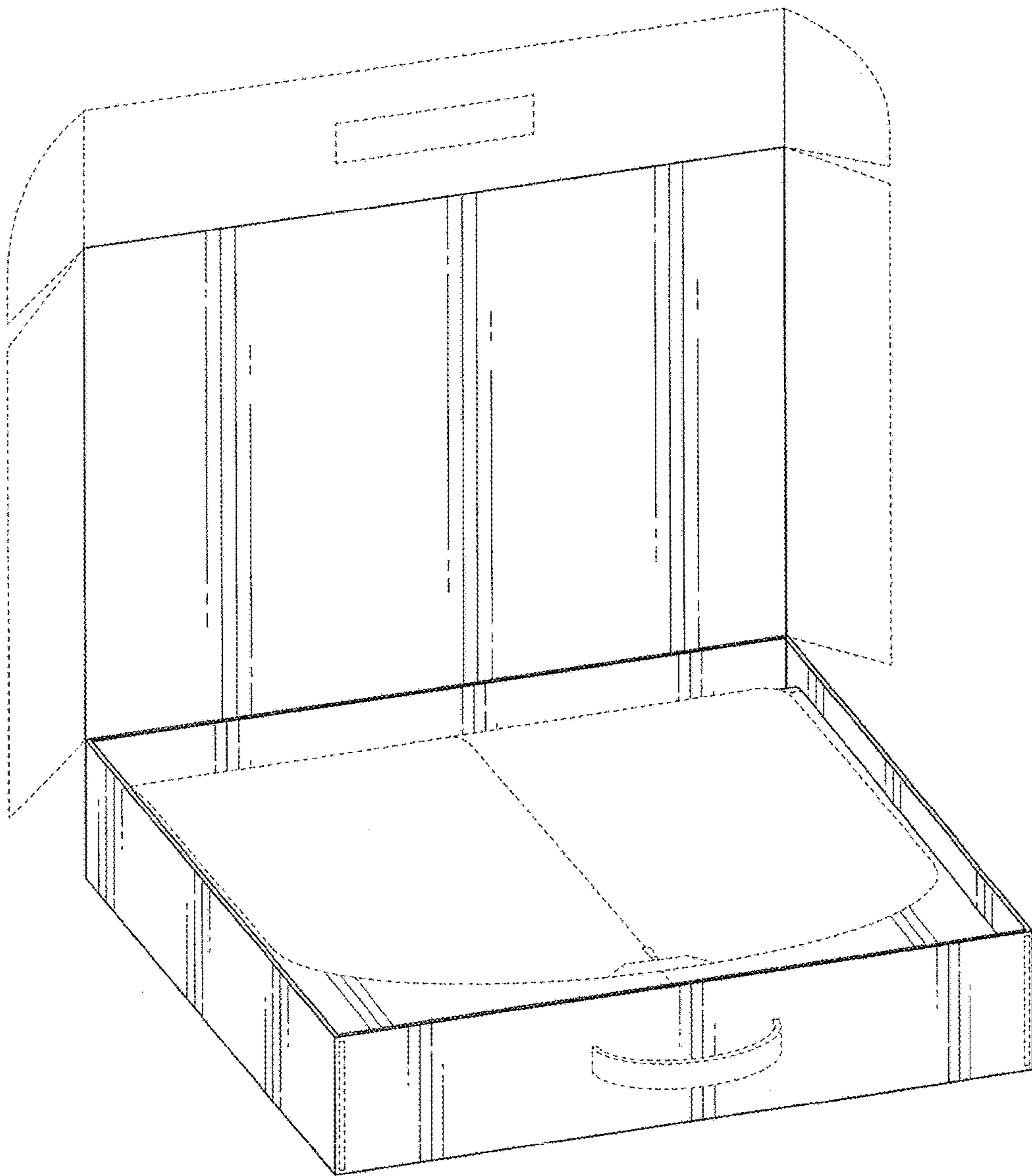

FIG. 4

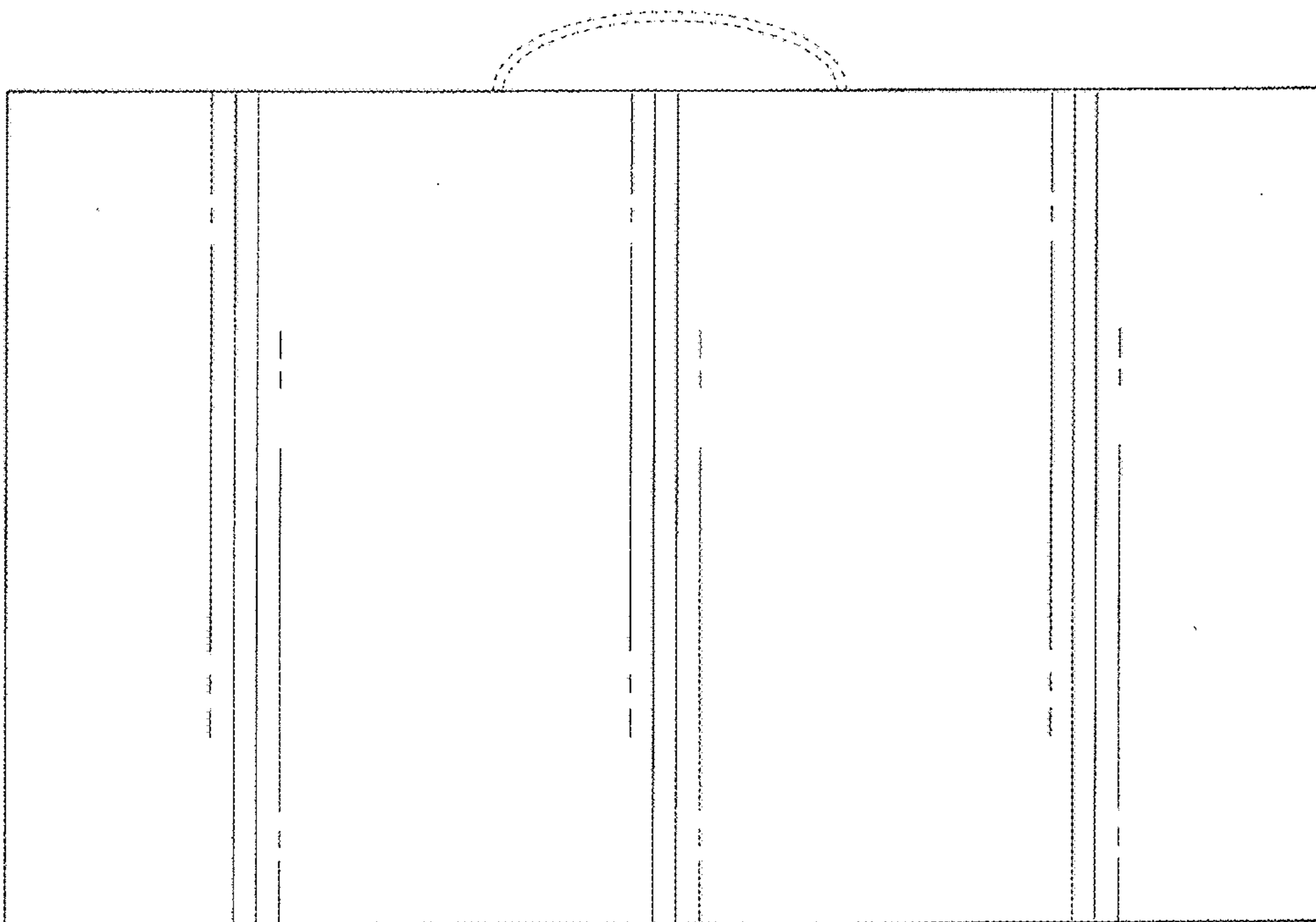

FIG. 5

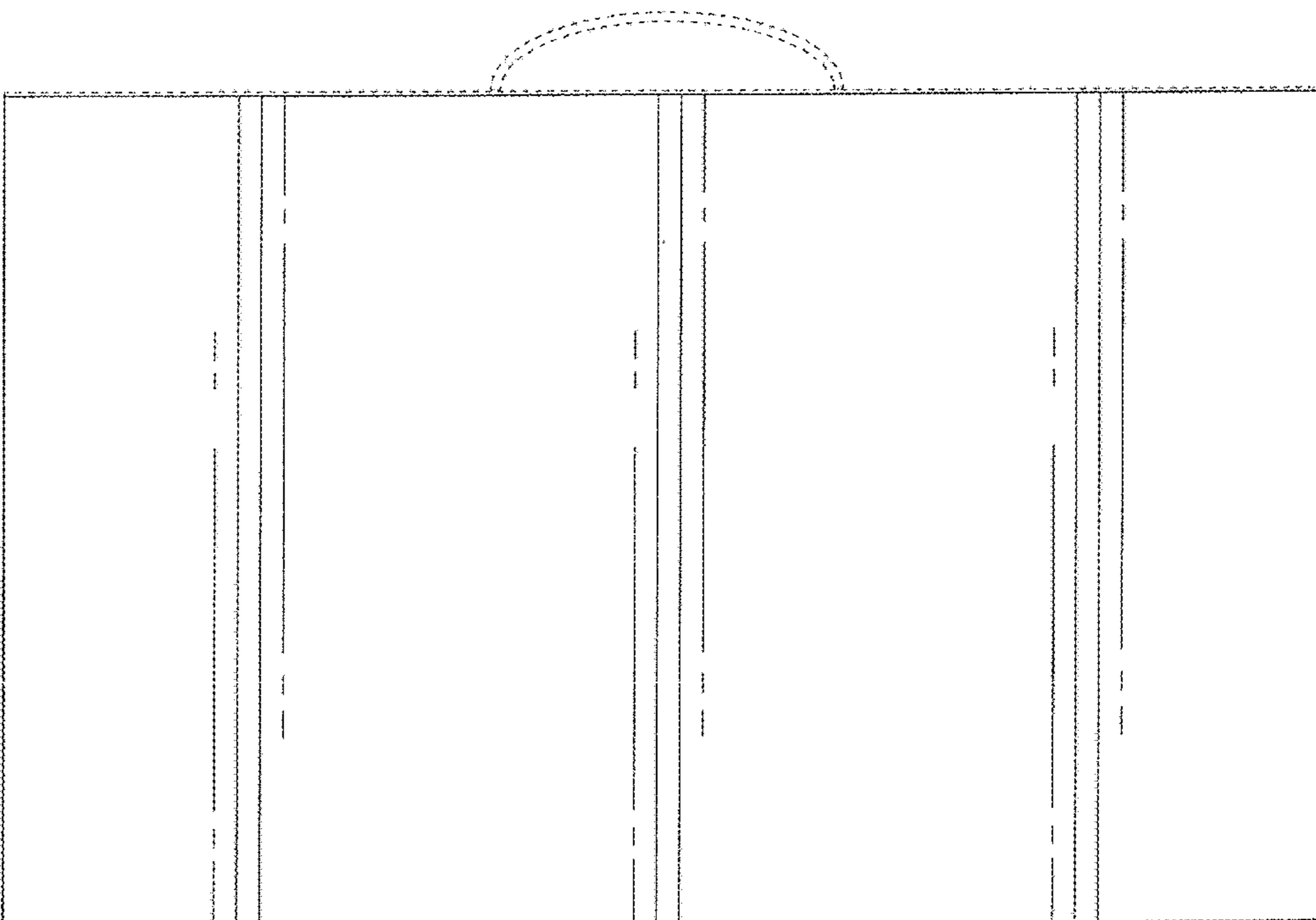

FIG. 6

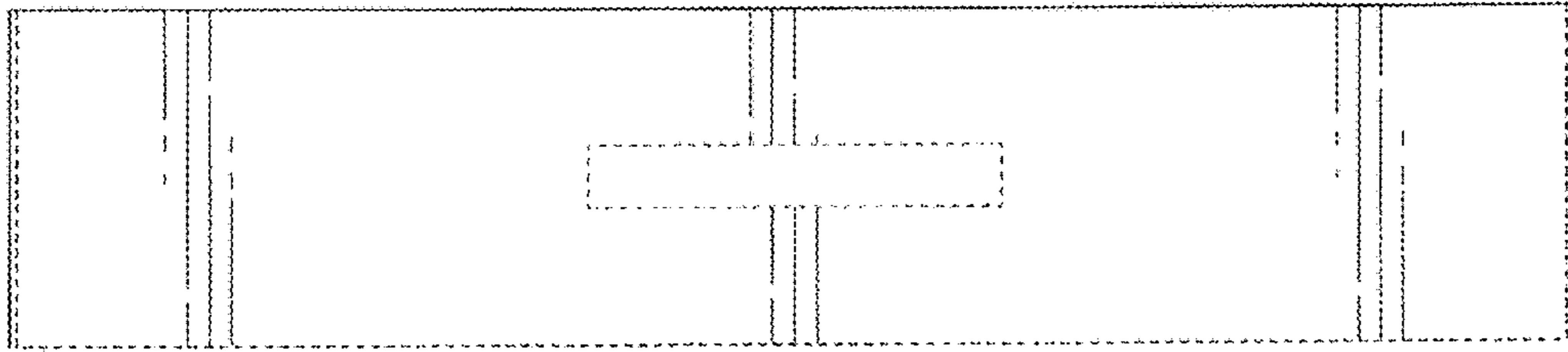

FIG. 7

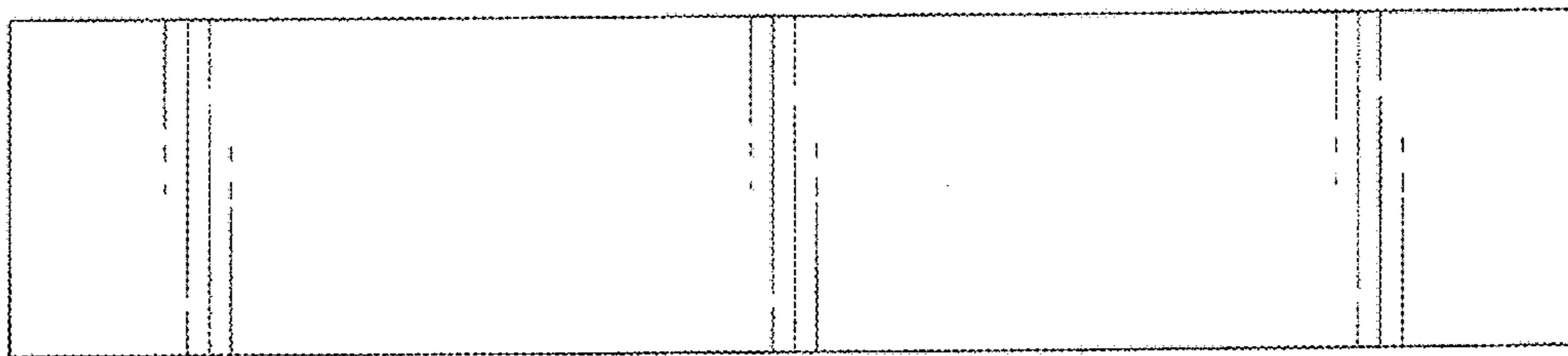

FIG. 8



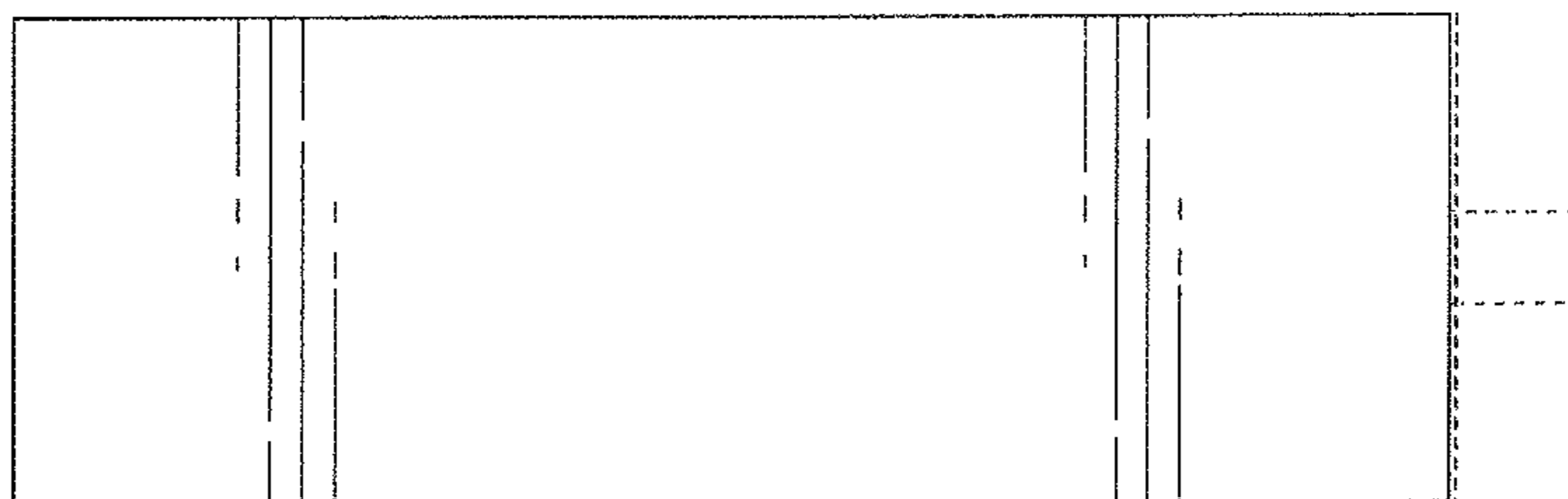

FIG. 9

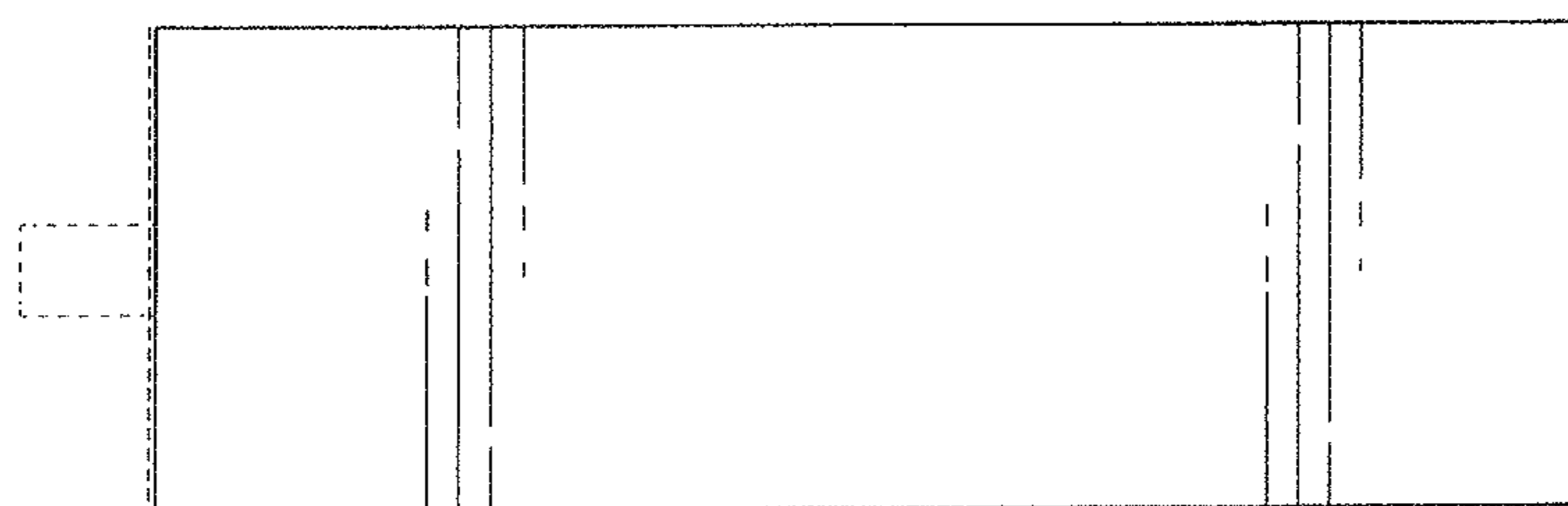

FIG. 10

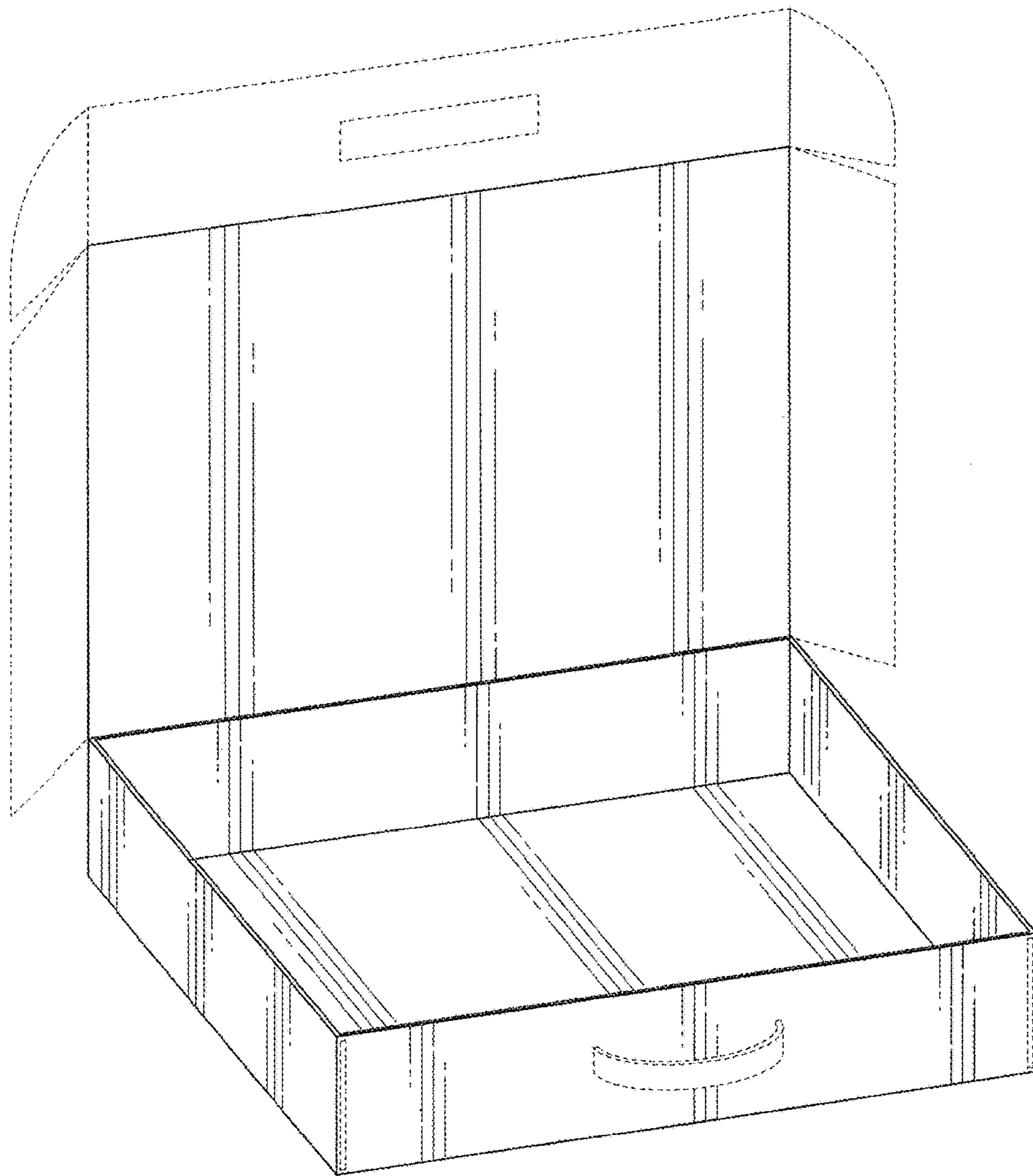

FIG. 11

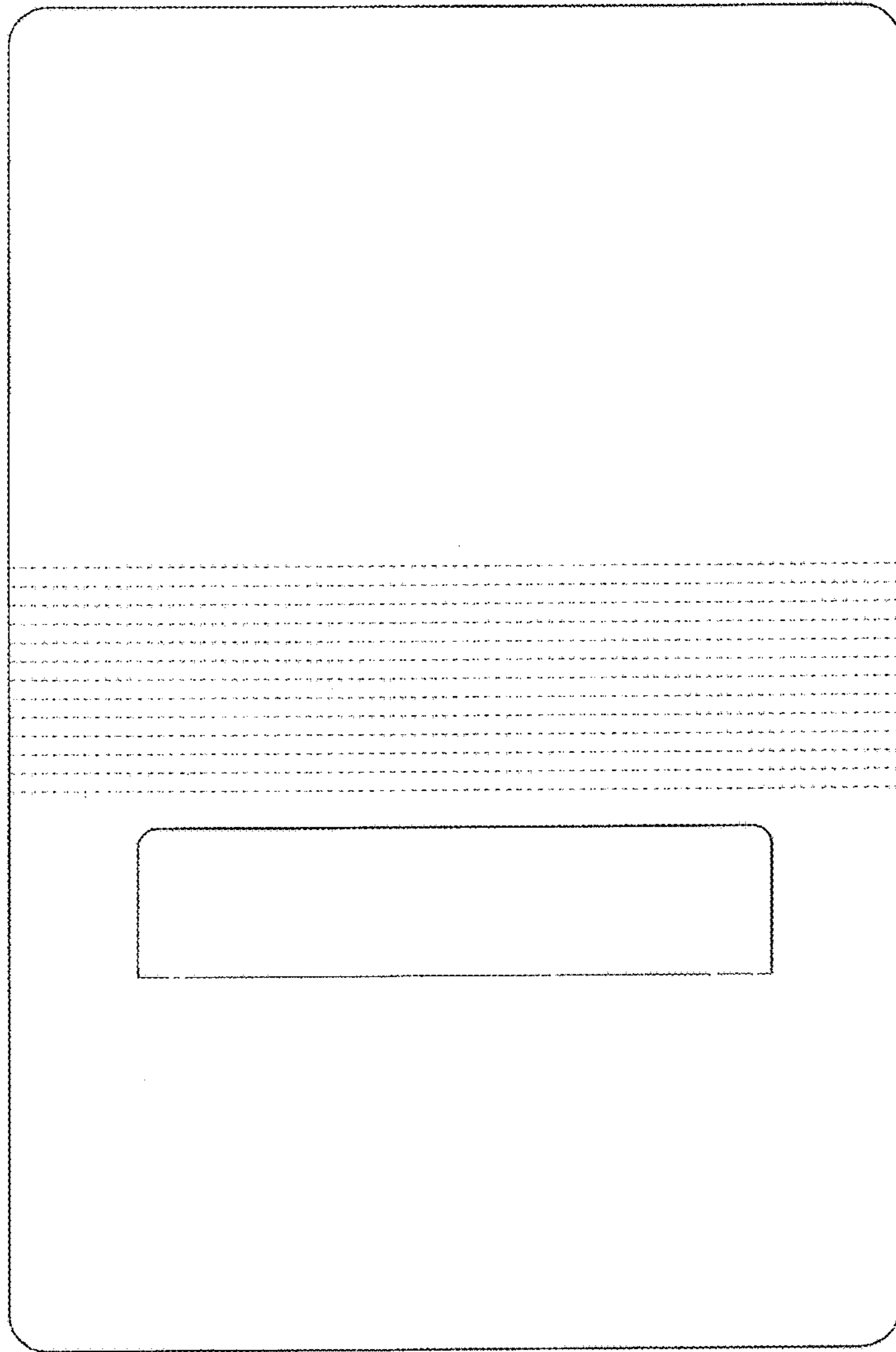

FIG. 12



FIG. 13

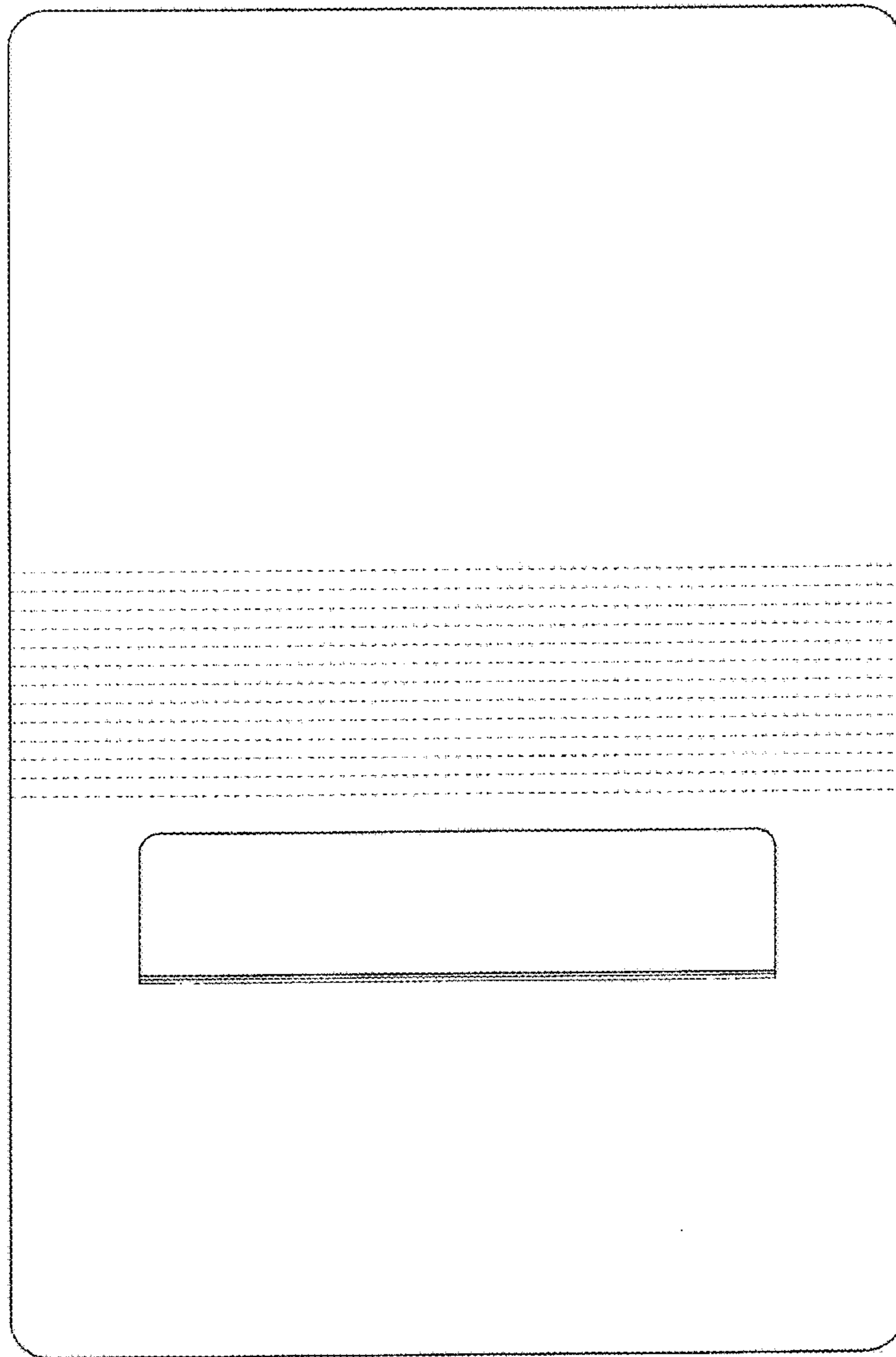

FIG. 14

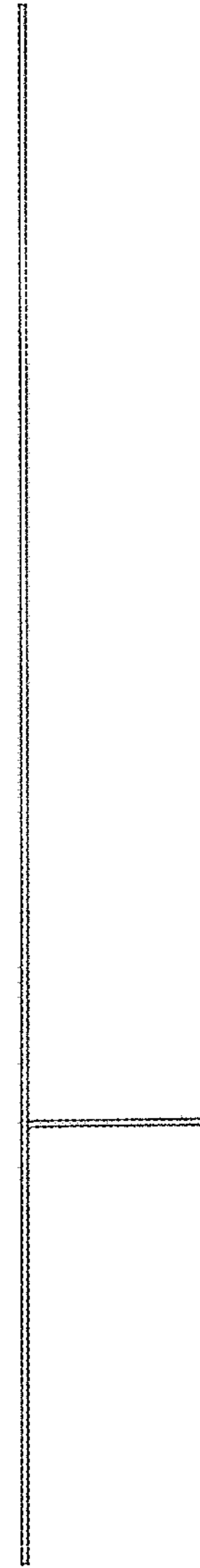

FIG. 15

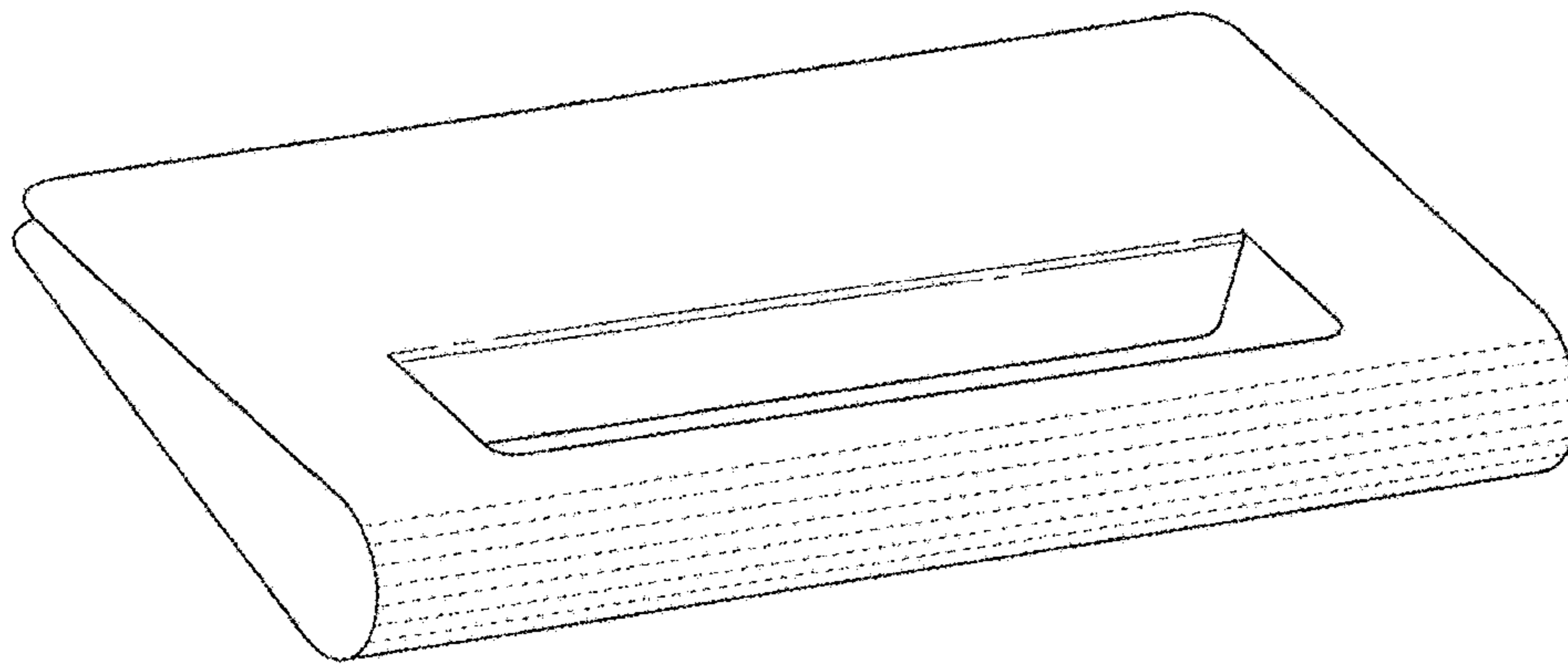

FIG. 16

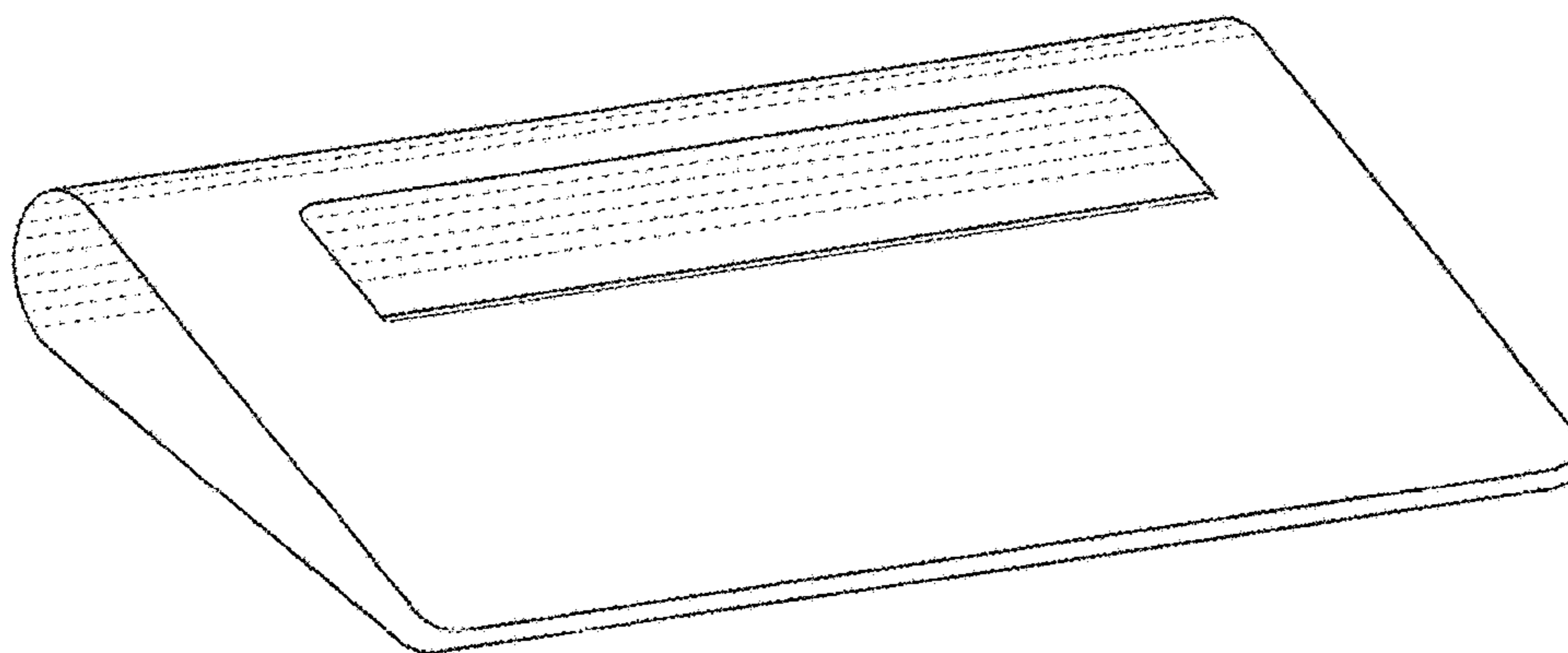

FIG. 17



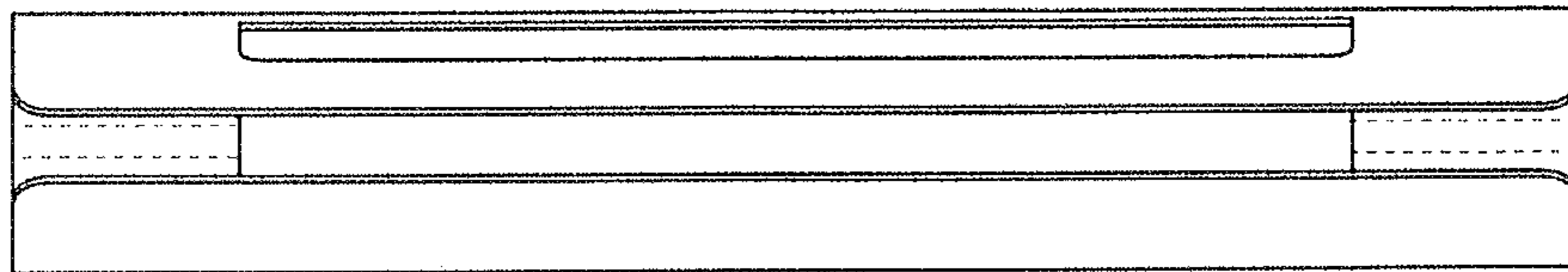

FIG. 18

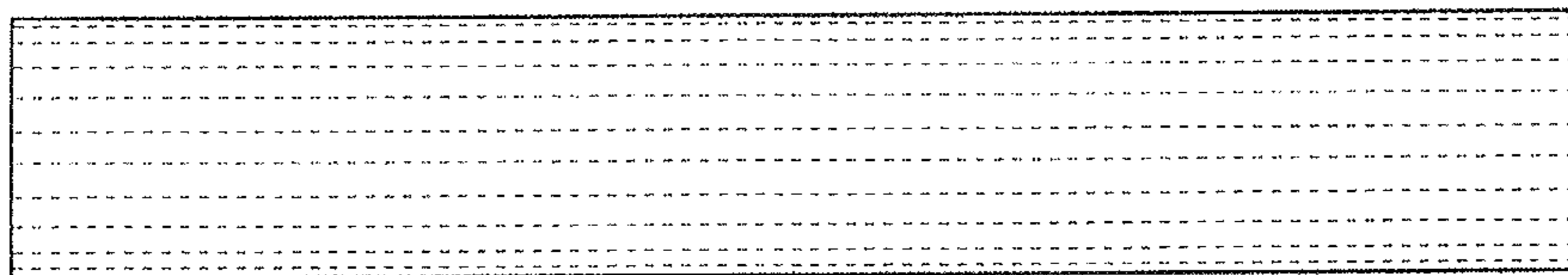

FIG. 19

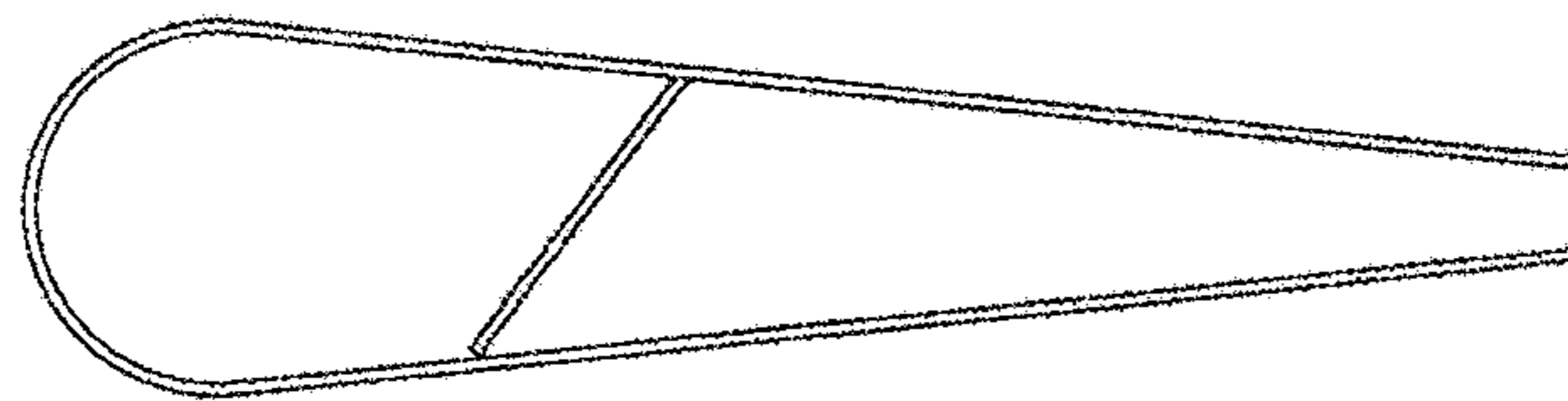

FIG. 20

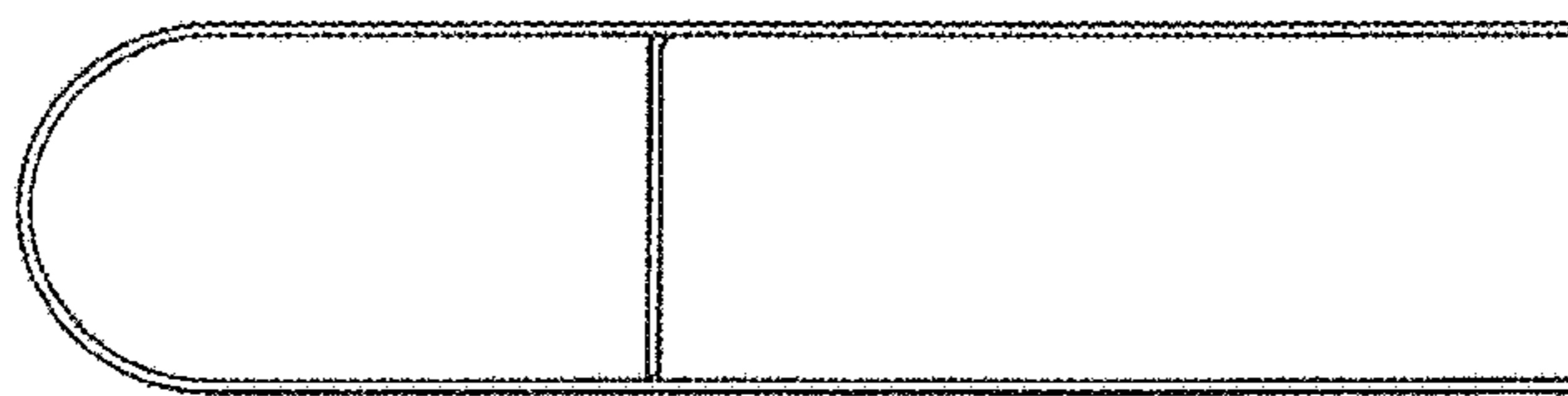

FIG. 21

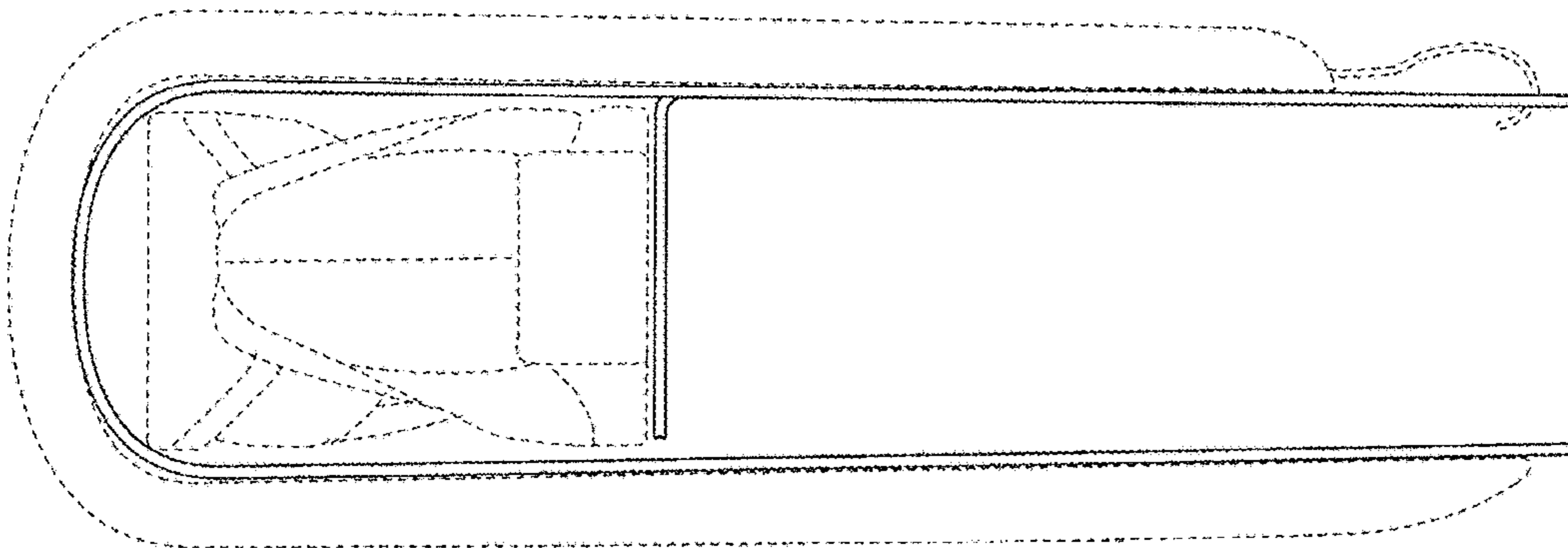

FIG. 22