



US00D824973S

(12) **United States Design Patent**
Tabuchi

(10) **Patent No.:** **US D824,973 S**
(45) **Date of Patent:** **** Aug. 7, 2018**

(54) **ROTARY ACTUATOR**

(71) Applicant: **SMC CORPORATION**, Tokyo (JP)

(72) Inventor: **Toshikazu Tabuchi**, Moriya (JP)

(73) Assignee: **SMC CORPORATION**, Tokyo (JP)

(**) Term: **15 Years**

(21) Appl. No.: **29/628,787**

(22) Filed: **Dec. 7, 2017**

Related U.S. Application Data

(62) Division of application No. 29/560,617, filed on Apr. 8, 2016, now Pat. No. Des. 810,798.

(30) **Foreign Application Priority Data**

Oct. 9, 2015 (CN) 2015 3 0389522

(51) **LOC (11) Cl.** **15-09**

(52) **U.S. Cl.**
USPC **D15/148**

(58) **Field of Classification Search**
USPC D13/147, 148, 158; D15/5, 143, 148,
D15/199; D23/233
CPC F15B 11/076; F15B 11/0413; F15B 15/24;
F15B 15/065; F15B 15/149; F15B
15/1433; F16H 19/04
See application file for complete search history.

(56) **References Cited**

U.S. PATENT DOCUMENTS

D446,229 S 8/2001 Kaneko
D479,542 S 9/2003 Lannoch
D479,725 S 9/2003 Lannoch
D494,659 S 8/2004 Marinoni et al.

(Continued)

FOREIGN PATENT DOCUMENTS

JP 935699 S 9/1995
JP 1345971 S 12/2008

OTHER PUBLICATIONS

Japanese Office Action, dated Apr. 5, 2016, for Japanese Application No. 2015-022290, together with an English translation thereof.

(Continued)

Primary Examiner — Patricia Ann Palasik

(74) *Attorney, Agent, or Firm* — Birch, Stewart, Kolasch & Birch, LLP

(57) **CLAIM**

The ornamental design for a rotary actuator, as shown and described.

DESCRIPTION

FIG. 1 is a front, top and left side perspective view of a rotary actuator showing my new design;
FIG. 2 is a rear, bottom and right side perspective view thereof;
FIG. 3 is a front view thereof;
FIG. 4 is a rear view thereof;
FIG. 5 is a top plan view thereof;
FIG. 6 is a bottom plan view thereof;
FIG. 7 is a left side view thereof;
FIG. 8 is a right side view thereof;
FIG. 9 is a front, top and left side perspective view of a rotary actuator showing a second embodiment of my new design;
FIG. 10 is a rear, bottom and right side perspective view thereof;
FIG. 11 is a front view thereof;
FIG. 12 is a rear view thereof;
FIG. 13 is a top plan view thereof;
FIG. 14 is a bottom plan view thereof;
FIG. 15 is a left side view thereof; and,
FIG. 16 is a right side view thereof.

1 Claim, 16 Drawing Sheets

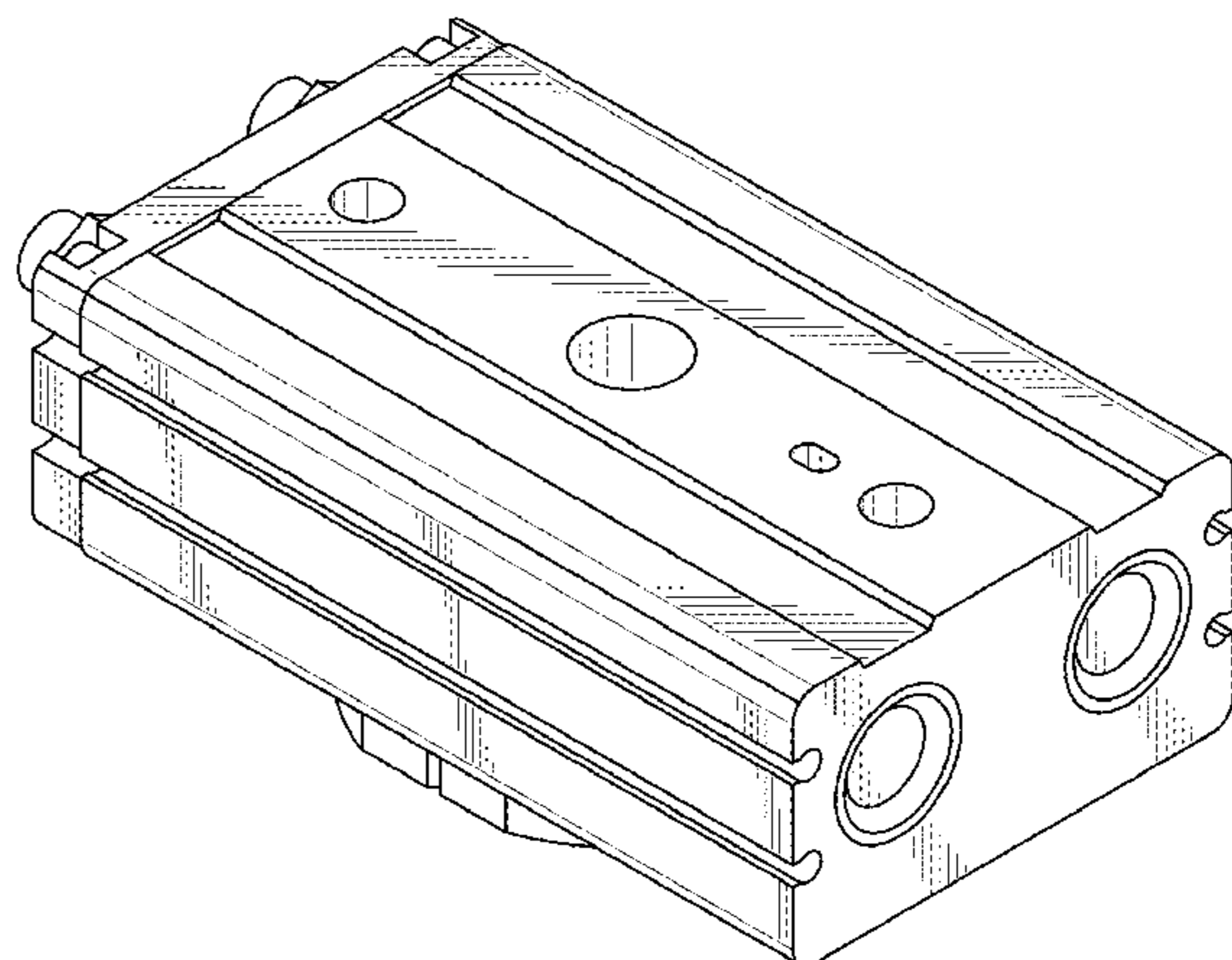
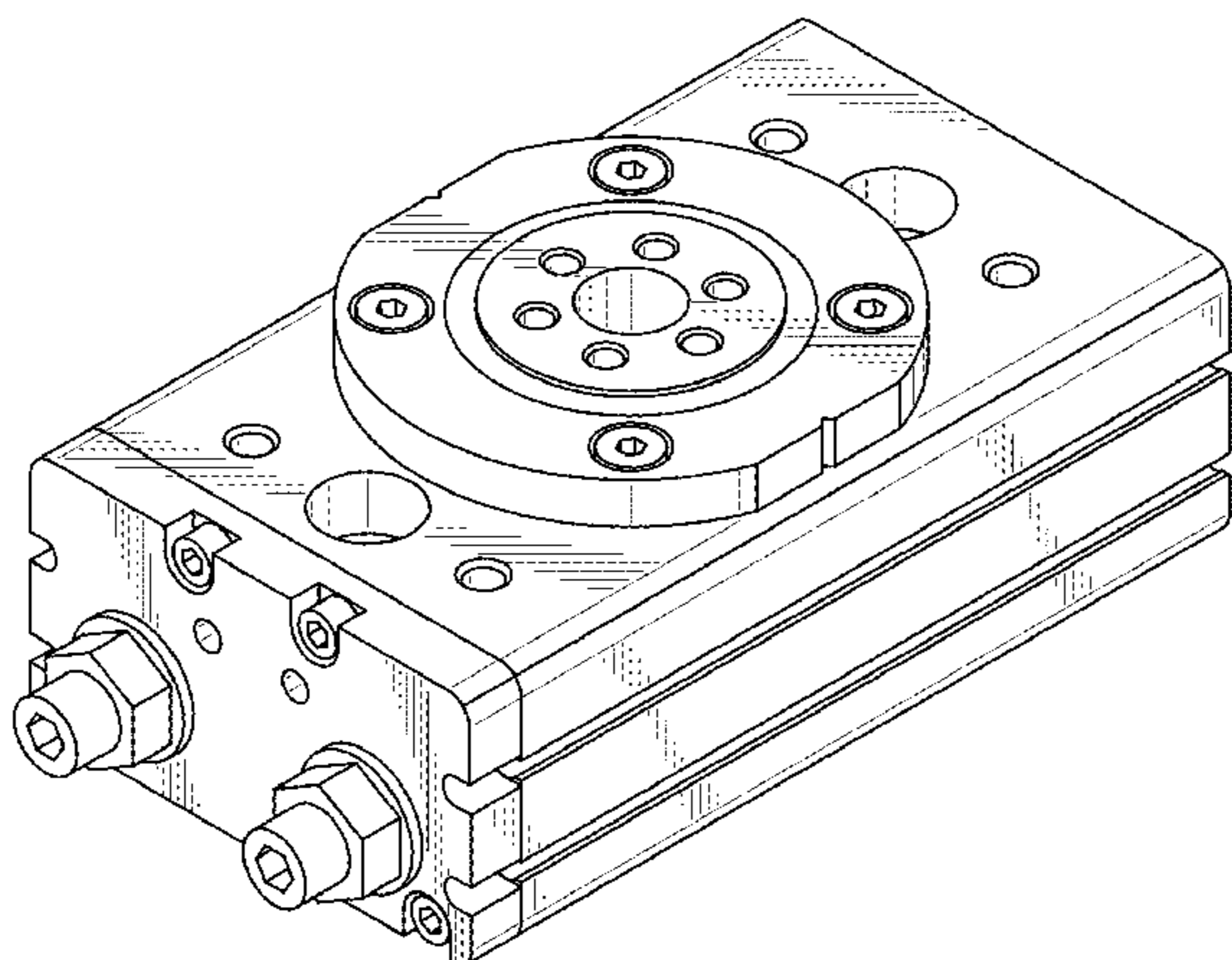

(56)

References Cited

U.S. PATENT DOCUMENTS

D578,147 S	10/2008	Fukano et al.	
D597,111 S	7/2009	Takeuchi et al.	
D597,112 S	7/2009	Takeuchi et al.	
D598,938 S	8/2009	Mijno	
D619,631 S	7/2010	Otsuka	
D628,219 S	11/2010	Fukano et al.	
D629,872 S	12/2010	Marinoni et al.	
D639,321 S	6/2011	Torii et al.	
D660,333 S *	5/2012	Takeuchi	D15/143
D660,334 S *	5/2012	Takeuchi	D15/143
D674,423 S *	1/2013	Mangold	D15/143
D702,271 S *	4/2014	Lin	D15/143
D748,704 S *	2/2016	Jenny	D15/143
D792,916 S *	7/2017	Kobayashi	D15/148
D810,164 S *	2/2018	Lin	D15/148
D810,798 S *	2/2018	Tabuchi	D15/148
2003/0041598 A1	3/2003	Takeuchi et al.	

OTHER PUBLICATIONS

Japanese Office Action, dated Apr. 5, 2016, for Japanese Application No. 2015-022291, together with an English translation thereof.
 Japanese Office Action, dated Apr. 5, 2016, for Japanese Application No. 2015-022292, together with an English translation thereof.
 Japanese Office Action, dated Apr. 5, 2016, for Japanese Application No. 2015-022293, together with an English translation thereof.
 SMC Corporation, New Product Information SMC Shuttle, Rotary Actuator, Publicly Known Design No. HC0902508700, Oct. 31, 1997, 2 pages. (together with English translation).

* cited by examiner

FIG. 1

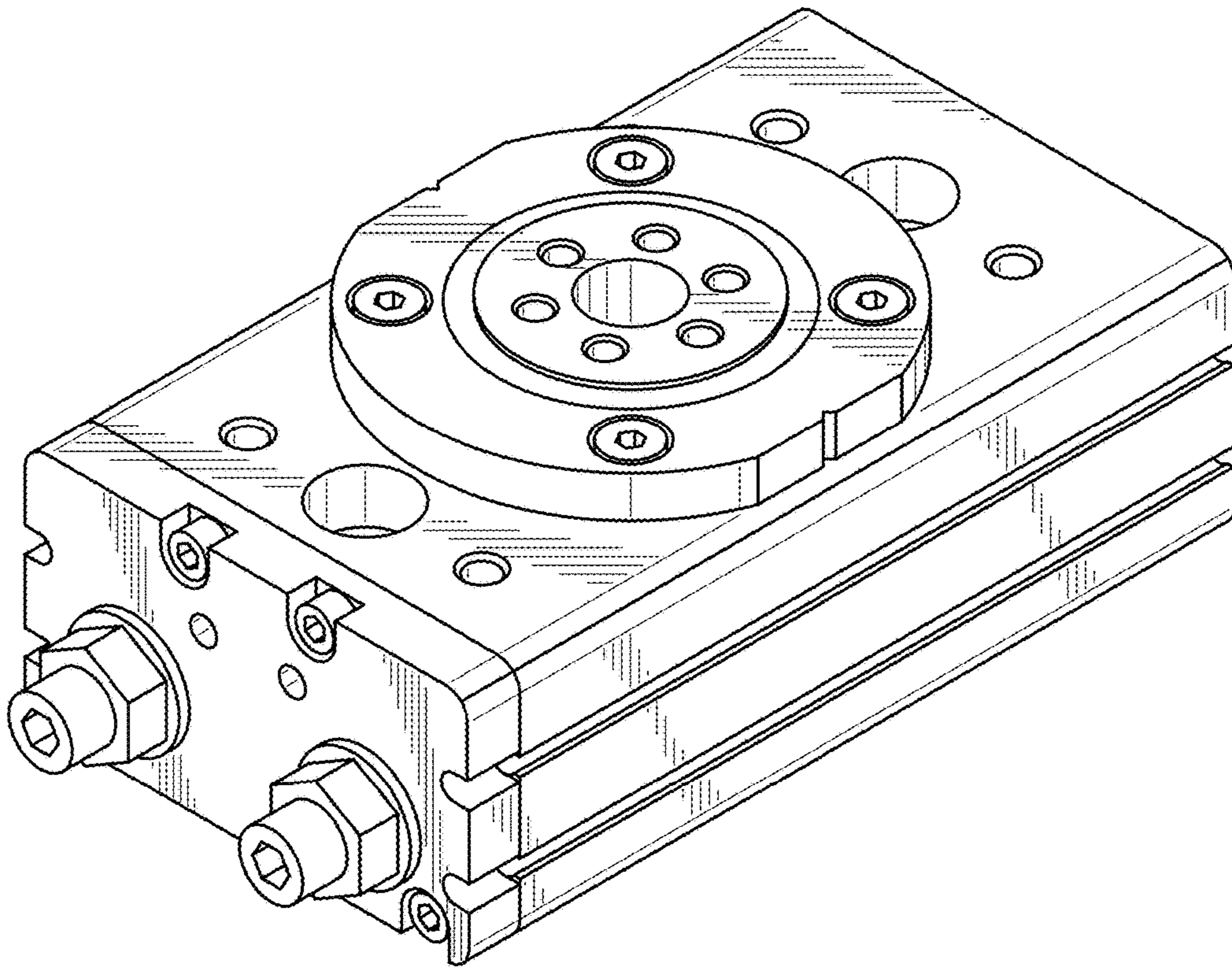

FIG. 2

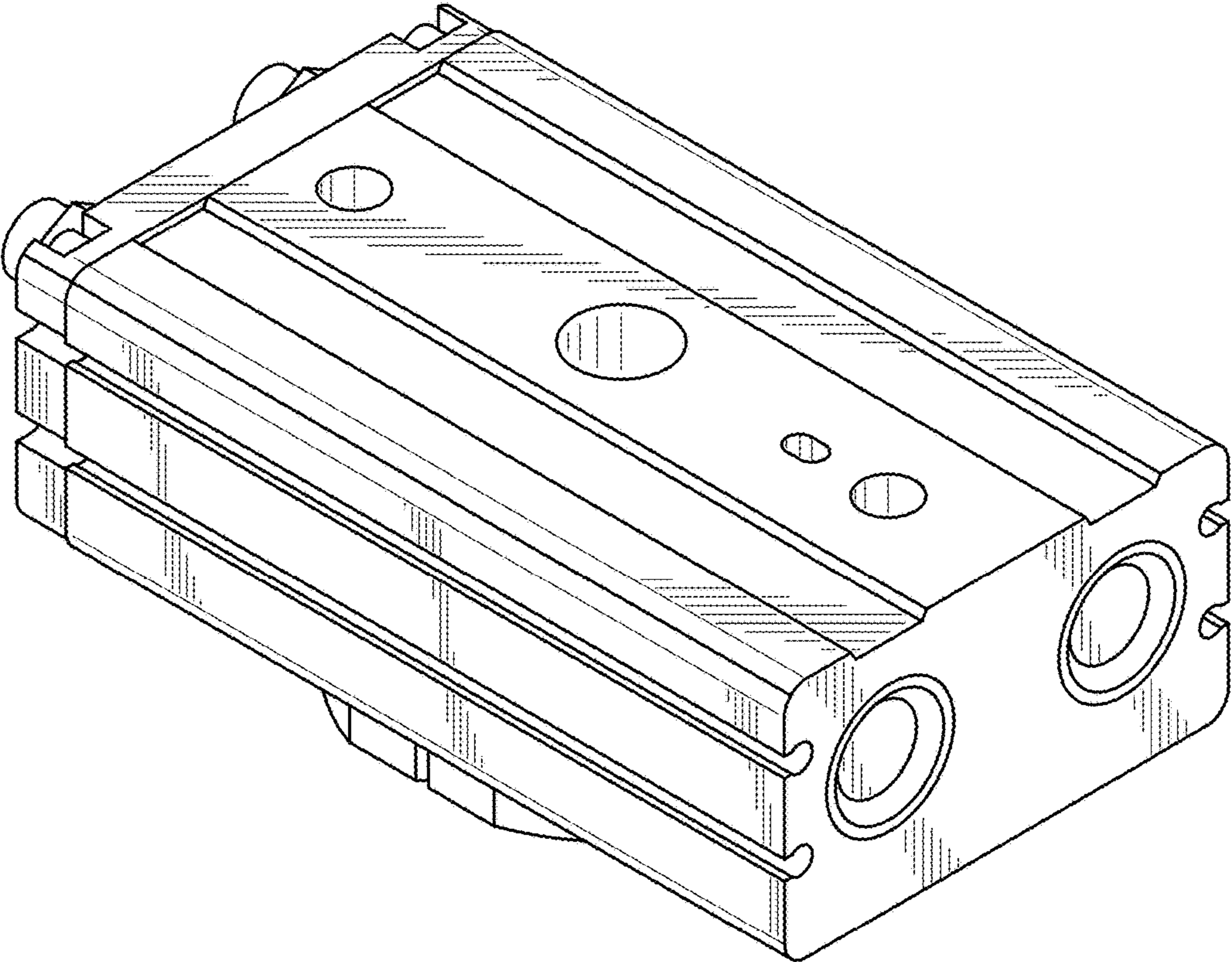

FIG. 3

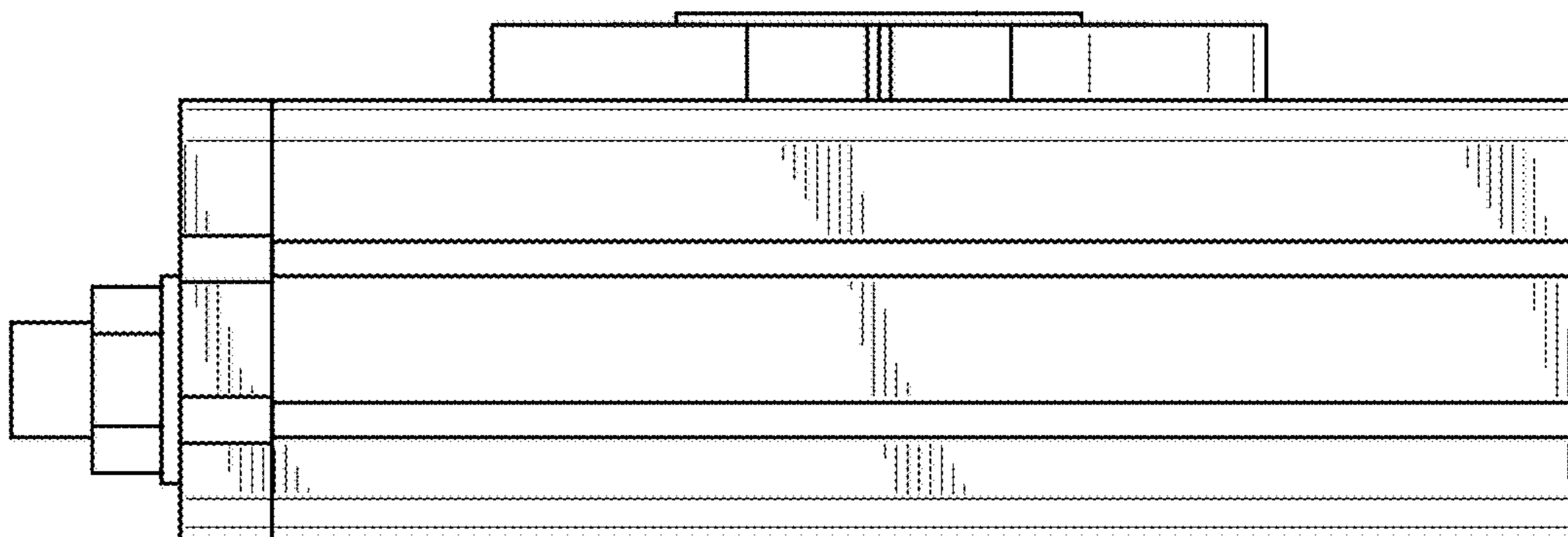

FIG. 4

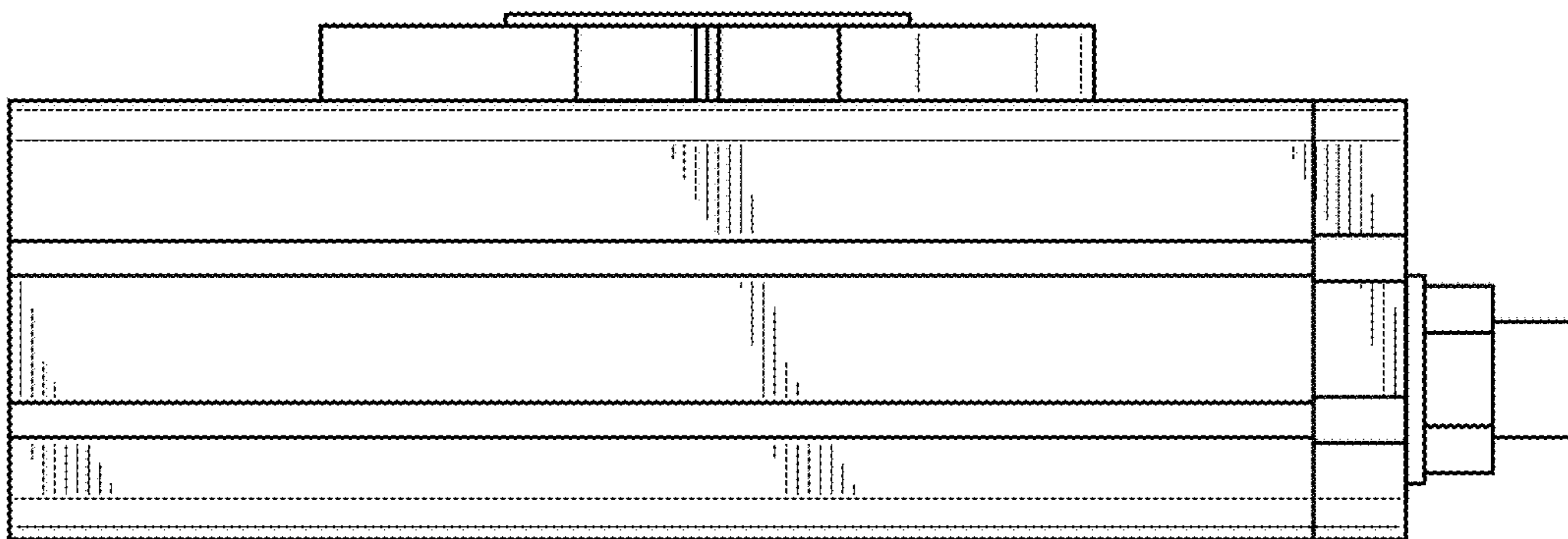

FIG. 5

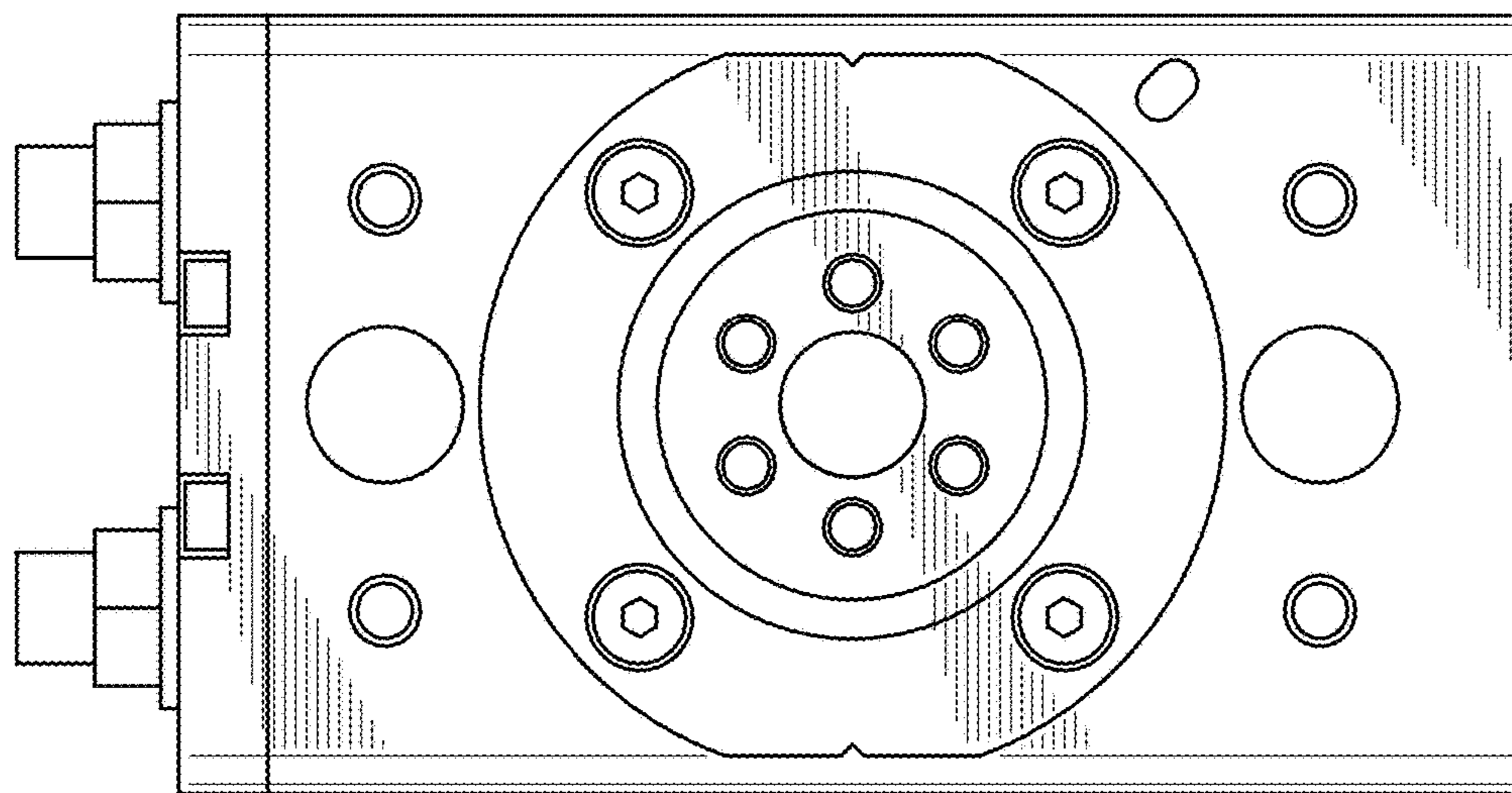

FIG. 6

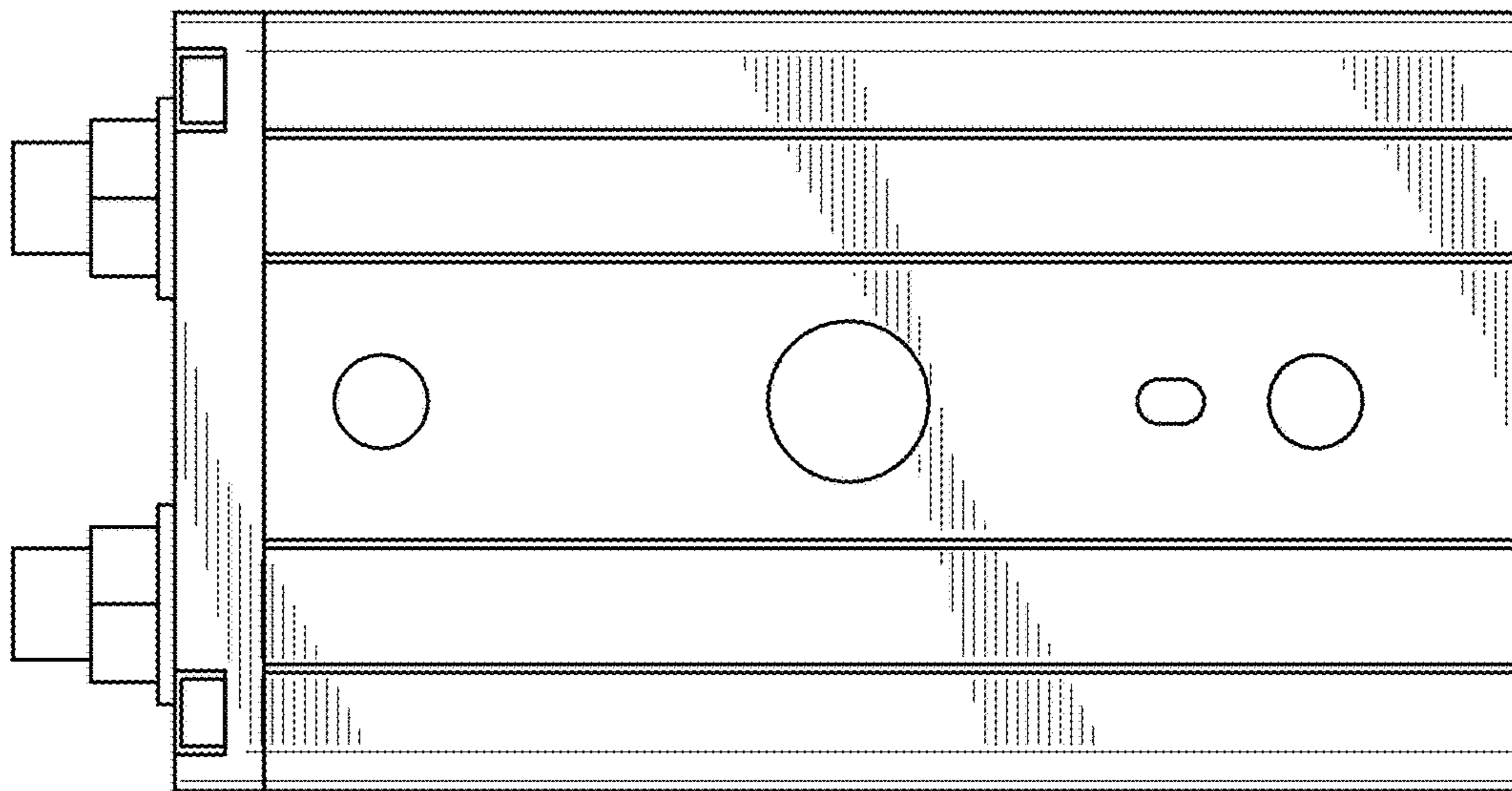

FIG. 7

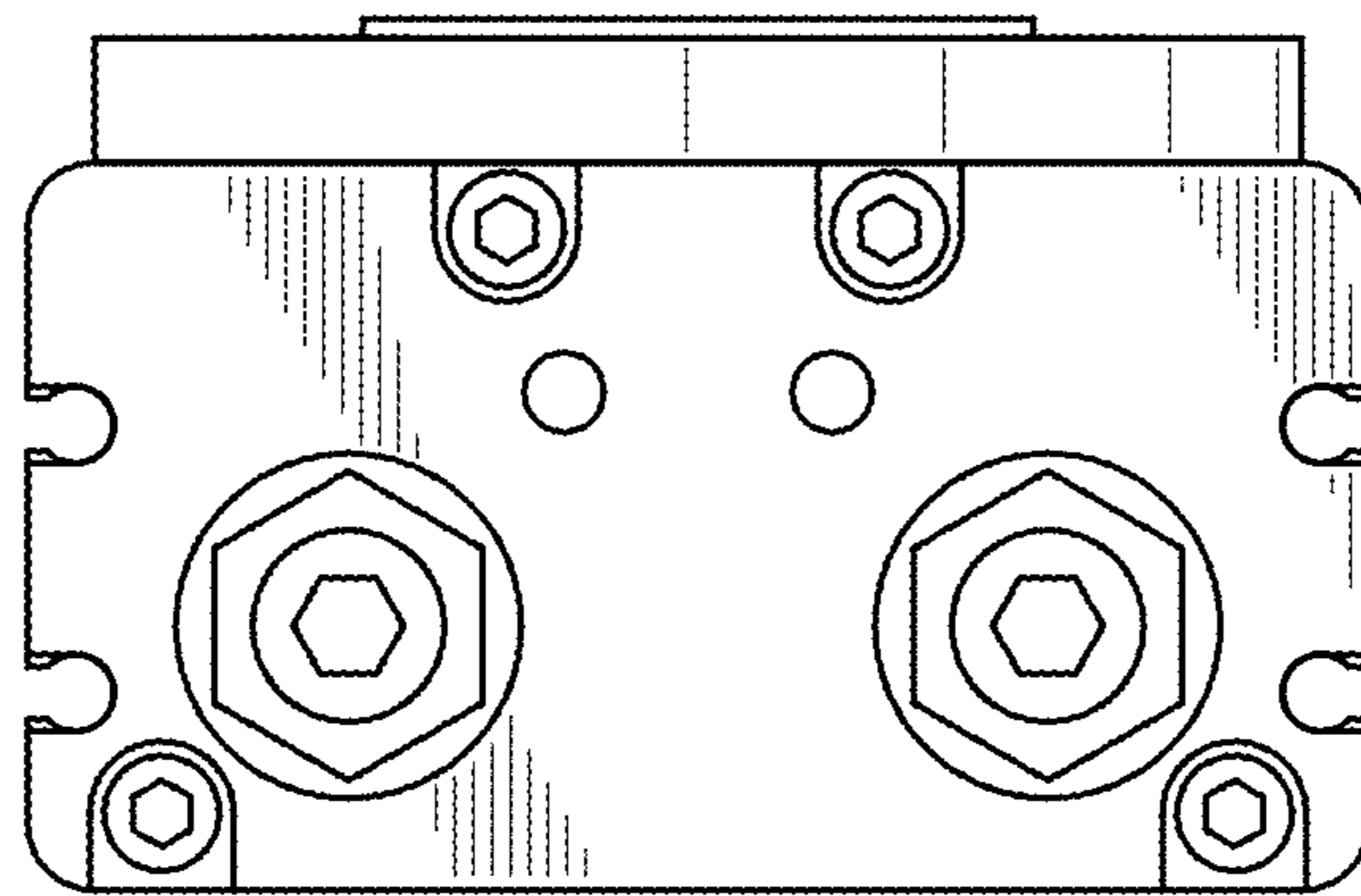

FIG. 8

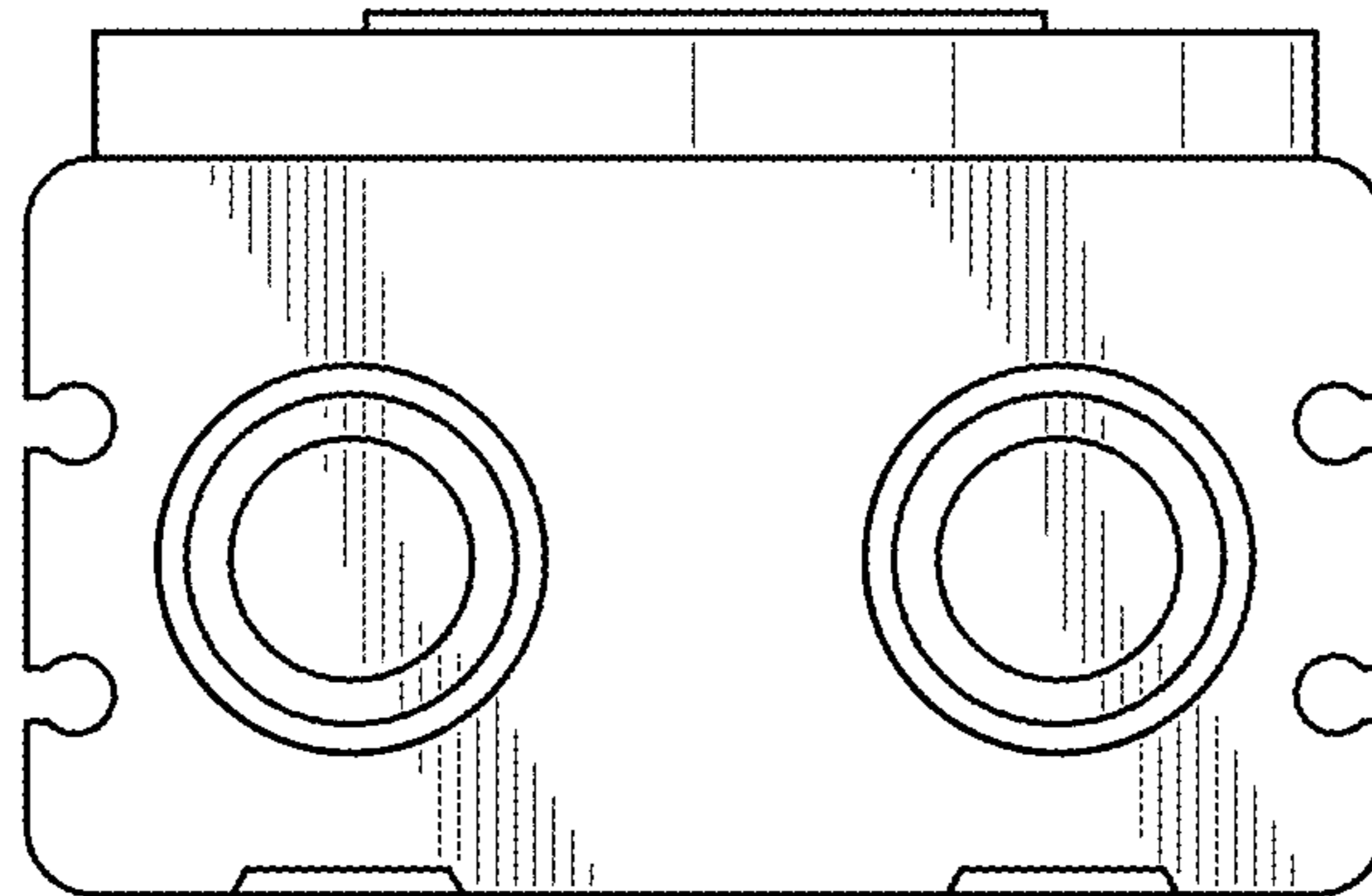

FIG. 9

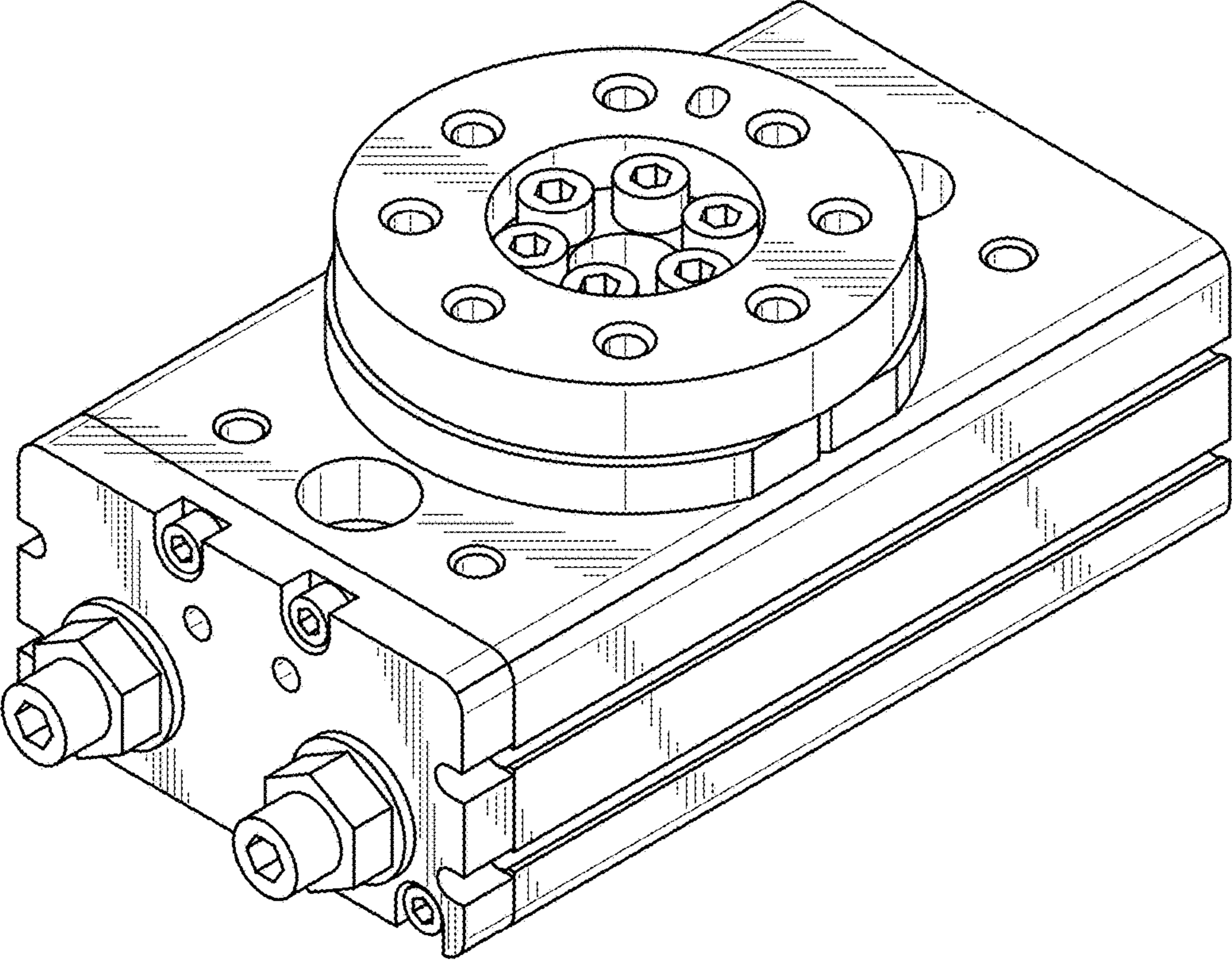

FIG. 10

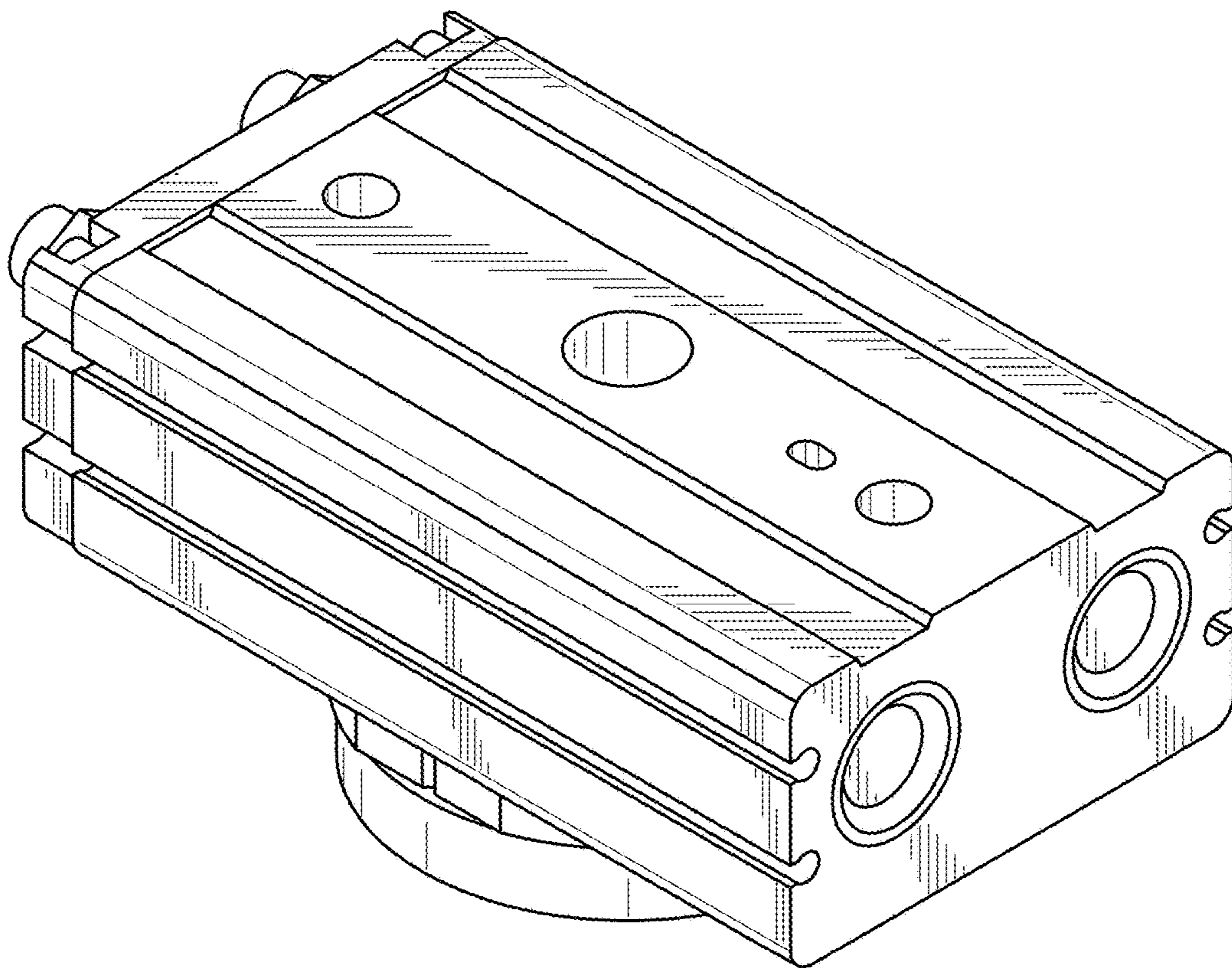

FIG. 11

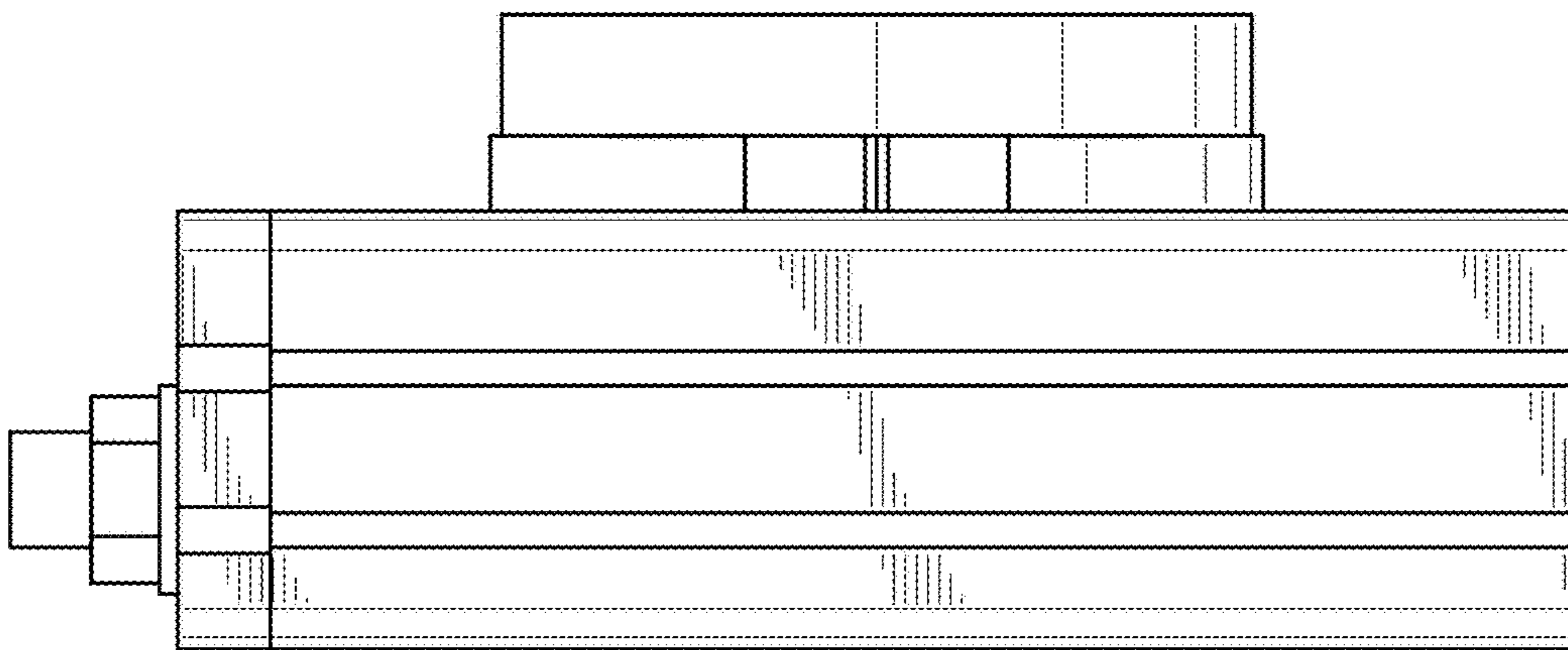

FIG. 12

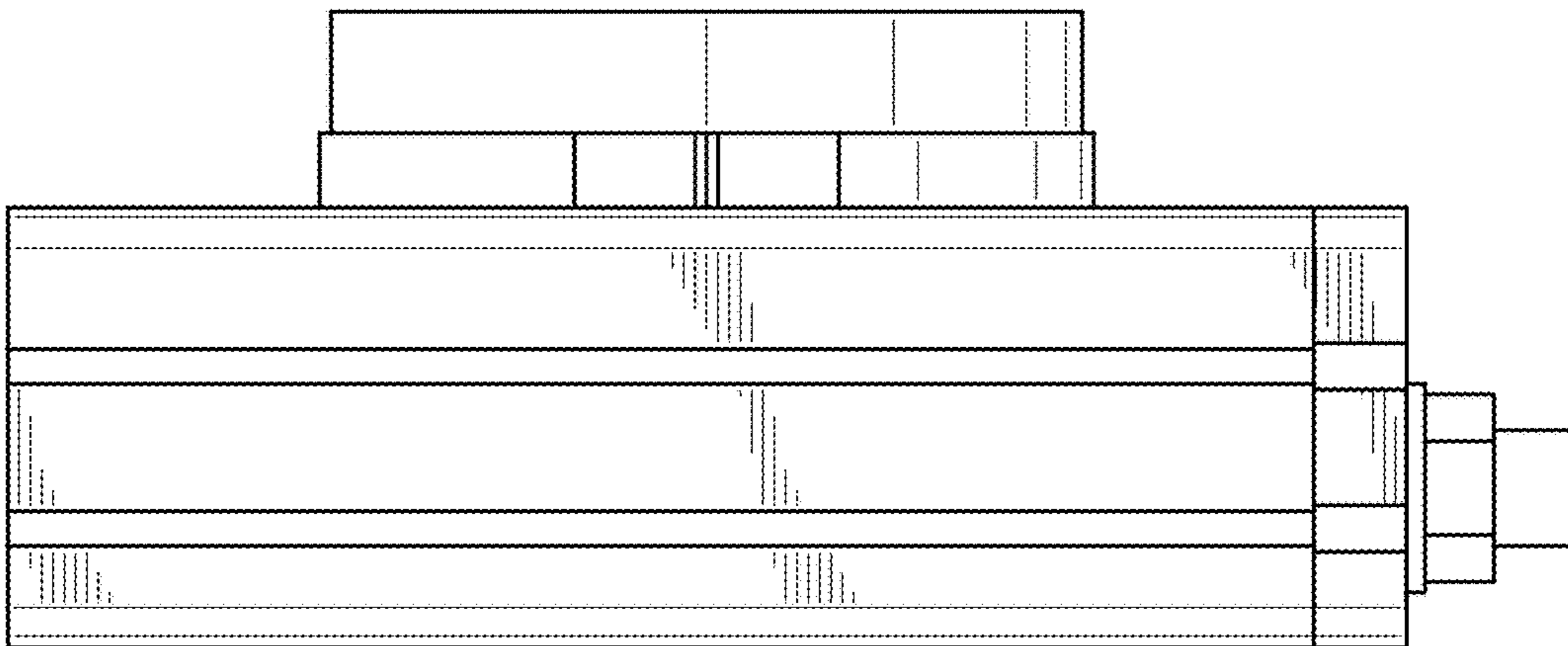

FIG. 13

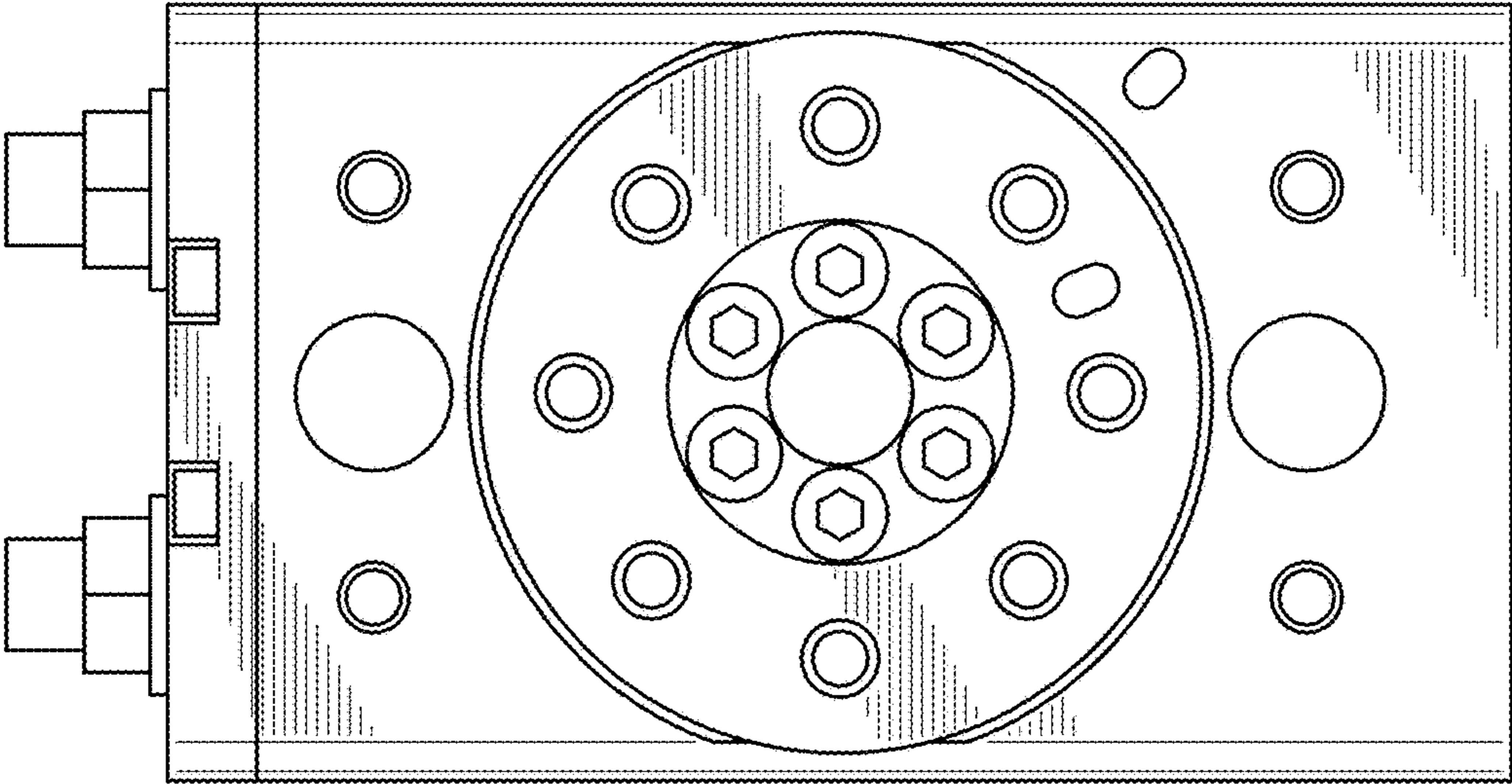

FIG. 14

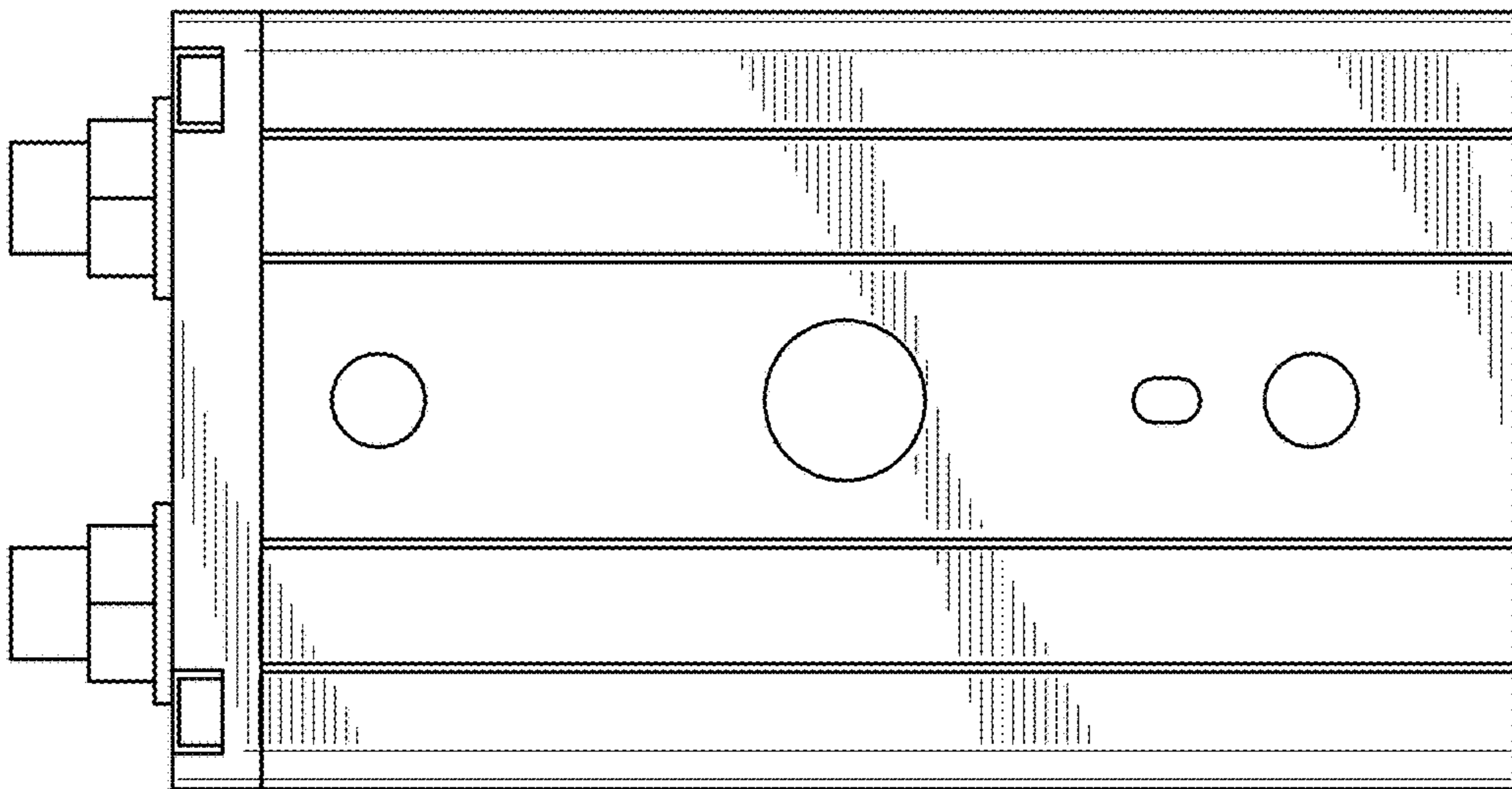

FIG. 15

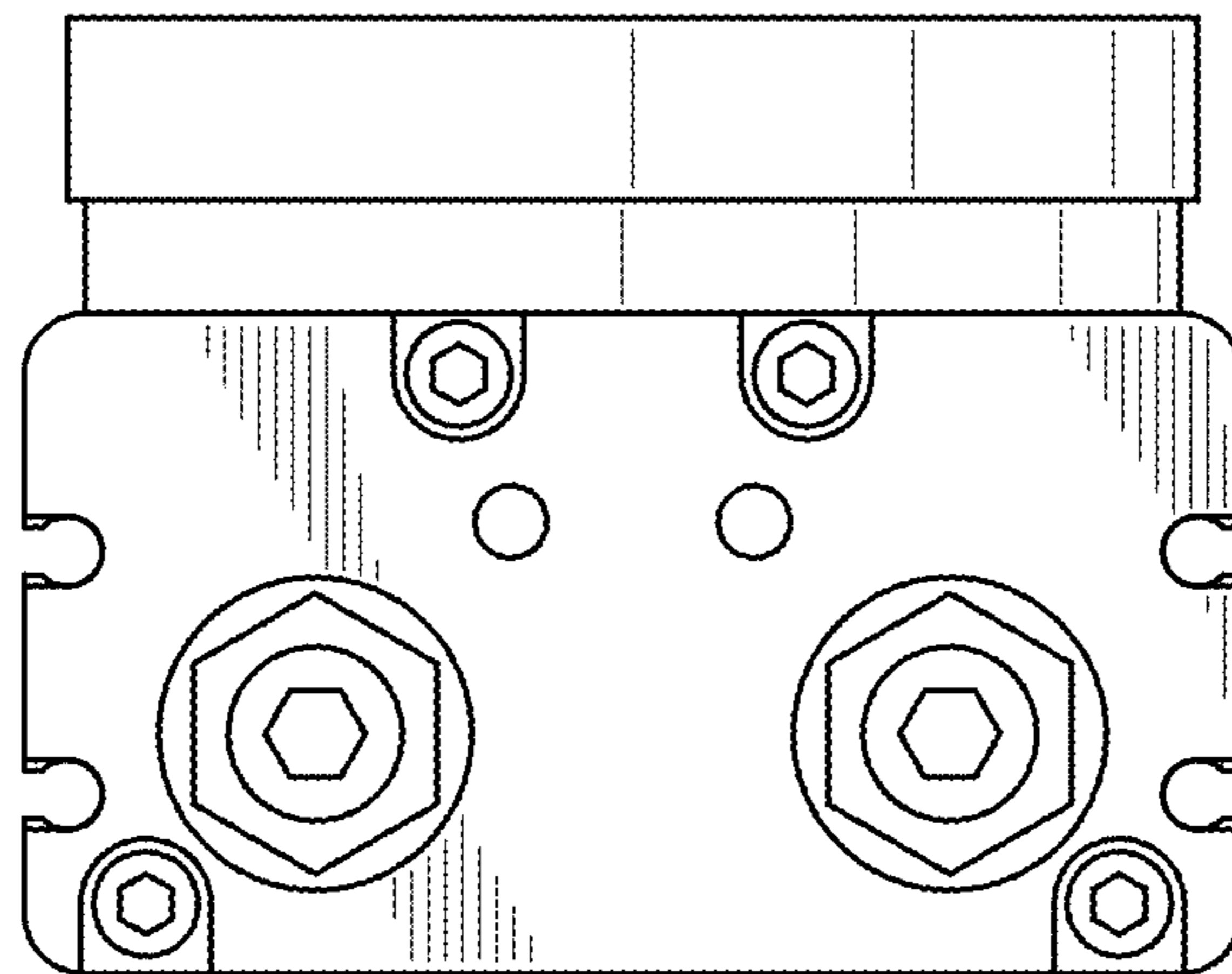

FIG. 16

