



US00D824967S

(12) **United States Design Patent**  
**Getto et al.**

(10) **Patent No.:** **US D824,967 S**

(45) **Date of Patent:** **\*\* Aug. 7, 2018**

(54) **BEARING WITH INTEGRAL DIVERTED LANTERN RING FOR A ROTARY MECHANICAL DEVICE**

(71) Applicant: **SEAL RYT CORPORATION**,  
Westfield, MA (US)

(72) Inventors: **Andrew J. Getto**, Agawam, MA (US);  
**Michael F. Huard**, Easthampton, MA (US)

(73) Assignee: **SEAL RYT CORPORATION**,  
Westfield, MA (US)

(\*\*) Term: **15 Years**

(21) Appl. No.: **29/583,834**

(22) Filed: **Nov. 9, 2016**

**Related U.S. Application Data**

(63) Continuation-in-part of application No. 14/935,897,  
filed on Nov. 9, 2015.

(51) **LOC (11) Cl.** ..... **15-09**

(52) **U.S. Cl.**  
USPC ..... **D15/143**

(58) **Field of Classification Search**  
USPC ..... D15/143  
CPC ..... F04D 29/10; F04D 29/043; F04D 29/049;  
F04D 29/053; F04D 29/059  
See application file for complete search history.

(56) **References Cited**

**U.S. PATENT DOCUMENTS**

D28,868 S *	6/1898	Keiper .....	D15/143
D28,869 S *	6/1898	Perkins .....	D15/143
D29,522 S *	10/1898	Cummings .....	D15/143
D30,182 S *	2/1899	Creager .....	D15/143
D30,183 S *	2/1899	Creager .....	D15/143
2,321,927 A	6/1943	McCoy et al.	
D214,338 S *	6/1969	Stone .....	D15/143

3,646,846 A	3/1972	Houghton et al.	
D258,828 S *	4/1981	Zrobek .....	D15/143
4,298,207 A	11/1981	Hopper et al.	
4,301,893 A	11/1981	St. Jean et al.	
4,371,180 A	2/1983	Case et al.	
4,431,698 A	2/1984	Case et al.	
4,559,862 A	12/1985	Case et al.	
D330,208 S *	10/1992	Hawley .....	D15/143
5,370,926 A	12/1994	Hopper	
5,518,302 A *	5/1996	Bernoni .....	B60B 37/00 301/105.1

(Continued)

**FOREIGN PATENT DOCUMENTS**

DE 3028537 A1 2/1981

*Primary Examiner* — Patricia A Palasik

(74) *Attorney, Agent, or Firm* — Michael I. Wolfson;  
William H. Dippert

(57) **CLAIM**

The ornamental design for a bearing with integral diverted lantern ring for a rotary mechanical device, as shown and described.

**DESCRIPTION**

FIG. 1 is a top perspective view of a bearing with integral diverted lantern ring for a rotary mechanical device showing our new design;  
FIG. 2 is a bottom perspective view of a bearing with integral diverted lantern ring for a rotary mechanical device showing our new design;  
FIG. 3 is a front elevational view thereof;  
FIG. 4 is a right side elevational view thereof;  
FIG. 5 is a left side elevational view thereof;  
FIG. 6 is a rear elevational view thereof;  
FIG. 7 is a top plan view thereof;  
FIG. 8 is a bottom plan view thereof; and,  
FIG. 9 is a top perspective view of the two halves of a bearing showing our new design.

**1 Claim, 5 Drawing Sheets**

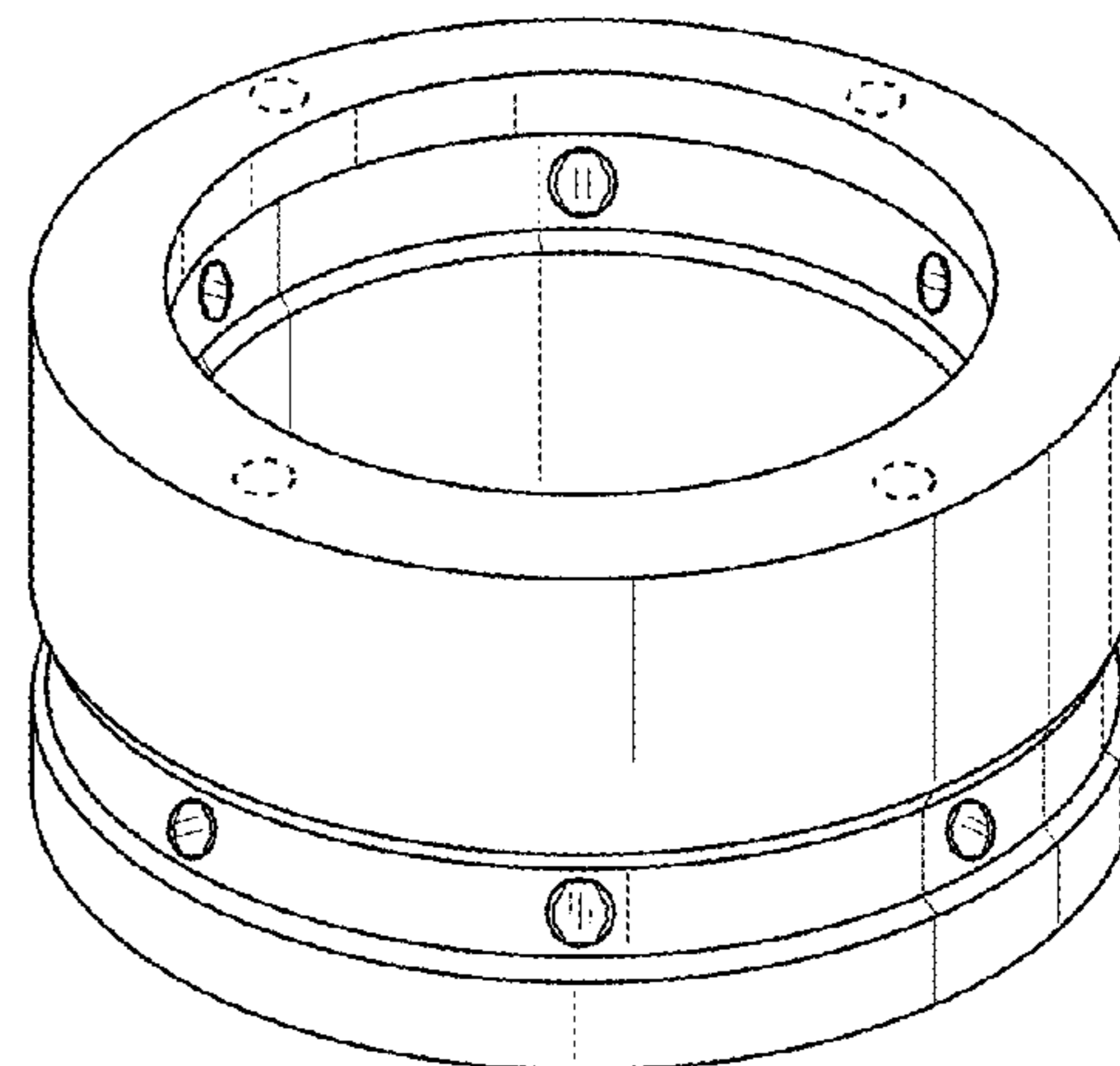
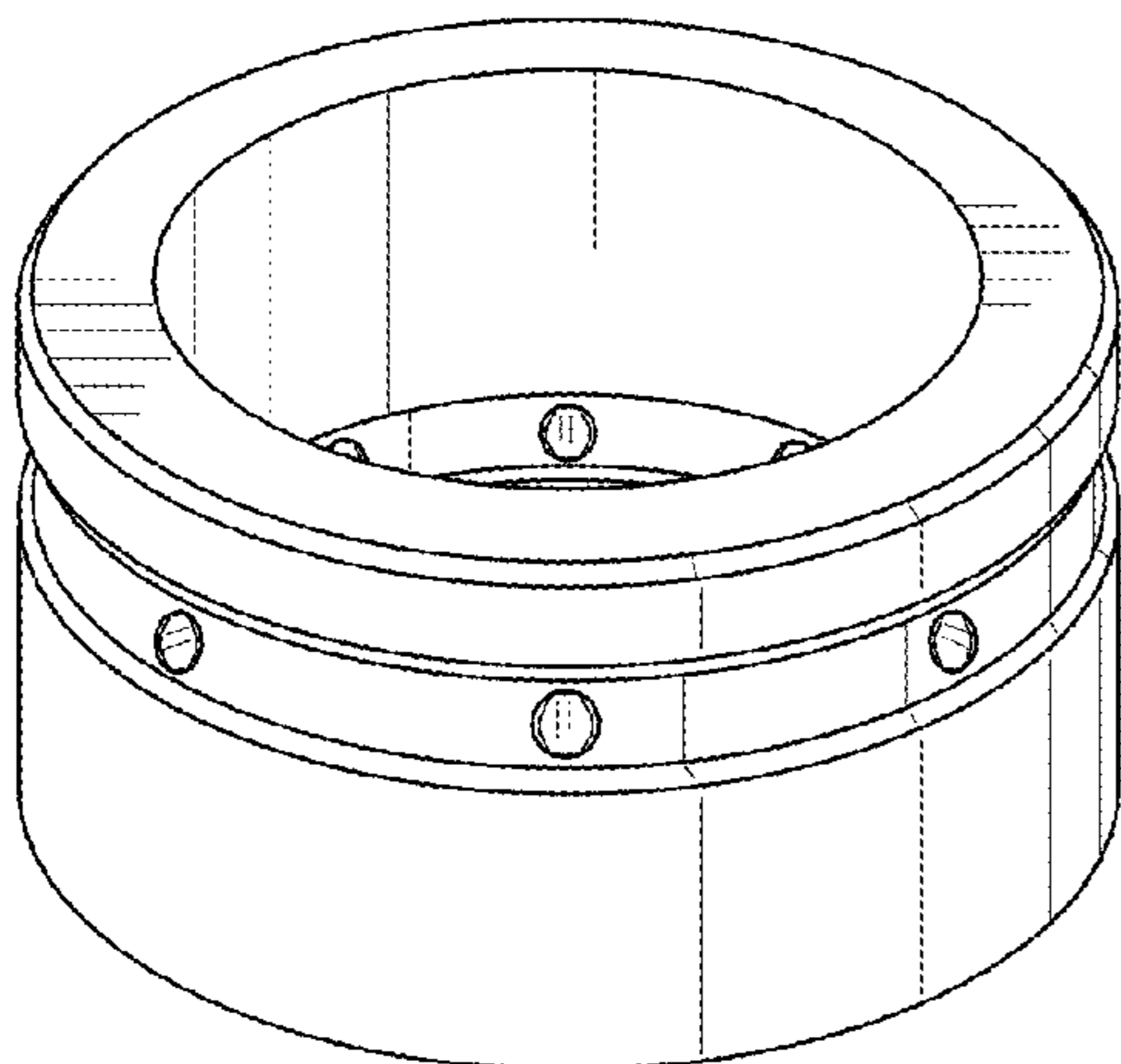

(56)

References Cited

U.S. PATENT DOCUMENTS

D371,138 S *	6/1996	Waskiewicz	384/428	9,347,488 B2	5/2016	Thoma et al.	
D372,254 S *	7/1996	Hirayama	D15/143	D768,217 S *	10/2016	Yamamoto	D15/143
D379,999 S *	6/1997	Benson	D15/143	D768,743 S *	10/2016	Yamamoto	D15/143
D380,959 S *	7/1997	Mitchell	D15/143	D770,547 S *	11/2016	Yamamoto	D15/143
D390,855 S *	2/1998	Benson	D15/143	D771,166 S *	11/2016	Koganei	D15/143
D420,688 S *	2/2000	Ichihara	D15/143	D772,964 S *	11/2016	Ban	D15/143
6,082,721 A *	7/2000	Kingsley	F16B 11/008 267/276	9,556,907 B2 *	1/2017	Shimizu	F16C 33/4635
D436,022 S *	1/2001	Arnold	D8/358	9,664,231 B2 *	5/2017	Omoto	F16C 33/56
D436,117 S *	1/2001	Chuang	D15/143	D789,186 S *	6/2017	Sakai	D8/374
D443,627 S *	6/2001	West	D15/143	9,677,617 B2 *	6/2017	Karlsson	F16C 33/6614
D444,802 S *	7/2001	Dyson	D15/143	9,901,807 B2 *	2/2018	Su	A63C 17/017
6,442,817 B1 *	9/2002	Swanson	B25B 27/06 29/275	2003/0026718 A1	2/2003	Dziver et al.	
6,834,862 B2	12/2004	Wilkinson		2003/0039418 A1 *	2/2003	Lee	F16C 21/00 384/126
D519,535 S *	4/2006	Olsson	D15/143	2003/0091251 A1 *	5/2003	Ni	F16C 33/08 384/295
D638,454 S *	5/2011	Torii	D15/143	2003/0107183 A1	6/2003	Wilkinson	
D649,986 S *	12/2011	Fujikata	D15/138	2006/0006592 A1 *	1/2006	Kato	F16F 13/1445 267/140.12
D659,175 S *	5/2012	Fujikata	D15/138	2006/0117898 A1 *	6/2006	Schneider	B62D 1/185 74/492
D660,890 S *	5/2012	Ito	D15/143	2008/0112658 A1 *	5/2008	Justin	F16C 17/02 384/107
D679,301 S	4/2013	Wilkinson		2010/0166347 A1 *	7/2010	Wendling	F16C 33/1075 384/114
D679,302 S	4/2013	Wilkinson		2012/0076575 A1 *	3/2012	Smith	B23P 11/00 403/289
D695,788 S	12/2013	Wilkinson		2014/0115822 A1 *	5/2014	Shishido	F16L 5/02 16/2.1
D699,272 S *	2/2014	Mochizuki	D15/143	2017/0130729 A1 *	5/2017	Getto	F04D 29/043
8,814,432 B2	8/2014	Thoma et al.		2017/0146065 A1 *	5/2017	Danowski	F16C 17/10
D713,434 S *	9/2014	Nishikawa	D15/143				
D719,821 S *	12/2014	McGrath	D8/382				
9,062,710 B2 *	6/2015	Lee	F16C 19/381				
D736,284 S *	8/2015	Maurer	D15/143				
9,206,903 B2	12/2015	Huard et al.					

\* cited by examiner

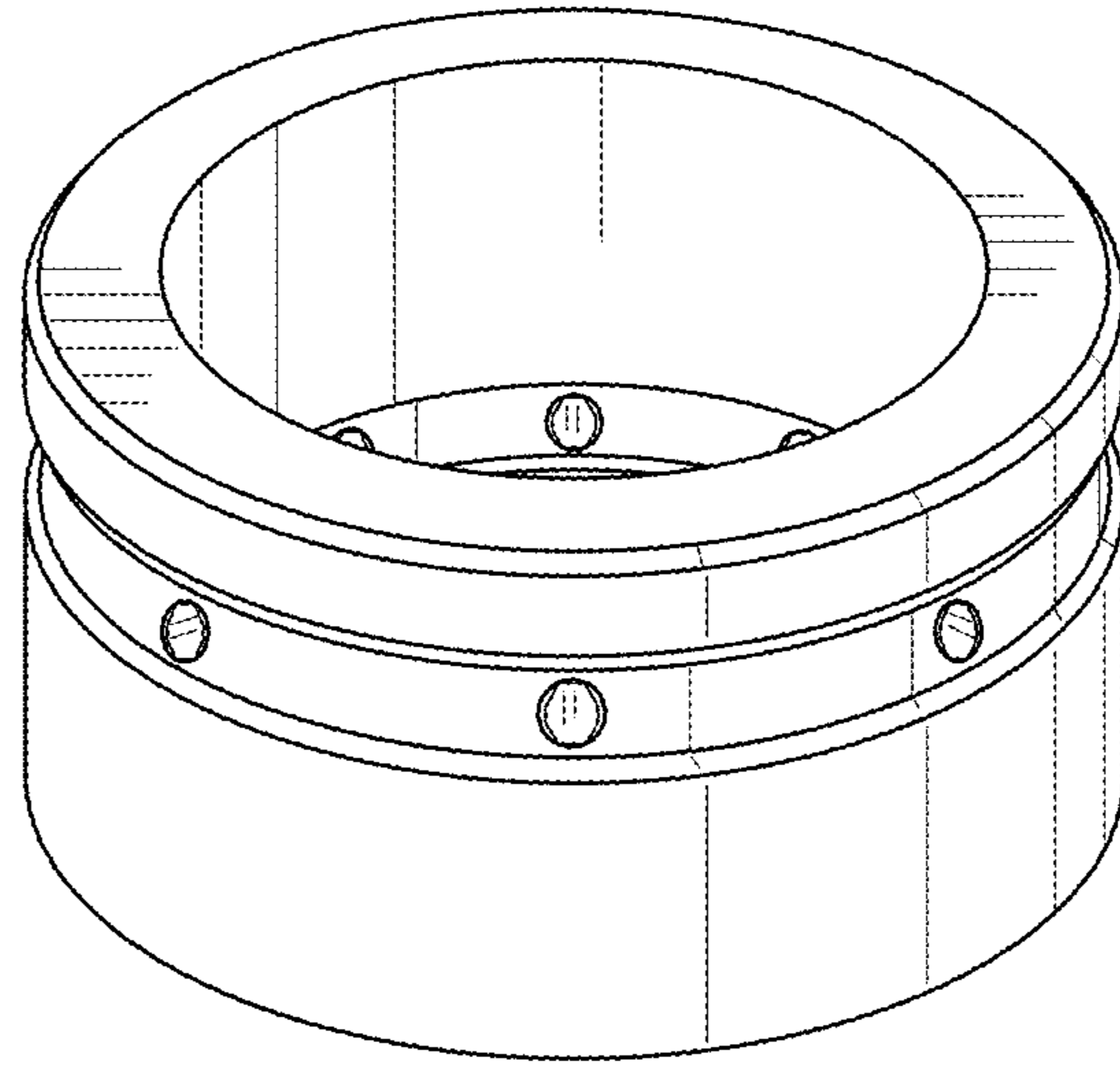

FIG. 1

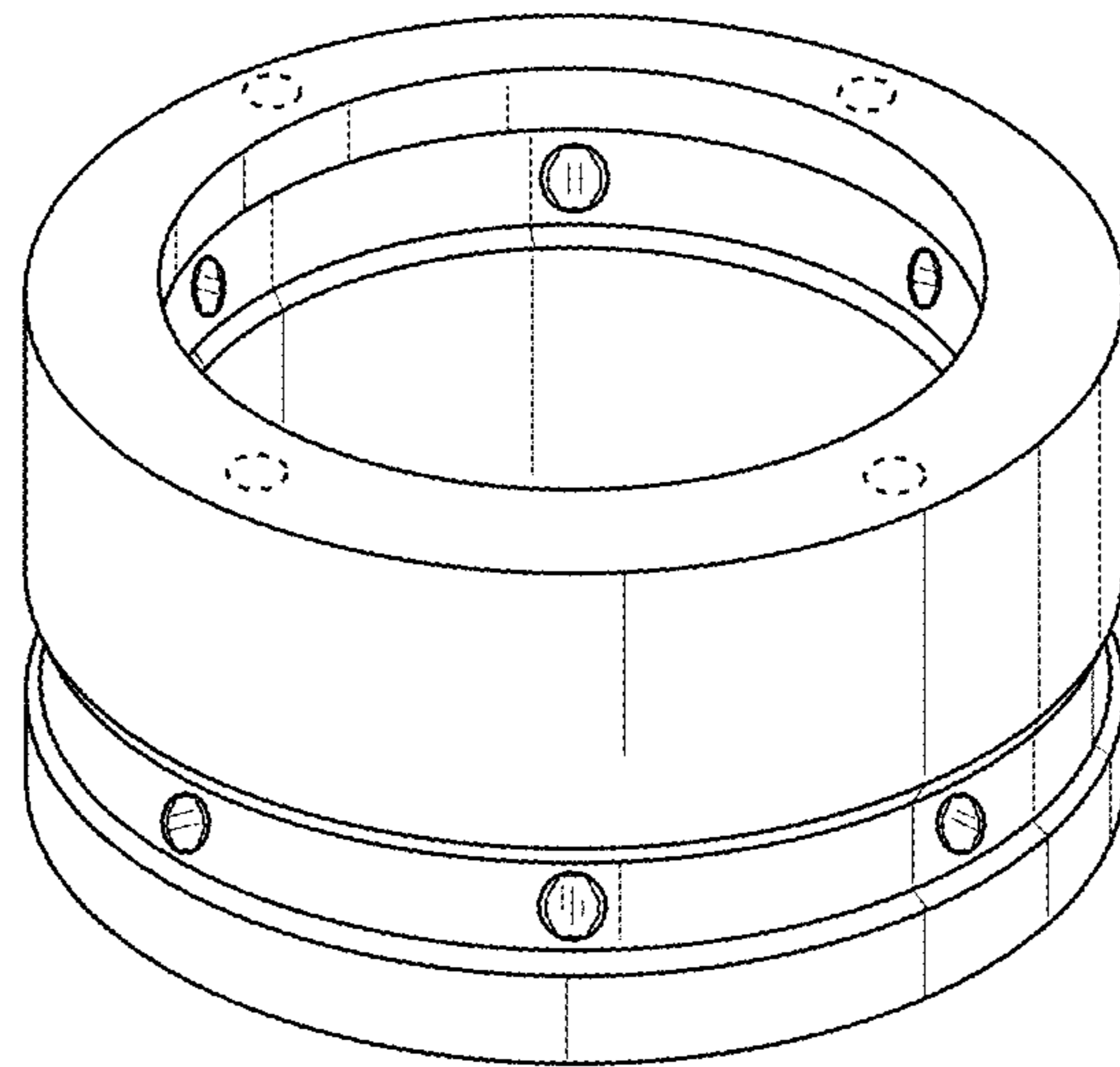

FIG. 2

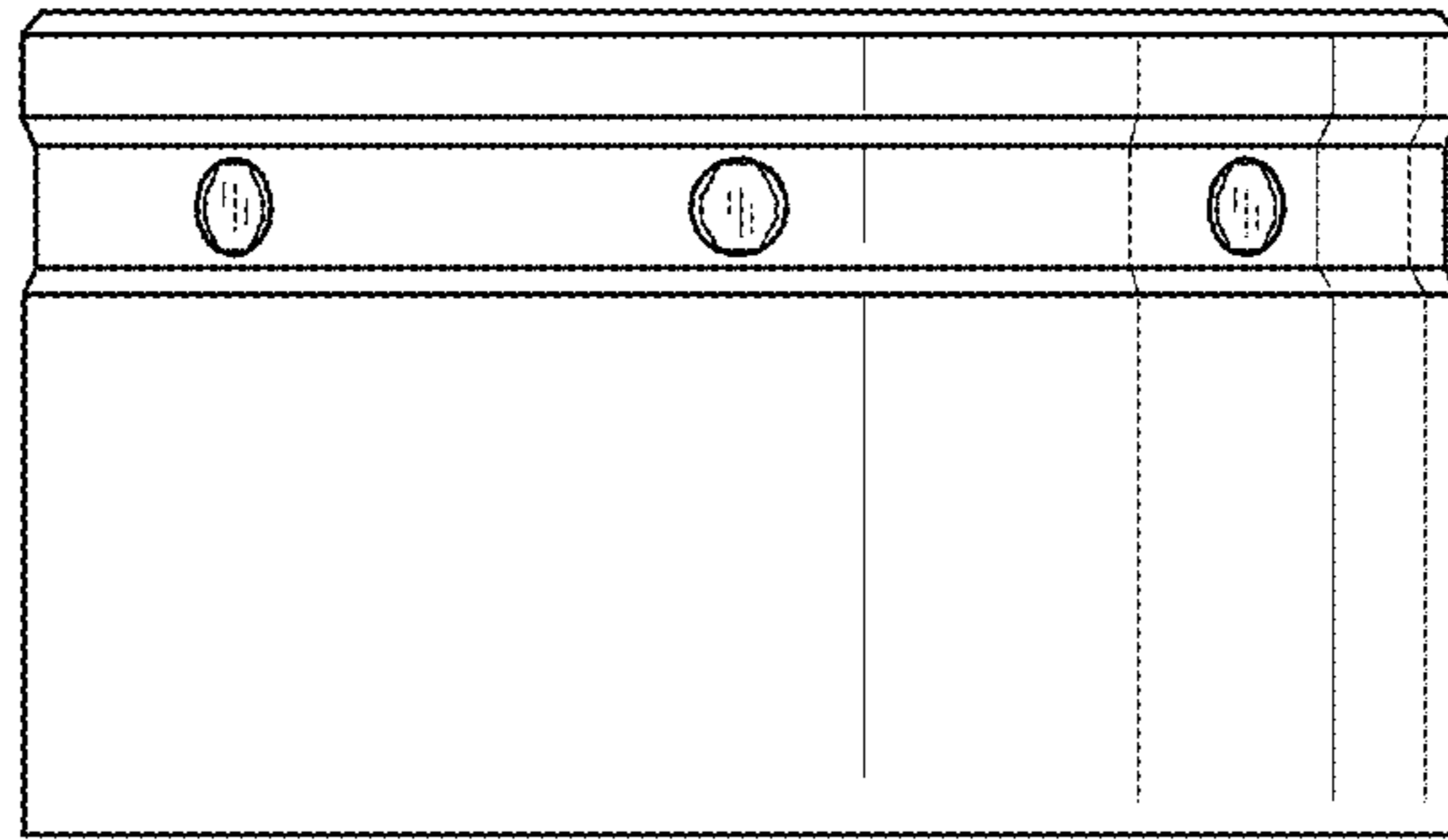

FIG. 3

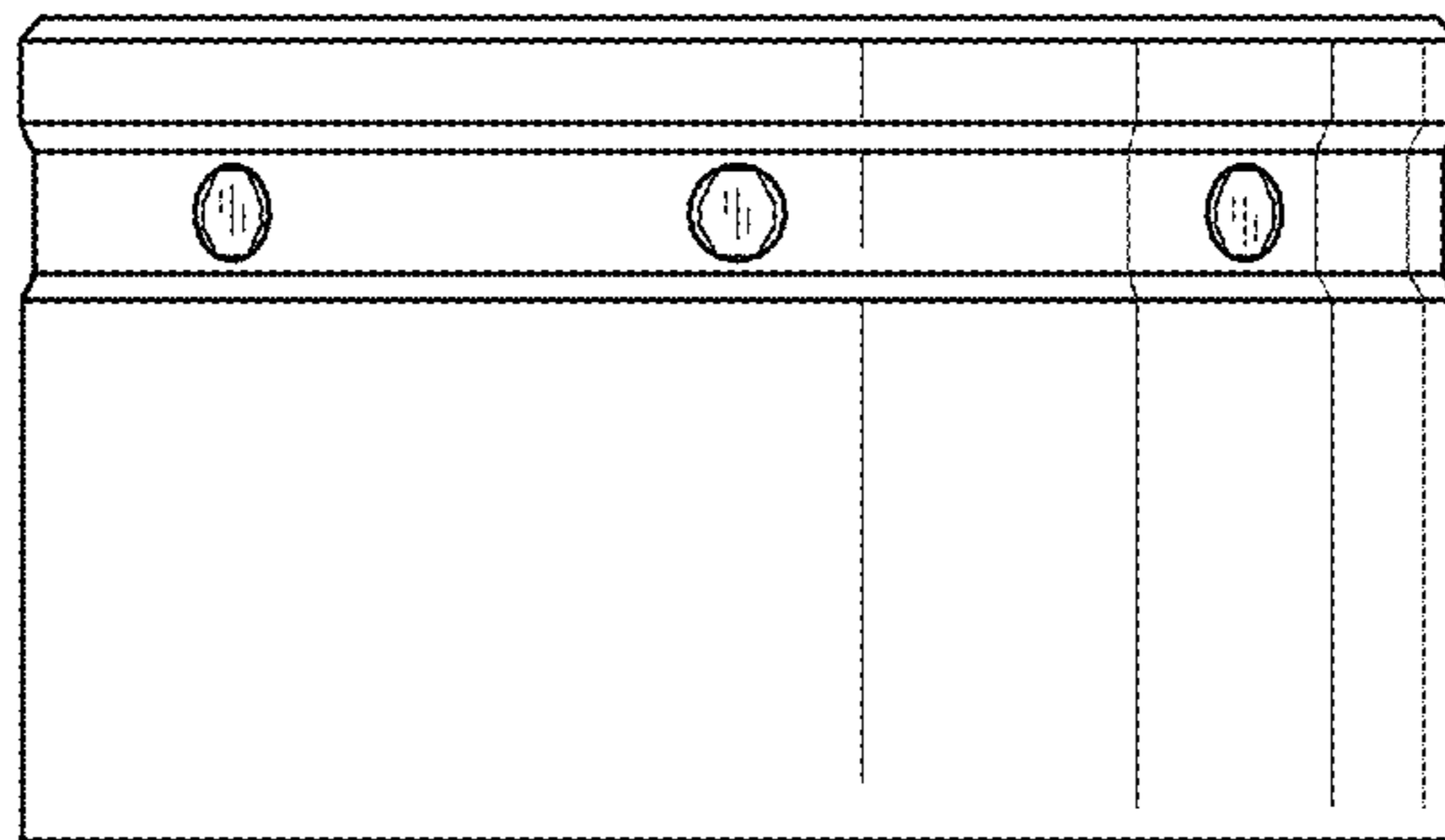

FIG. 4

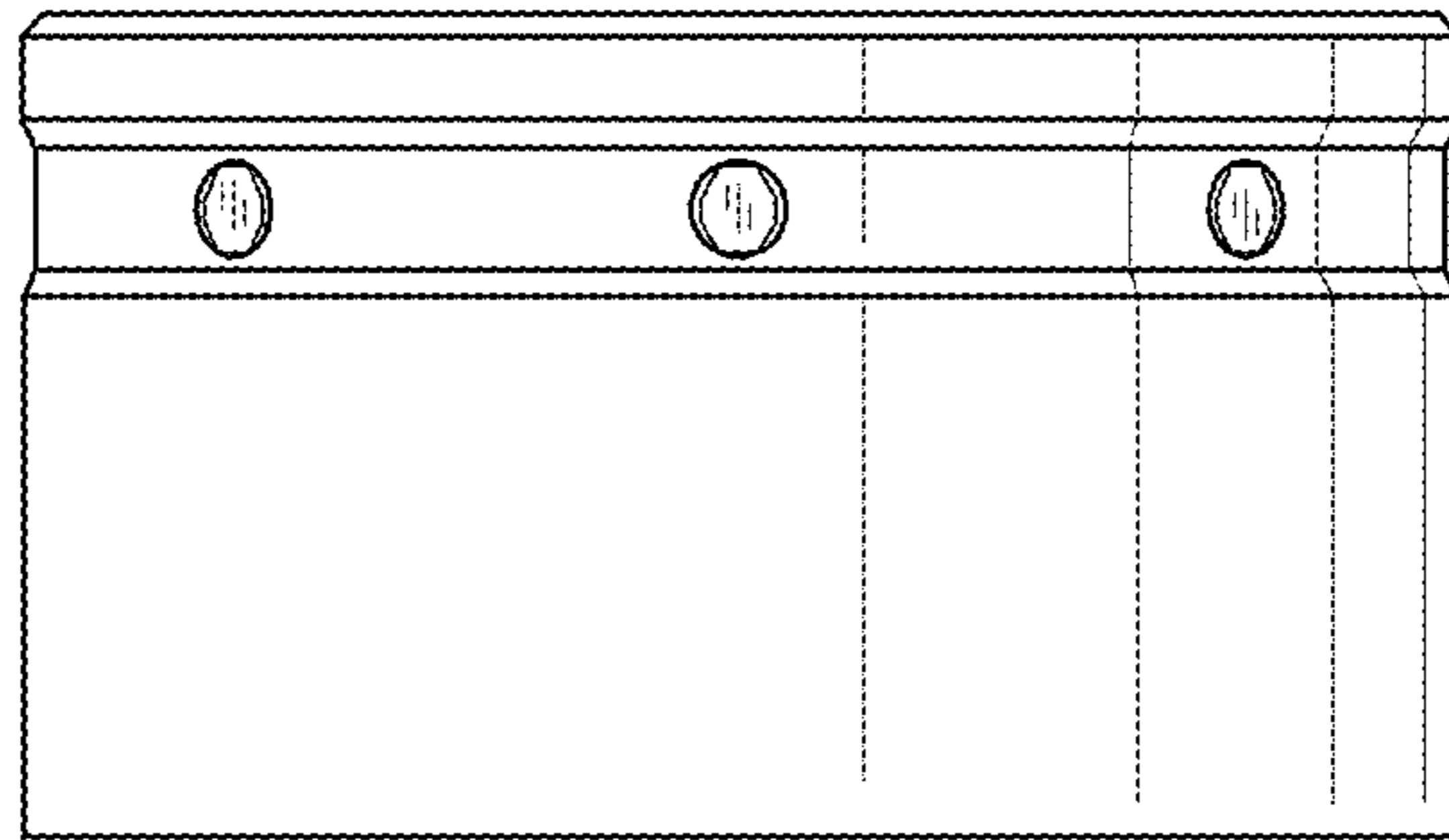

FIG. 5

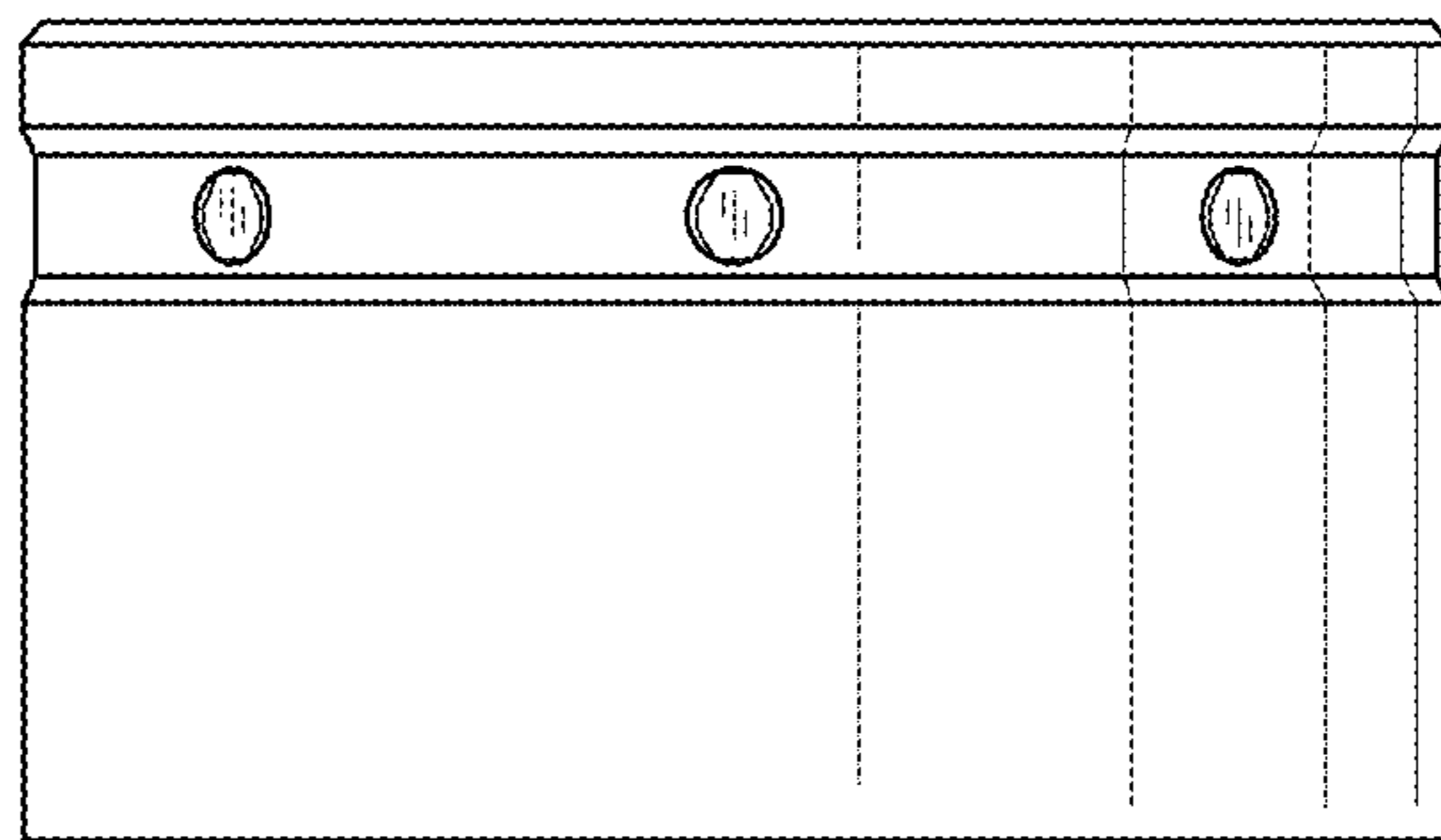

FIG. 6

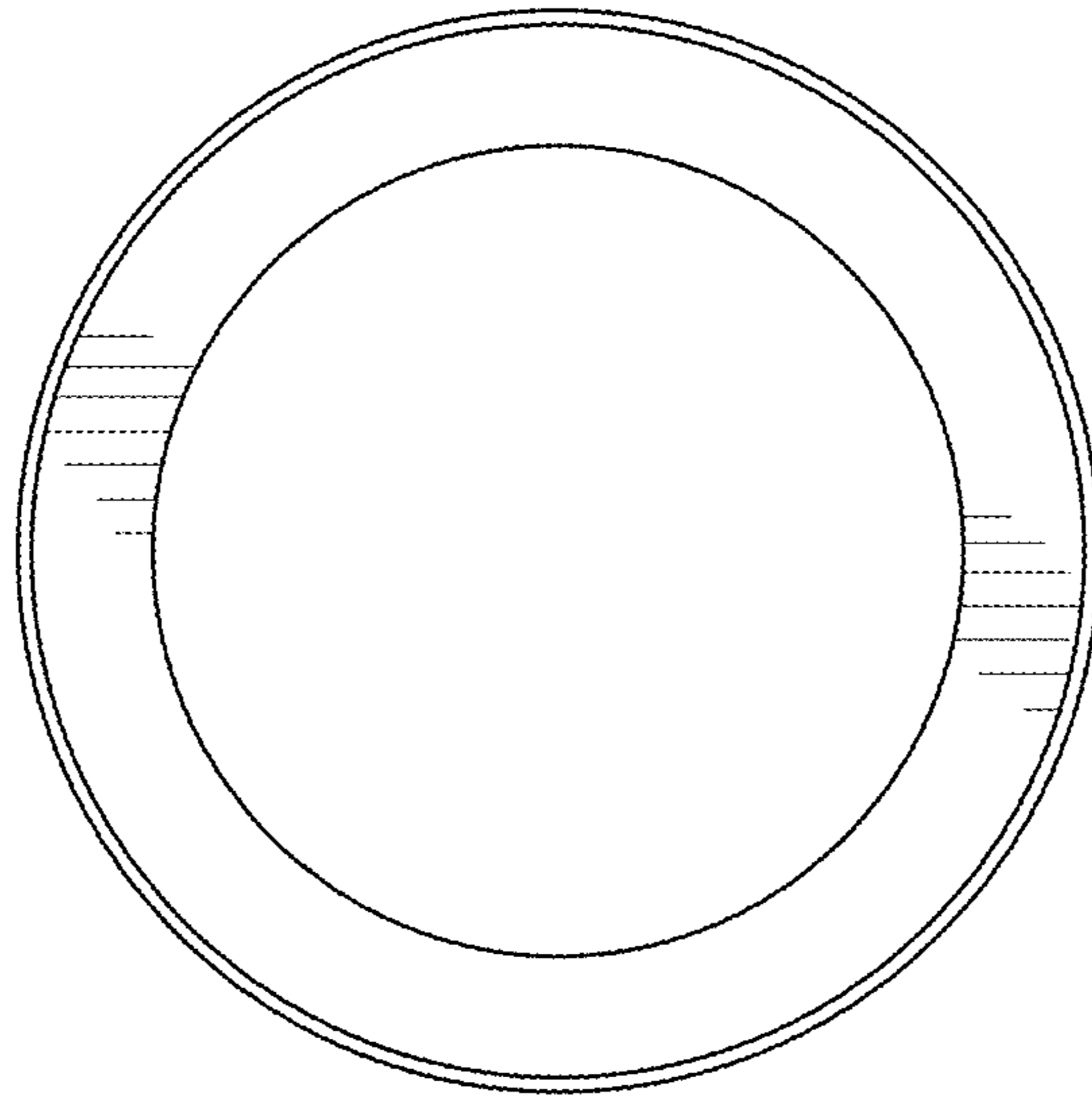

FIG. 7

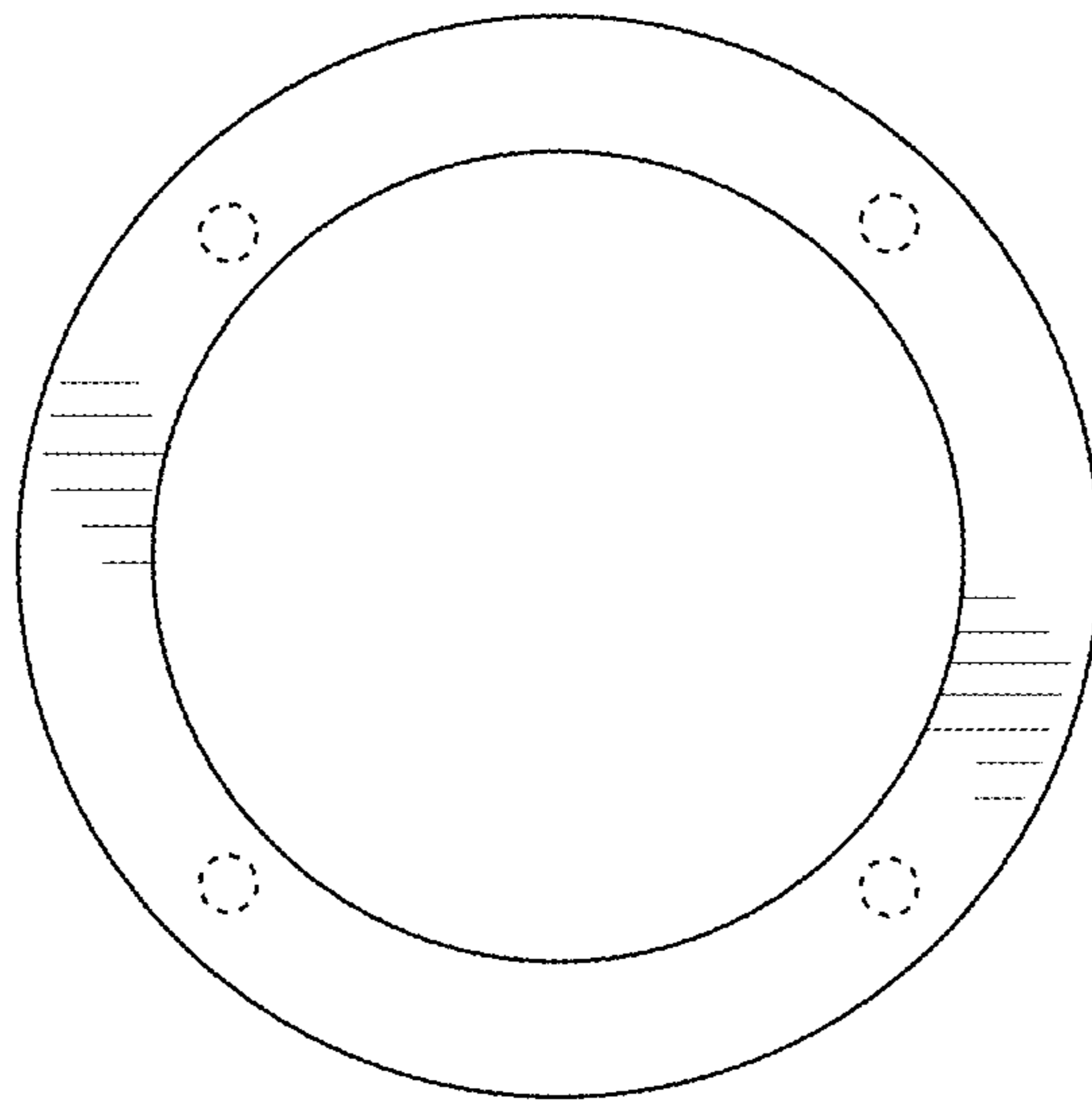

FIG. 8

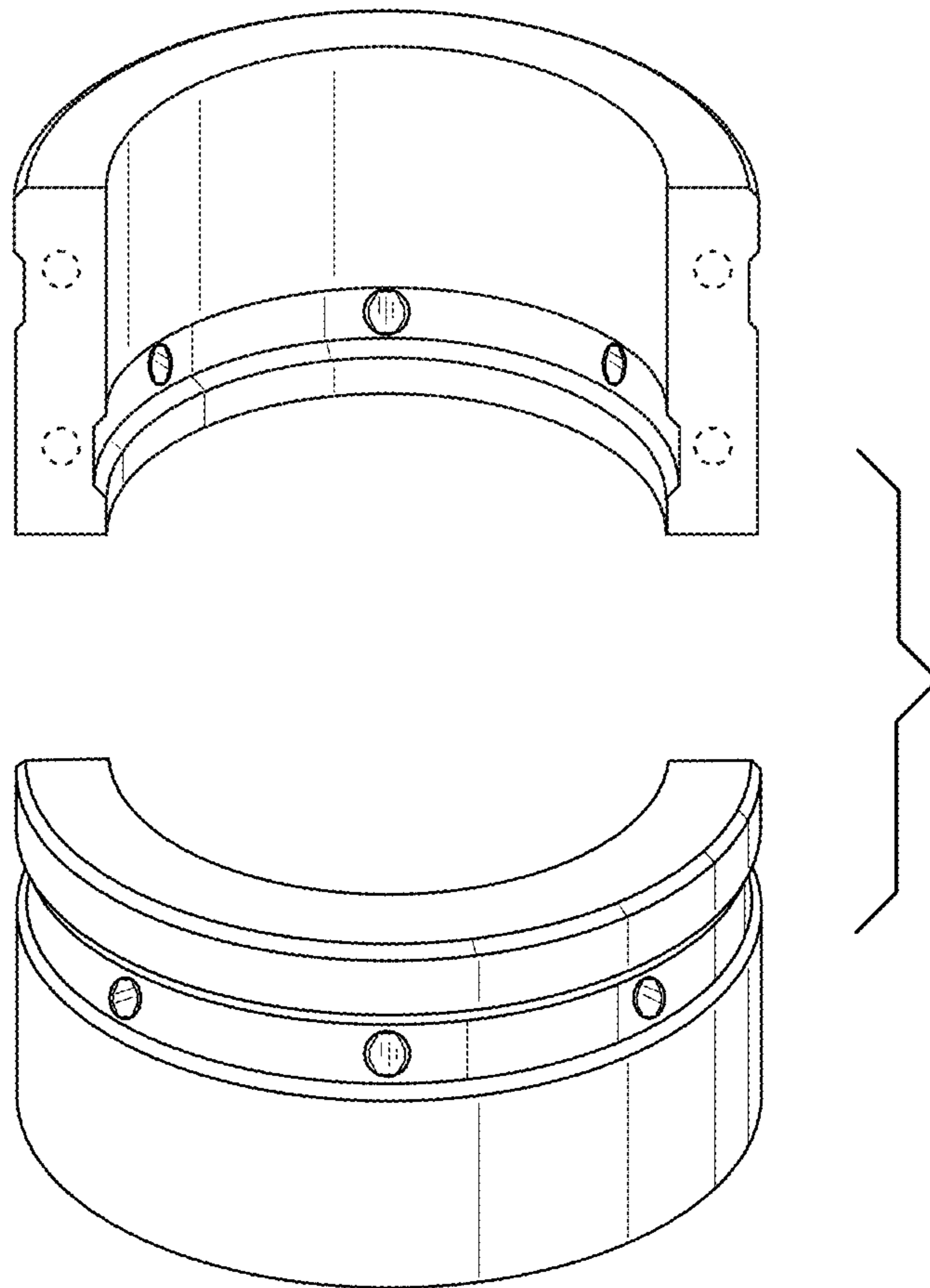

FIG. 9