



US00D824845S

(12) **United States Design Patent** (10) **Patent No.:** **US D824,845 S**
Iwamura (45) **Date of Patent:** **** Aug. 7, 2018**

(54) **TIRE**
(71) Applicant: **SUMITOMO RUBBER INDUSTRIES, LTD.**, Hyogo (JP)
(72) Inventor: **Wako Iwamura**, Kobe (JP)
(73) Assignee: **SUMITOMO RUBBER INDUSTRIES, LTD.**, Kobe-Shi, Hyogo (JP)

D501,445 S * 2/2005 Brayer D12/553
D502,141 S * 2/2005 Marazzi D12/553
D502,443 S * 3/2005 Kuramochi D12/549
D503,373 S * 3/2005 Marazzi D12/553
D503,374 S * 3/2005 Maxwell D12/553
D514,059 S * 1/2006 Dixon D12/552
D537,406 S * 2/2007 Reim D12/555
D548,678 S * 8/2007 Welbes D12/553
D598,367 S * 8/2009 de Briey-Terlinden D12/553

(Continued)

(**) Term: **15 Years**
(21) Appl. No.: **35/501,740**
(22) Filed: **Apr. 21, 2016**

Primary Examiner — Darlington Ly
(74) Attorney, Agent, or Firm — Birch, Stewart, Kolasch & Birch, LLP

(80) **Hague Agreement Data**
Int. Filing Date: **Apr. 21, 2016**
Int. Reg. No.: **DM/091740**
Int. Reg. Date: **Apr. 21, 2016**
Int. Reg. Pub. Date: **Oct. 21, 2016**

(57) **CLAIM**
The ornamental design for a tire, as shown and described.

(30) **Foreign Application Priority Data**
Oct. 22, 2015 (JP) 2015-023458
(51) **LOC (11) Cl.** **12-15**
(52) **U.S. Cl.**
USPC **D12/605**
(58) **Field of Classification Search**
USPC D12/582, 583, 584, 585, 596, 602, 604, D12/605
CPC . B60C 11/03; B60C 11/04; B60C 2011/0344; B60C 2011/0346; B60C 2011/0374
See application file for complete search history.

DESCRIPTION

1. Tire
1.1 is a front elevation view of a tire showing my new design;
1.2 is a rear elevation view thereof;
1.3 is a right side elevation view thereof, of which the left side elevation view is a mirror image;
1.4 is a top plan view thereof, of which the bottom plan view is a mirror image;
1.5 is a front perspective view thereof;
1.6 is an enlarged front elevation view of portion 6-6 in reproduction 1.1;
1.7 is an enlarged rear elevation view of portion 7-7 in reproduction 1.1;
1.8 is an enlarged front perspective view of the portion 8-8 in reproduction 1.5;
1.9 is an enlarged cross-sectional partial view thereof taken in the direction of line 9-9 of reproduction 1.6; and
1.10 is an enlarged cross-sectional view of the radial member taken in the direction of line 10-10 of reproduction 1.6.
The broken lines in the reproductions illustrate portions of the tire that form no part of the claimed design.

(56) **References Cited**
U.S. PATENT DOCUMENTS
D451,068 S * 11/2001 Heinen D12/547
D491,129 S * 6/2004 Maxwell D12/553

1 Claim, 6 Drawing Sheets

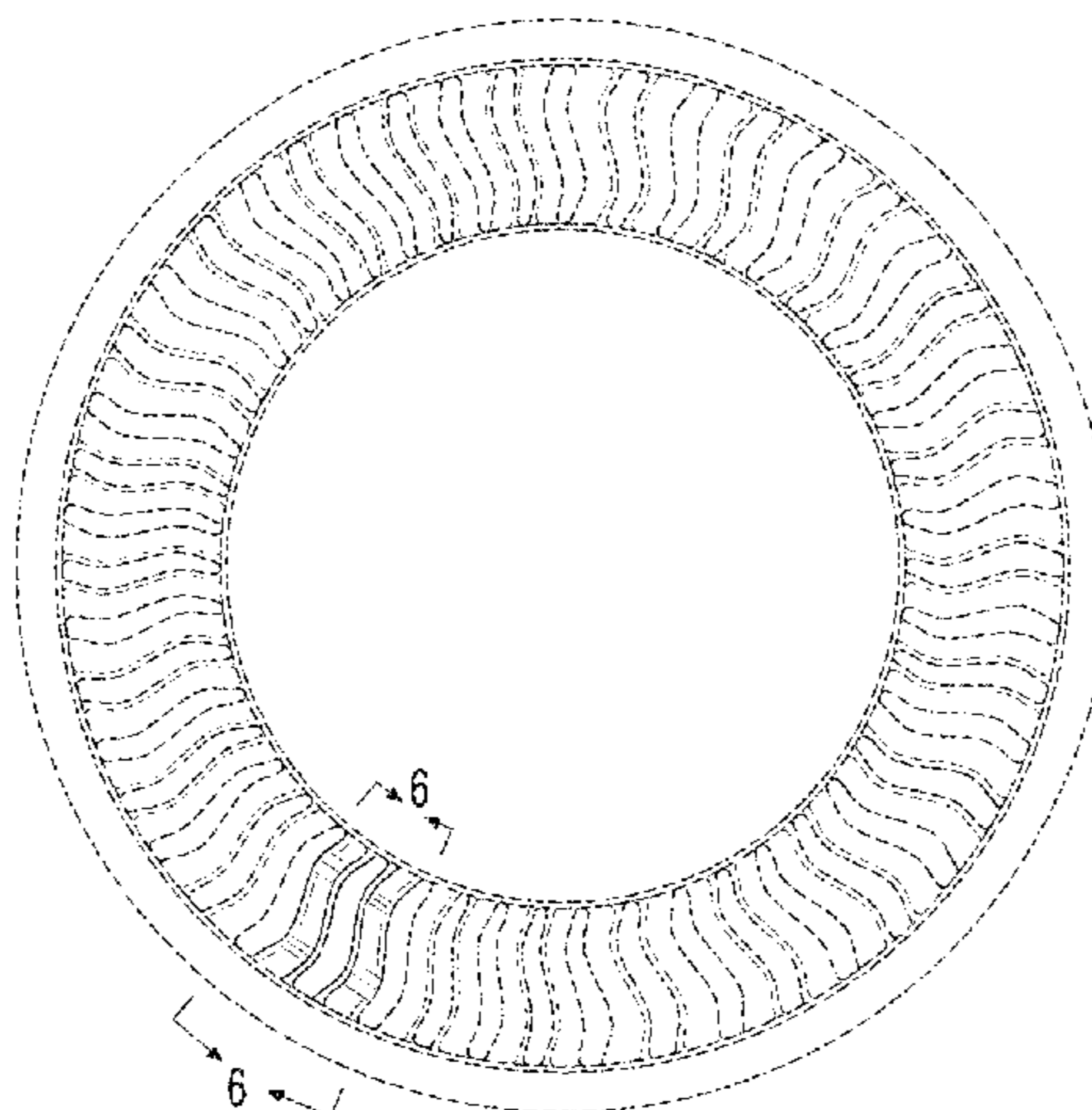

(56)

References Cited

U.S. PATENT DOCUMENTS

D641,305 S * 7/2011 De Briey-Terlinden D12/547
D644,597 S * 9/2011 Lucas D12/553

* cited by examiner

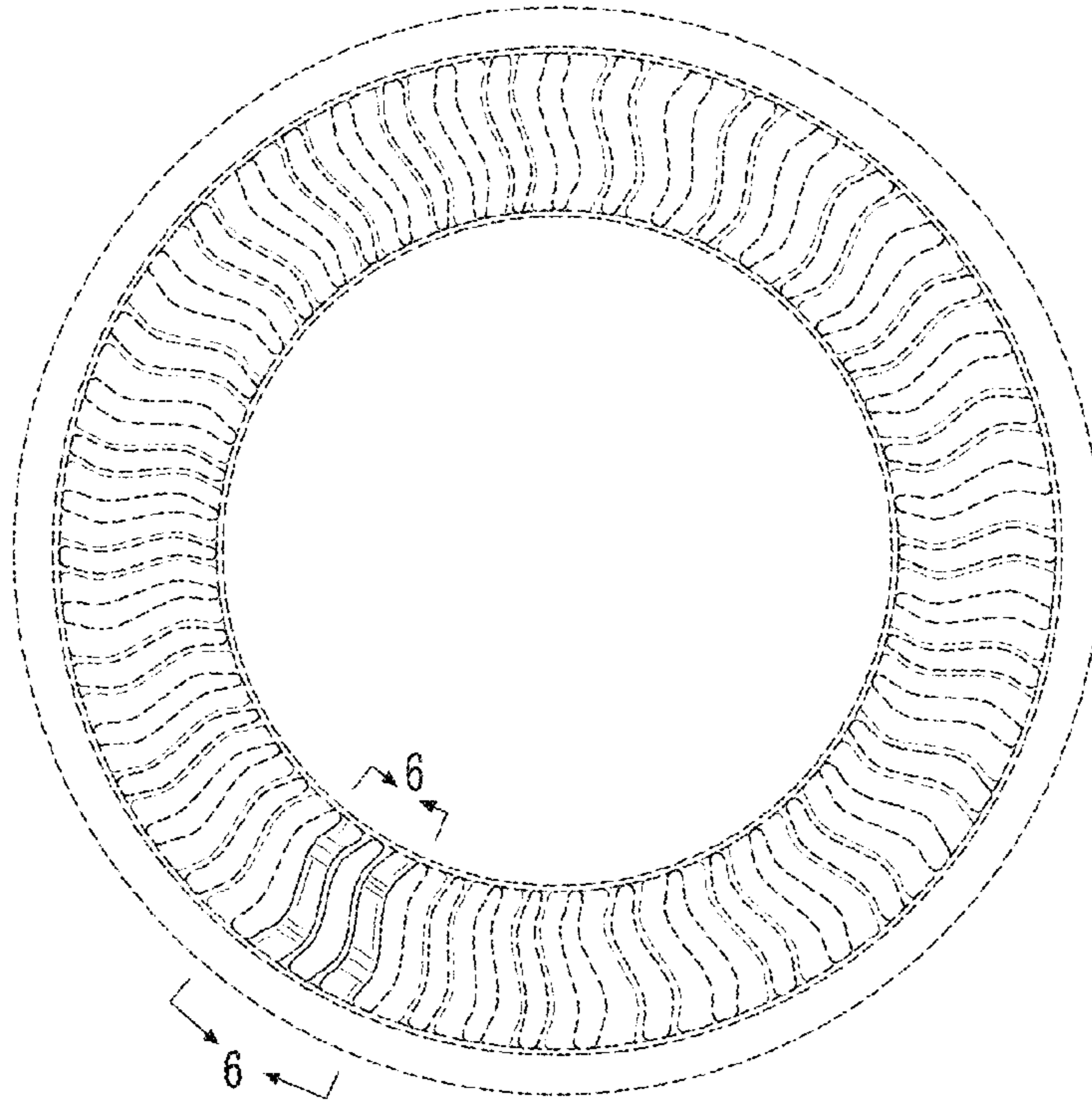

1.1

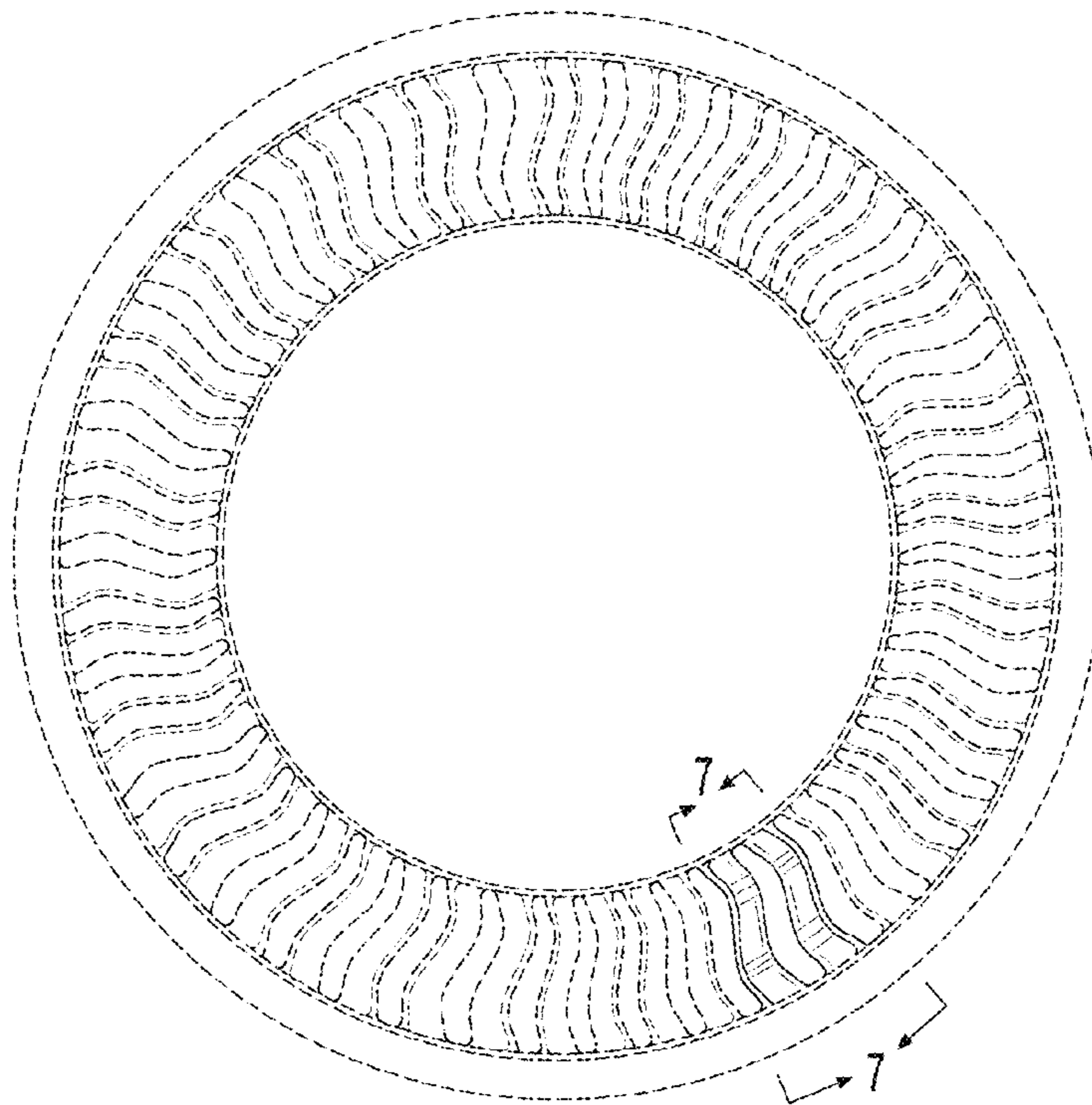

1.2

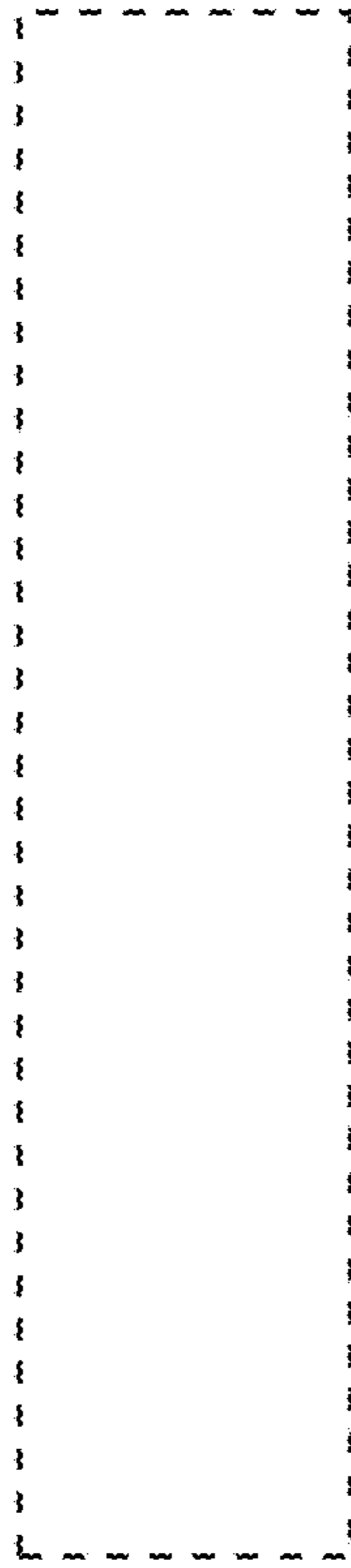

1.3



1.4

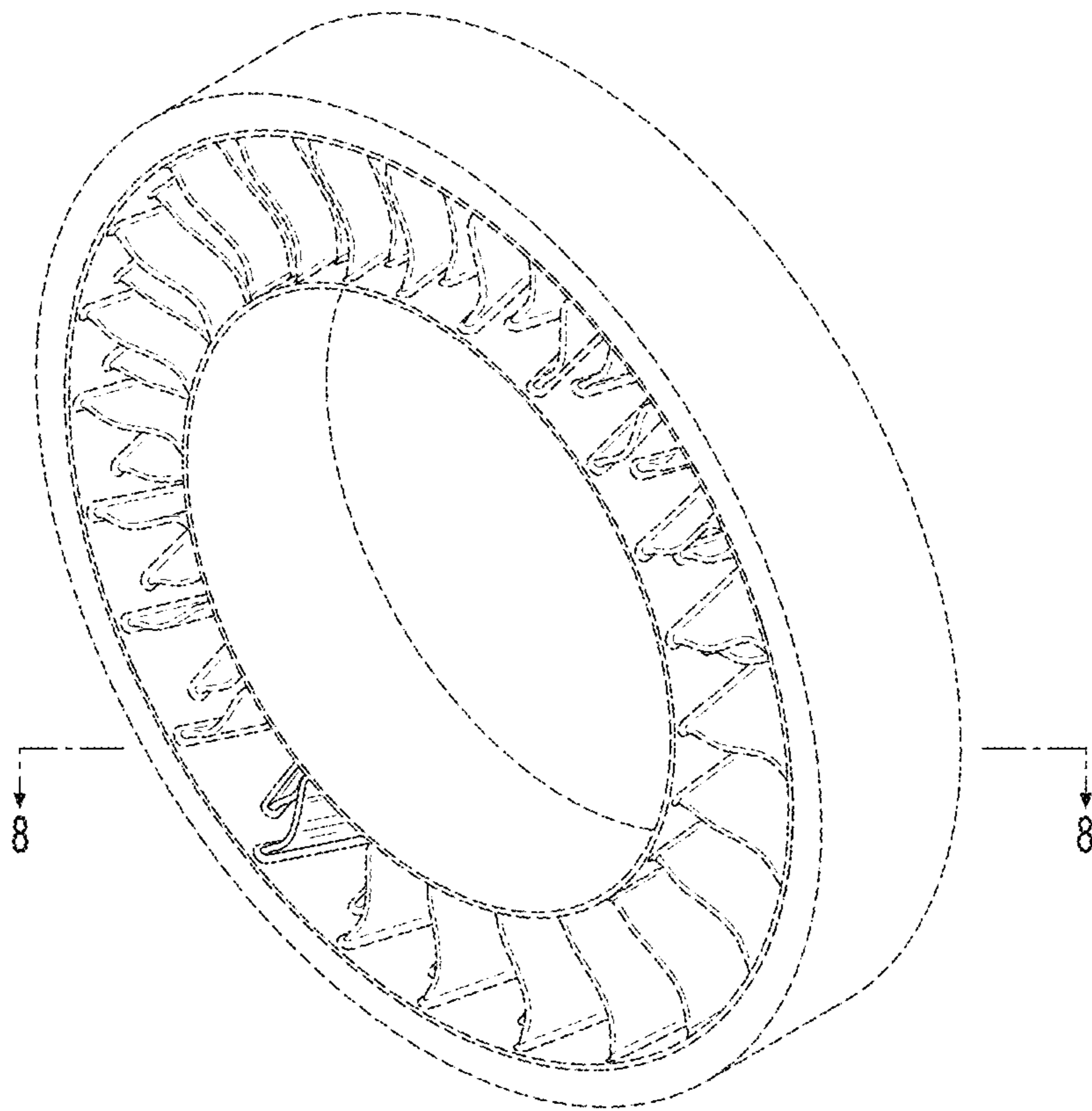

1.5

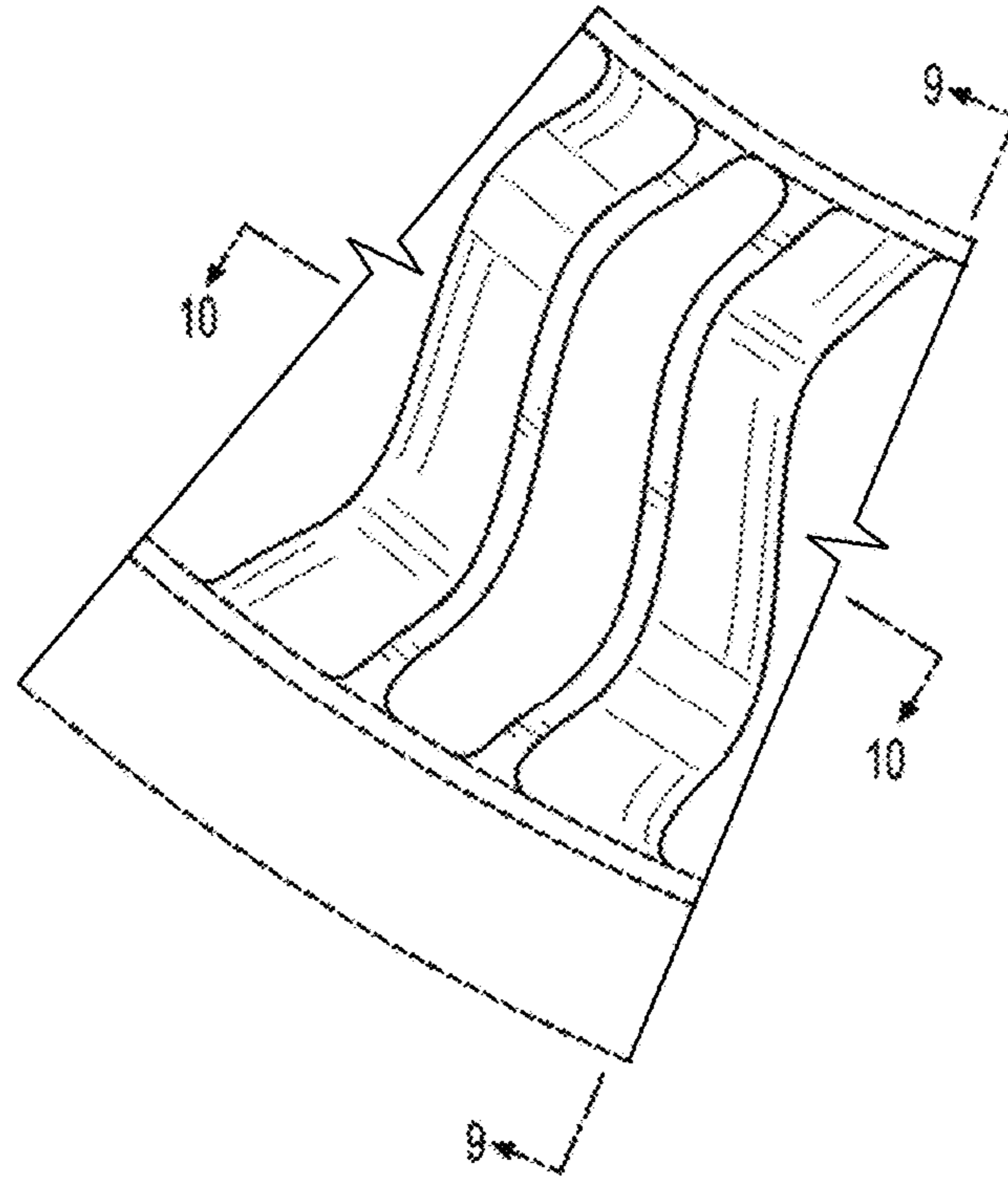

1.6

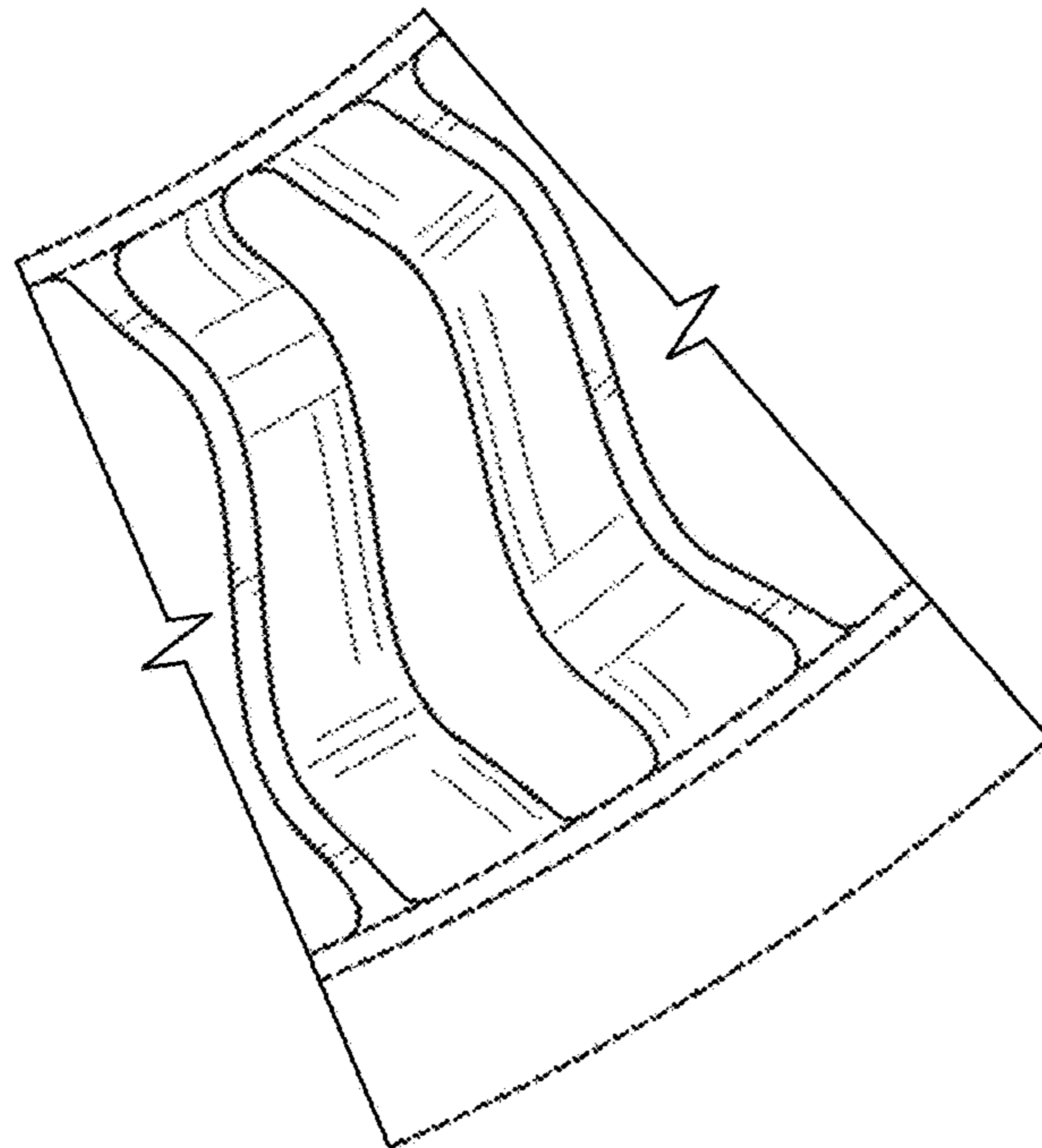

1.7

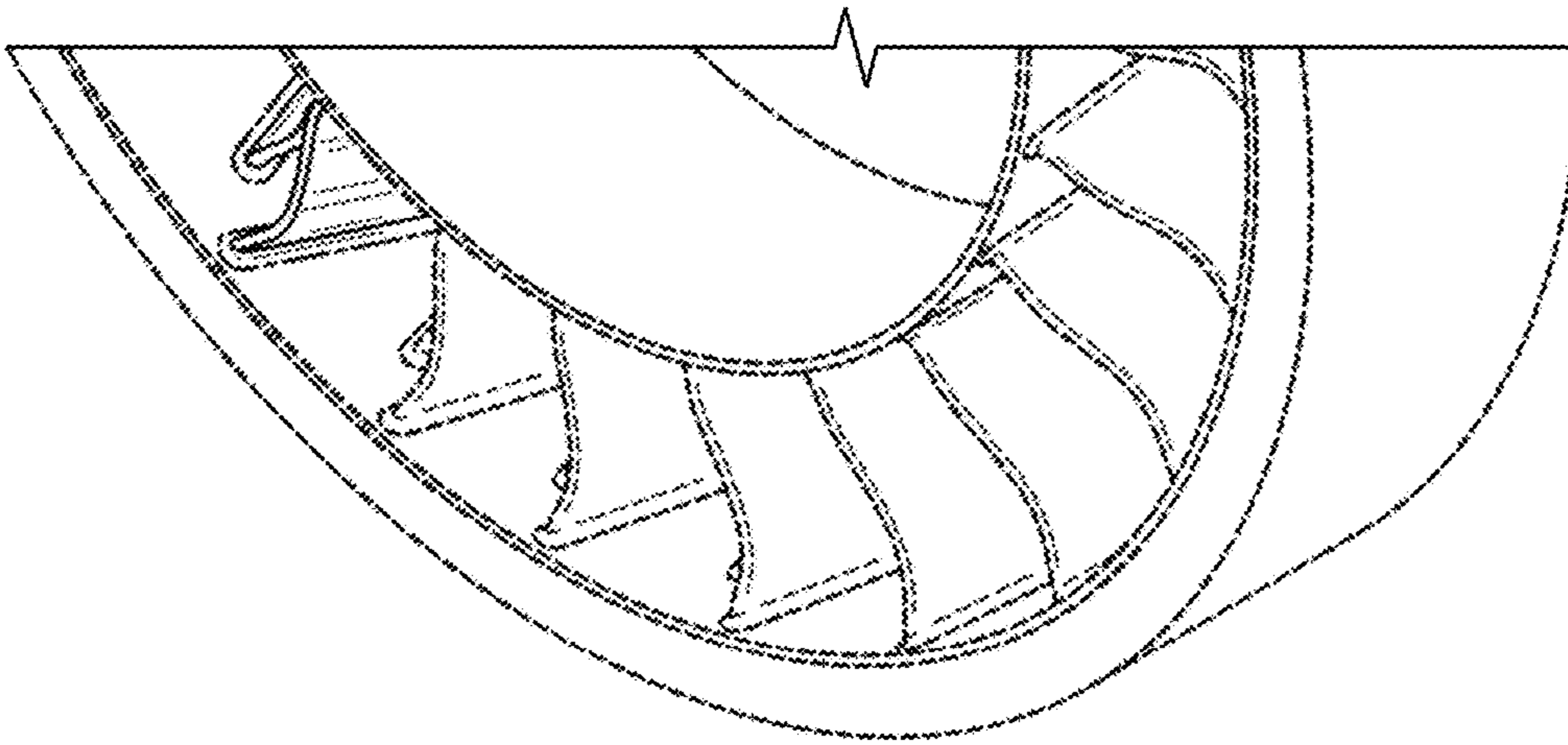

1.8

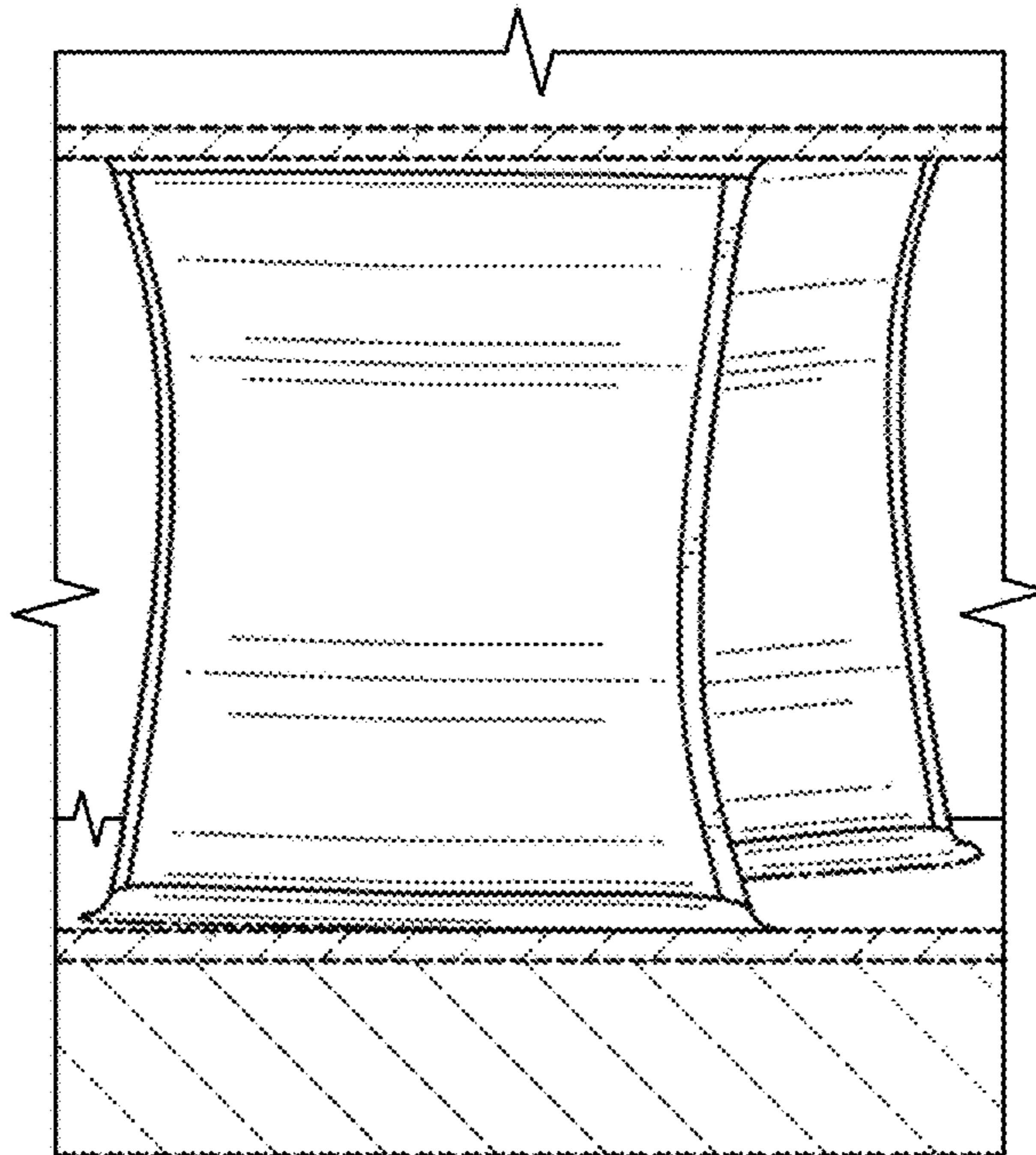

1.9

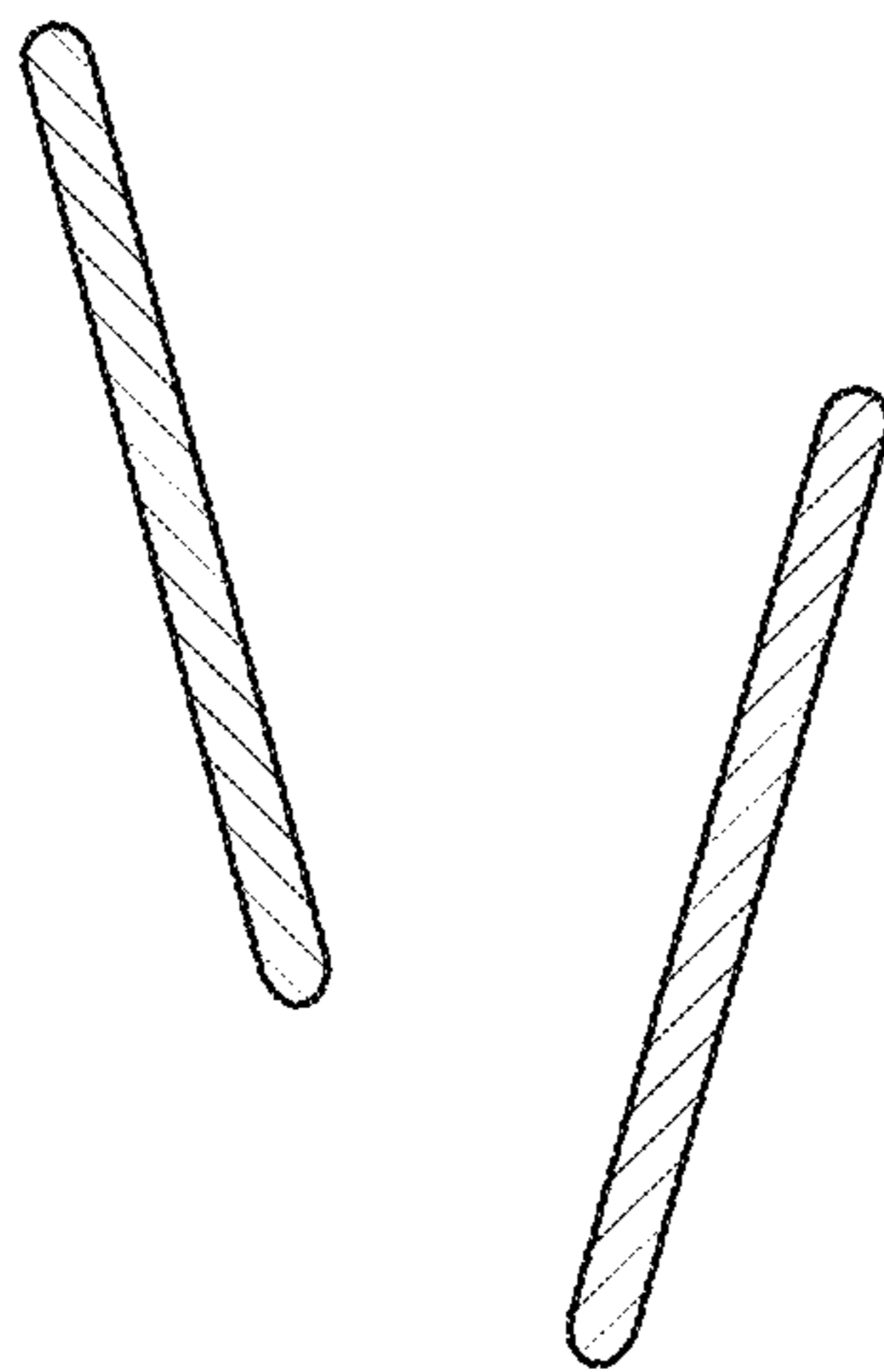

1.10