



US00D823778S

(12) **United States Design Patent**  
**Hale, Jr.**

(10) **Patent No.:** **US D823,778 S**  
(45) **Date of Patent:** **\*\* Jul. 24, 2018**

(54) **FRONT OUTWARD FLANGE OF A VEHICLE WHEEL**

(71) Applicant: **MOBILE HI-TECH WHEELS,**  
Rancho Dominguez, CA (US)

(72) Inventor: **Arthur D. Hale, Jr.,** Long Beach, CA  
(US)

(73) Assignee: **Mobile Hi-Tech Wheels,** Rancho  
Dominguez, CA (US)

(\*\*) Term: **15 Years**

(21) Appl. No.: **29/560,082**

(22) Filed: **Apr. 1, 2016**

(51) **LOC (11) Cl.** ..... **12-16**

(52) **U.S. Cl.**  
USPC ..... **D12/213**

(58) **Field of Classification Search**  
USPC ..... D12/204–213  
CPC .... B60B 7/00; B60B 7/02; B60B 7/04; B60B  
7/01; B60B 7/06; B60B 3/02; B60B 3/04;  
B60B 3/06; B60B 3/10; B60B 1/00;  
B60B 1/08; B60B 1/10; B60B 1/12  
See application file for complete search history.

(56) **References Cited**

**U.S. PATENT DOCUMENTS**

D415,089 S \* 10/1999 Schardt ..... D12/208  
D433,369 S \* 11/2000 Chung ..... D12/208

D669,412 S \* 10/2012 Le Grice ..... D12/213  
D708,114 S \* 7/2014 Hodges ..... D12/213  
D722,939 S \* 2/2015 Chung ..... D12/213  
D758,941 S \* 6/2016 Zhao ..... D12/208  
D792,831 S \* 7/2017 Chung ..... D12/213

\* cited by examiner

*Primary Examiner* — George D. Kirschbaum

(74) *Attorney, Agent, or Firm* — Lewis Roca Rothgerber  
Christie LLP

(57) **CLAIM**

The ornamental design for front outward flange of a vehicle wheel, as shown and described.

**DESCRIPTION**

FIG. 1 is a perspective view of a front outward flange of a vehicle wheel according to my new design;  
FIG. 2 is an enlarged view of the highlighted area of FIG. 1 thereof;  
FIG. 3 is a front plan view thereof;  
FIG. 4 is an enlarged view of the highlighted area of FIG. 3 thereof; and,  
FIG. 5 is a side elevational view thereof.  
The broken lines showing the side of the wheel, spokes, bolts and center cap in the central hub area are included for the purpose of illustrating environment and form no part of the claimed design.

**1 Claim, 5 Drawing Sheets**

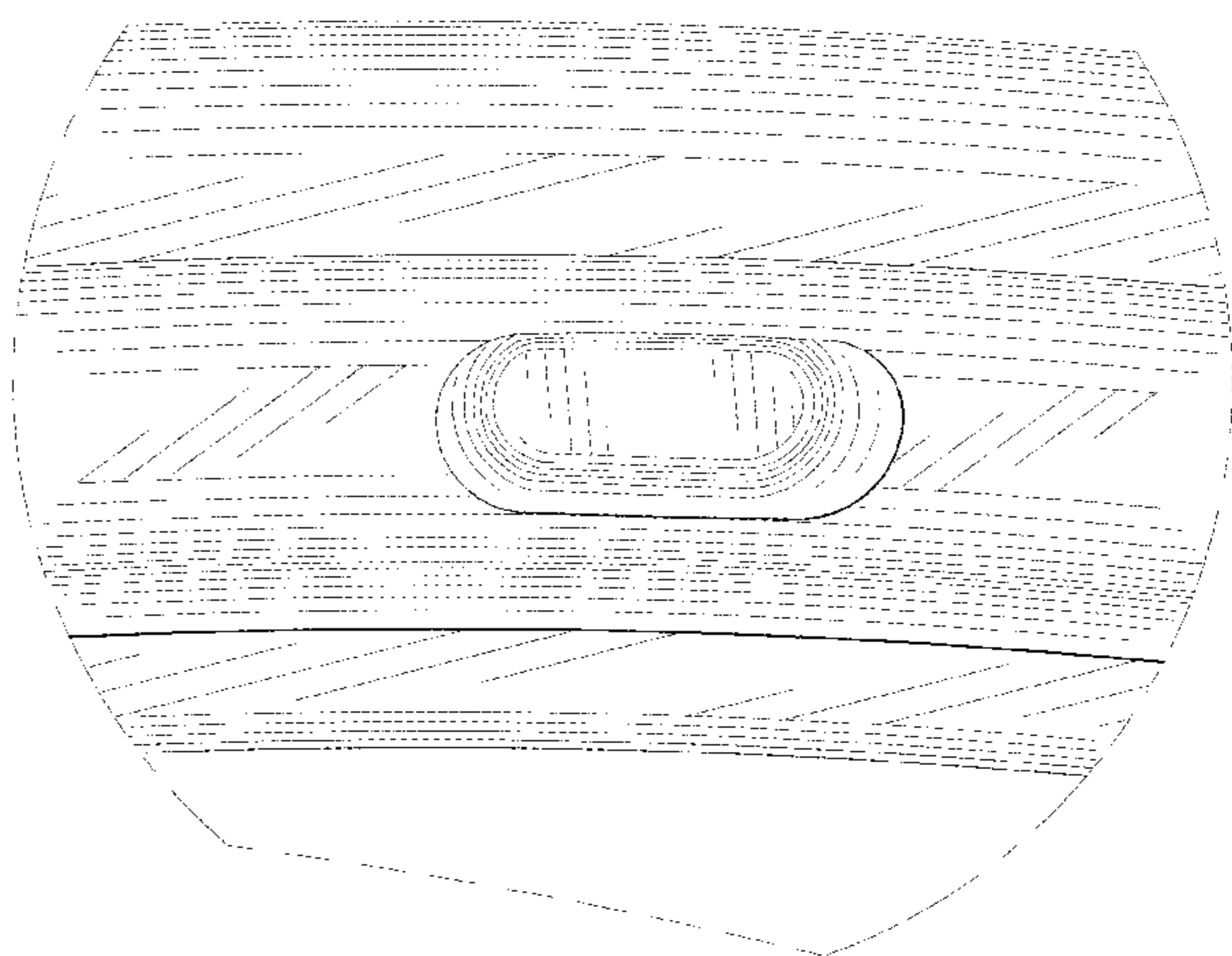
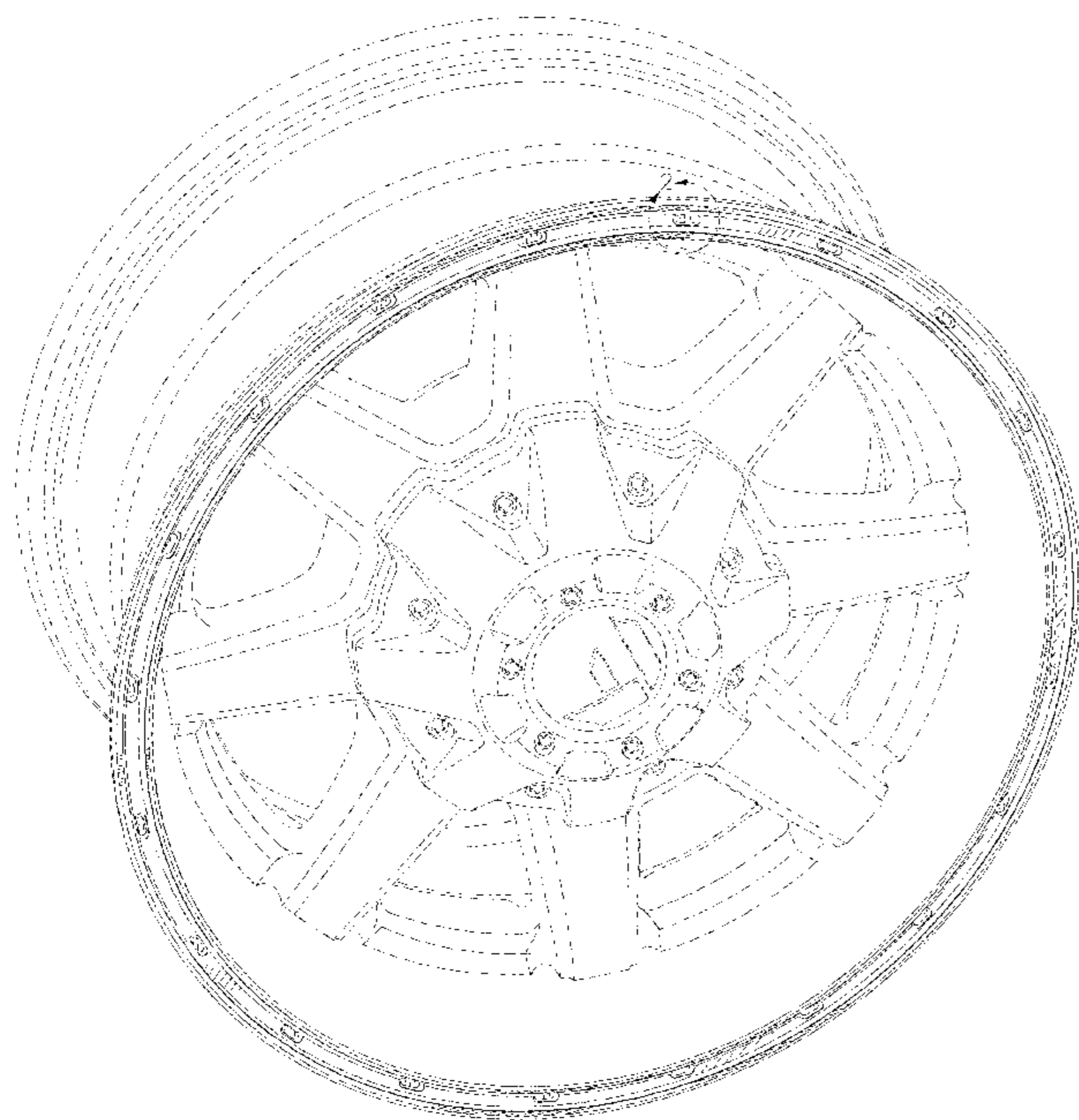

FIG. 1

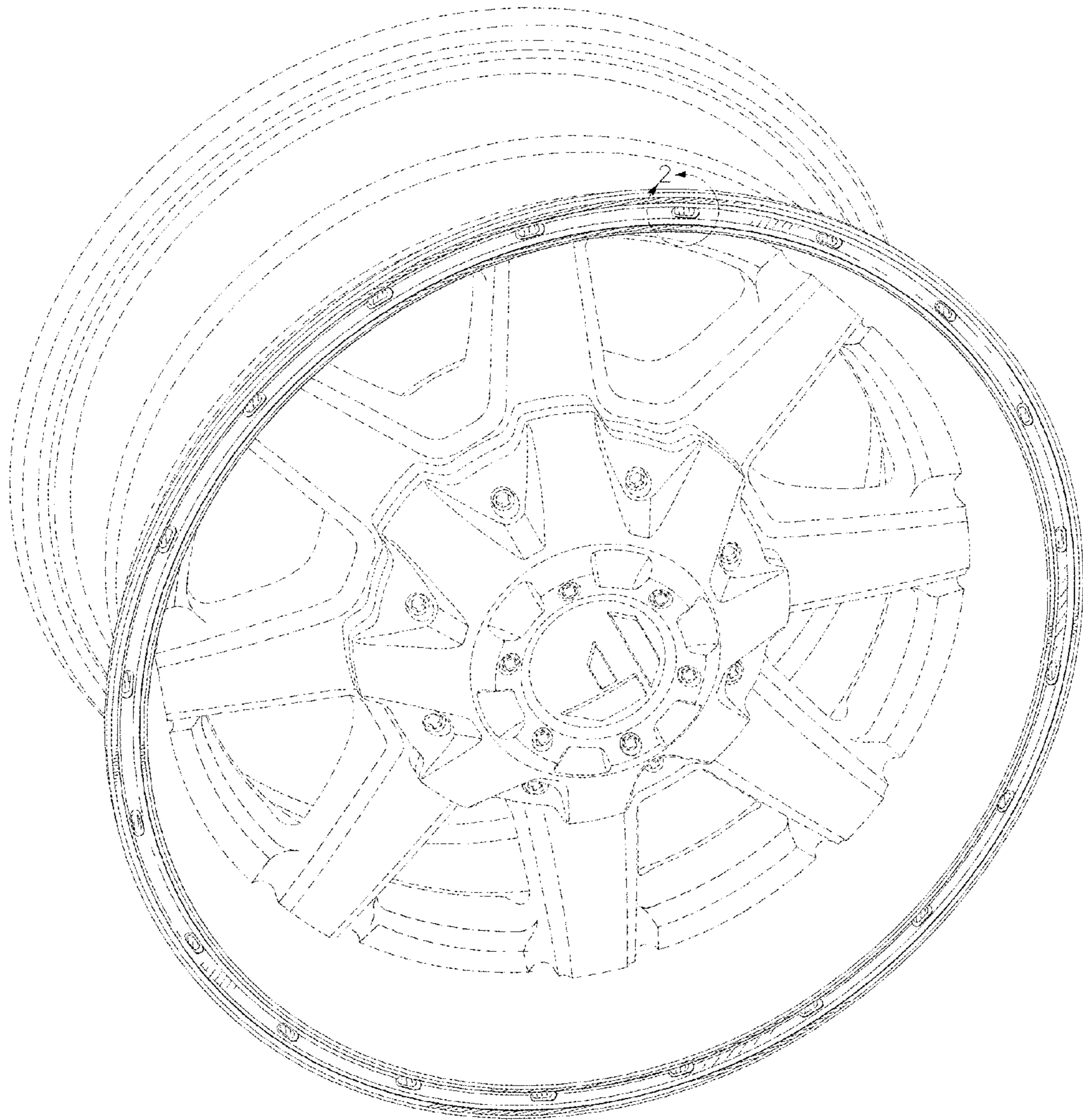

FIG. 2

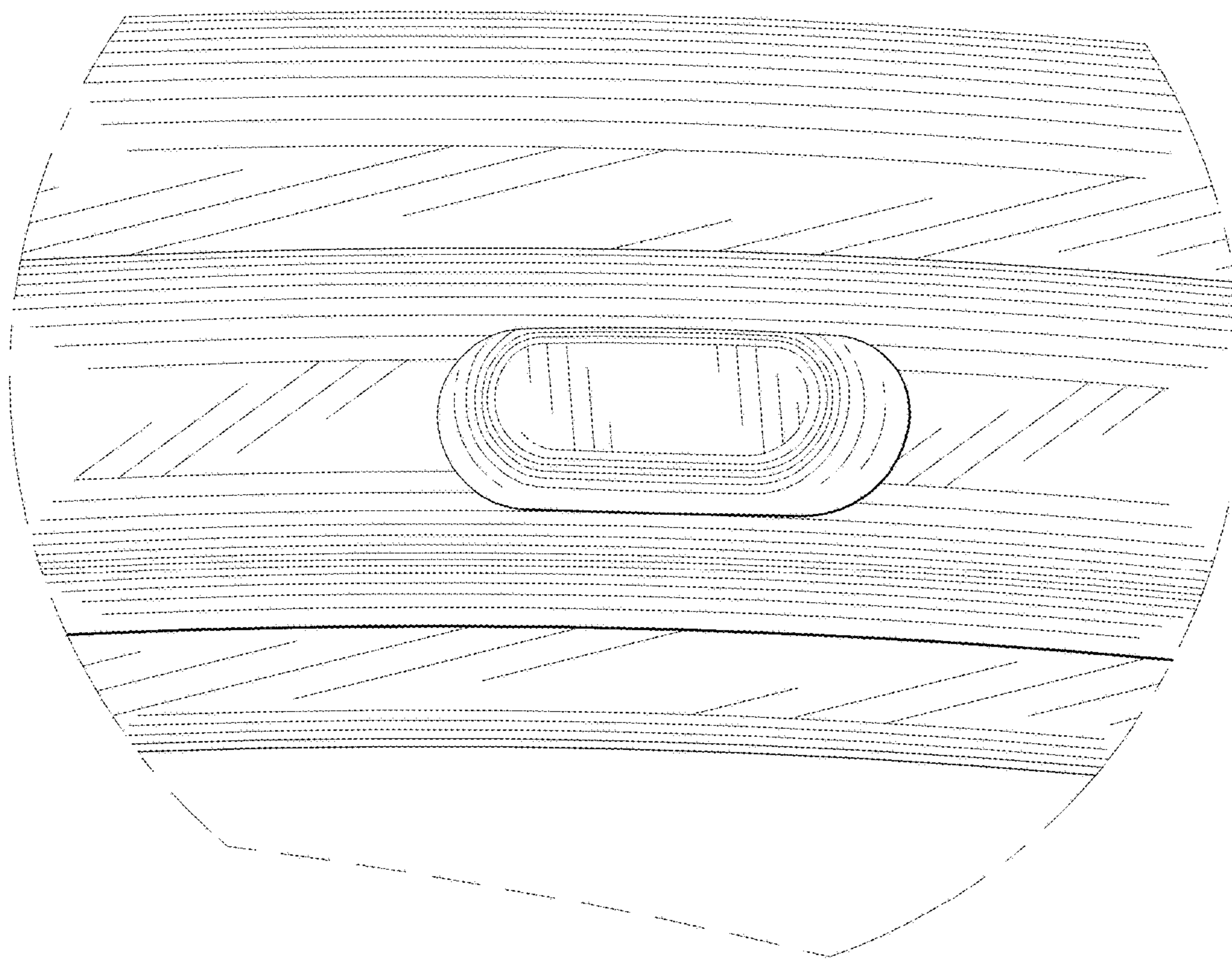

FIG. 3

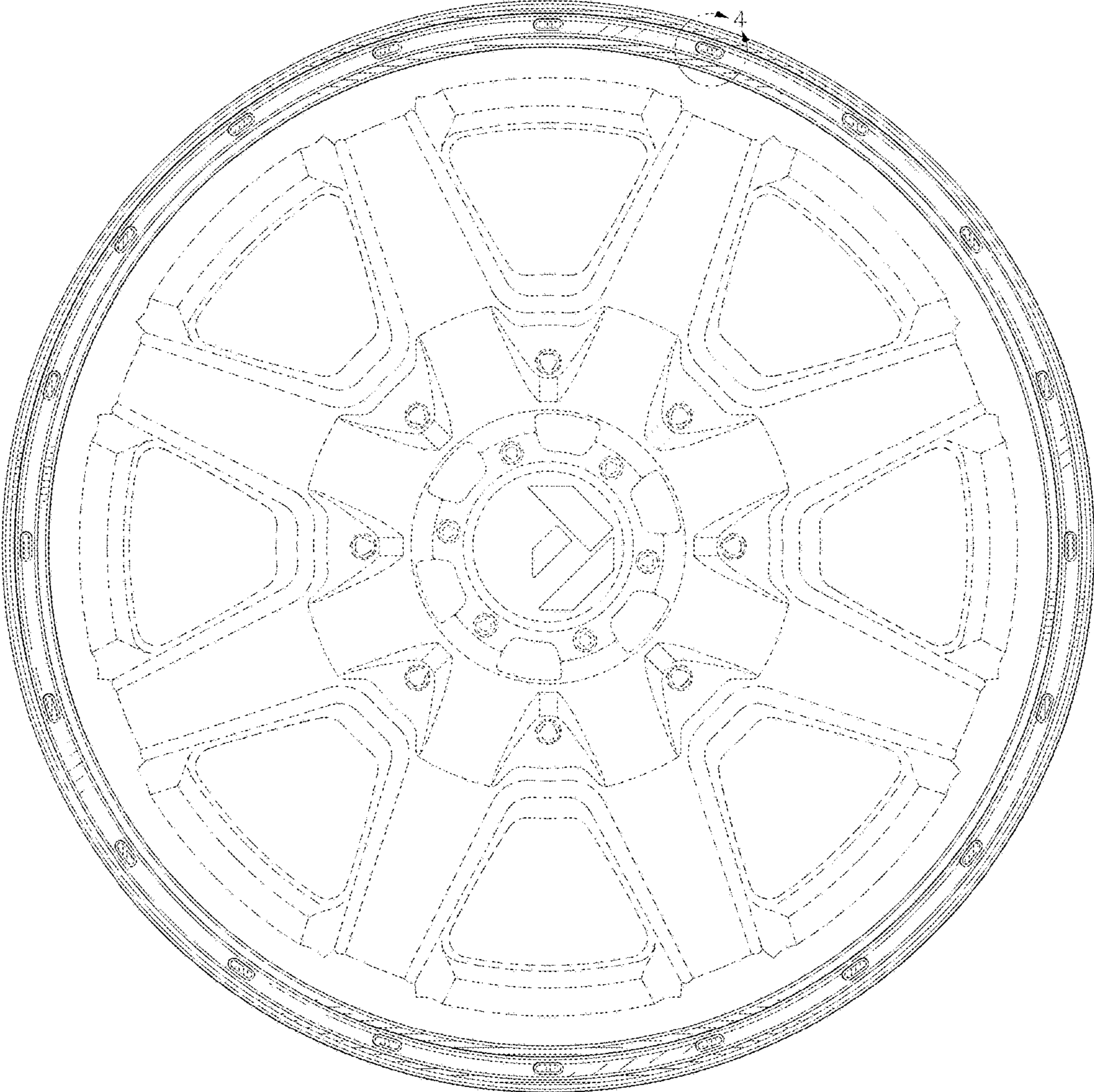
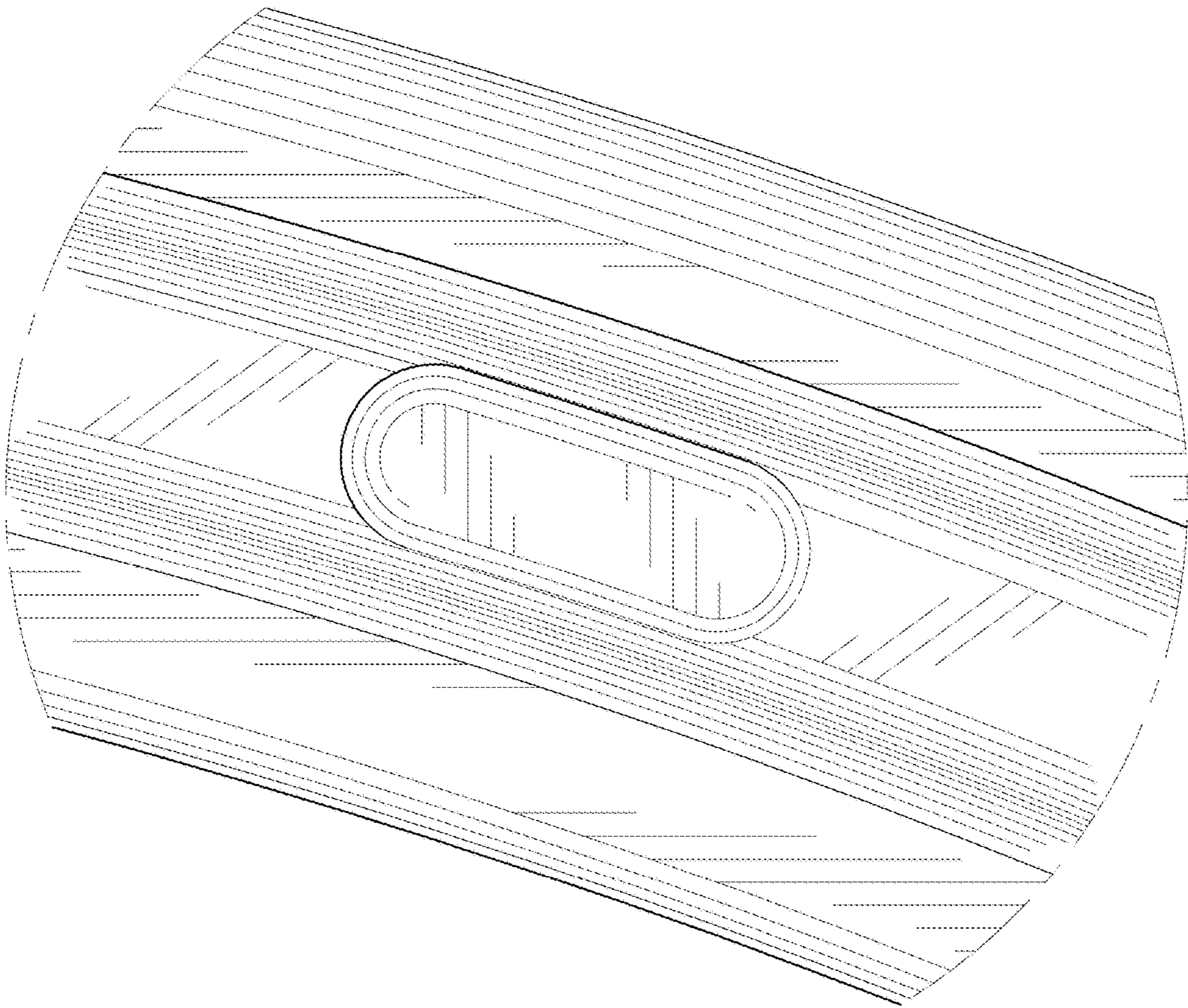

FIG. 4



*FIG. 5*

