



US00D823676S

(12) **United States Design Patent**  
**Manabe et al.**

(10) **Patent No.:** **US D823,676 S**  
(45) **Date of Patent:** **\*\* Jul. 24, 2018**

(54) **TOOL FOR FIXING A TENSION MEMBER OF COMPOSITE STRAND FOR PRESTRESSED CONCRETE REINFORCEMENT AND POST TENSIONING CONCRETE STRUCTURE**

(71) Applicant: **TOKYO ROPE MFG. CO., LTD.**,  
Chuo-ku, Tokyo (JP)

(72) Inventors: **Daisuke Manabe**, Kasumigaura (JP);  
**Shunji Hachisuka**, Kasumigaura (JP);  
**Hiroshi Kimura**, Noda (JP); **Yoshihiro Tamura**, Kashiwa (JP)

(73) Assignee: **TOKYO ROPE MFG. CO., LTD.**,  
Tokyo (JP)

(\*\*) Term: **15 Years**

(21) Appl. No.: **29/610,086**

(22) Filed: **Jul. 10, 2017**

**Related U.S. Application Data**

(62) Division of application No. 29/517,806, filed on Feb. 17, 2015, now Pat. No. Des. 809,907.

(51) **LOC (11) Cl.** ..... **08-08**

(52) **U.S. Cl.**  
USPC ..... **D8/383**; D8/382

(58) **Field of Classification Search**  
USPC ..... D8/383, 382, 385, 393, 394, 396, 499,  
D8/354, 355, 14, 44, 47, 71, 72  
(Continued)

(56) **References Cited**

**U.S. PATENT DOCUMENTS**

1,408,144 A \* 2/1922 Snow ..... F16G 11/048  
403/275  
1,600,521 A \* 9/1926 Smith ..... F16G 11/048  
403/211

(Continued)

**OTHER PUBLICATIONS**

Related U.S. Appl. No. 29/610,082; First Named Inventor: Daisuke Manabe; Title: "Tool for Fixing Tension Member of Composite Strand for Prestressed Concrete Reinforcement and Post Tensioning for Concrete Structure"; filed Jul. 10, 2017.

*Primary Examiner* — Sandra S Snapp

*Assistant Examiner* — Ieisha N Price

(74) *Attorney, Agent, or Firm* — Holtz, Holtz & Volek PC

(57) **CLAIM**

The ornamental design for a tool for fixing a tension member of composite strand for prestressed concrete reinforcement and post tensioning for concrete structure, as shown and described.

**DESCRIPTION**

FIG. 1 is a front, top and left side perspective view of a first embodiment of a tool for fixing a tension member of composite strand for prestressed concrete reinforcement and post tensioning concrete structure, showing our new design; FIG. 2 is a front view thereof, the rear being identical; FIG. 3 is a left side view thereof; FIG. 4 is a right side view thereof; FIG. 5 is a top plan view thereof, the bottom plan being identical; FIG. 6 is a front view thereof, wherein three-fourths of the article has been removed for ease of illustration; FIG. 7 is a rear view of FIG. 6; FIG. 8 is a left side view of FIG. 6; FIG. 9 is a right side view of FIG. 6; FIG. 10 is a top plan view of FIG. 6; FIG. 11 is a bottom plan view of FIG. 6; FIG. 12 is a perspective view showing the environmental use thereof; and FIG. 13 is an exploded perspective view showing the environmental use thereof.  
FIG. 14 is a front, top and left side perspective view of a second embodiment of a tool for fixing a tension member of composite strand for prestressed concrete reinforcement and post tensioning concrete structure, showing our new design;

(Continued)

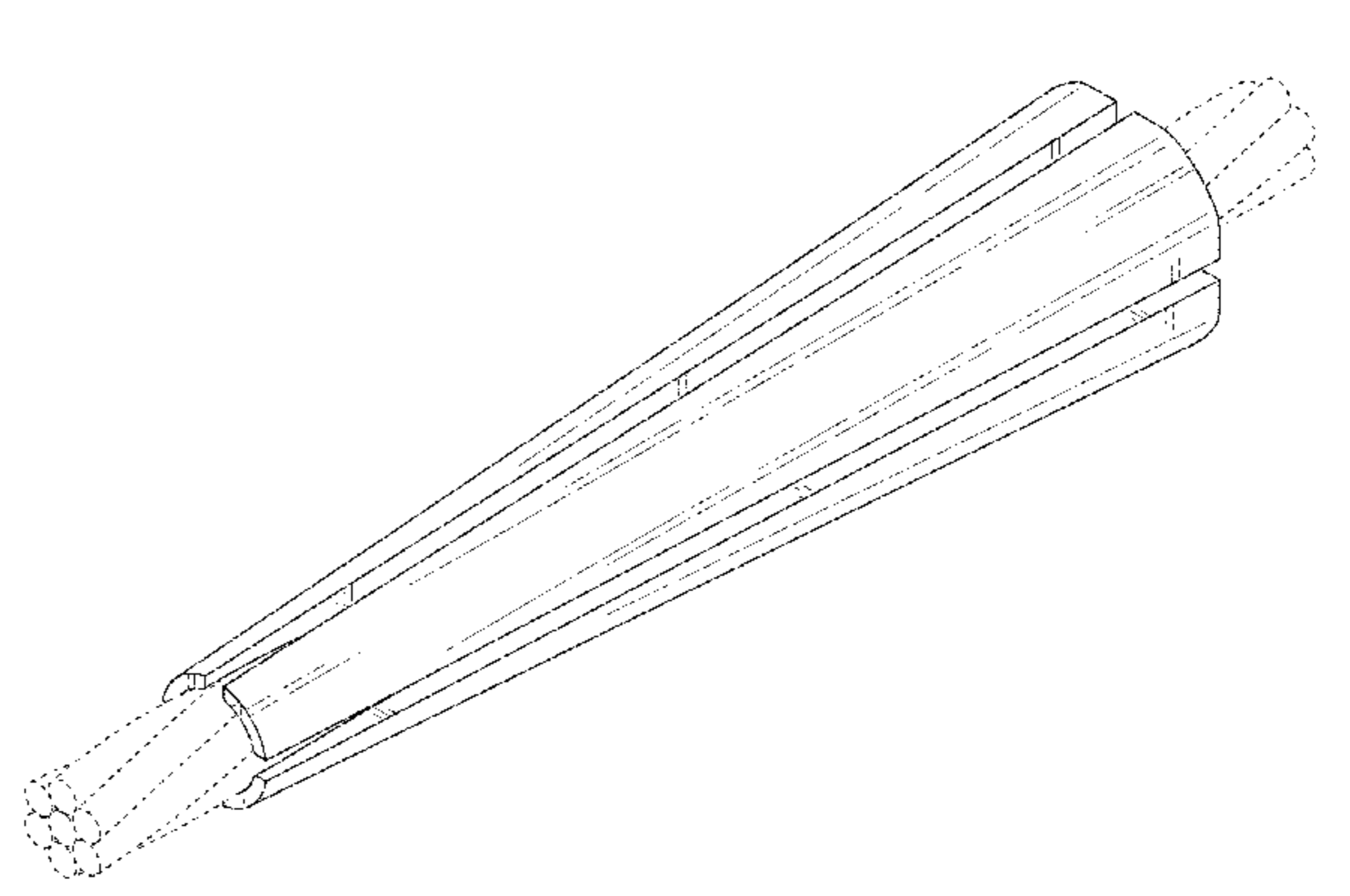
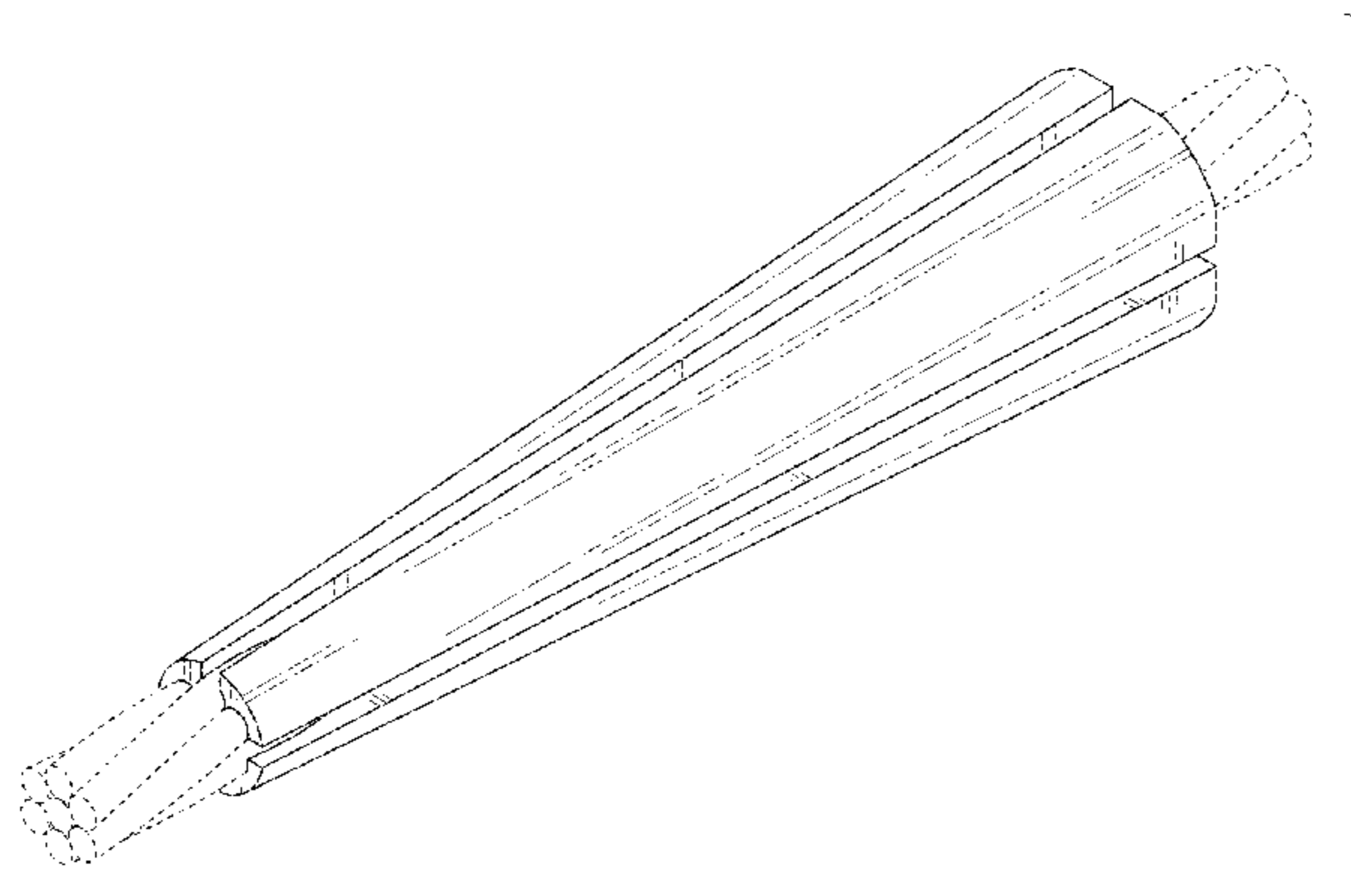

FIG. 15 is a front view thereof, the rear being identical;  
 FIG. 16 is a left side view thereof;  
 FIG. 17 is a right side view thereof;  
 FIG. 18 is a top plan view thereof, the bottom plan being identical;  
 FIG. 19 is a front view thereof, wherein three-fourths of the article has been removed for ease of illustration;  
 FIG. 20 is a rear view of FIG. 19;  
 FIG. 21 is a left side view of FIG. 19;  
 FIG. 22 is a right side view of FIG. 19;  
 FIG. 23 is a top plan view of FIG. 19;  
 FIG. 24 is a bottom plan view of FIG. 19;  
 FIG. 25 is an enlarged cross sectional view taken along line 25-25 in FIG. 15  
 FIG. 26 is a perspective view showing the environmental use thereof; and,  
 FIG. 27 is an exploded perspective view showing the environmental use thereof.  
 The broken line showing of tension members shown in FIGS. 12, 13, 26 and 27 illustrates the environment of the claimed design and forms no part thereof. The broken lines shown in FIG. 25 illustrate portions of the tool for fixing a tension member of composite strand for prestressed concrete reinforcement and post tensioning concrete structure and form no part of the claimed design.

**1 Claim, 13 Drawing Sheets**

(58) **Field of Classification Search**

CPC . D07B 1/18; D07B 1/005; D07B 9/00; D07B 2201/2083; D07B 2201/2084; D07B 2201/2085; D07B 2201/2089; F16G 11/00; F16G 11/03; F16G 11/04; F16G 11/048; F16G 11/08; F16G 11/10; F16G 11/105; F16G 11/108

See application file for complete search history.

(56)

**References Cited**

U.S. PATENT DOCUMENTS

1,797,194 A	3/1931	Knapp et al.	
1,857,436 A	5/1932	Cole et al.	
1,894,389 A	1/1933	Zapf et al.	
2,075,335 A	3/1937	Brown et al.	
2,180,866 A	11/1939	Cryer et al.	
2,294,398 A *	9/1942	Ferguson .....	F16G 11/048 29/452
2,341,922 A	2/1944	King et al.	
3,254,383 A	6/1966	Ehmann et al.	
3,374,511 A	3/1968	Barker et al.	
3,475,795 A	11/1969	Youngblood et al.	
3,600,014 A	8/1971	Harris et al.	
3,676,899 A	7/1972	Ehlert et al.	
3,879,147 A	4/1975	Morell et al.	
3,952,377 A	4/1976	Morell et al.	
4,066,368 A	1/1978	Mastalski et al.	
4,509,233 A	4/1985	Shaw et al.	
4,633,540 A *	1/1987	Jungwirth .....	E04C 5/122 14/21
5,211,500 A	5/1993	Takaki et al.	
5,233,730 A	8/1993	Milne et al.	
5,369,849 A	12/1994	Defrance et al.	
5,802,788 A *	9/1998	Ozawa .....	E04C 5/122 24/122.6
6,015,953 A	1/2000	Tosaka et al.	
7,055,288 B2 *	6/2006	Coogan .....	E04C 5/10 52/222
7,716,800 B1 *	5/2010	Percheron .....	E04C 5/122 24/122.3
D775,085 S	12/2016	Hachisuka et al.	
D809,907 S *	2/2018	Manabe .....	D8/383
9,909,315 B2 *	3/2018	Sorkin .....	E04C 5/122
9,923,355 B2 *	3/2018	Larsson .....	H02G 15/06
D814,279 S *	4/2018	Manabe .....	D8/383
2002/0076274 A1	6/2002	Carlsen et al.	
2012/0141198 A1	6/2012	Kondo et al.	
2012/0240365 A1	9/2012	Van Der Ende	
2016/0237615 A1	8/2016	Manabe et al.	
2017/0343078 A1 *	11/2017	Manabe .....	F16G 11/048

\* cited by examiner

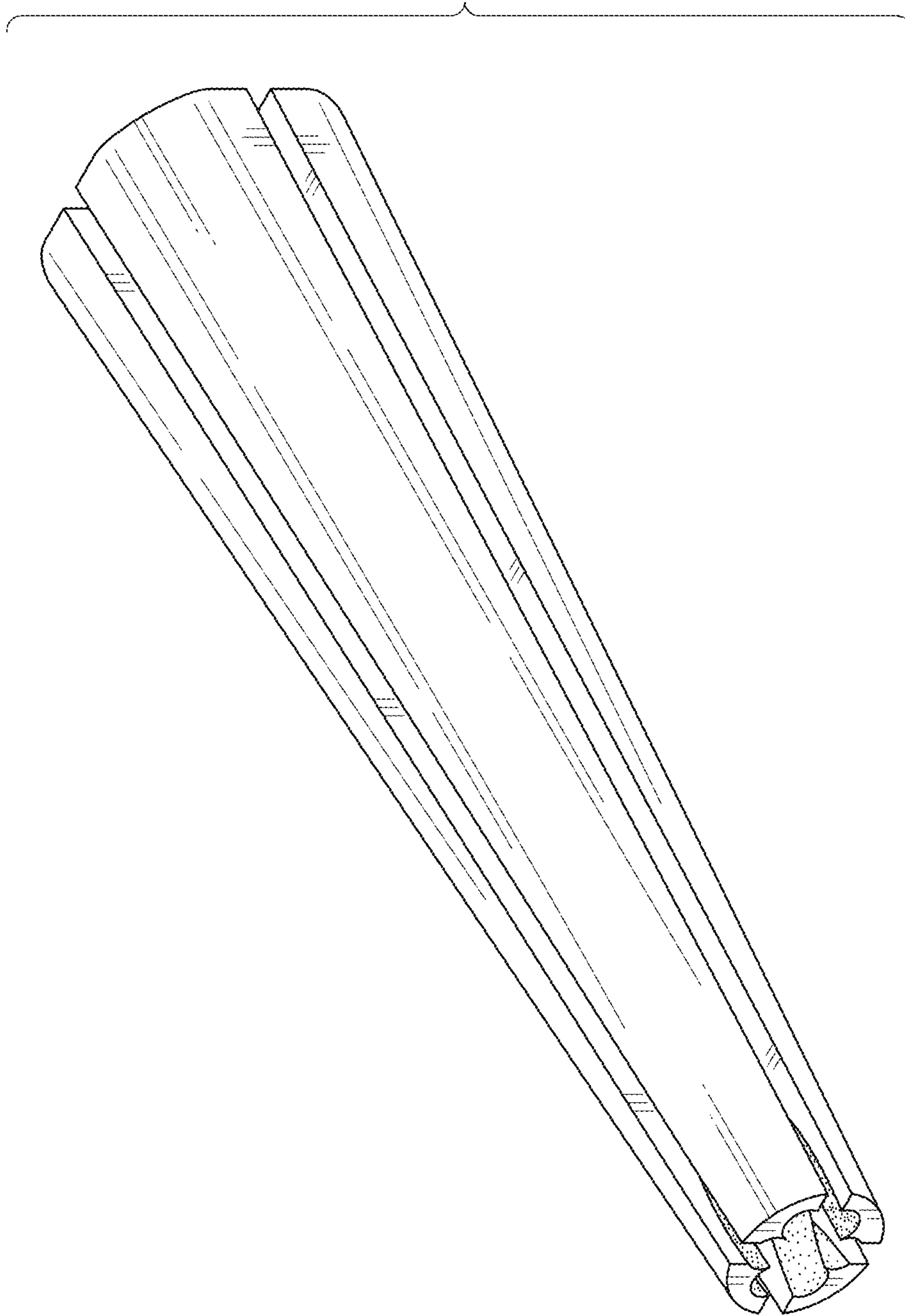

Fig. 1

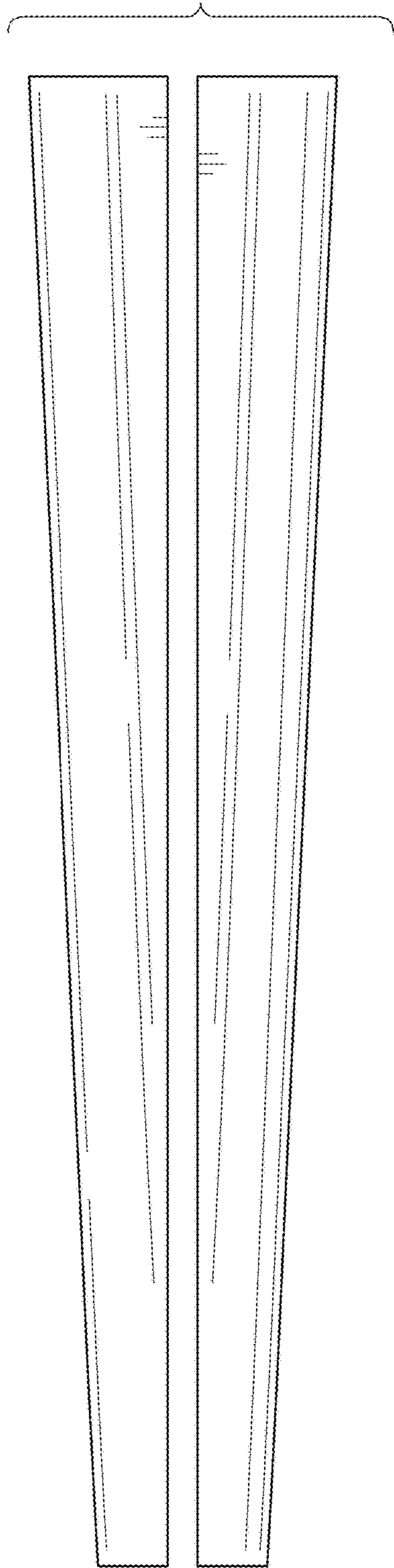

Fig. 2

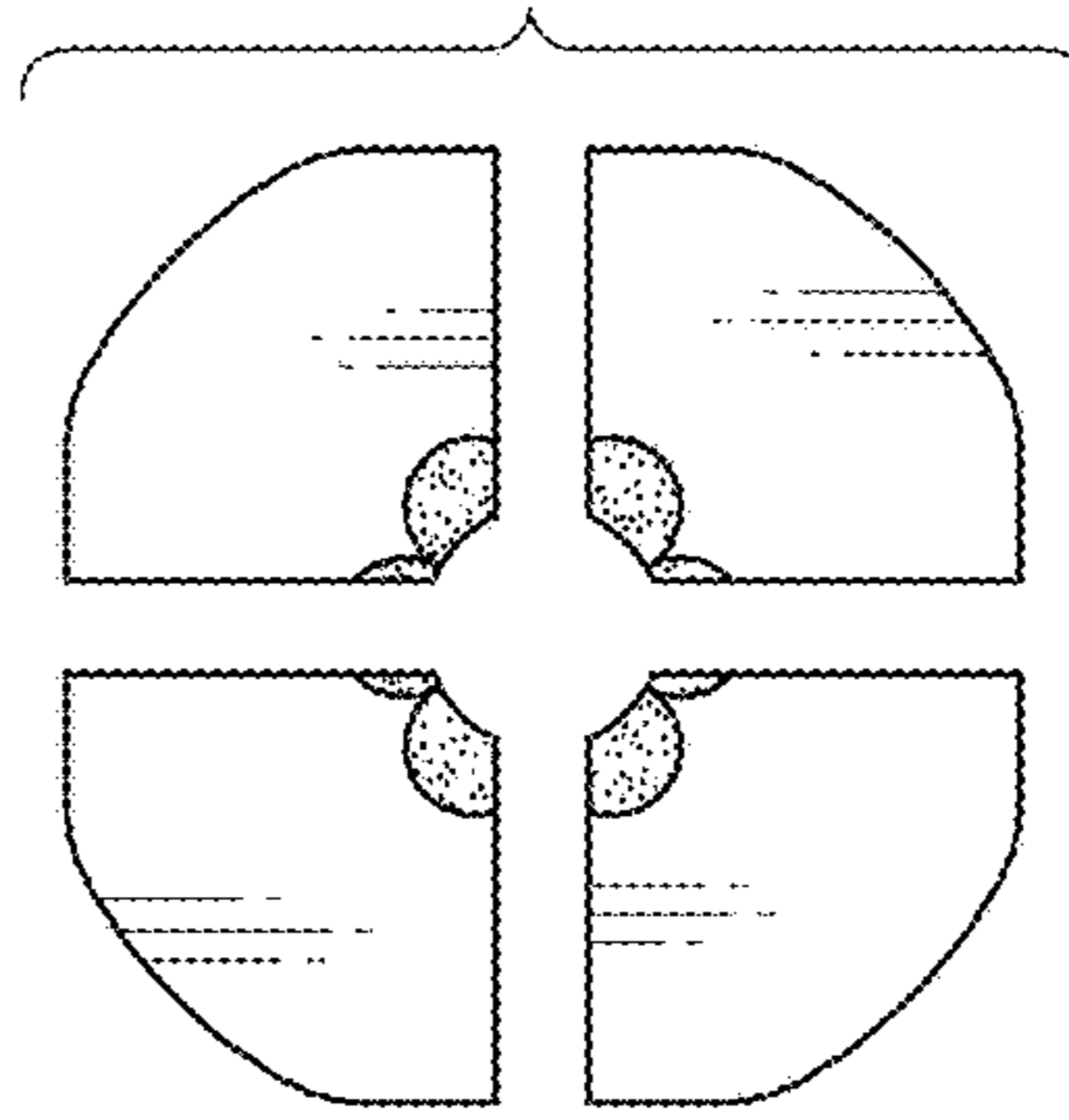

Fig. 4

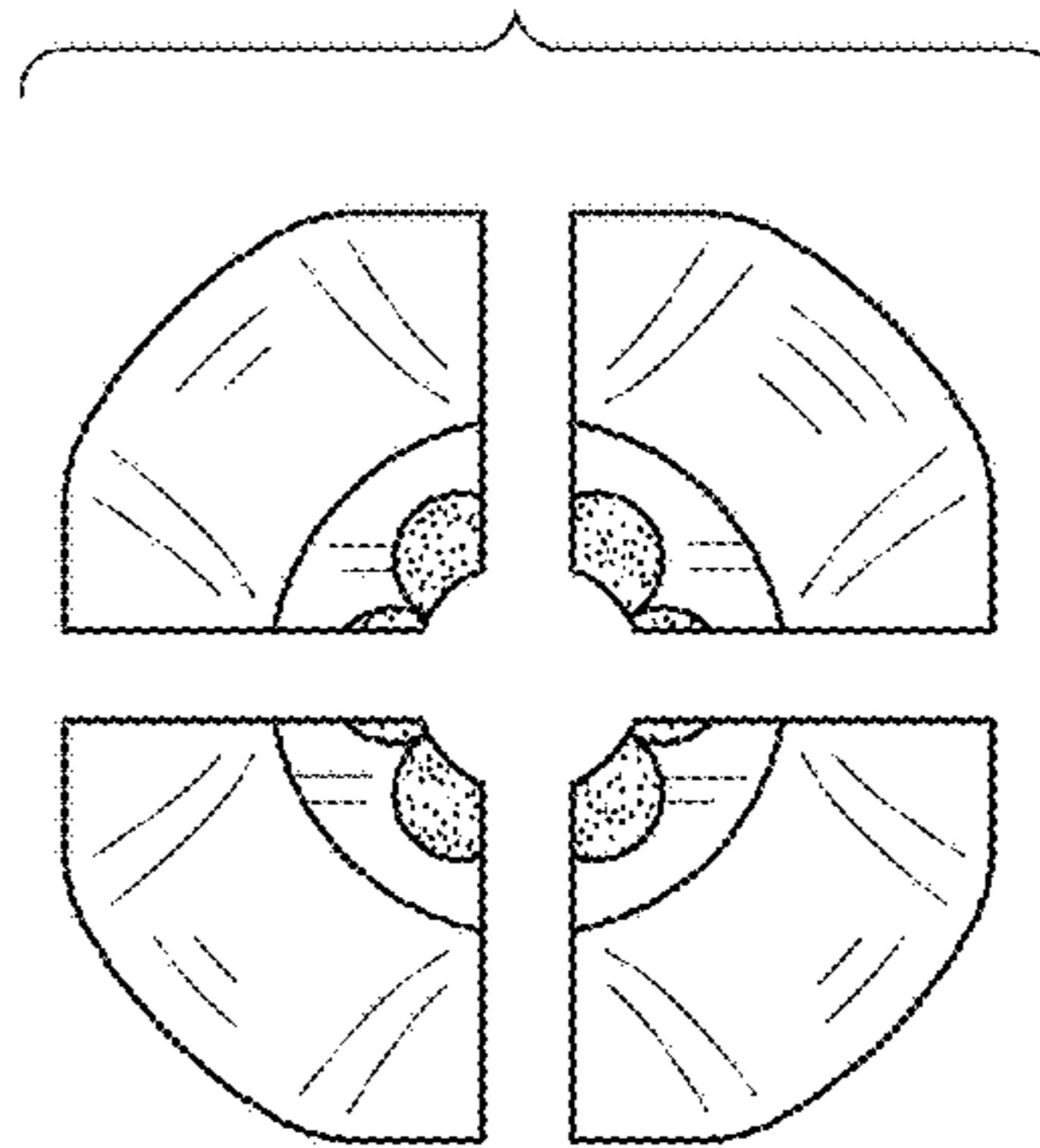

Fig. 3

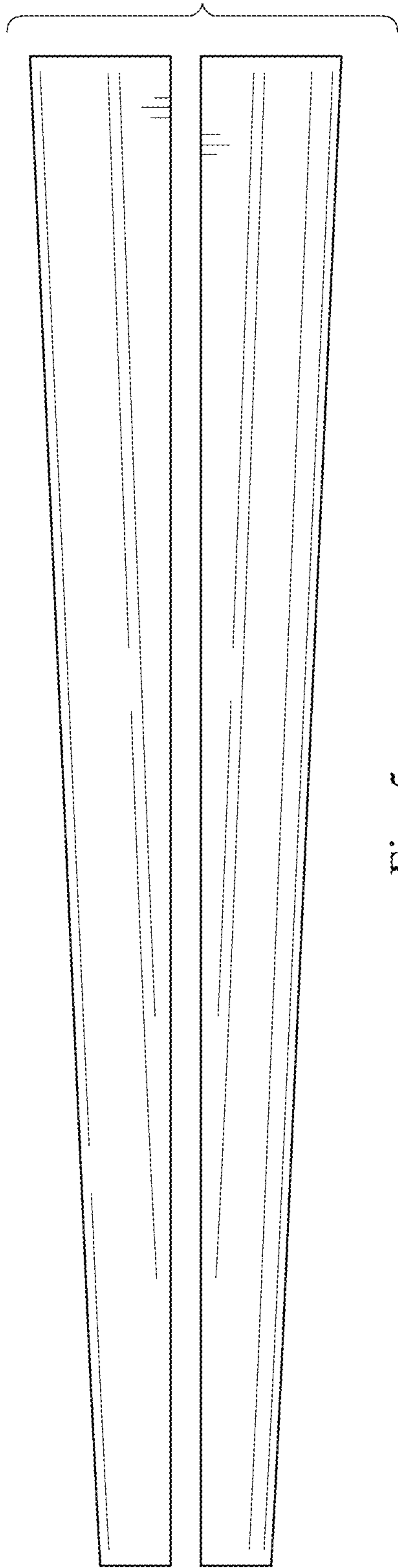

Fig. 5

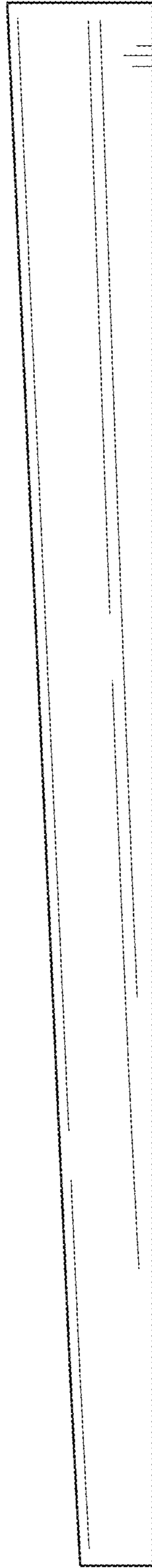

Fig. 6

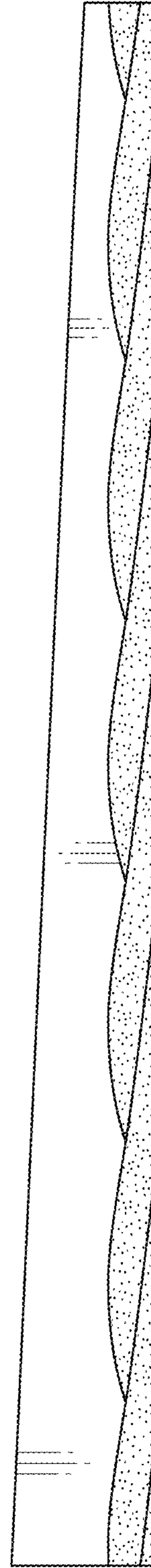

Fig. 7

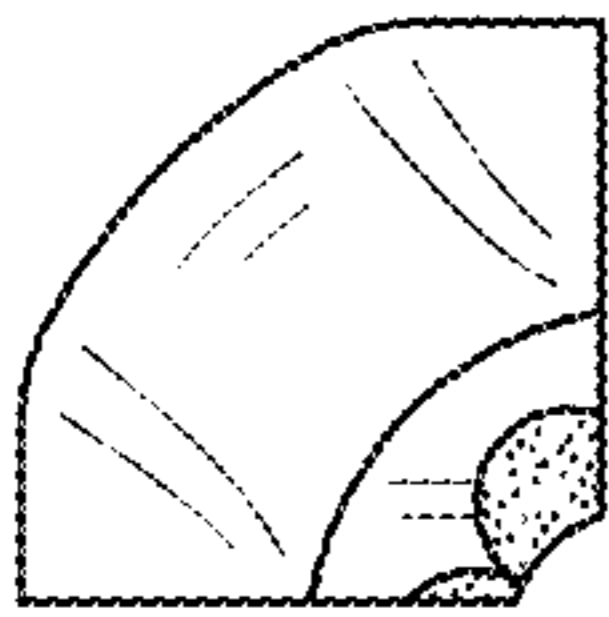

Fig. 8

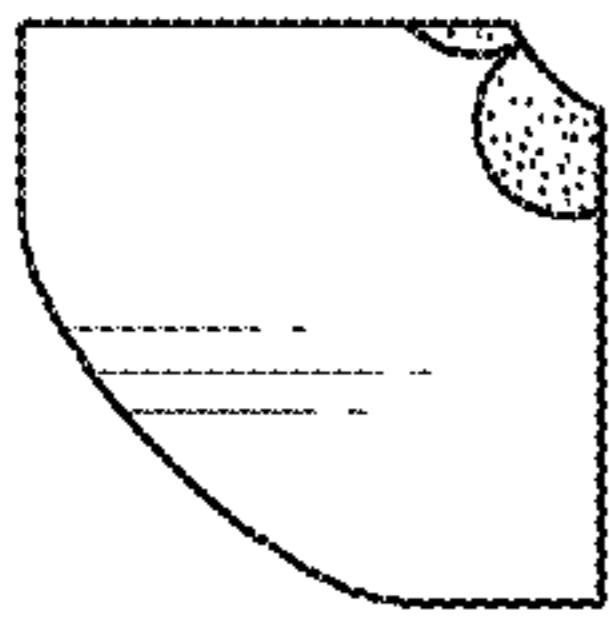

Fig. 9

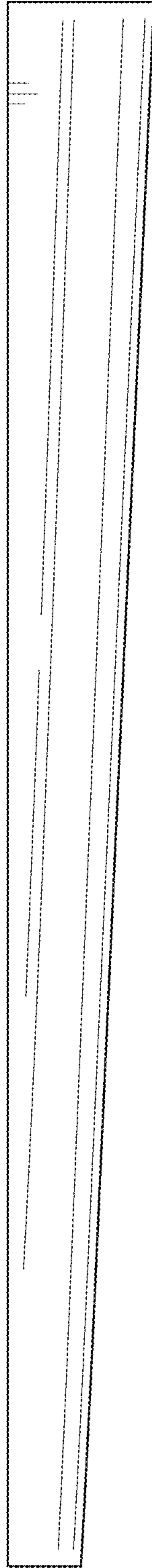

Fig. 10

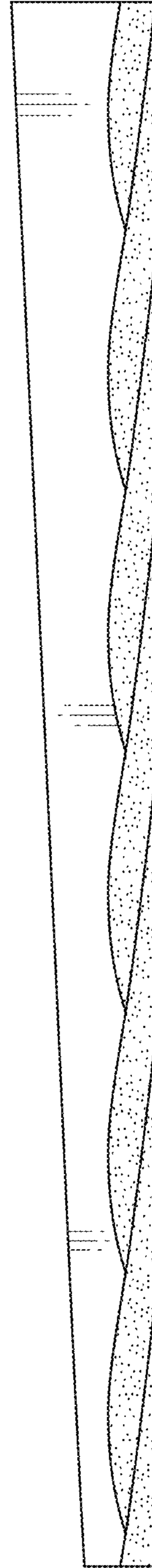

Fig. 11

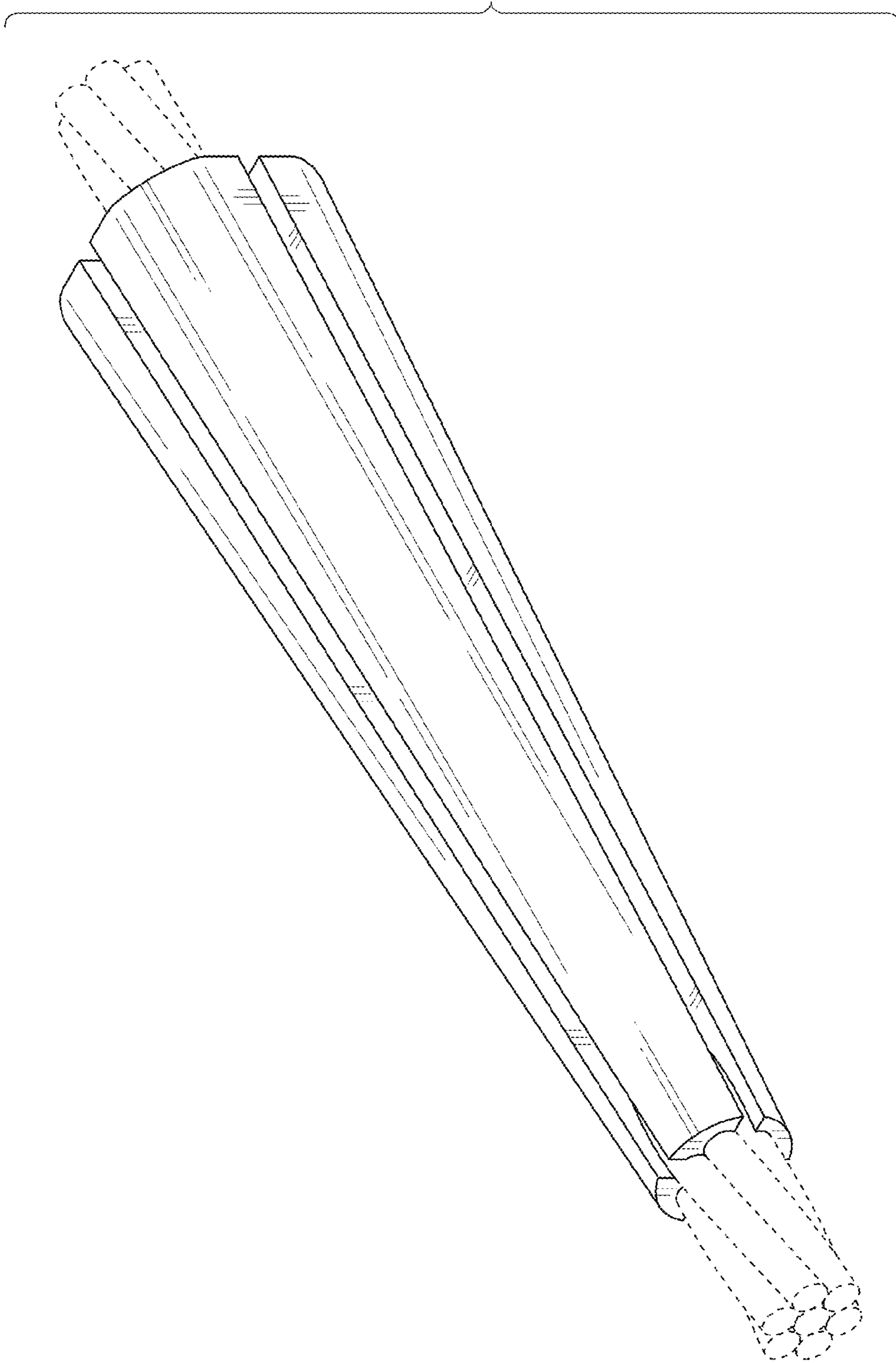

Fig. 12

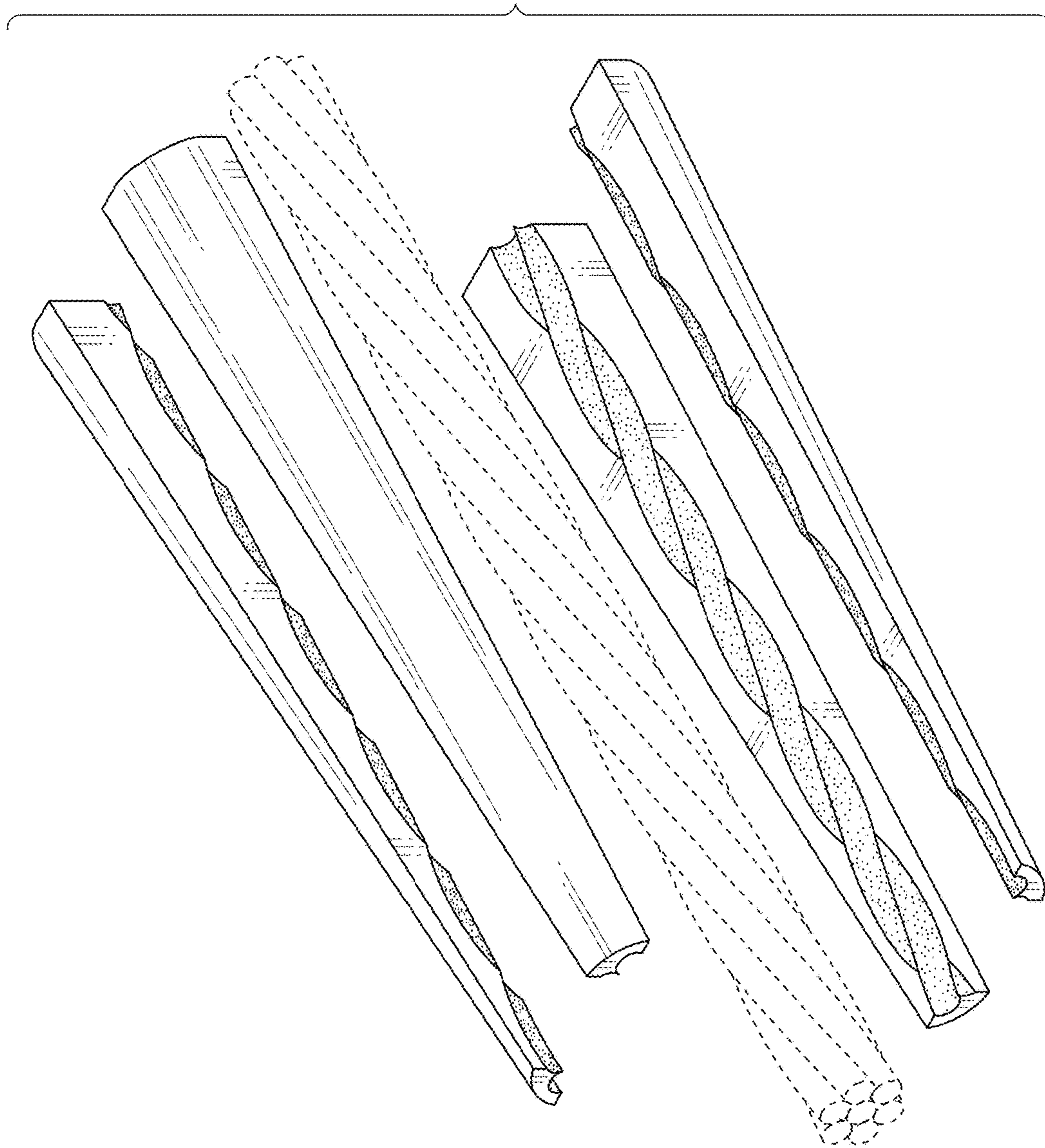

Fig. 13



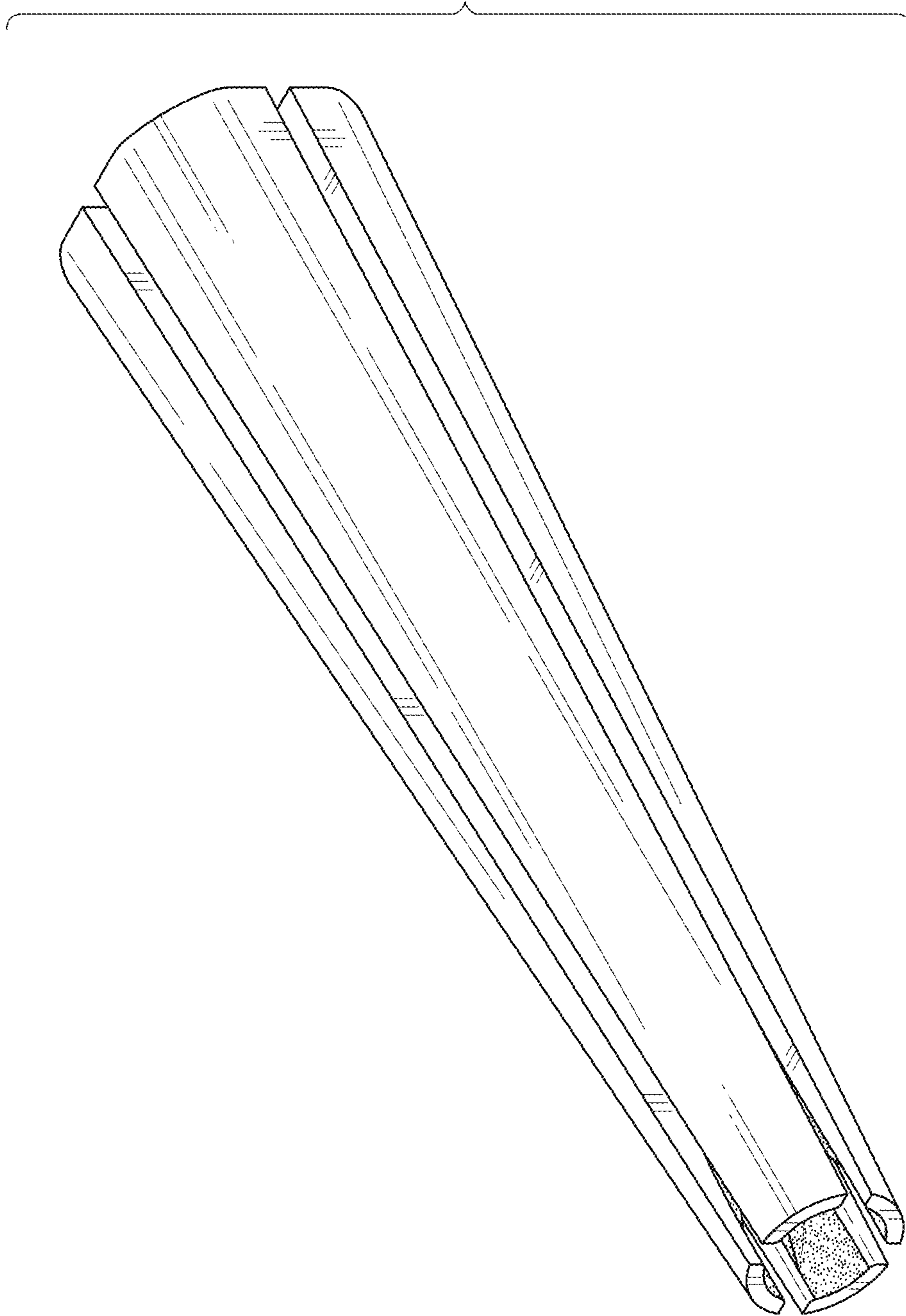

Fig. 14

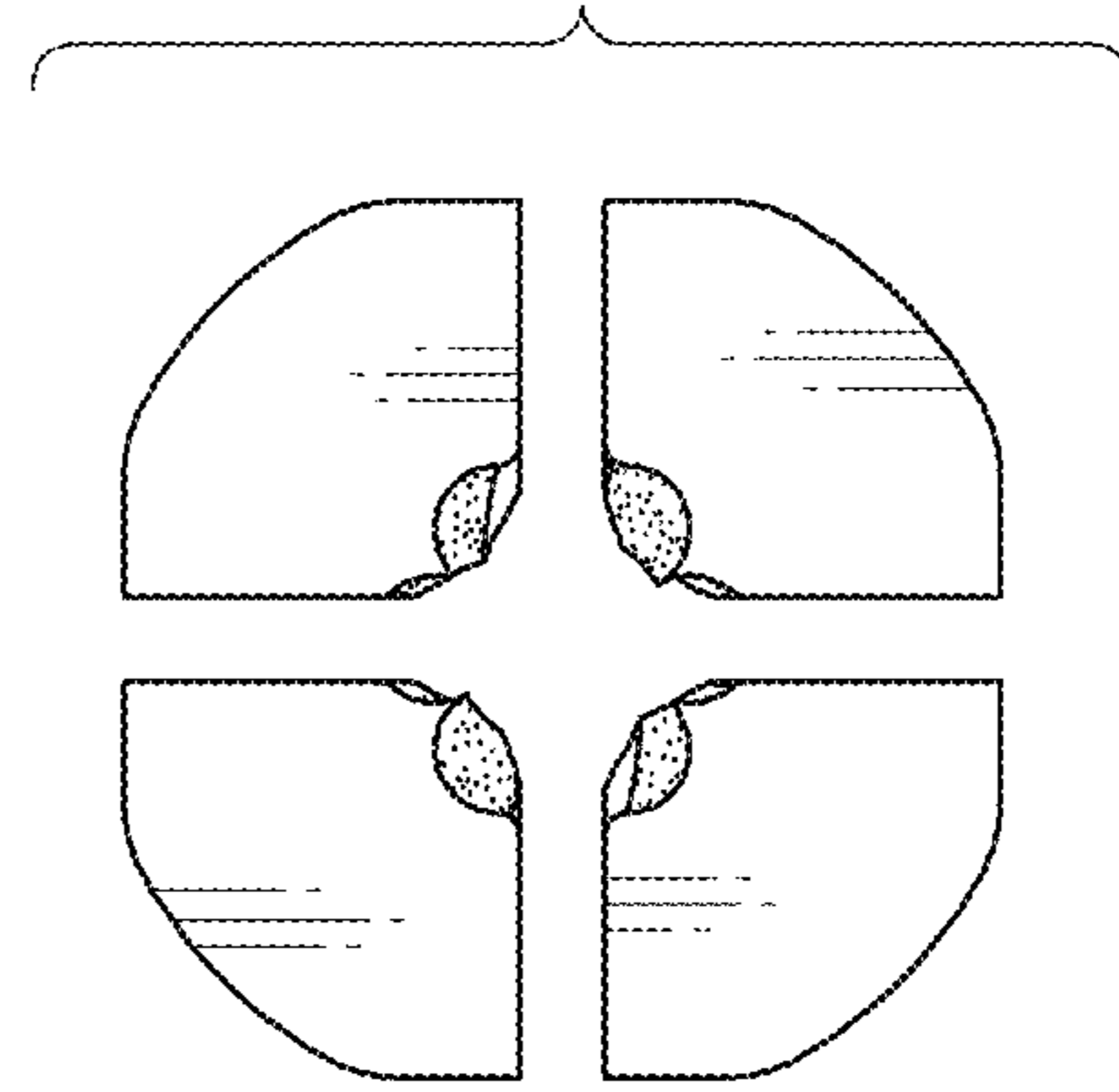
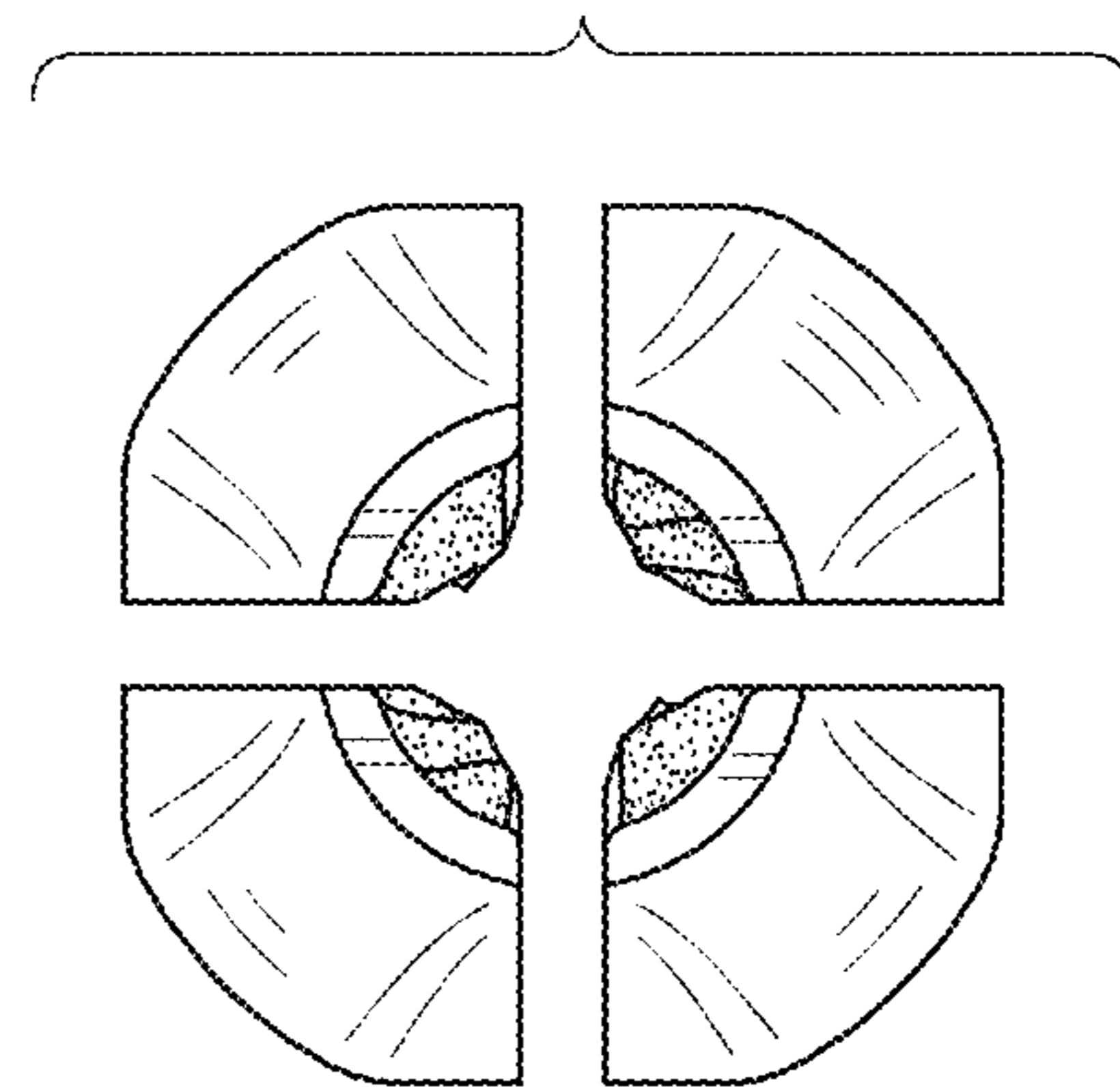
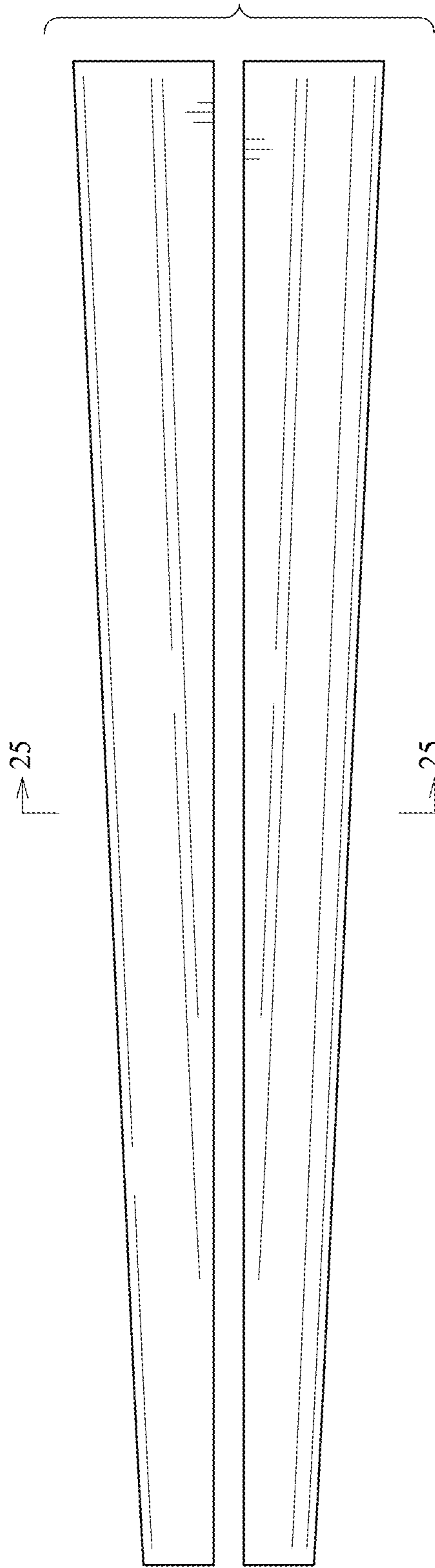
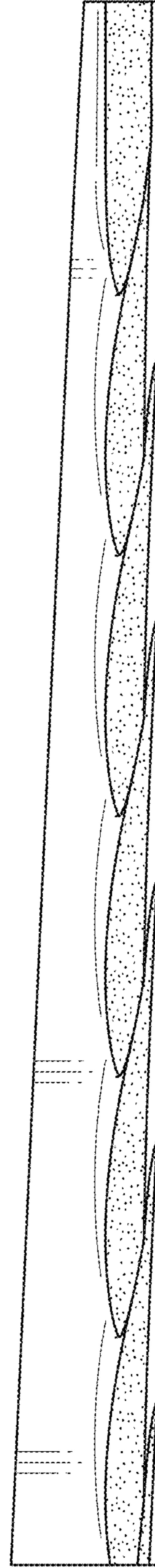
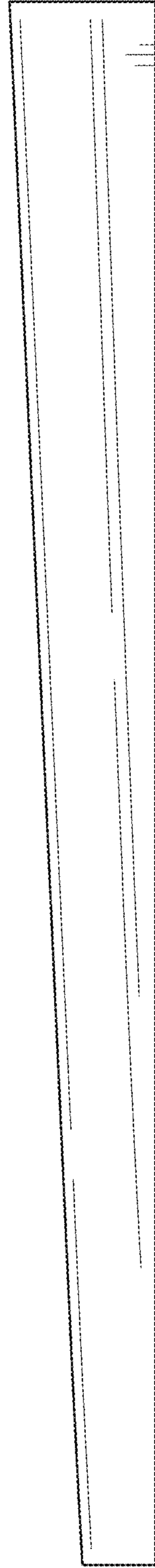
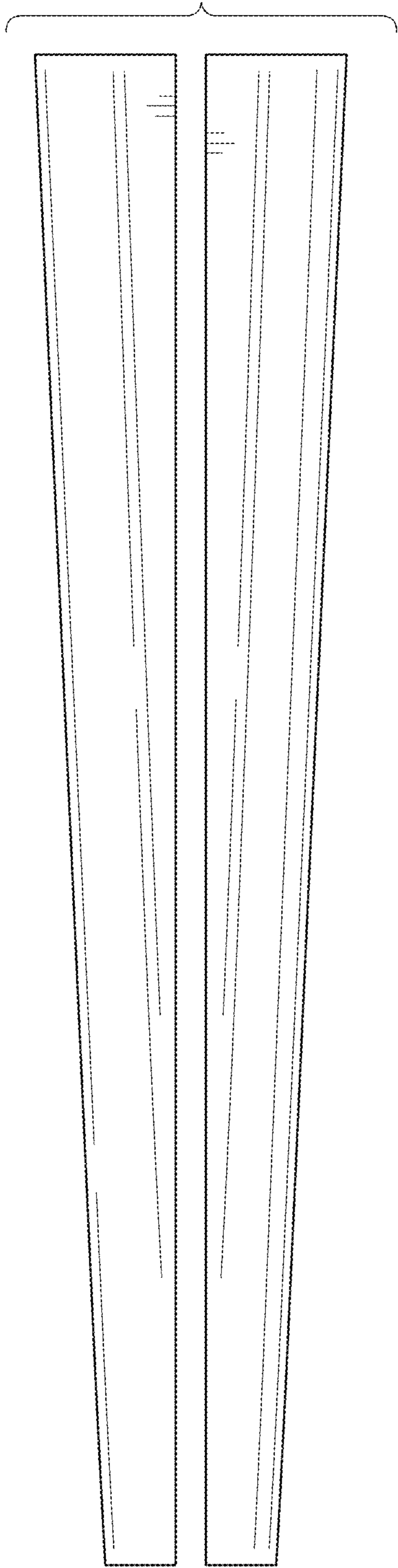

Fig. 15

Fig. 16

Fig. 17



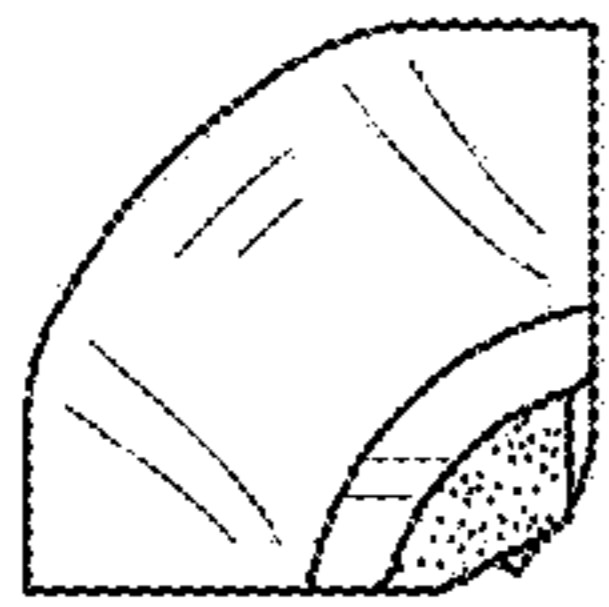

Fig. 21

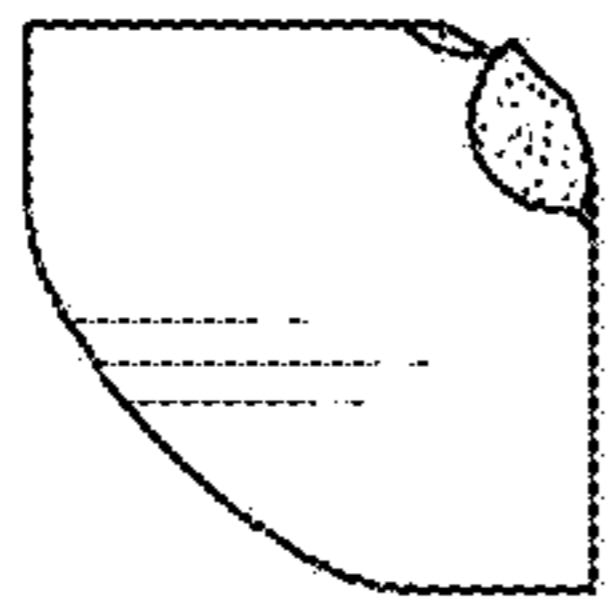

Fig. 22

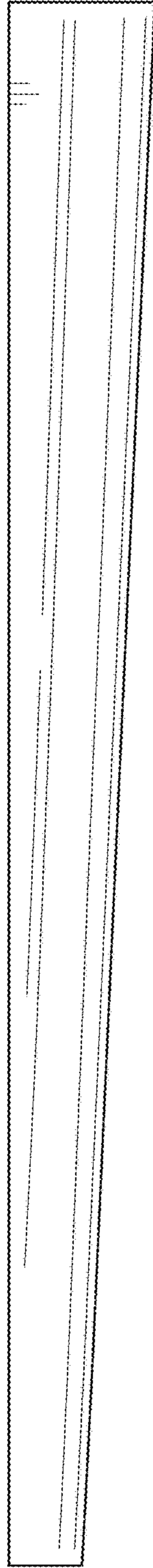

Fig. 23

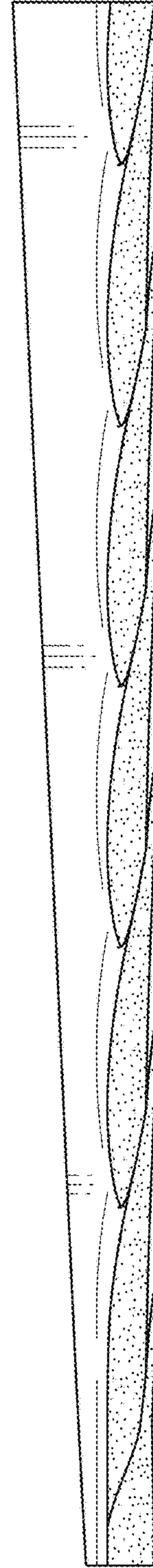

Fig. 24

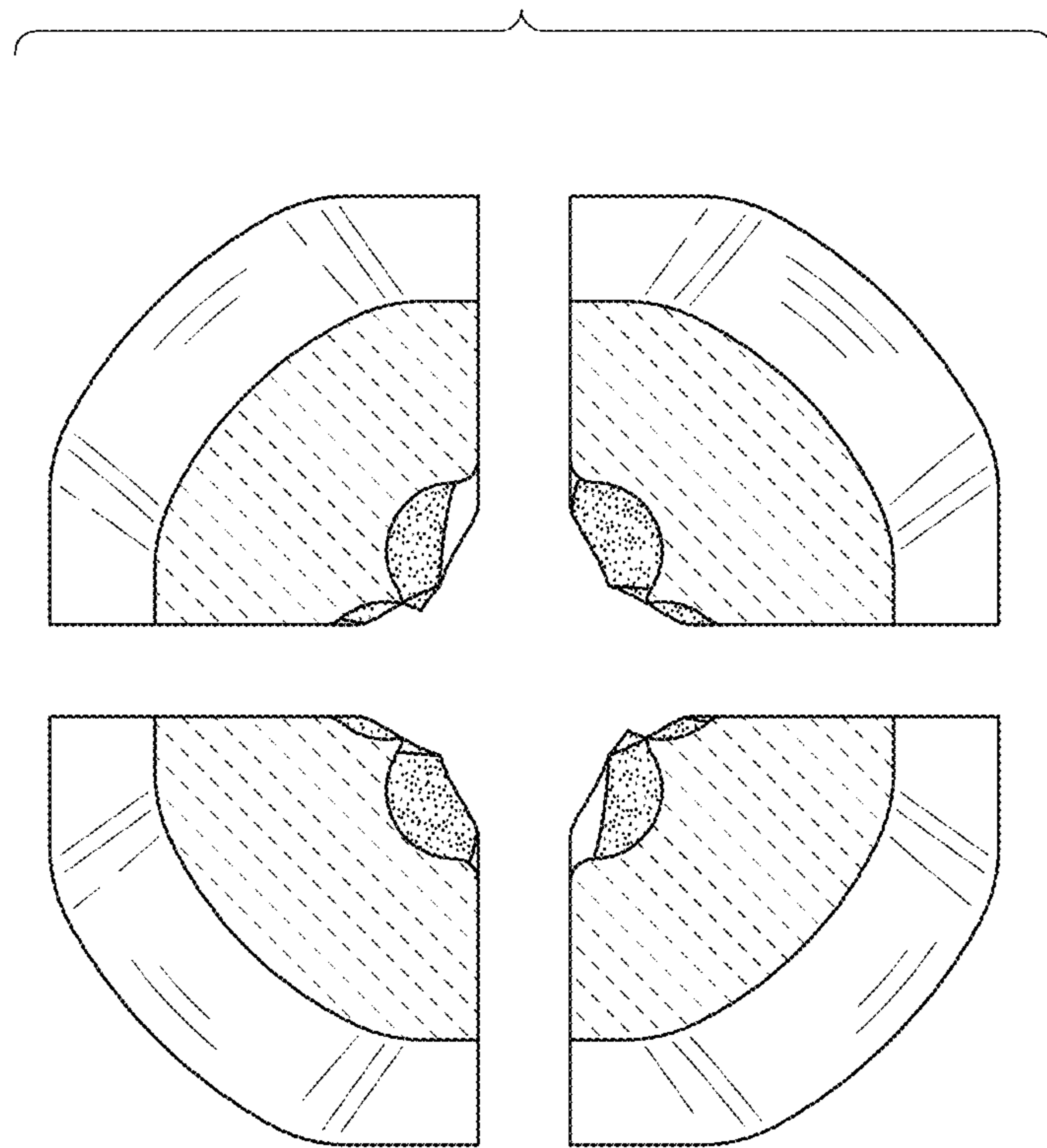

Fig. 25

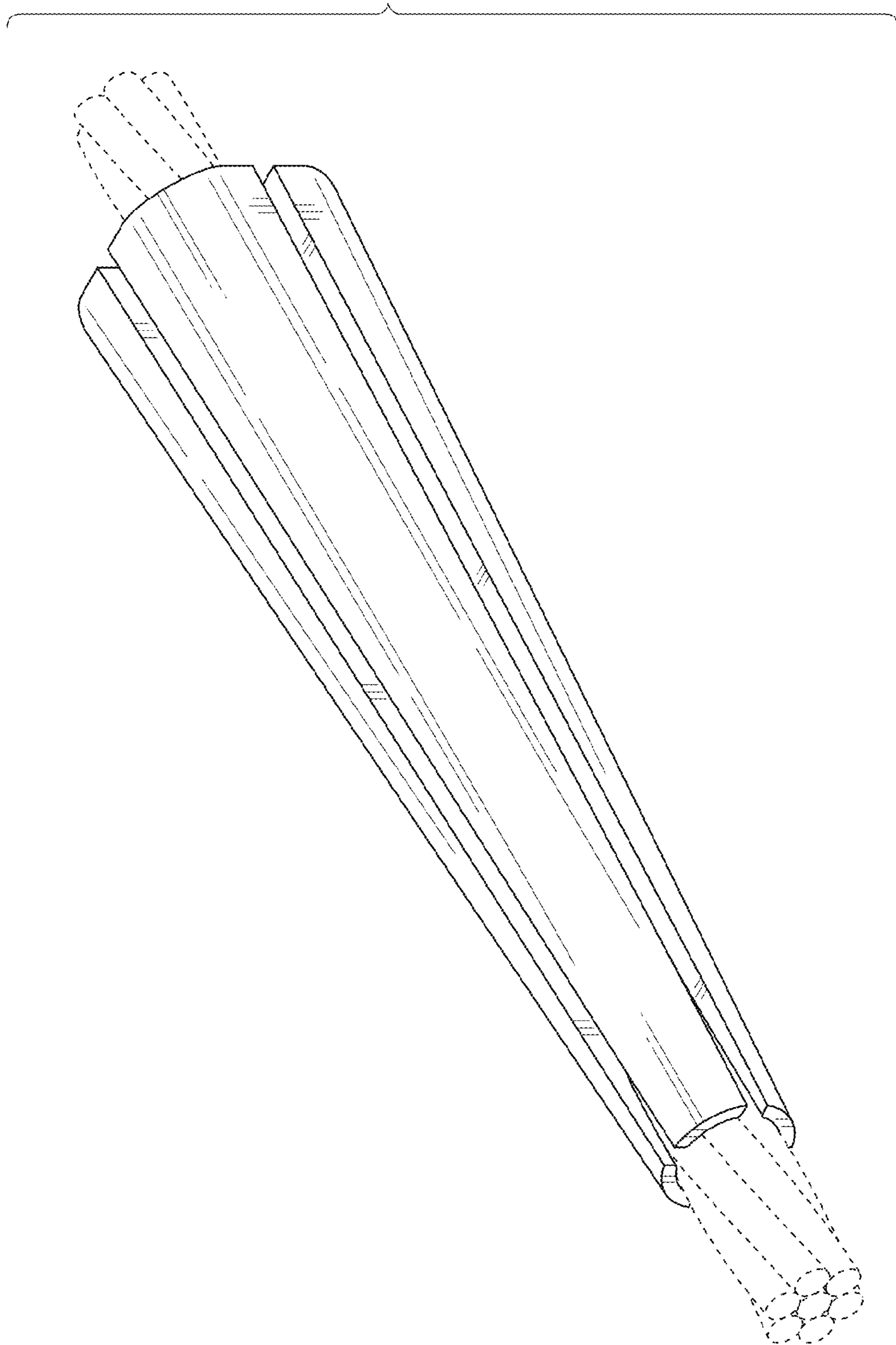

Fig. 26

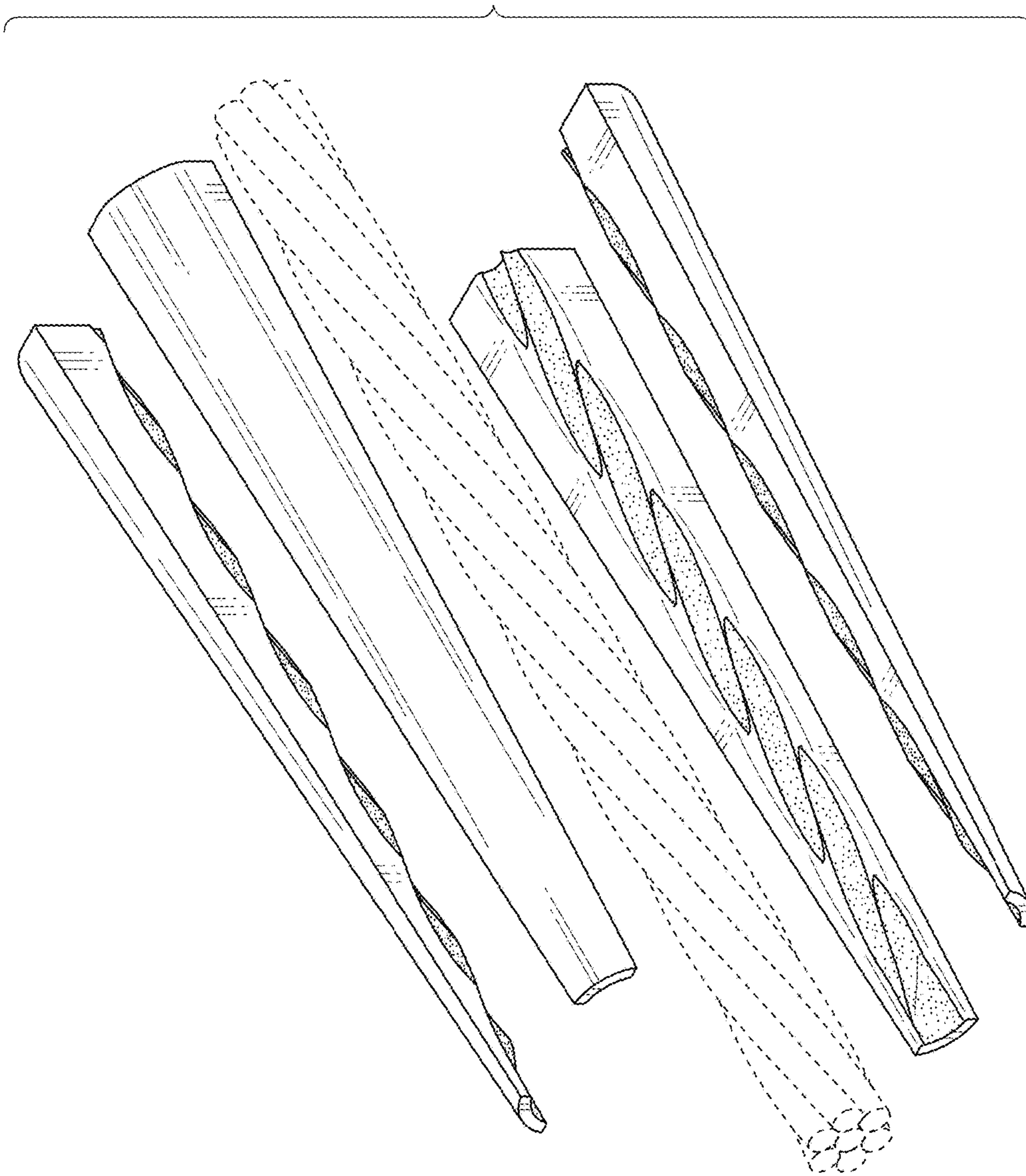

Fig. 27