



US00D823364S

(12) **United States Design Patent**
Yoshida

(10) **Patent No.:** **US D823,364 S**
(45) **Date of Patent:** **** Jul. 17, 2018**

(54) **TIRE REPAIR KIT**
(71) Applicant: **BRIDGESTONE CORPORATION**,
Tokyo (JP)
(72) Inventor: **Masaki Yoshida**, Tokyo (JP)
(73) Assignee: **BRIDGESTONE CORPORATION**,
Tokyo (JP)
(**) Term: **15 Years**
(21) Appl. No.: **29/599,134**
(22) Filed: **Mar. 31, 2017**

D638,868 S * 5/2011 Kojima D15/199
2004/0159365 A1 * 8/2004 Cowan B29C 73/166
141/38
2005/0265873 A1 * 12/2005 Chou B29C 73/166
417/552
2010/0005930 A1 * 1/2010 Lolli B29C 73/166
81/15.5

(Continued)

Primary Examiner — Patricia A Palasik
(74) *Attorney, Agent, or Firm* — Sughrue Mion, PLLC

(57) **CLAIM**

The ornamental design for a tire repair kit, as shown and described.

DESCRIPTION

(30) **Foreign Application Priority Data**
Oct. 3, 2016 (JP) 2016-021500
(51) **LOC (11) Cl.** **15-99**
(52) **U.S. Cl.**
USPC **D15/199**
(58) **Field of Classification Search**
USPC D8/105, 499; D15/199
CPC B29C 73/166; B29L 2030/00; B60S 5/046;
B65D 47/36; B66F 3/247; Y10T 29/4973;
Y10T 29/4977; Y10T 137/87169; Y10T
152/10729
See application file for complete search history.

FIG. 1 is a front perspective view of a tire repair kit showing my new design;
FIG. 2 is a rear perspective view thereof;
FIG. 3 is a front view thereof;
FIG. 4 is a top side view thereof;
FIG. 5 is a right side view thereof;
FIG. 6 is a left side view thereof;
FIG. 7 is a rear view thereof;
FIG. 8 is a bottom side view thereof;
FIG. 9 is a sectional view taken along line 9-9 in FIG. 3 with the internal parts being omitted;
FIG. 10 is a front perspective view thereof, showing the hose in an extended position
FIG. 11 is a rear perspective view thereof, showing the hose in an extended position; and,
FIG. 12 is a reference view thereof showing an example of the usage of the subject design.
The broken lines in the drawings depict unclaimed environmental subject matter. The regular broken lines are used to show unclaimed environmental subject matter. The dash-dot-dash broken lines are used to show a boundaries between claimed and unclaimed subject matter, and thus form no part of the claimed design.

(56) **References Cited**
U.S. PATENT DOCUMENTS
4,284,451 A * 8/1981 Conley B29C 73/10
156/97
D509,838 S * 9/2005 Wong D15/199
6,964,284 B2 * 11/2005 Eckhardt B29C 73/166
141/100
D574,866 S * 8/2008 Yoshida D15/199
D600,262 S * 9/2009 Stehle D15/199
D600,263 S * 9/2009 Eckhardt D15/199
7,798,183 B2 * 9/2010 Cegelski B29C 73/166
141/38

1 Claim, 12 Drawing Sheets

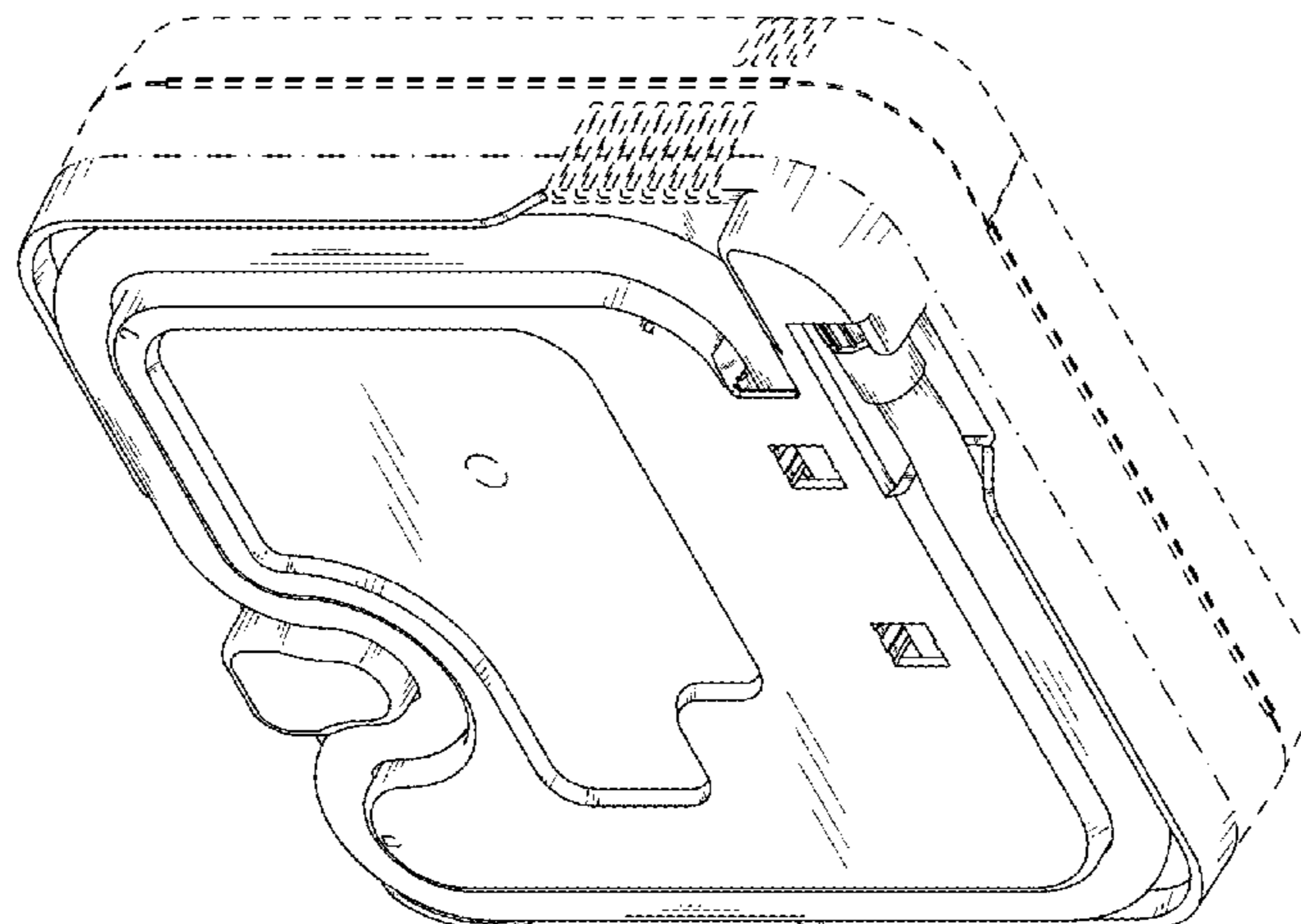

(56)

References Cited

U.S. PATENT DOCUMENTS

2010/0108186 A1* 5/2010 Yoshida B29C 73/166
141/38
2012/0231100 A1* 9/2012 Chou B29C 73/166
425/12
2013/0105055 A1* 5/2013 Chou B60S 5/043
152/416
2013/0199665 A1* 8/2013 Lolli B29C 73/166
141/38
2013/0228316 A1* 9/2013 Hong B29C 73/166
165/121
2013/0284312 A1* 10/2013 Chou B29C 73/166
141/38
2013/0284313 A1* 10/2013 Kojima B29C 73/166
141/38
2014/0209207 A1* 7/2014 Spindler B29C 73/166
141/38
2015/0059921 A1* 3/2015 Jhou B29C 73/166
141/38
2015/0197066 A1* 7/2015 Wong B60S 5/04
141/38
2016/0144672 A1* 5/2016 Wang B60C 23/001
141/38
2016/0288434 A1* 10/2016 Eckhardt B29C 73/166
2016/0311411 A1* 10/2016 Chou F04B 35/04
2017/0173900 A1* 6/2017 Kawatani B29C 73/166
2017/0313001 A1* 11/2017 Petrelli B29C 73/025

* cited by examiner

FIG. 1

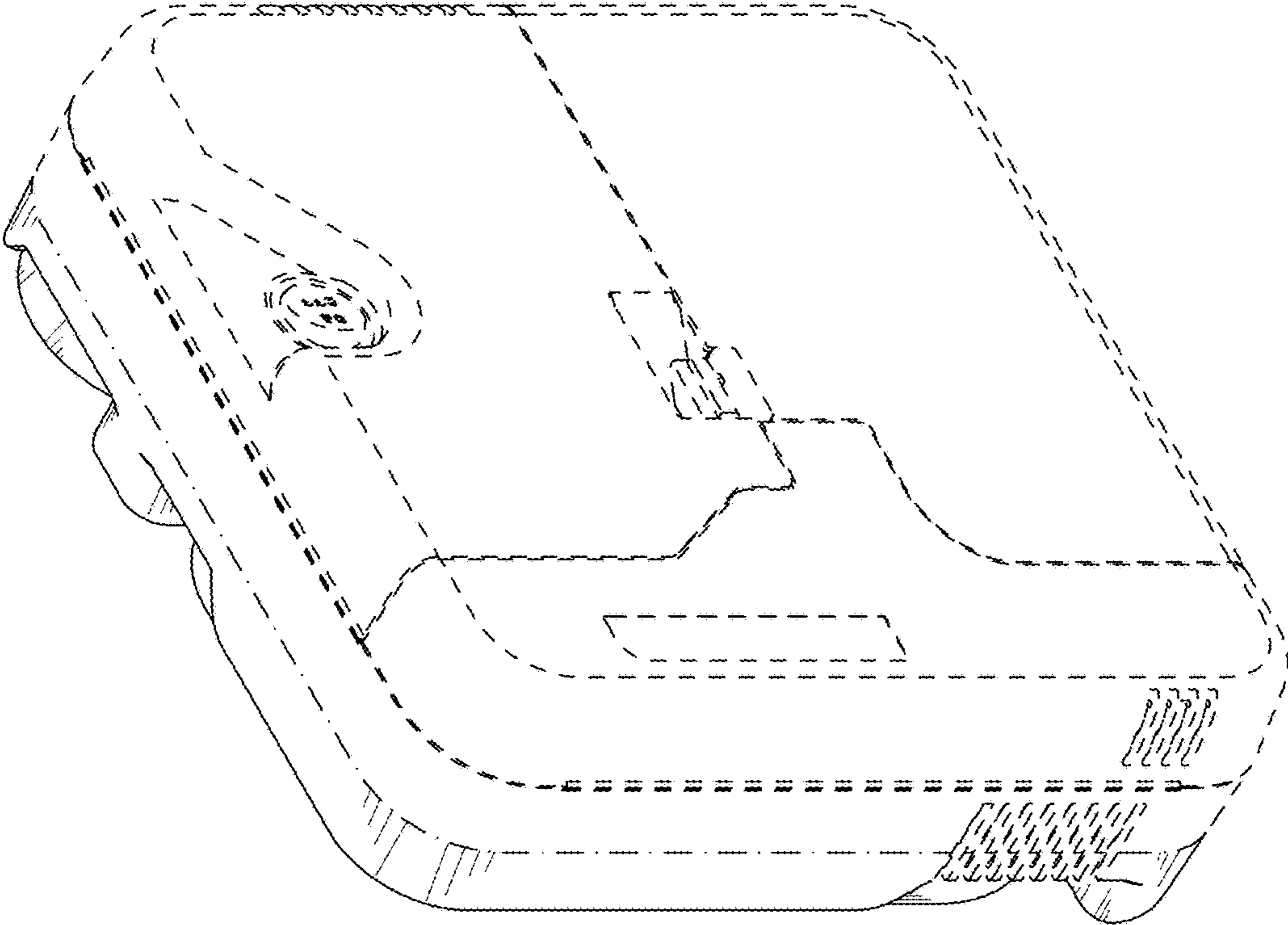

FIG. 2

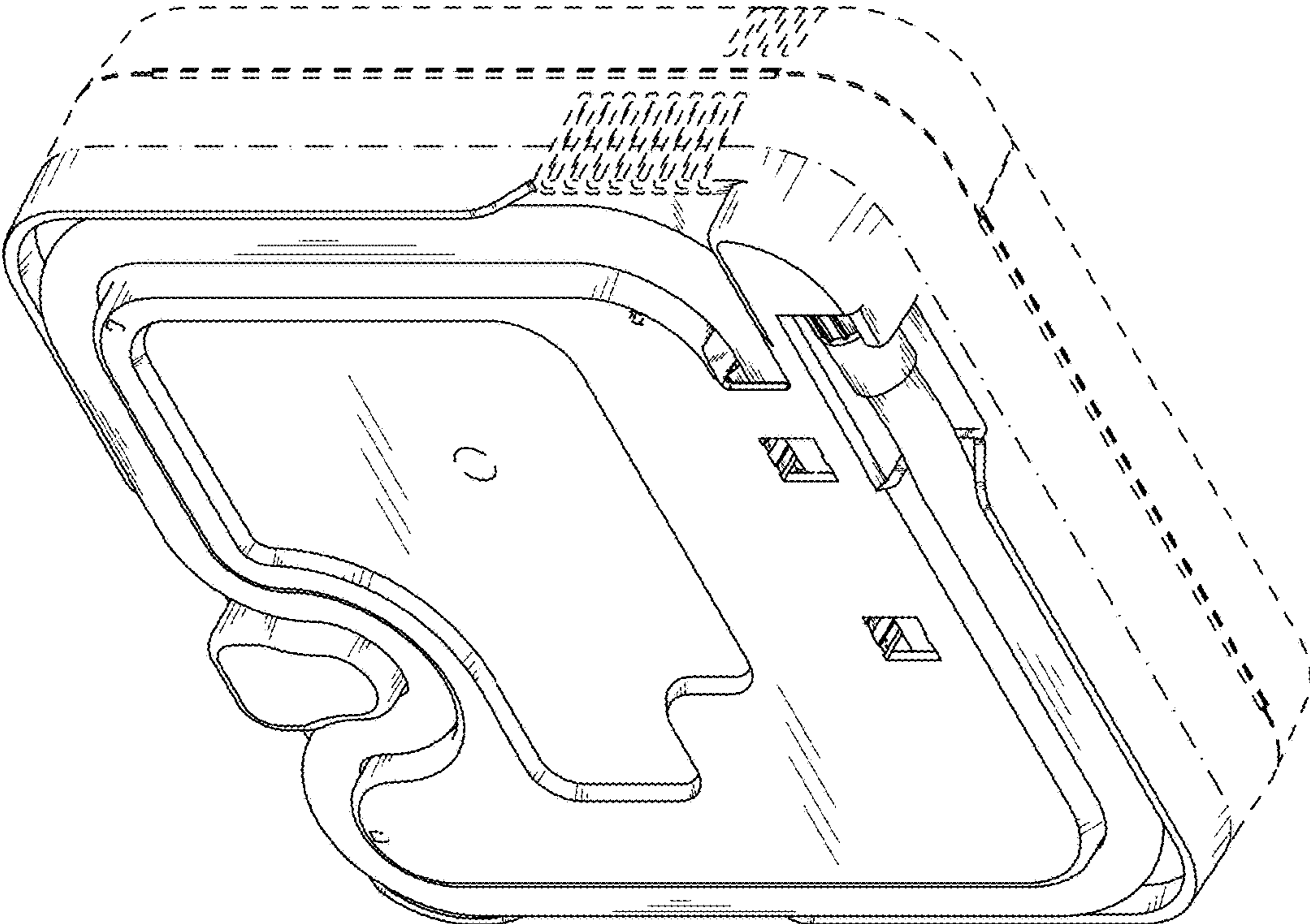

FIG. 3

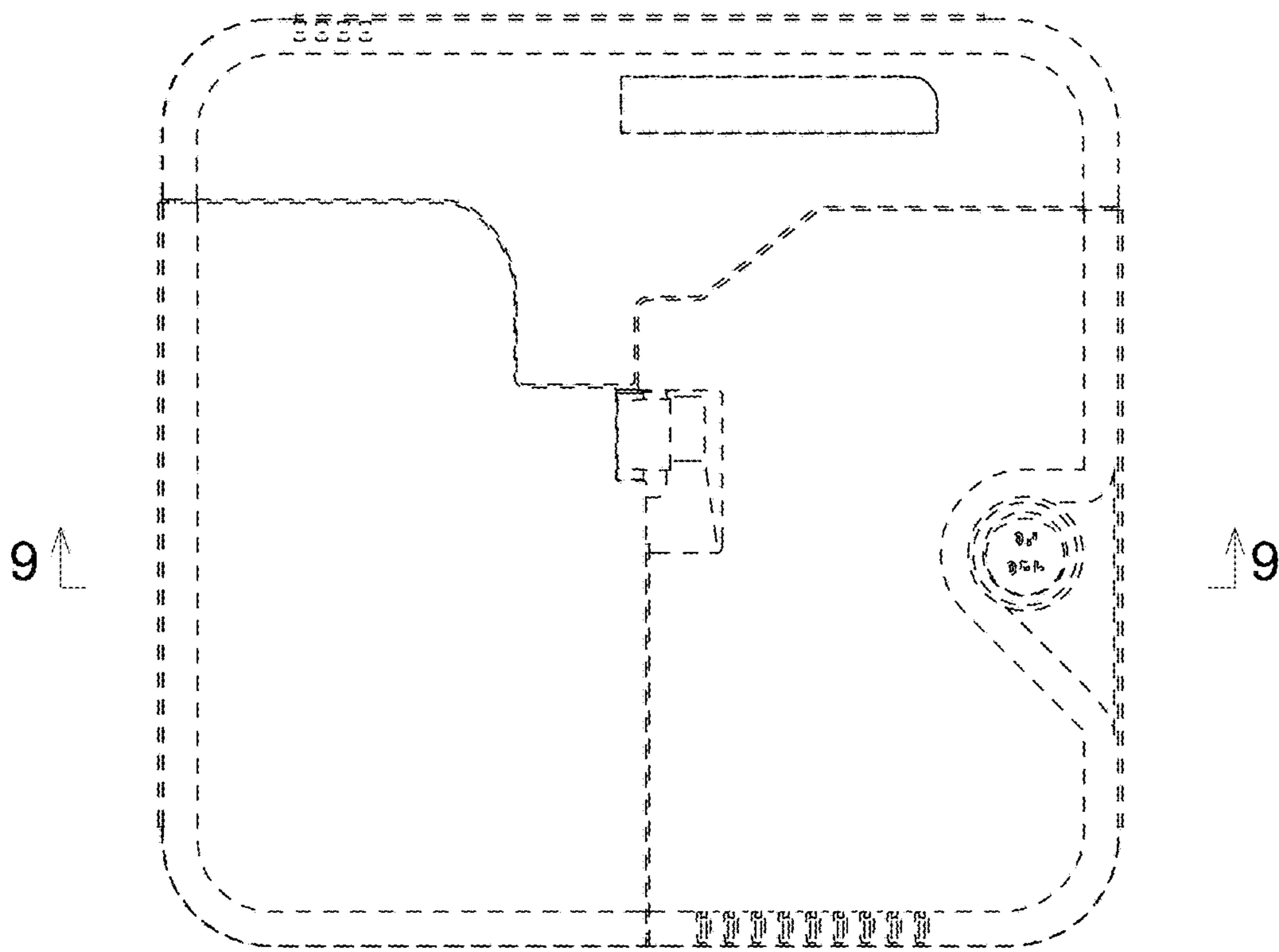

FIG. 4

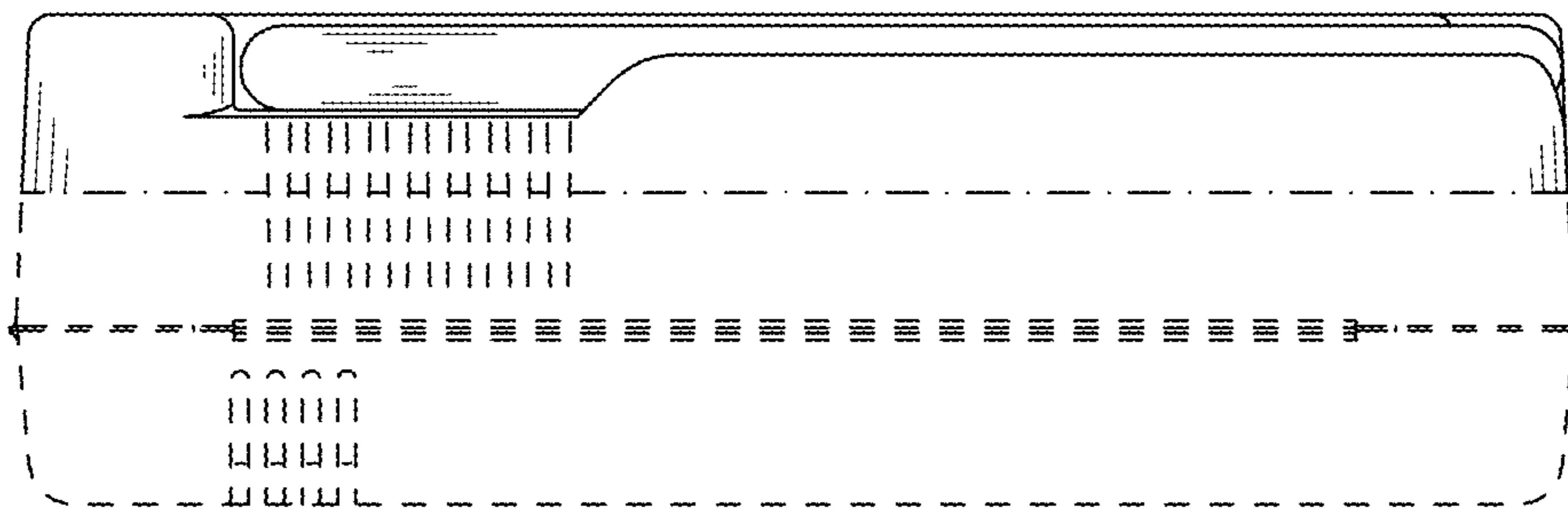

FIG. 5

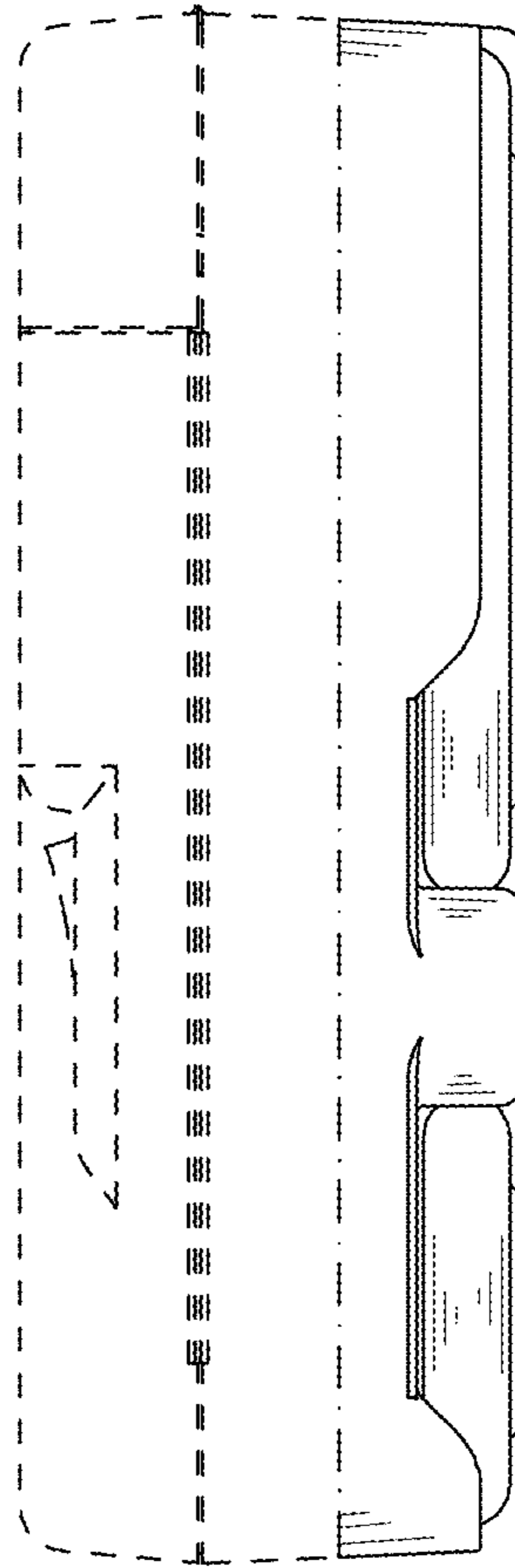

FIG. 6

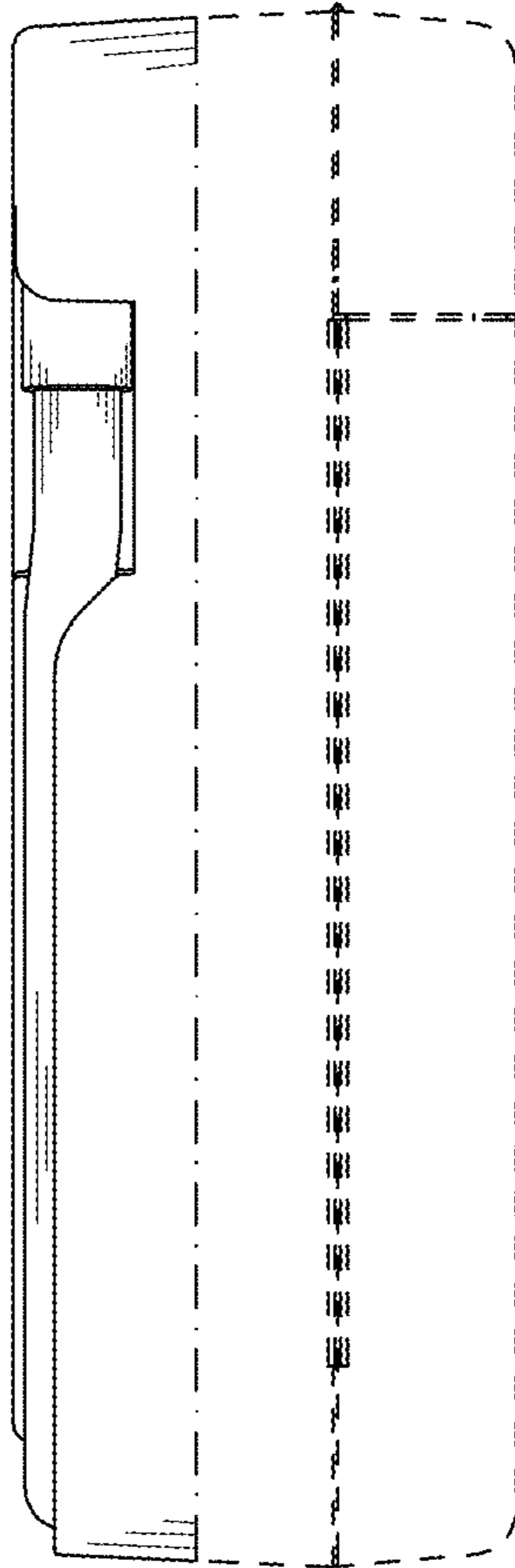

FIG. 7

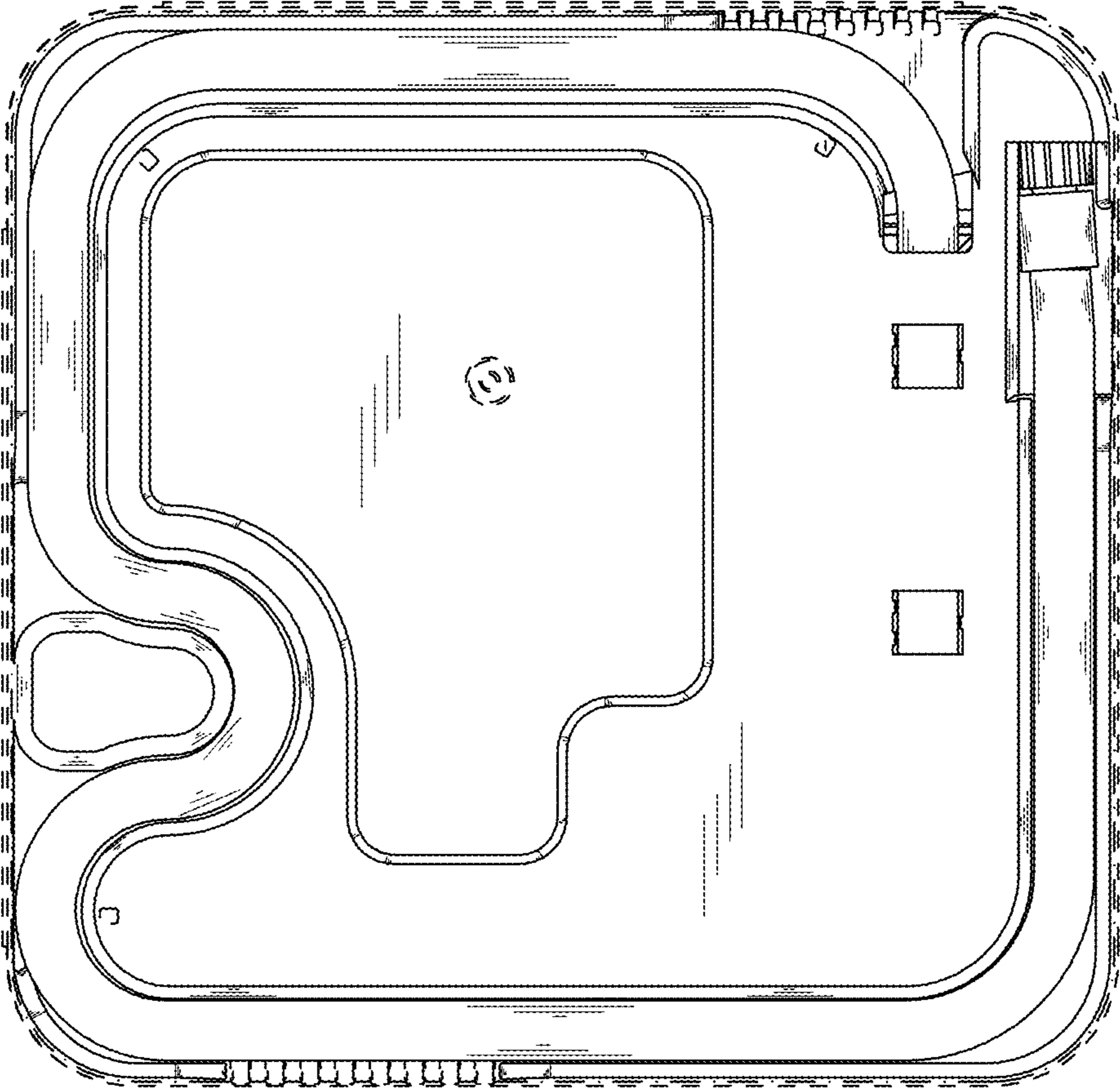

FIG. 8

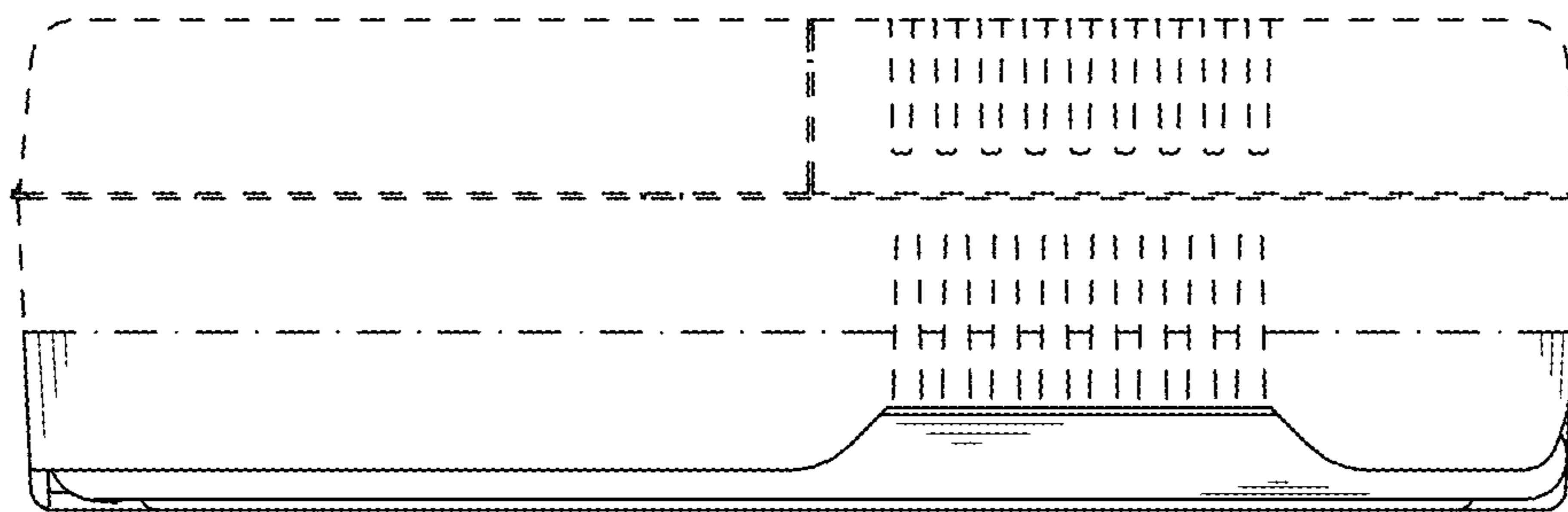

FIG. 9

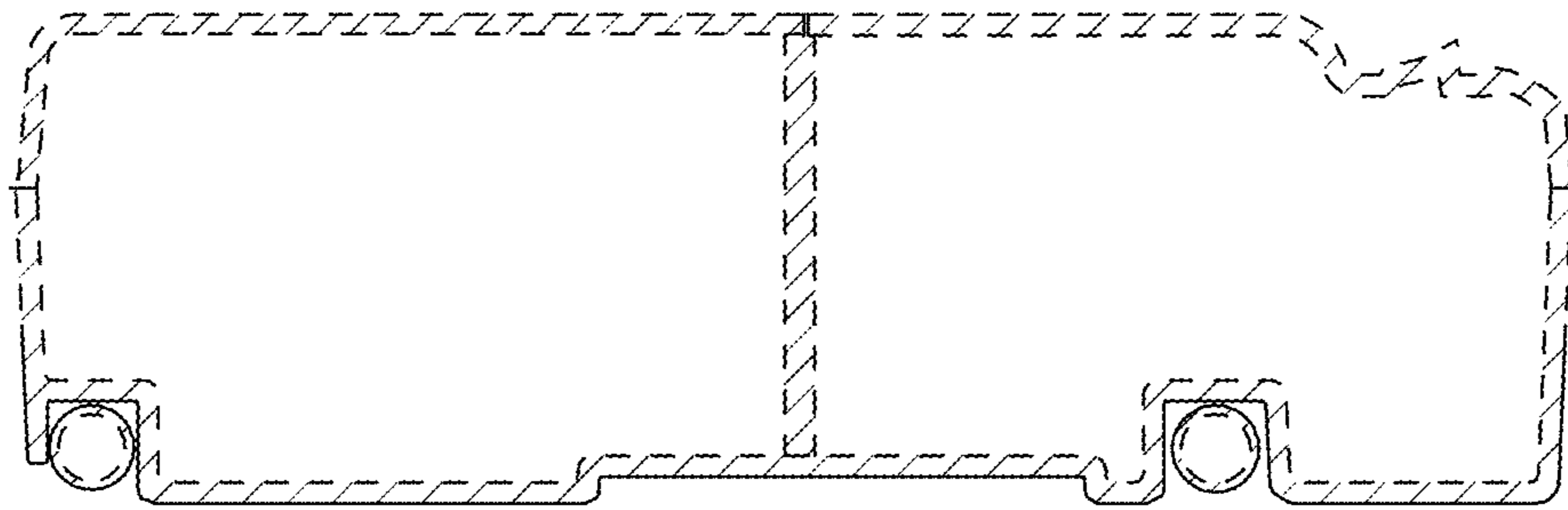

FIG. 10

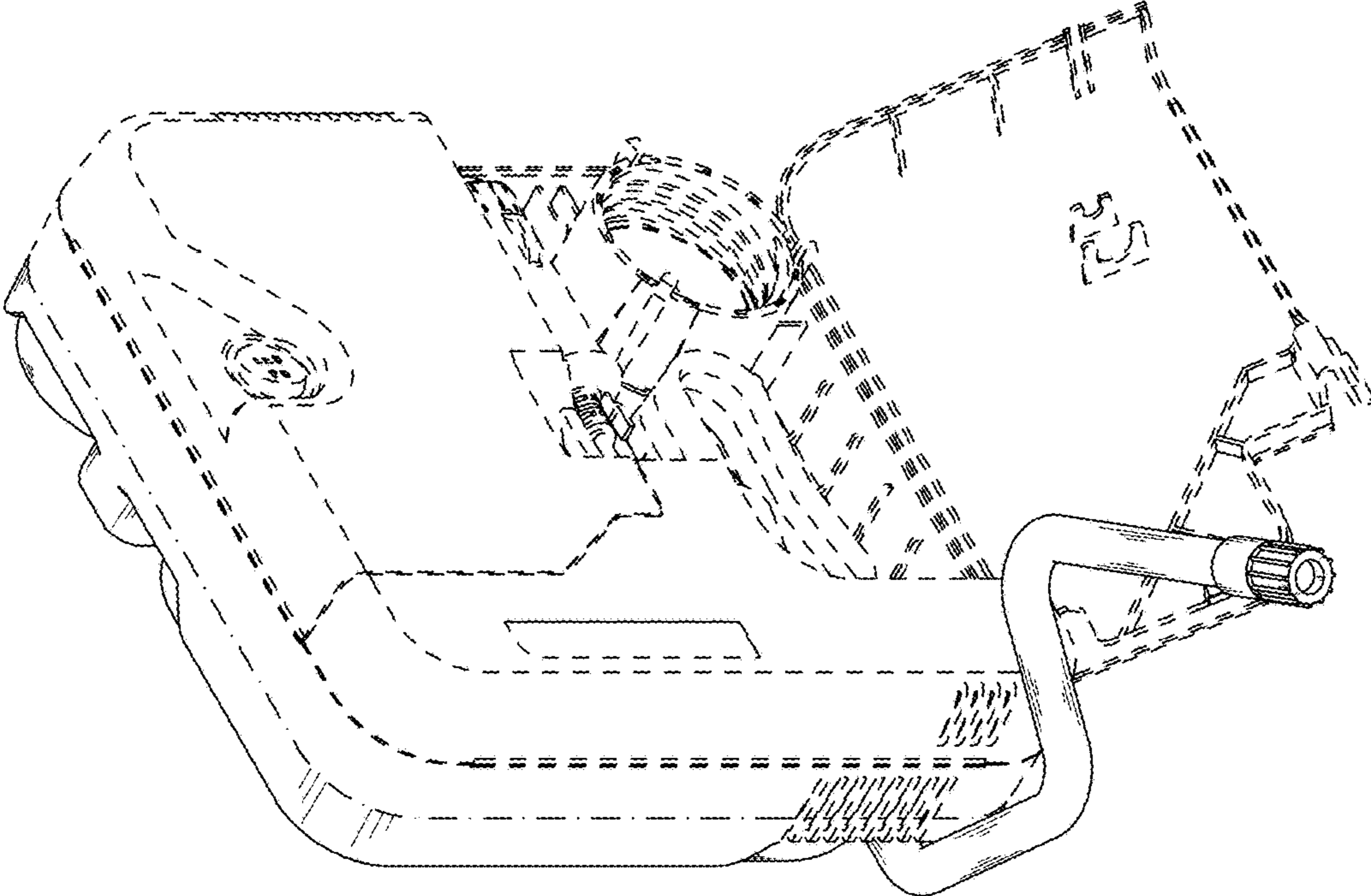

FIG. 11

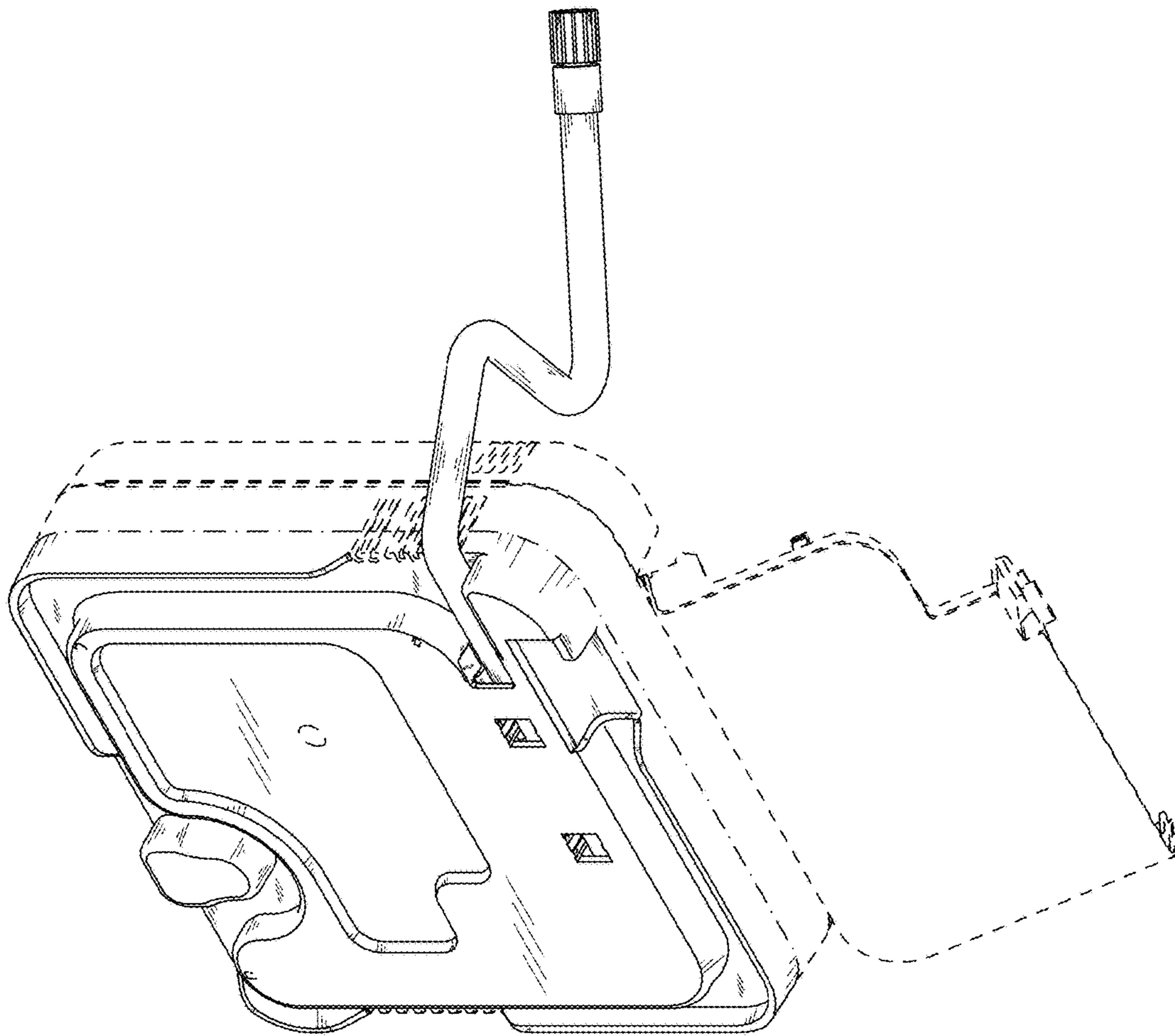

FIG. 12

