



US00D823102S

(12) **United States Design Patent** (10) **Patent No.:** **US D823,102 S**
Camilleri et al. (45) **Date of Patent:** **** Jul. 17, 2018**

(54) **SCREW FASTENER** 6,152,666 A * 11/2000 Walther F16B 25/0015
411/311
(71) Applicant: **ILLINOIS TOOL WORKS INC.,** 6,715,720 B2 * 4/2004 Finn F16G 11/046
Glenview, IL (US) 248/317
6,789,989 B2 9/2004 Walther
(72) Inventors: **Mark Anthony Camilleri,** Oatley 6,926,484 B2 8/2005 Kram et al.
(AU); **Bryan Hugh Marshall,** 7,883,307 B2 2/2011 Pippard et al.
Turramurra (AU) 8,192,123 B2 6/2012 Ernst et al.
2006/0251493 A1 * 11/2006 Buhl F16B 25/0015
411/386
(73) Assignee: **Illinois Tool Works Inc.,** Glenview, IL 2009/0269164 A1 10/2009 Gonciarz et al.
(US) 2010/0158634 A1 6/2010 Walther
2010/0172718 A1 7/2010 Gong et al.
(**) Term: **15 Years** 2011/0006454 A1 1/2011 Kawashiri
2011/0064540 A1 * 3/2011 Walther F16B 35/065
411/399

(21) Appl. No.: **29/594,365**

(Continued)

(22) Filed: **Feb. 17, 2017**

Primary Examiner — Sandra S Snapp

Assistant Examiner — Ieisha N Price

(30) **Foreign Application Priority Data**

(74) *Attorney, Agent, or Firm* — Neal, Gerber & Eisenberg LLP

Aug. 31, 2016 (AU) 201614800

(51) **LOC (11) Cl.** **08-08**

(57) **CLAIM**

(52) **U.S. Cl.**

The ornamental design for a screw fastener, as shown and described.

USPC **D8/387**

(58) **Field of Classification Search**

DESCRIPTION

USPC D8/349, 382, 385, 387, 388, 391, 393,
D8/397, 399

FIG. 1 is a top perspective view of a screw fastener of our new design.

CPC F16B 15/00; F16B 23/00; F16B 23/003;

F16B 23/0061; F16B 23/0007; F16B

25/00; F16B 25/0036; F16B 25/103;

F16B 25/0015; F16B 35/04; F16B 35/06;

F16B 35/041; F16B 35/065; F16B

35/048; Y10S 411/919

See application file for complete search history.

FIG. 2 is a bottom perspective view of the screw fastener of FIG. 1.

FIG. 3 is a front view of the screw fastener of FIG. 1.

FIG. 4 is a left side view of the screw fastener of FIG. 1.

FIG. 5 is a right side view of the screw fastener of FIG. 1.

FIG. 6 is a top view of the screw fastener of FIG. 1; and,

FIG. 7 is a bottom view of the screw fastener of FIG. 1.

The broken lines shown in the Figures are included for the purpose of illustrating portions of the screw fastener and form no part of the claimed design.

(56) **References Cited**

U.S. PATENT DOCUMENTS

5,100,274 A 3/1992 Hasan et al.

5,413,444 A 5/1995 Thomas et al.

5,919,020 A * 7/1999 Walther F16B 5/0275

411/368

1 Claim, 4 Drawing Sheets

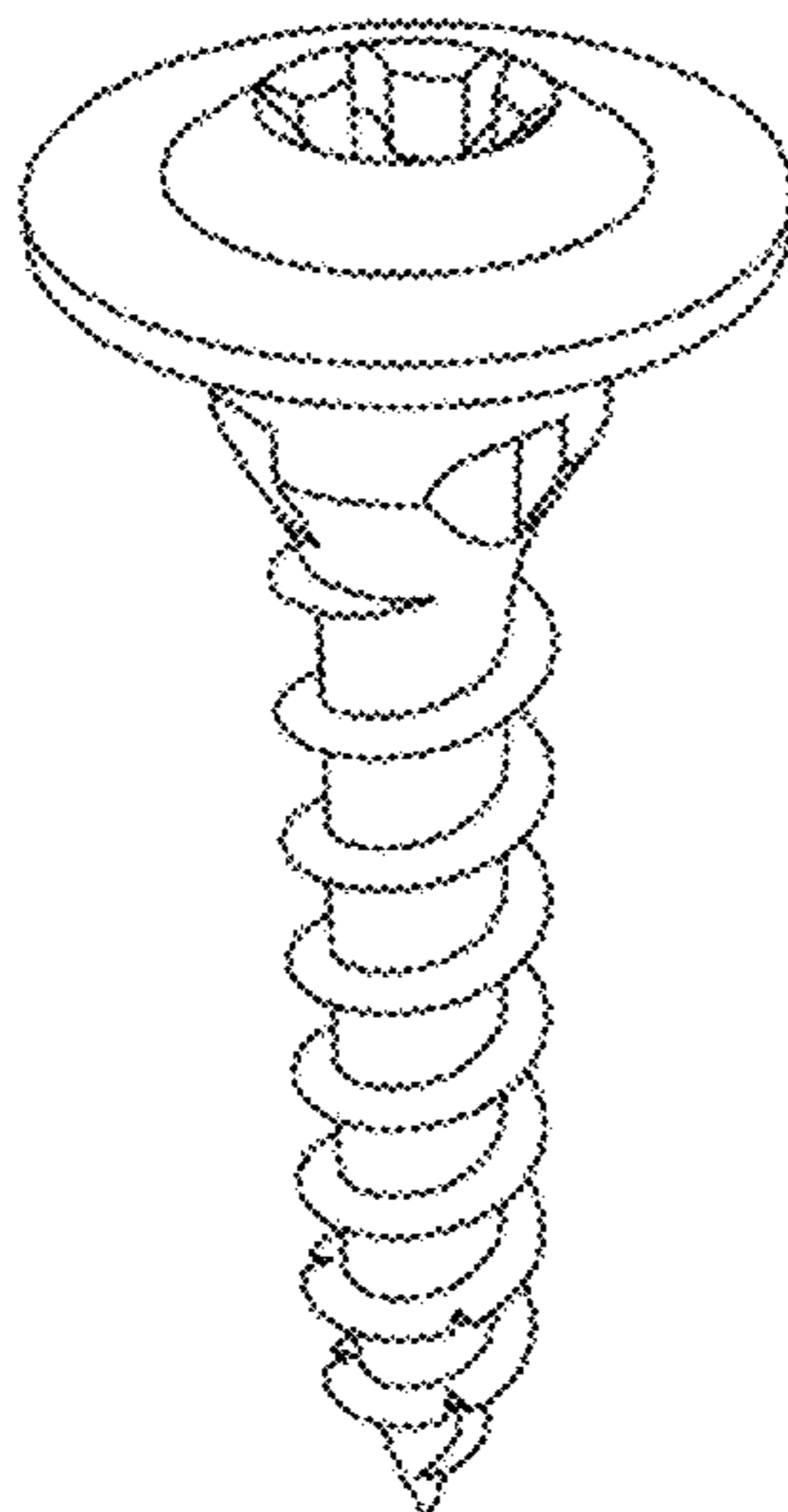

(56)

References Cited

U.S. PATENT DOCUMENTS

2011/0211934 A1* 9/2011 Walther F16B 25/0015
411/387.1
2012/0003059 A1* 1/2012 Tamaki F16B 35/048
411/166
2012/0266560 A1 10/2012 Panasik et al.
2013/0084144 A1* 4/2013 Walther F16B 25/0015
411/393
2014/0328646 A1* 11/2014 Muller F16B 25/0015
411/424
2016/0290382 A1 10/2016 Dill
2016/0316846 A1* 11/2016 Salvetti A42B 3/125

* cited by examiner

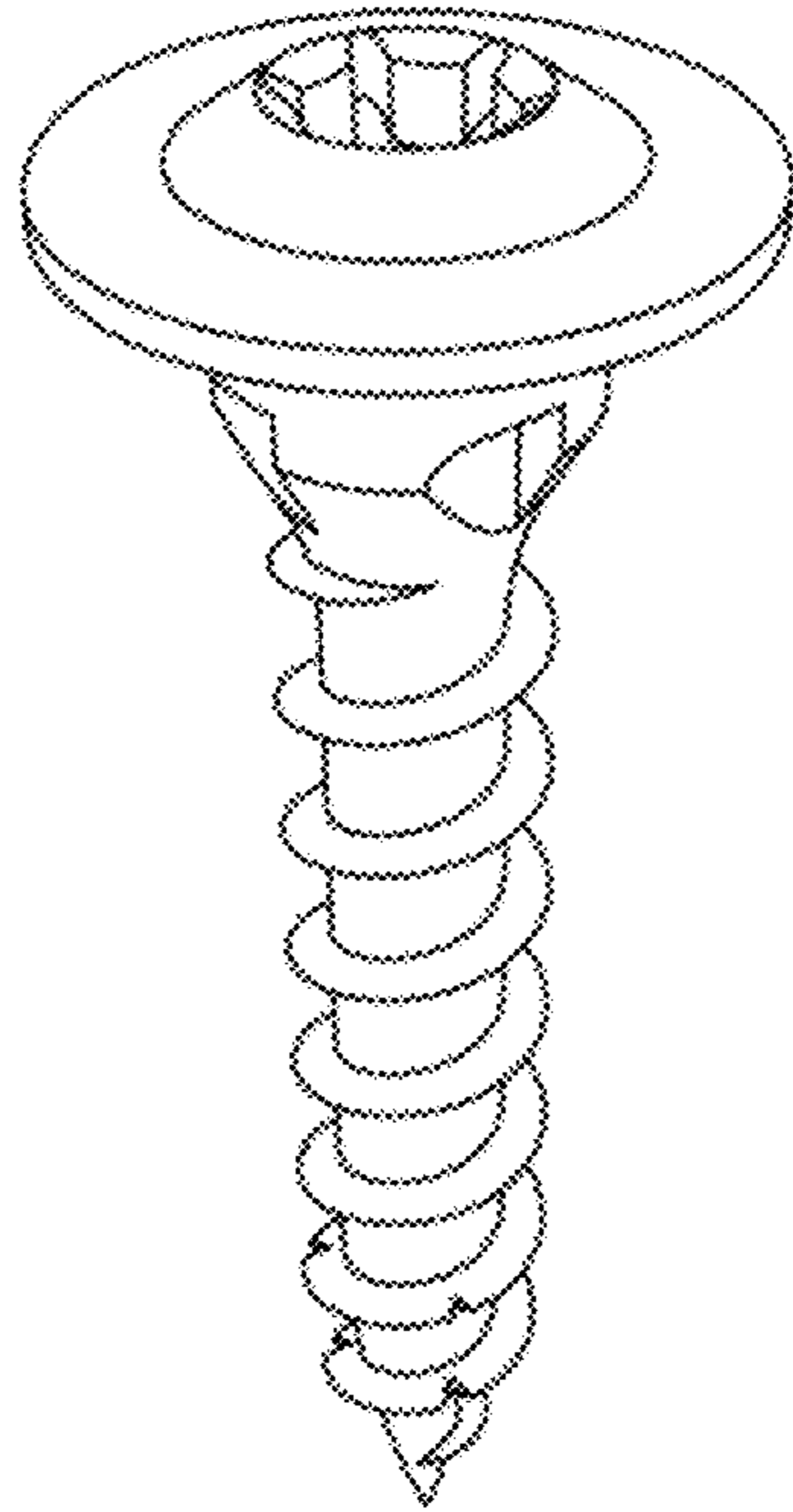

FIGURE 1

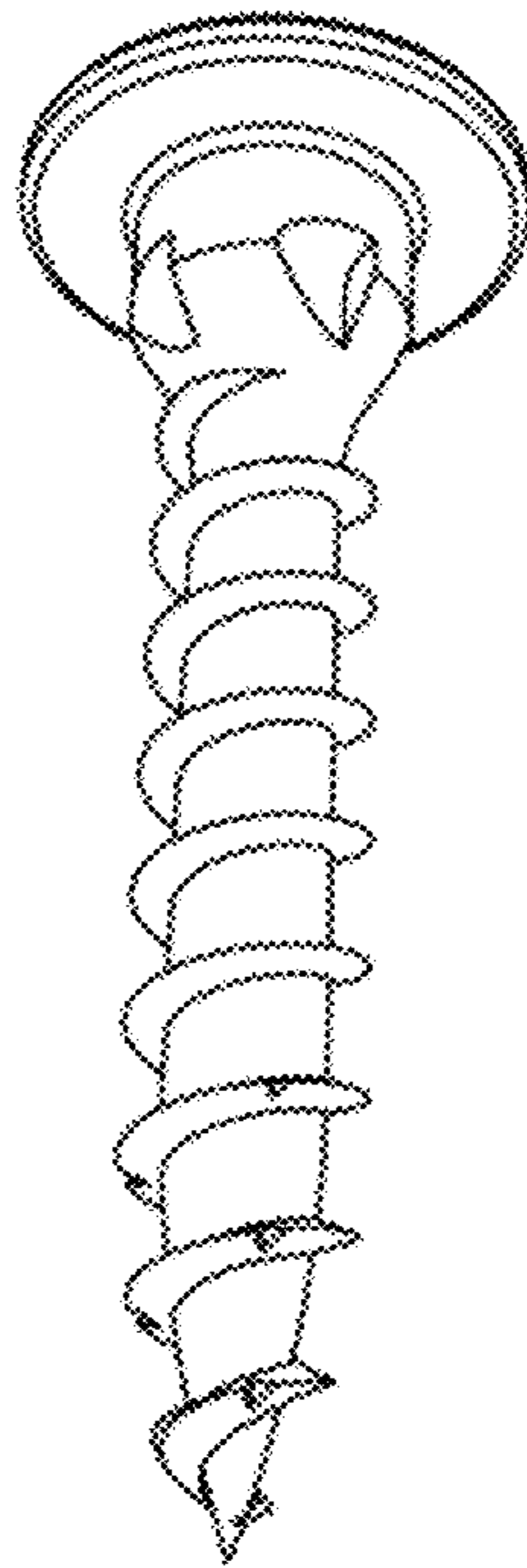

FIGURE 2

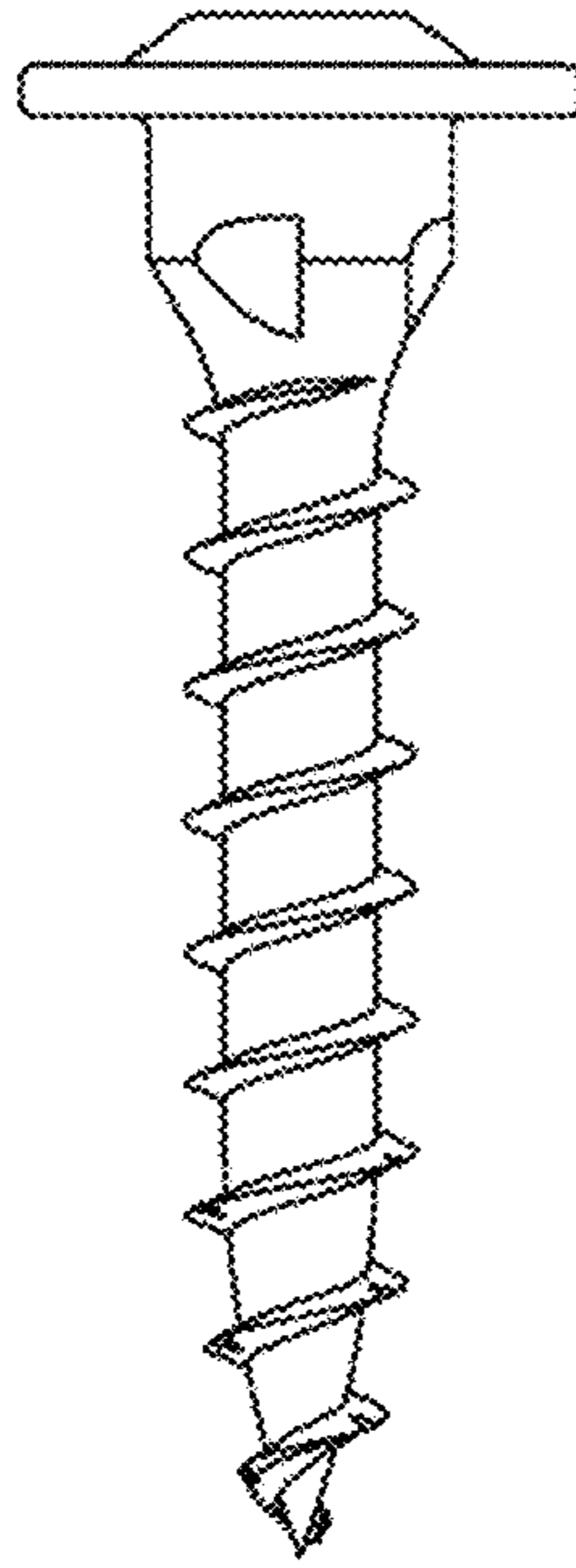

FIGURE 3

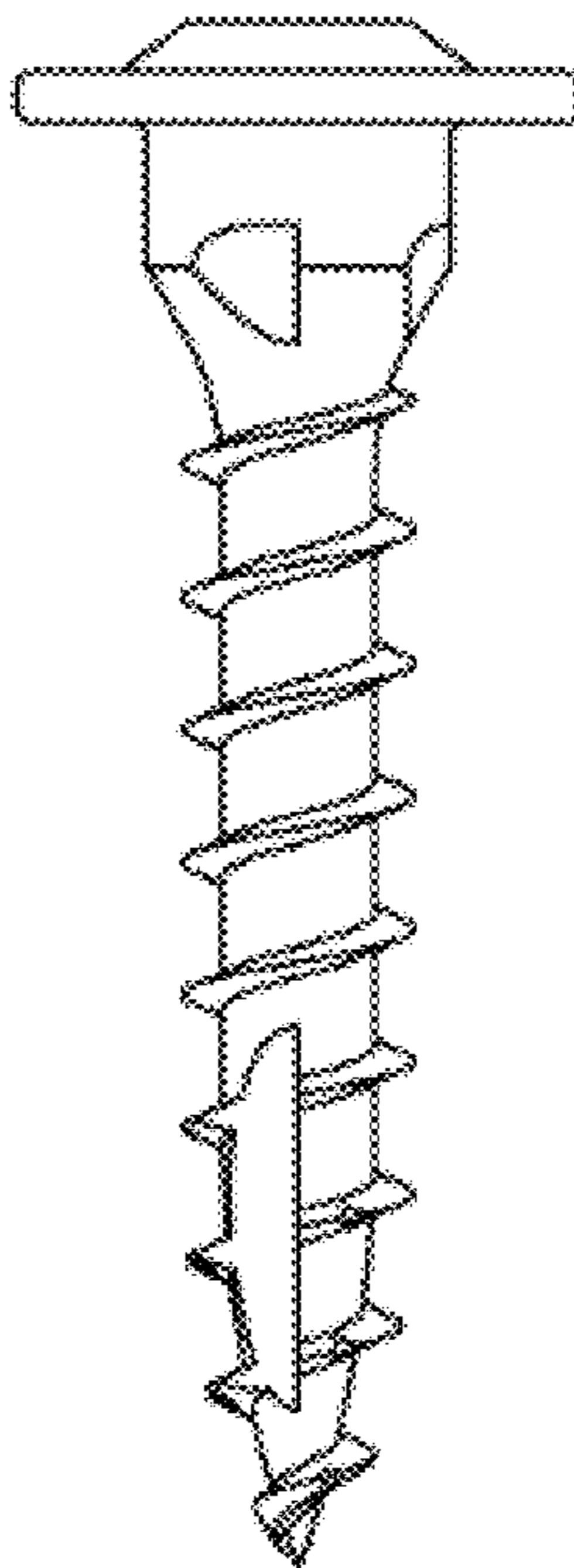

FIGURE 4

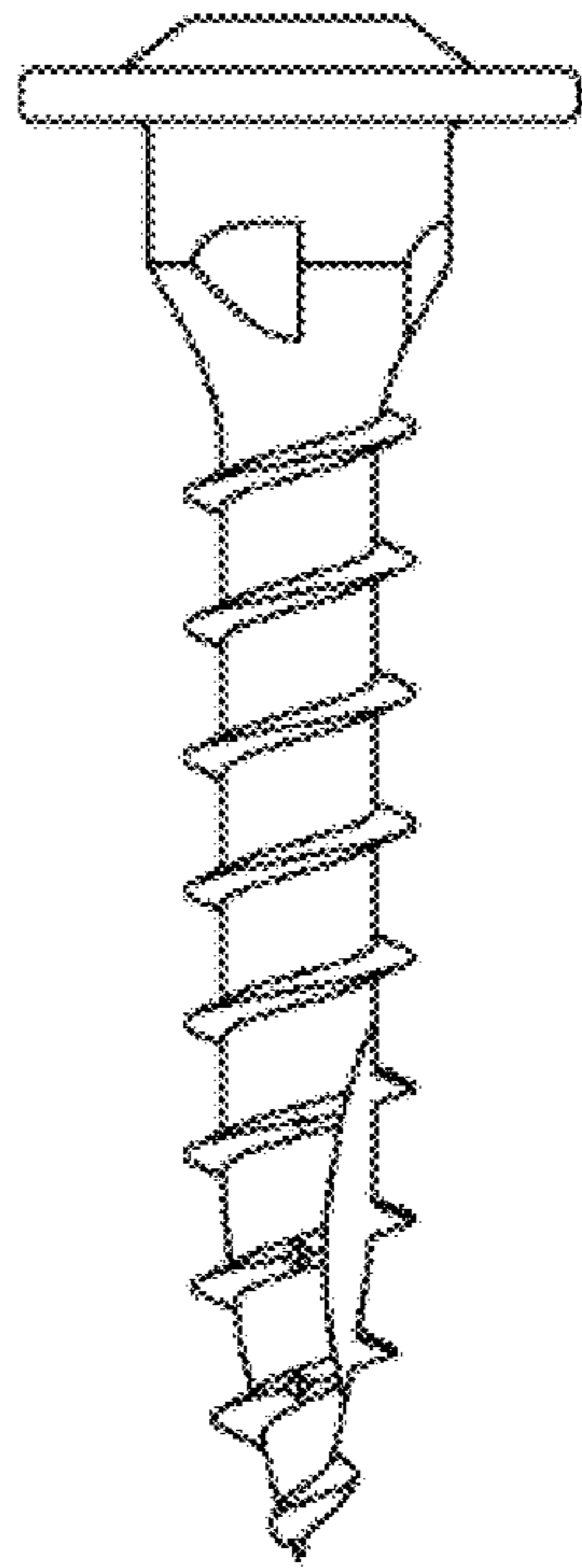

FIGURE 5

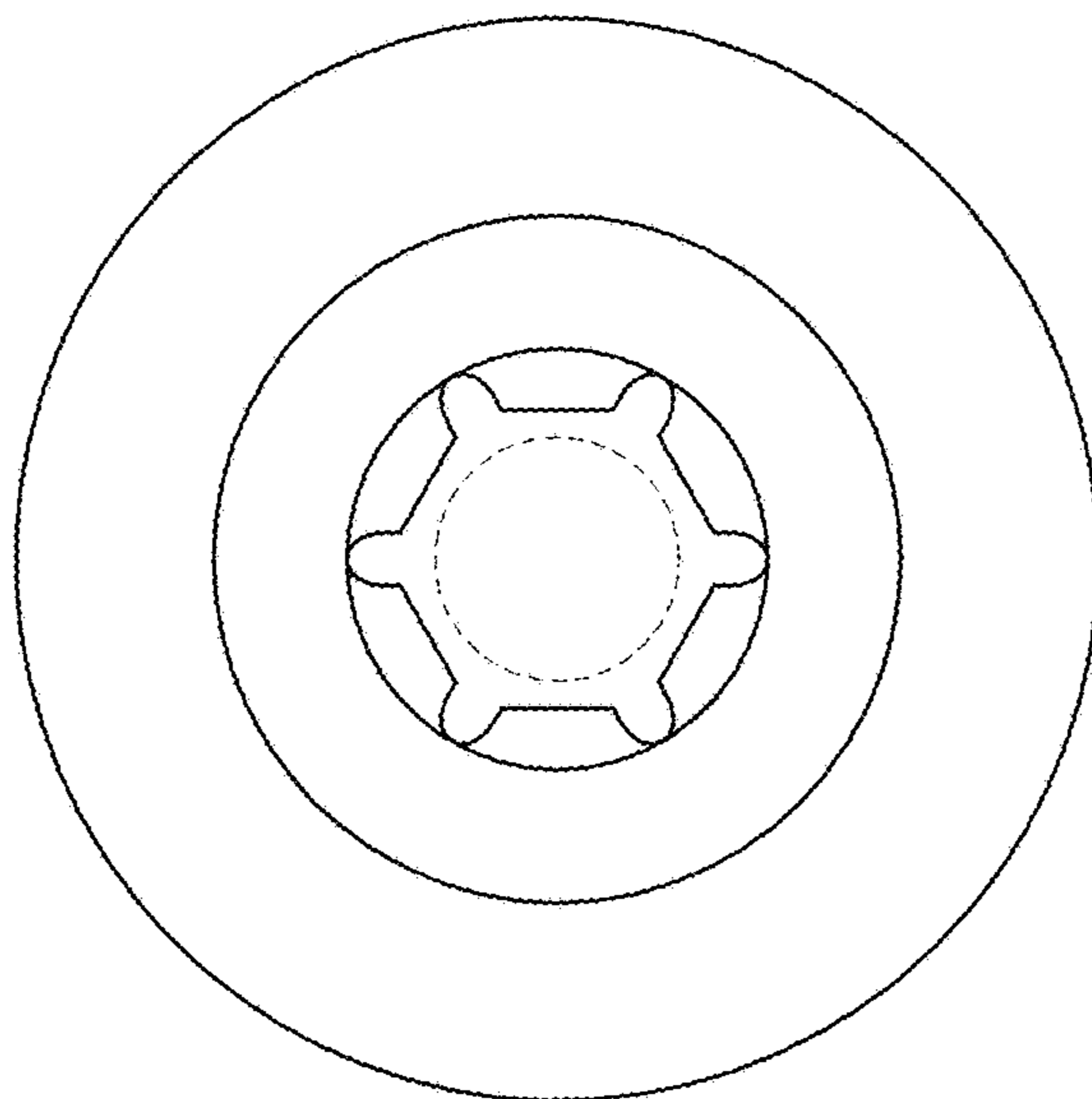

FIGURE 6

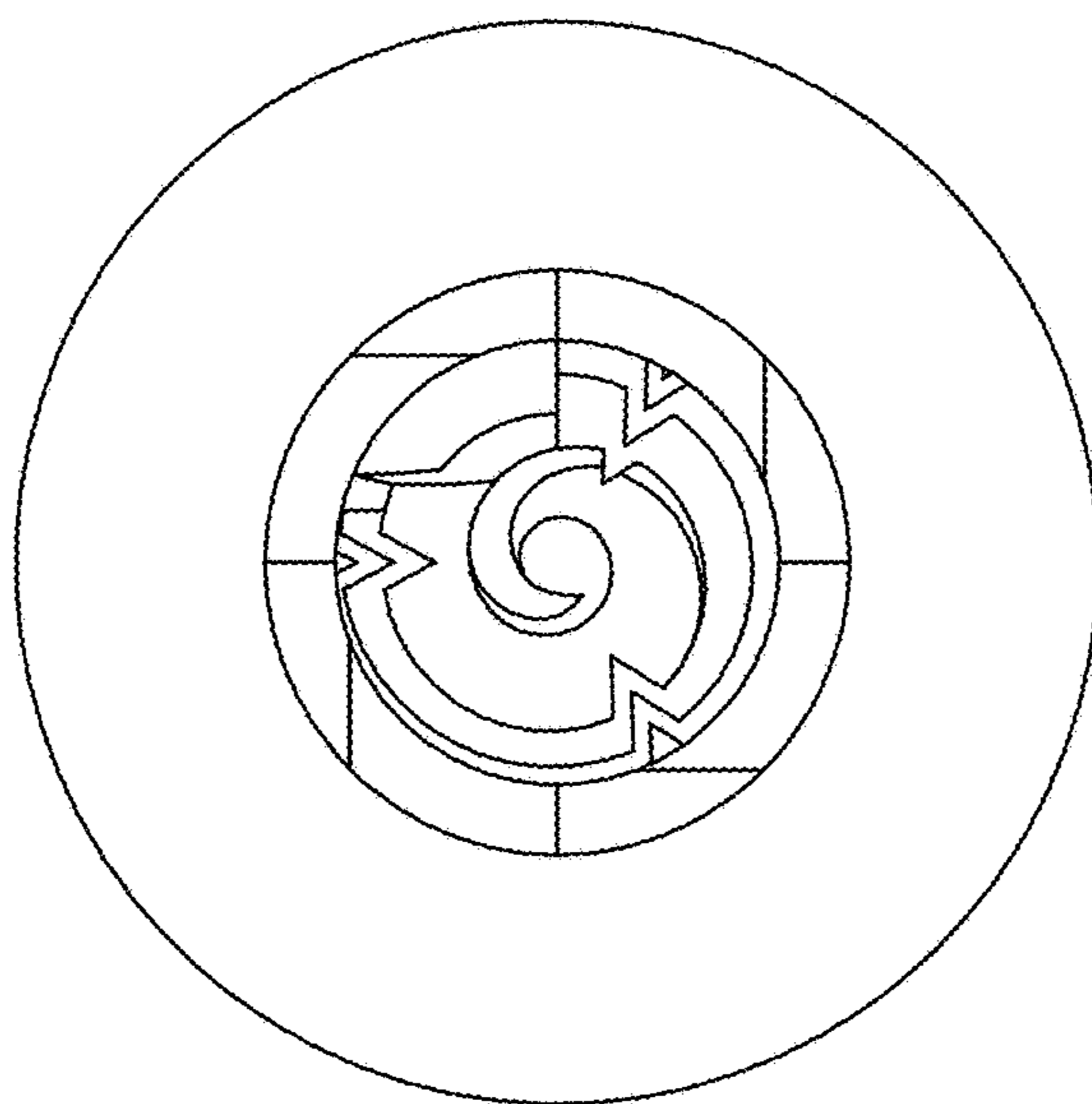

FIGURE 7