



US00D822885S

(12) **United States Design Patent** (10) **Patent No.:** **US D822,885 S**
Tweel et al. (45) **Date of Patent:** **** Jul. 10, 2018**

(54) **LIGHT FIXTURE**

- (71) Applicant: **ABL IP Holding LLC**, Atlanta, GA (US)
- (72) Inventors: **Patrick M. Tweel**, Atlanta, GA (US); **Aaron Feldman**, Atlanta, GA (US); **Matthew Scott Hoch**, McDonough, GA (US); **John T. Hickok**, Social Circle, GA (US)
- (73) Assignee: **ABL IP Holding LLC**, Atlanta, GA (US)
- (**) Term: **15 Years**
- (21) Appl. No.: **29/623,817**
- (22) Filed: **Oct. 27, 2017**

Related U.S. Application Data

- (62) Division of application No. 29/561,794, filed on Apr. 20, 2016, now Pat. No. Des. 807,567.
- (51) **LOC (11) Cl.** **26-99**
- (52) **U.S. Cl.**
USPC **D26/118**
- (58) **Field of Classification Search**
USPC D26/74, 24, 72, 75, 76, 78, 79, 81, 82, D26/88, 89, 91, 113, 118, 119, 120, 138, D26/141, 142
CPC F21V 21/04; F21V 21/041; F21V 7/005; F21Y 2111/002; F21S 8/026; F21S 8/02
See application file for complete search history.

(56) **References Cited**

U.S. PATENT DOCUMENTS

- D130,570 S * 12/1941 Borkland D26/76
- D397,819 S 9/1998 Thorton, Jr.
- 5,988,829 A 11/1999 Holder

(Continued)

OTHER PUBLICATIONS

“2x2 2x4 LED Troffer,” <<http://www.led-wall-pack.com/indoor-led-lighting/led-volumetric-troffer-light/2017-newest-etl-dlc-v4-0-premium-led-ceiling.html>>, site visited Jun. 20, 2017, Nov. 29, 2015.

(Continued)

Primary Examiner — Brian N. Vinson
(74) *Attorney, Agent, or Firm* — Kilpatrick Townsend & Stockton LLP

(57) **CLAIM**

The ornamental design for a light fixture, as shown and described.

DESCRIPTION

FIG. 1 is a bottom perspective view of the light fixture. FIG. 2 is a top perspective view of the light fixture of FIG. 1.

FIG. 3 is a right side elevation view of the light fixture of FIG. 1, it being understood that the left side elevation view is identical to the right side elevation view.

FIG. 4 is a front elevation view of the light fixture of FIG. 1, it being understood that the rear elevation view is identical to the front elevation view.

FIG. 5 is a top plan view of the light fixture of FIG. 1; and, FIG. 6 is a bottom plan view of the light fixture of FIG. 1. Portions or features of the light fixture not shown in the drawings form no part of the claimed design. The evenly dotted broken lines in the drawings illustrate unclaimed features of the claimed design that form no part of the claimed design. The dash-dot-dot-dash broken lines in the drawings represent borders of unclaimed portions of the design and form no part of the claimed design. The dash-dot-dash-dot broken lines in the drawings represent symbolic breaks along the fixture length and/or width. The appearance of any portion of the light fixture between these breaks forms no part of the claimed design.

1 Claim, 5 Drawing Sheets

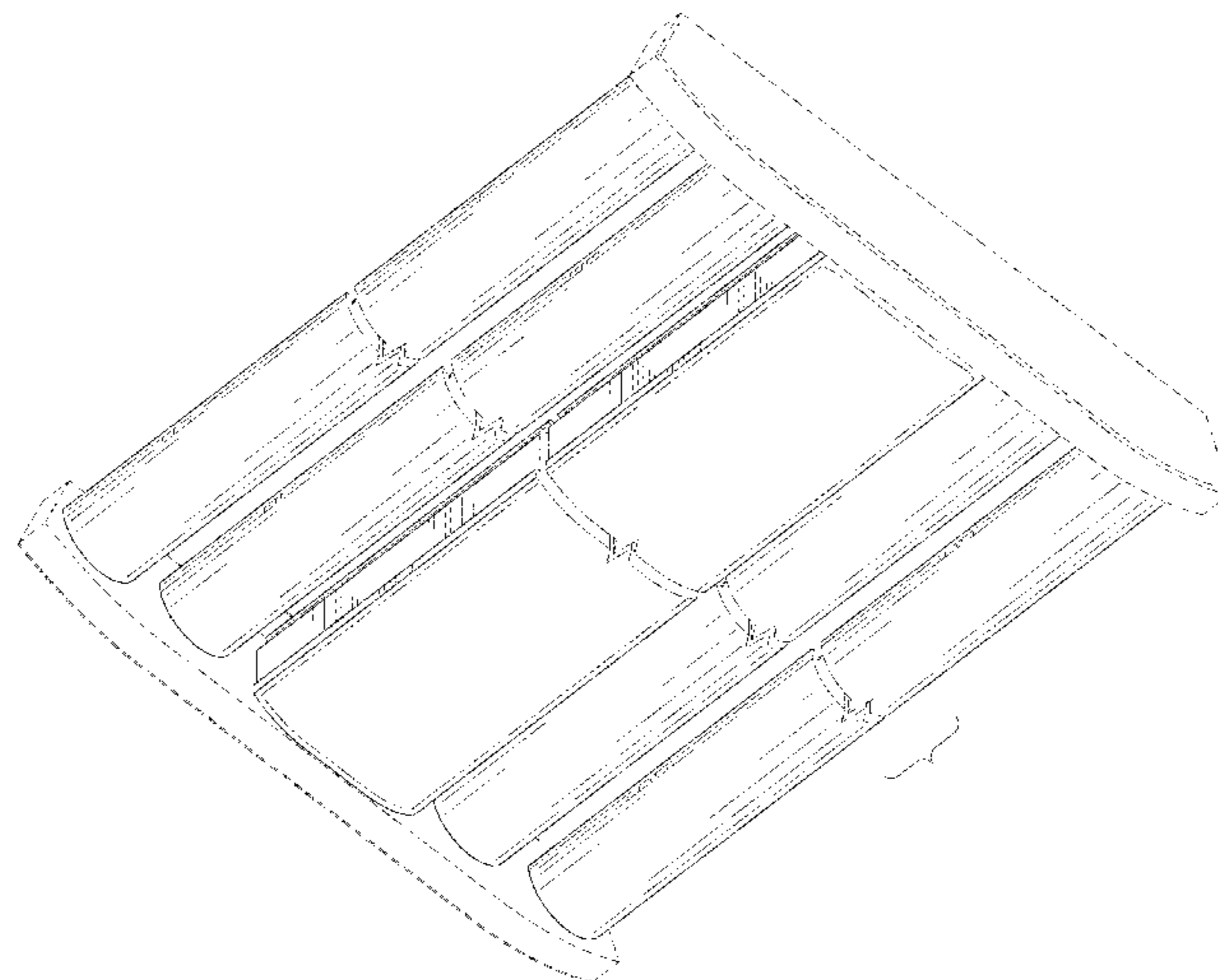

(56)

References Cited

U.S. PATENT DOCUMENTS

D496,121	S	9/2004	Santoro	
D561,383	S *	2/2008	Hukle	D26/120
7,490,960	B1 *	2/2009	Fiorino	F21S 8/02 362/148
D595,894	S	7/2009	Verfuether et al.	
D604,000	S	11/2009	Fowler, Jr. et al.	
D673,324	S *	12/2012	Mayfield, III	D26/120
D678,597	S	3/2013	Lehman et al.	
8,506,121	B2	8/2013	van Laanen et al.	
D696,449	S	12/2013	Boyer et al.	
D701,341	S *	3/2014	Mayfield, III	D26/74
D703,858	S	4/2014	Miller	
D729,435	S *	5/2015	Arndt	D26/118
D739,593	S *	9/2015	Mayfield, III	D26/118
D739,977	S	9/2015	Boyer et al.	
D762,909	S	8/2016	Shi	
9,416,954	B2	8/2016	Miller	
D767,193	S	9/2016	Jung	
D784,594	S	4/2017	Stolte	
D786,471	S *	5/2017	Snell	D26/74
2012/0212956	A1	8/2012	Chen	
2013/0063948	A1	3/2013	Ishii	
2013/0294072	A1	11/2013	Miller	
2014/0313719	A1	10/2014	Wang et al.	
2015/0016108	A1	1/2015	Howe	
2015/0159839	A1	6/2015	Howe	

OTHER PUBLICATIONS

“Albeo™ LED Luminaire High Bay Lighting (ABV—Series),” GE Lighting, Feb. 16, 2016 (6 pages).
 “Albeo™ LED Luminaire Modular High & Low Bay Lighting (ABHX—Series),” GE Lighting Solutions, May 1, 2013, (8 pages).
 “Albeo™ LED Luminaire Heavy Industrial High Bay & Low Bay Lighting (ABRI—Series)” Brochure, GE Lighting, Retrieved from the internet: www.gelighting.com, 2016, 6 pages.
 “Albeo™ LED Luminaire Heavy Industrial High Bay & Low Bay Lighting (ABRI—Series),” GE Lighting, Retrieved from the internet: www.gelighting.com, 2016, 2 pages.
 “Albeo™ LED Luminaire Heavy Industrial High Bay Lighting (ABRI—Series),” GE Lighting, Installation Guide, 2014, 4 pages.
 “Announcing the Albeo™ ABR1 Heavy Industrial High Bay from GE,” GE Lighting, Nov. 20, 2015, 2 pages.
 “Award Winning of High Efficacy LED Fixtures for High and Medium Bay Applications,” Flextronics X, Product Guide, Lusio® Essentials Series v 2.1, 2014 (60 pages).
 “Big Ass Light High Bay LED,” Retrieved from the internet: Bigasslight.com.au, Jul. 6, 2015, 3 pages.
 “Enjoy flexibility and savings along with quality illumination; An economical LED high bay,” Philips Lighting, 2015, 8 pages.
 “Get more from the top: Experience unmatched energy savings in high and low bay environments with Albeo™ LED Luminaires,” Current powered by GE, 2016, 8 pages.

“HBLED High Bay LED Luminaire,” Metalux, Eaton Powering Business Worldwide, 2015 (4 pages).
 “LED Features and Specification,” Orion ISON™ High Bay, orionlighting.com, 2015 (2 pages).
 “Low Profile Channel LED Fixture or Retrofit,” Industrial Lighting Products (13 pages).
 “Lusio® Essential Aisle Lighter Performance Line,” Flex, www.flextronics.com/lighting, 2015 (2 pages).
 “Lusio® Essential Series Aisle Lighter,” Flextronics X, www.flextronics.com/lighting, 2014 (2 pages).
 “Made to Order: Imagine lighting as versatile as the industries it serves,” Industrial Solutions, Believed to be available at least as early as Feb. 1, 2015, 15 pages.
 “Metalux Industrial LED Luminaires,” Eaton Powering Business Worldwide, Retrieved from the internet: <http://www.cooperindustries.com/content/dam/public/lighting/products/documents/metalux/brochures/BR507005EN-Mx-IndLED-bro.pdf>, 51 pages.
 “The Big Ass Inverted 20K LED,” Retrieved from the internet: Bigasslight.com, Jun. 24, 2015, 2 pages.
 Phillips, “IntelliWhite LED Lighting,” Color Kinetics, available online at <http://www.colorkinetics.com/ls/intelliwhite/intelliwhite.html>, May 16, 2014, 1 page.
 Notice of Allowance for U. S. Appl. No. 29/565,090, dated Jun. 9, 2017, 10 pages.
 Restriction Requirement for U.S. Appl. No. 29/567,476, dated Jun. 27, 2017, 8 pages.
 Non-Final Office Action for U.S. Appl. No. 29/567,207, dated Jul. 3, 2017, 14 pages.
 Response to Restriction Requirement for U.S. Appl. No. 29/567,476, filed Jul. 26, 2017, 5 pages.
 Restriction Requirement for U.S. Appl. No. 29/561,794, dated Aug. 1, 2017, 13 pages.
 Restriction Requirement for U.S. Appl. No. 29/561,838, dated Aug. 1, 2017, 13 pages.
 Non-Final Office Action for U.S. Appl. No. 29/567,476, dated Aug. 10, 2017, 7 pages.
 Response to Non-Final Office Action for U.S. Appl. No. 29/567,207, filed Aug. 29, 2017, 4 pages.
 Notice of Allowance for U.S. Appl. No. 29/567,207, dated Sep. 18, 2017, 9 pages.
 Response to Restriction Requirement for U.S. Appl. No. 29/561,838, filed Sep. 19, 2017, 25 pages.
 Response to Restriction Requirement for U.S. Appl. No. 29/561,794, filed Sep. 20, 2017, 25 pages.
 Notice of Allowance for U.S. Appl. No. 29/561,794, dated Sep. 26, 2017, 5 pages.
 Notice of Allowance for U.S. Appl. No. 29/561,838, dated Sep. 29, 2017, 5 pages.
 Response to Non-Final Office Action for U.S. Appl. No. 29/567,476, filed Oct. 6, 2017, 3 pages.
 Notice of Allowance for U.S. Appl. No. 29/567,476, dated Nov. 1, 2017, 7 pages.

* cited by examiner

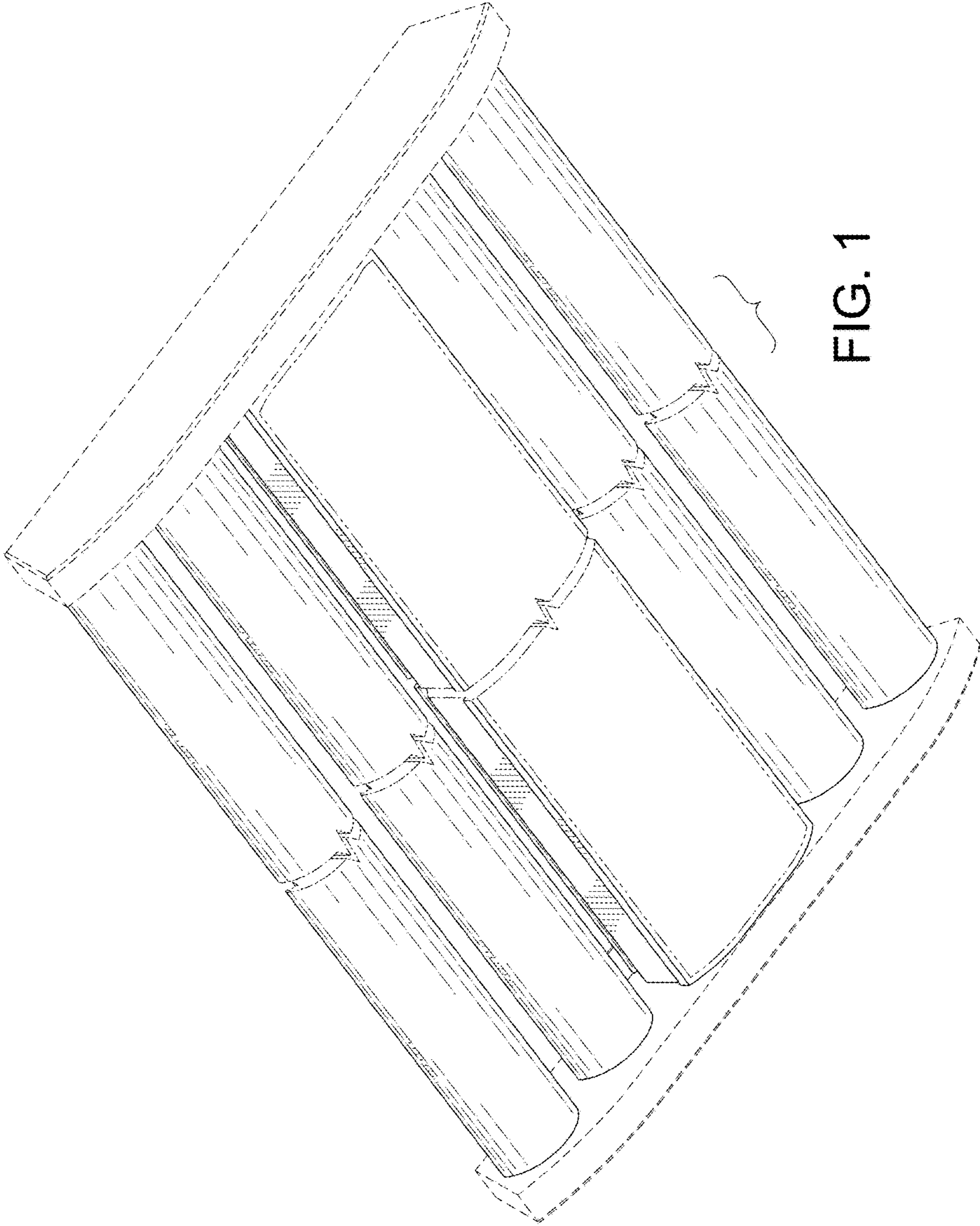

FIG. 1

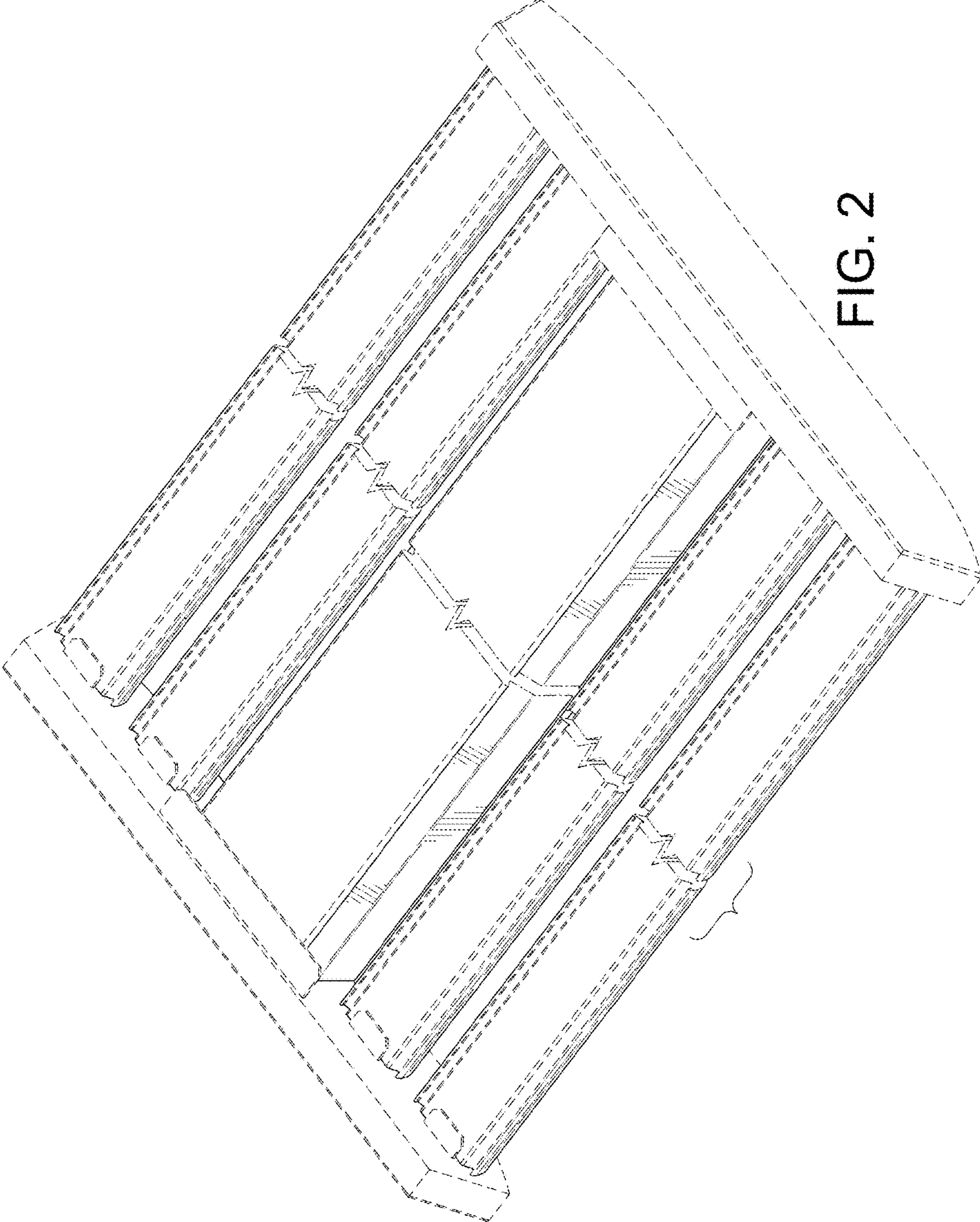

FIG. 2

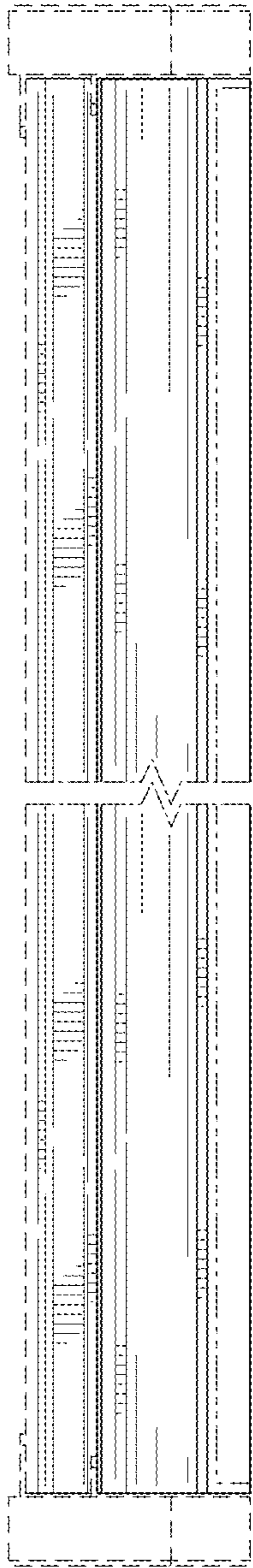

FIG. 3

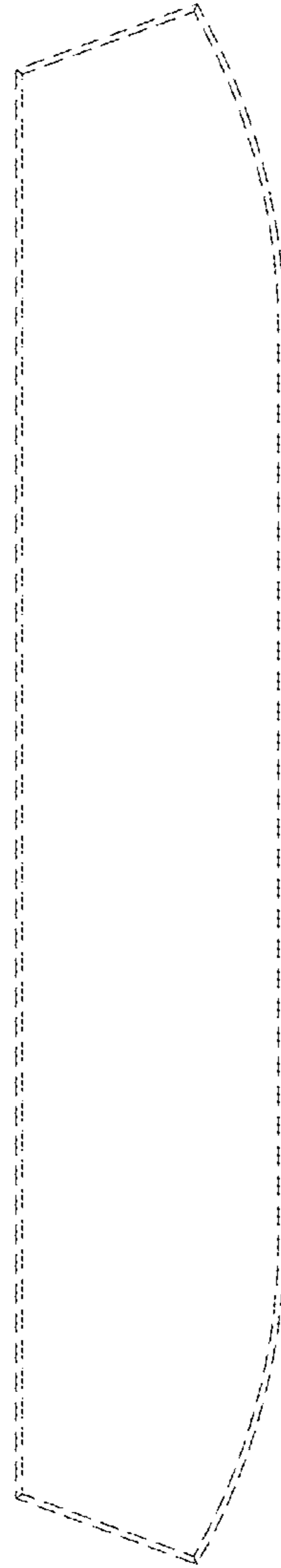

FIG. 4

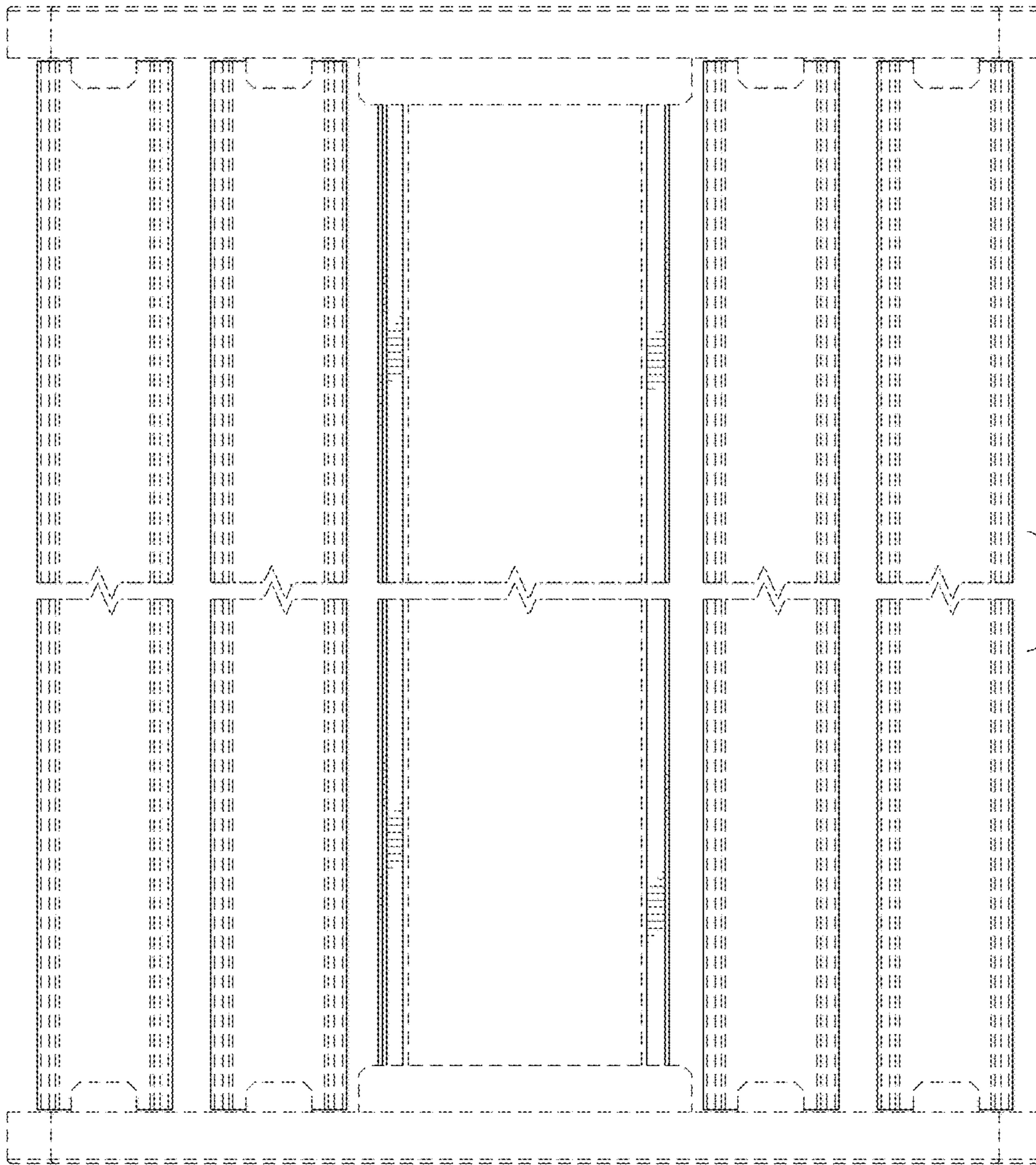

FIG. 5

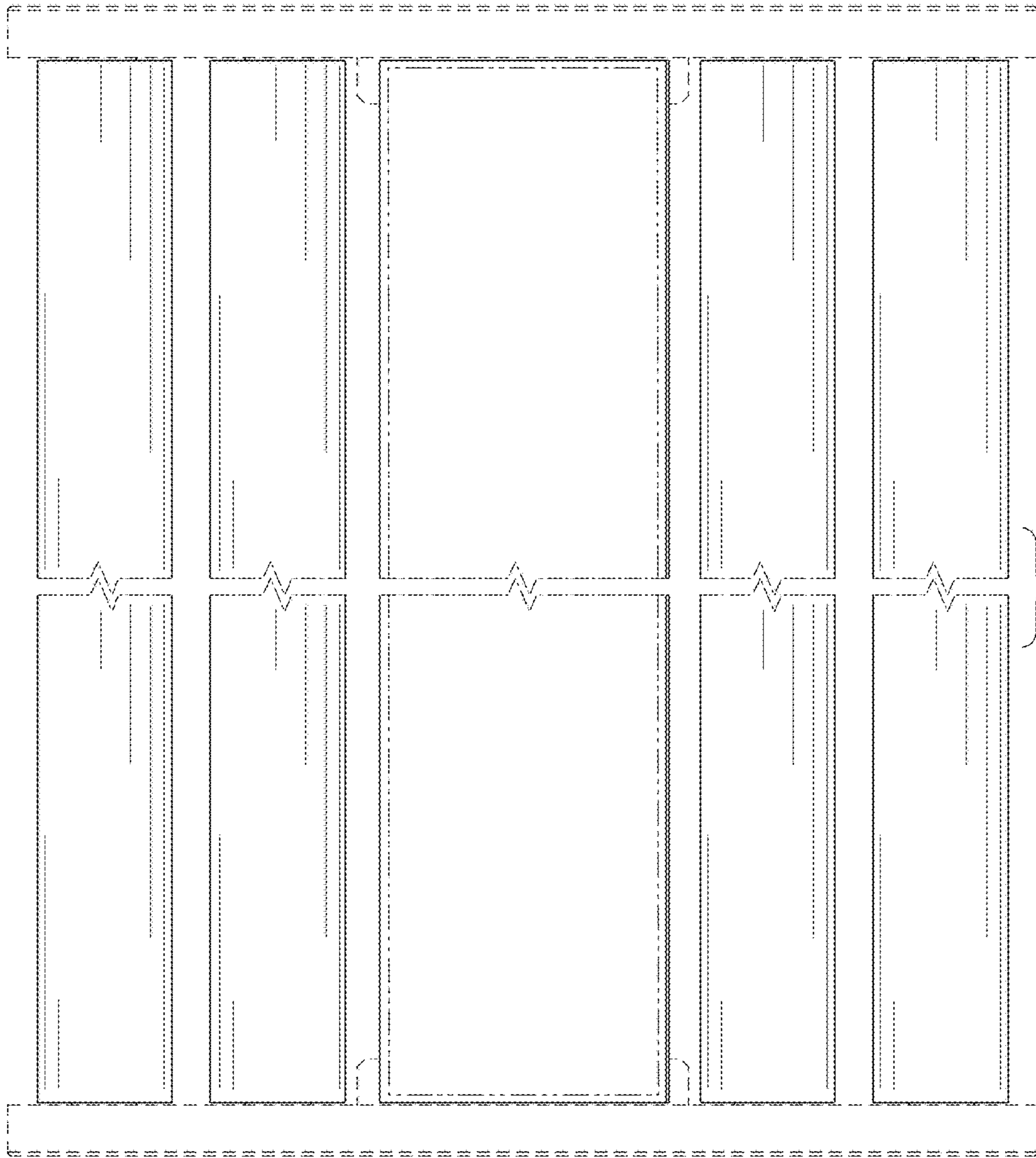

FIG. 6