



US00D822770S

(12) **United States Design Patent** (10) **Patent No.:** **US D822,770 S**
Hsiao et al. (45) **Date of Patent:** **** *Jul. 10, 2018**

(54) **EMOTIVE ROBOTIC CREATURE**

(71) Applicant: **Robert Bosch Start-Up Platform North America LLC, Series 1,** Redwood City, CA (US)

(72) Inventors: **Kaijen Hsiao,** Redwood City, CA (US); **Douglas Dooley,** Redwood City, CA (US); **Sarah Osentoski,** Redwood City, CA (US)

(73) Assignee: **Robert Bosch Start-Up Platform North America, LLC, Series 1,** Redwood City, CA (US)

(*) Notice: This patent is subject to a terminal disclaimer.

(**) Term: **15 Years**

(21) Appl. No.: **29/587,060**

(22) Filed: **Dec. 9, 2016**

(51) **LOC (11) Cl.** **21-01**

(52) **U.S. Cl.**
USPC **D21/578; D15/199**

(58) **Field of Classification Search**
USPC **D7/300, 305, 306-311, 397-400; D10/22, 23, 25, 28; D15/10-13, 22, 199;**
(Continued)

(56) **References Cited**

U.S. PATENT DOCUMENTS

D450,788 S * 11/2001 Kawasaki D21/578
D635,603 S * 4/2011 Paz Rodriguez D15/199
(Continued)

OTHER PUBLICATIONS

Meet Kuri, the Bosch-backed 'bot aiming to crack home robotics, posted on slashgear.com, posted Jan. 3, 2017, no production date given, [online], [site visited Aug. 10, 2017], Available from Internet,

<URL: <https://www.slashgear.com/mayfield-robotics-kuri-bosch-backed-robot-aiming-to-crack-home-robotics-03469453/>>.*

(Continued)

Primary Examiner — Melanie H Tung

Assistant Examiner — Fritzgerald L Butac

(74) *Attorney, Agent, or Firm* — Jeffrey Schox; Diana Lin

(57) **CLAIM**

I claim the ornamental design for a robotic creature, as shown and described.

DESCRIPTION

FIG. 1 is an isometric view, from the top front left, of a first embodiment of the robotic creature.

FIG. 2 is an isometric view, from the bottom back right, of the first embodiment of the robotic creature.

FIG. 3 is a plan view from the top of the first embodiment of the robotic creature.

FIG. 4 is an elevation view from the front of the first embodiment of the robotic creature.

FIG. 5 is an elevation view from the left side of the first embodiment of the robotic creature.

FIG. 6 is an elevation view from the back of the first embodiment of the robotic creature.

FIG. 7 is an elevation view from the right side of the first embodiment of the robotic creature.

FIG. 8 is a plan view from the bottom of the first embodiment of the robotic creature.

FIG. 9 is an isometric view, from the top front left, of a second embodiment of the robotic creature.

FIG. 10 is an isometric view, from the bottom back right, of the second embodiment of the robotic creature.

FIG. 11 is a plan view from the top of the second embodiment of the robotic creature.

FIG. 12 is an elevation view from the front of the second embodiment of the robotic creature.

FIG. 13 is an elevation view from the left side of the second embodiment of the robotic creature.

FIG. 14 is an elevation view from the back of the second embodiment of the robotic creature.

(Continued)

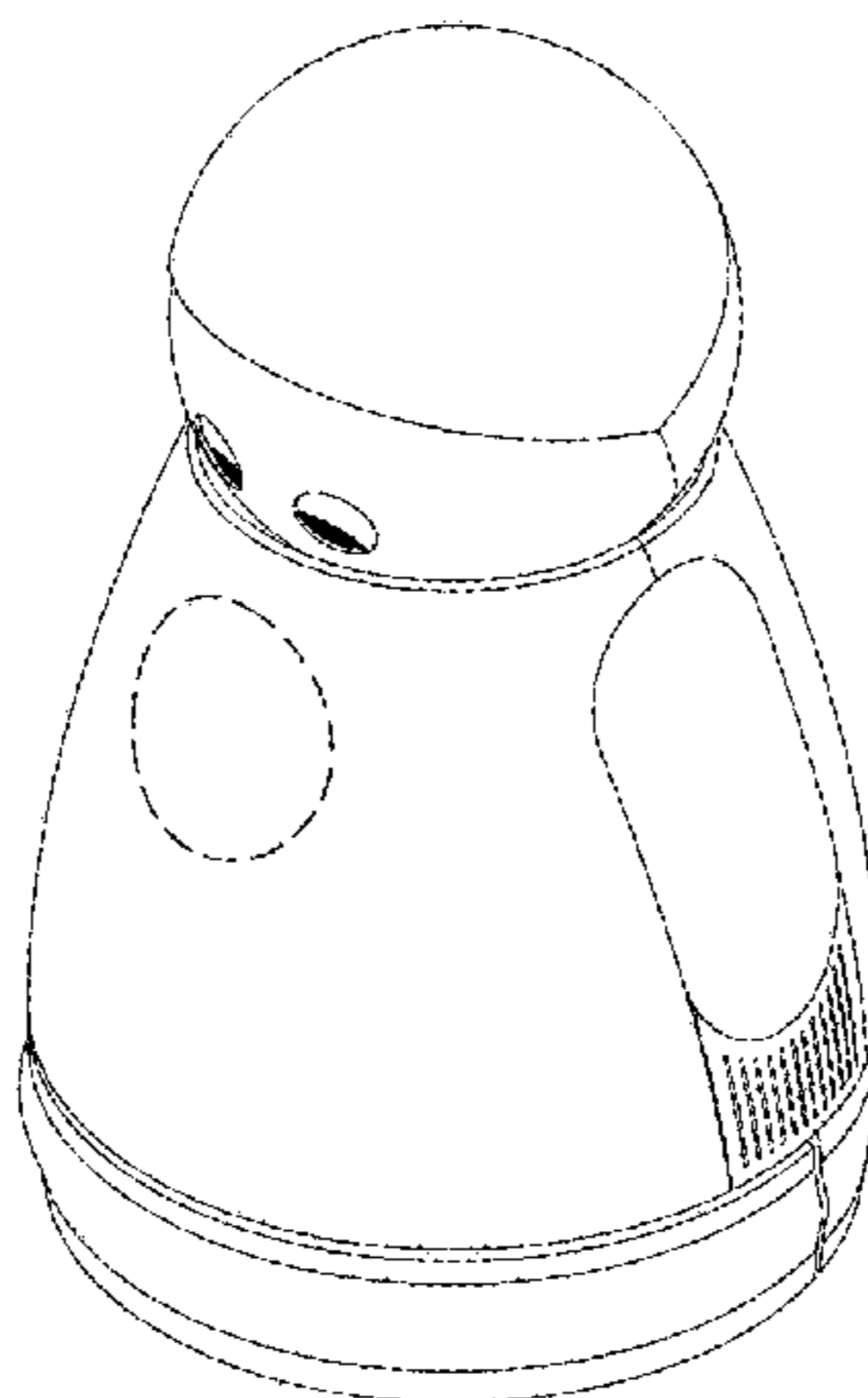

FIG. 15 is an elevation view from the right side of the second embodiment of the robotic creature.

FIG. 16 is a plan view from the bottom of the second embodiment of the robotic creature.

FIG. 17 is an isometric view, from the top front left, of a third embodiment of the robotic creature.

FIG. 18 is an isometric view, from the bottom back right, of the third embodiment of the robotic creature.

FIG. 19 is a plan view from the top of the third embodiment of the robotic creature.

FIG. 20 is an elevation view from the front of the third embodiment of the robotic creature.

FIG. 21 is an elevation view from the left side of the third embodiment of the robotic creature.

FIG. 22 is an elevation view from the back of the third embodiment of the robotic creature.

FIG. 23 is an elevation view from the right side of the third embodiment of the robotic creature; and,

FIG. 24 is a plan view from the bottom of the third embodiment of the robotic creature.

The broken lines show portions of a robotic creature, that form no part of the claimed design.

1 Claim, 9 Drawing Sheets

(58) **Field of Classification Search**

USPC D20/1, 4, 5, 8; D23/383; D32/17, 18, D32/21, 22, 31-34

CPC A63H 11/00; A63H 2200/00; B25J 9/00; B25J 9/04; B25J 18/00; G06N 3/00; G06N 3/004; G06N 3/008

See application file for complete search history.

(56)

References Cited

U.S. PATENT DOCUMENTS

D685,438	S	*	7/2013	Fan	D15/199
D710,953	S	*	8/2014	Katsutani	D15/199
D725,167	S	*	3/2015	Song	D15/199
D746,886	S	*	1/2016	Breazeal	D15/199
D765,180	S	*	8/2016	Huang	D20/5
D766,644	S	*	9/2016	Huang	D15/199
D774,148	S	*	12/2016	Hong	D21/578
D780,271	S	*	2/2017	Liu	D21/630
D781,945	S	*	3/2017	Uno	D15/199

OTHER PUBLICATIONS

Q.bo Series: Q.bo Pro Evo, posted on roboticstoday.com, no posted date given, no production date given, [online], [site visited Aug. 10, 2017], Available from Internet, <URL: <http://www.roboticstoday.com/robots/qbo-pro-evo>>.*

Interview With Maud Verraes From Blue Frog Robotics, posted on crowdassist.co, posted Jan. 9, 2016, no production date given, [online], [site visited Aug. 10, 2017], Available from Internet, <URL: <http://crowdassist.co/interview-with-maud-verraes-from-blue-frog-robotics/>>.*

* cited by examiner

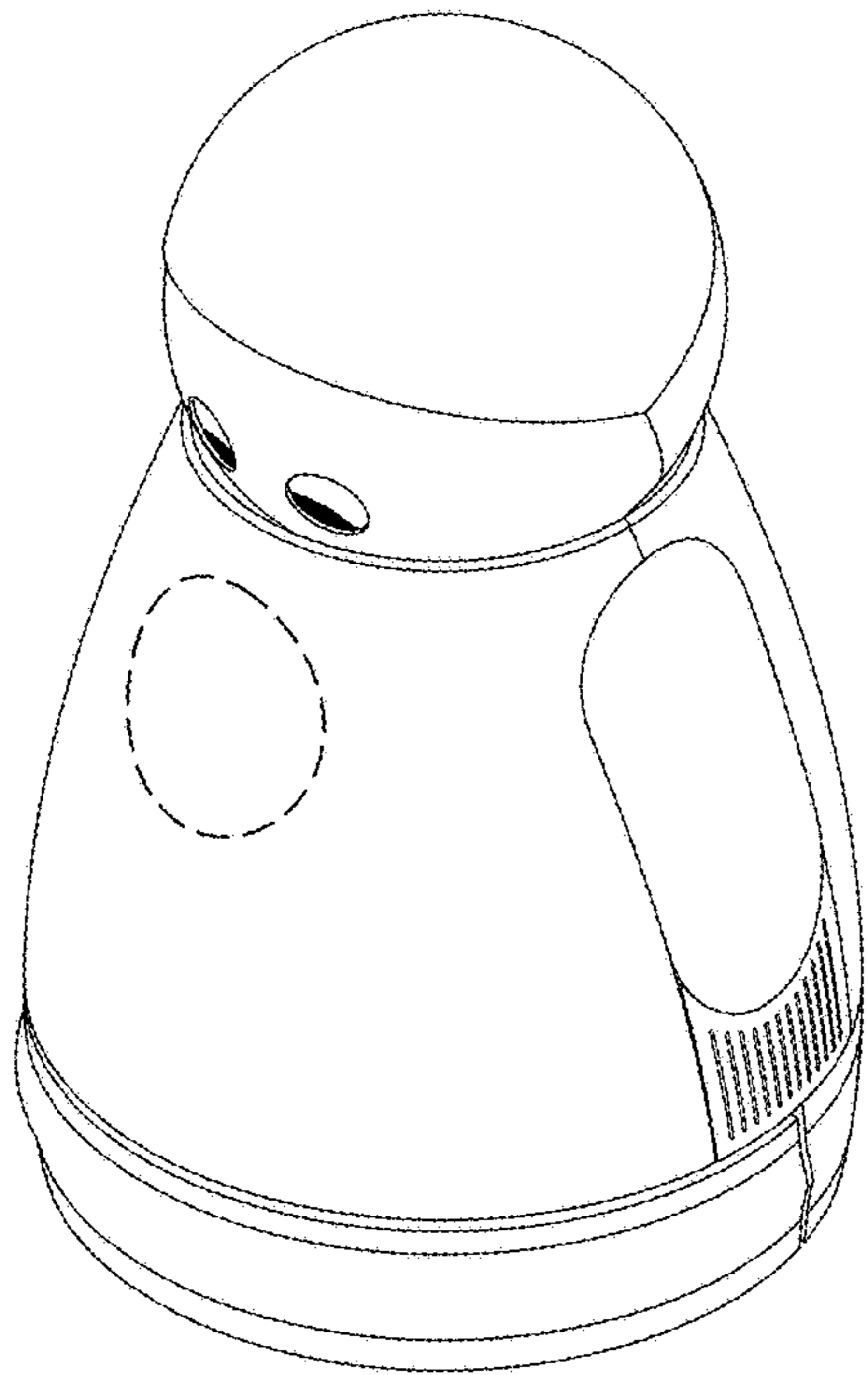

FIG. 1

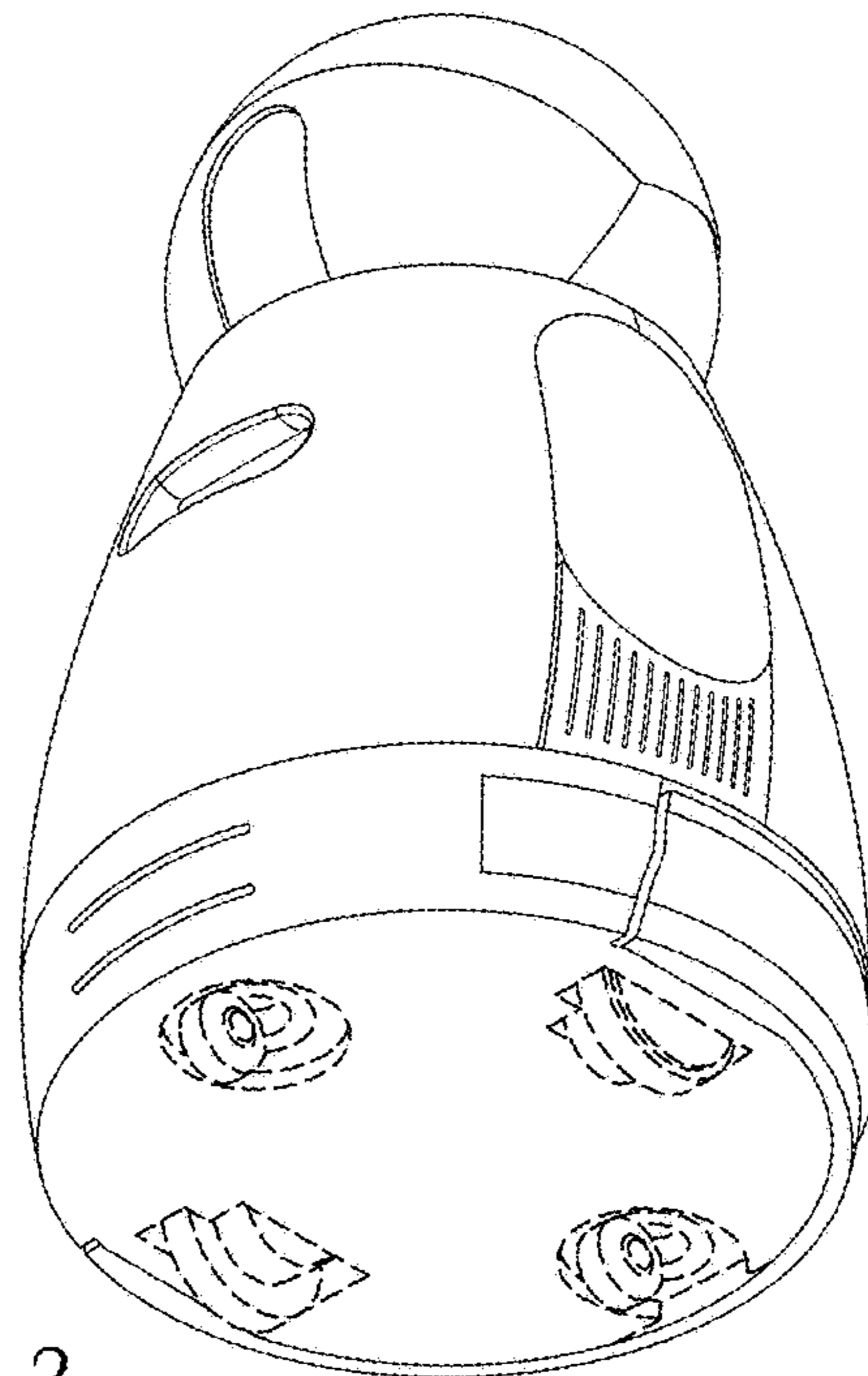

FIG. 2

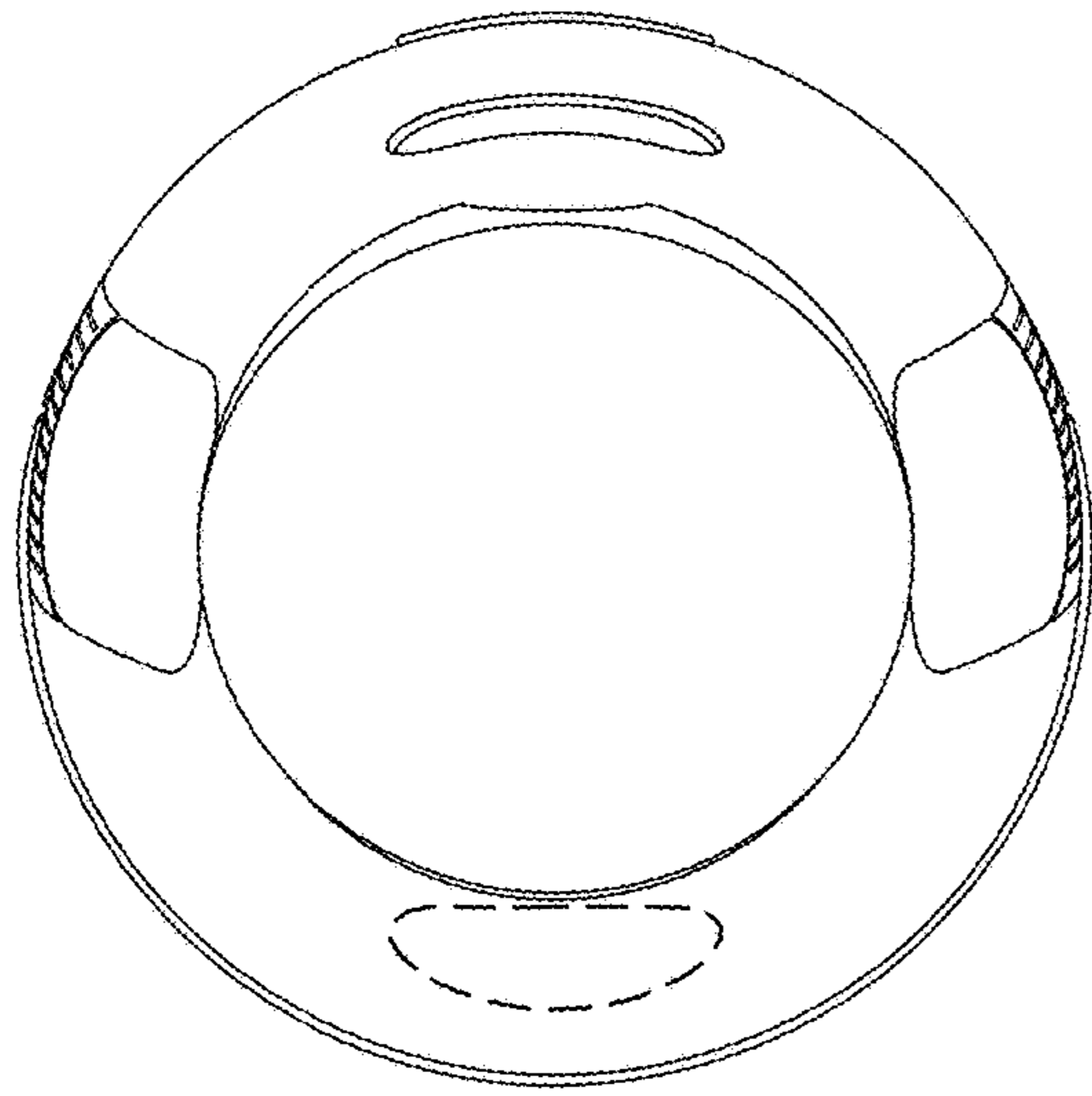

FIG. 3

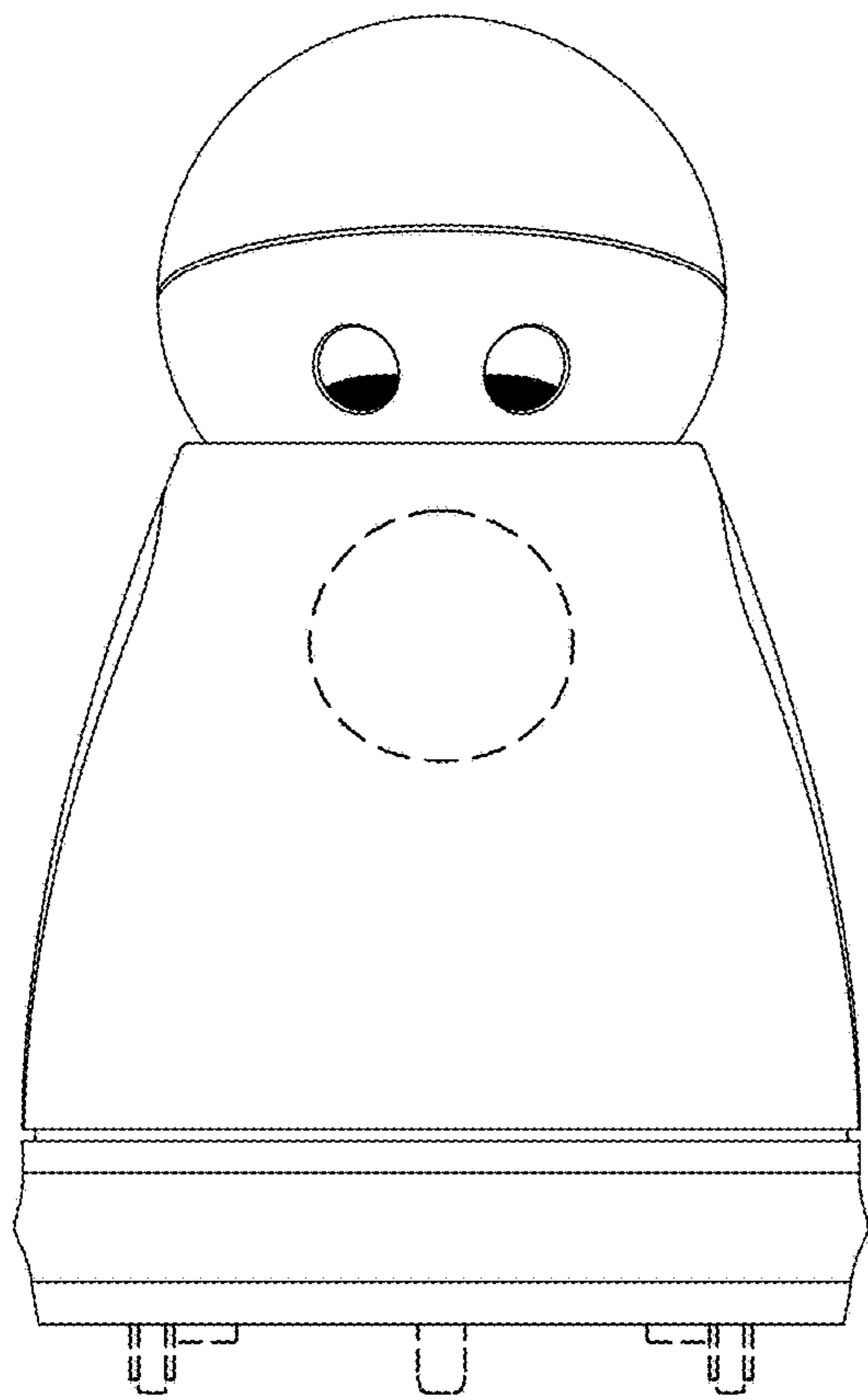

FIG. 4

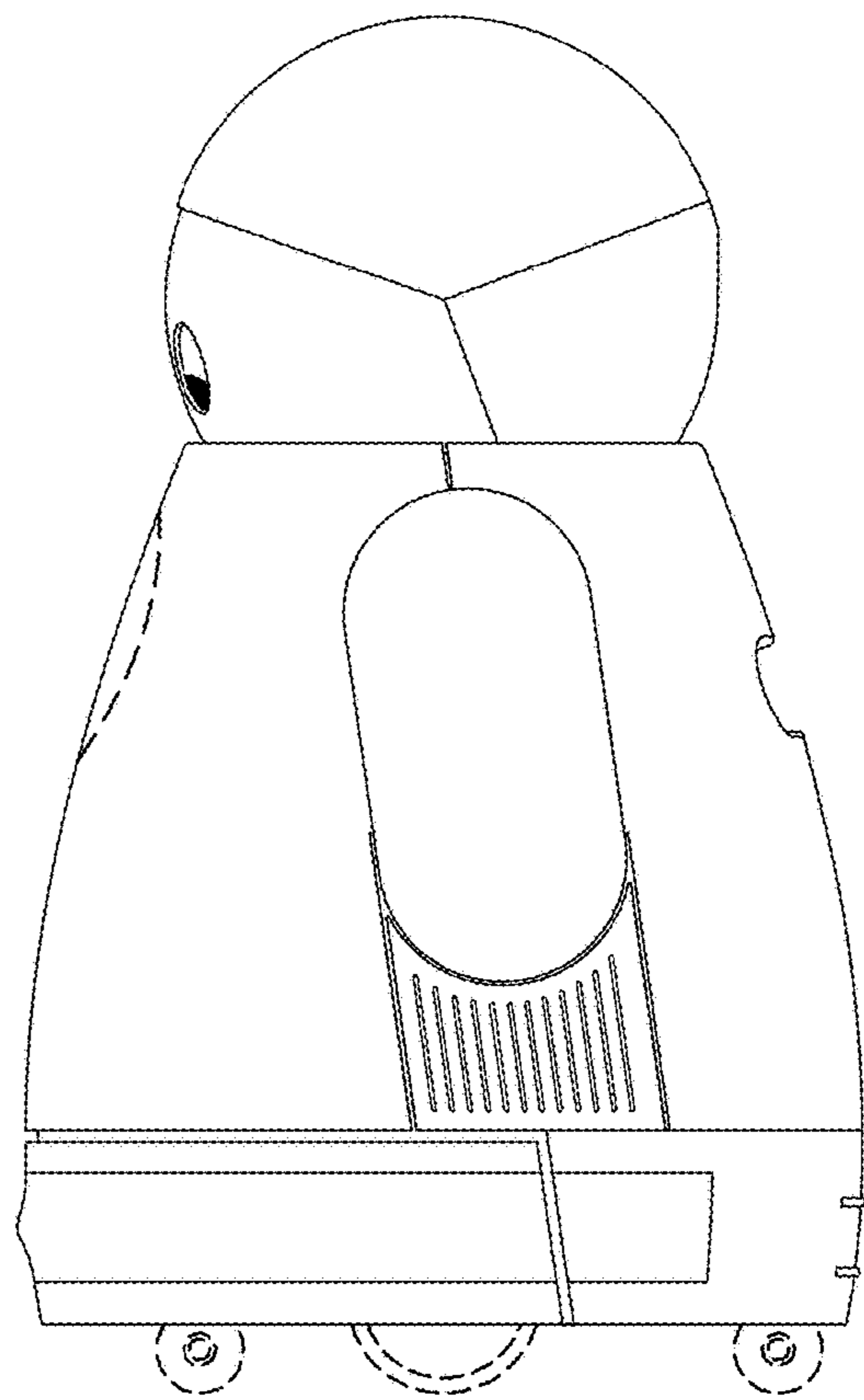

FIG. 5

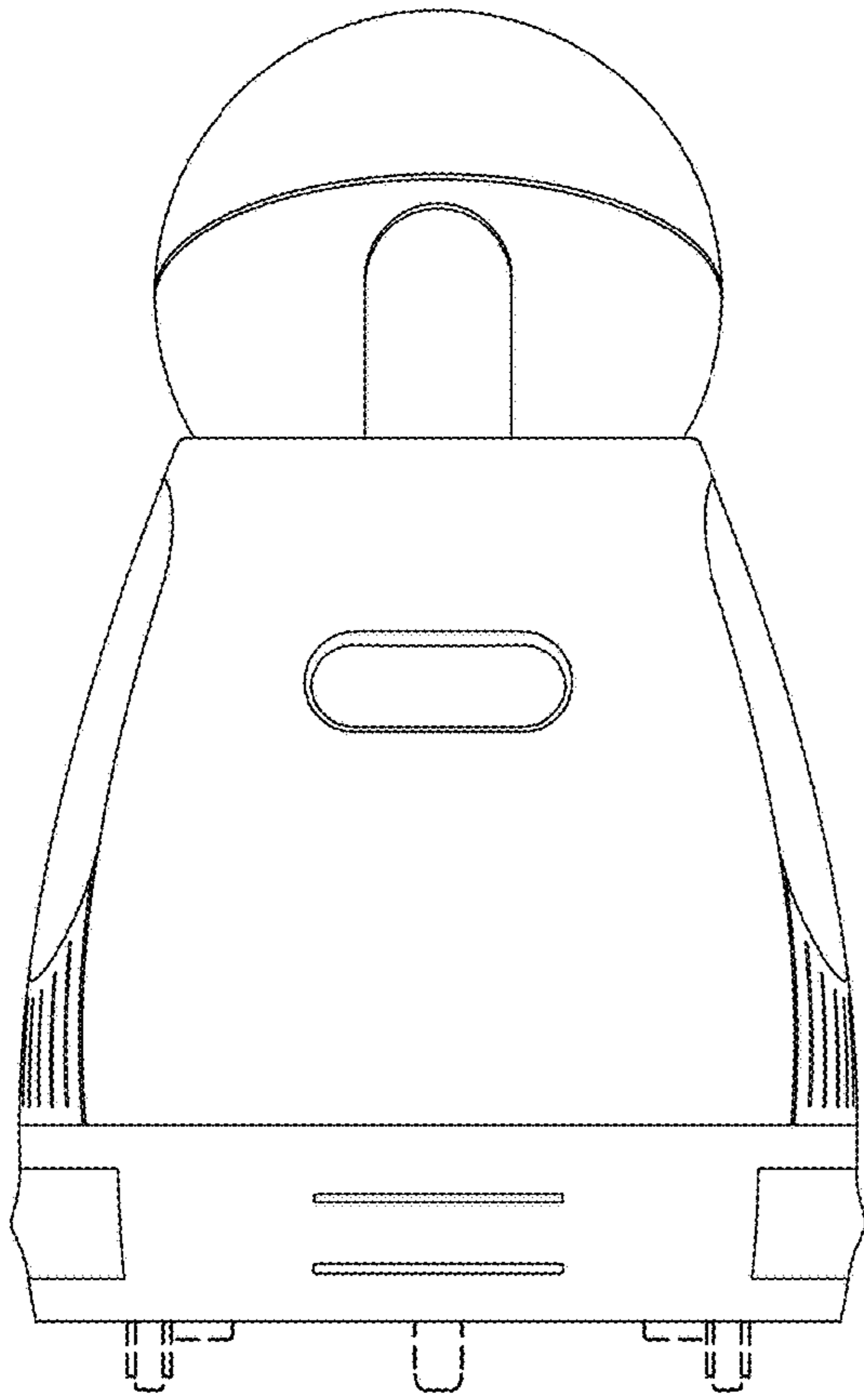

FIG. 6

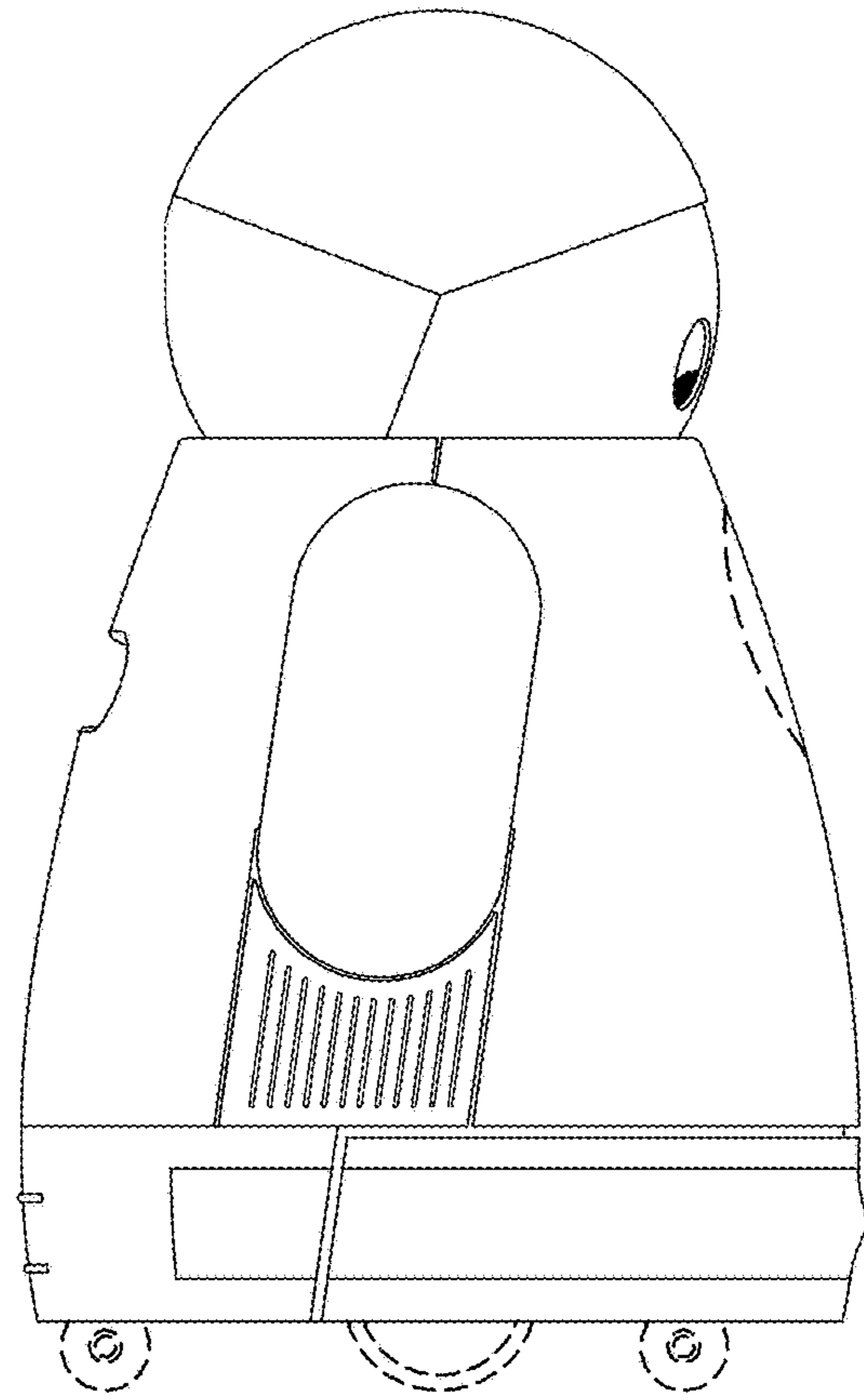

FIG. 7

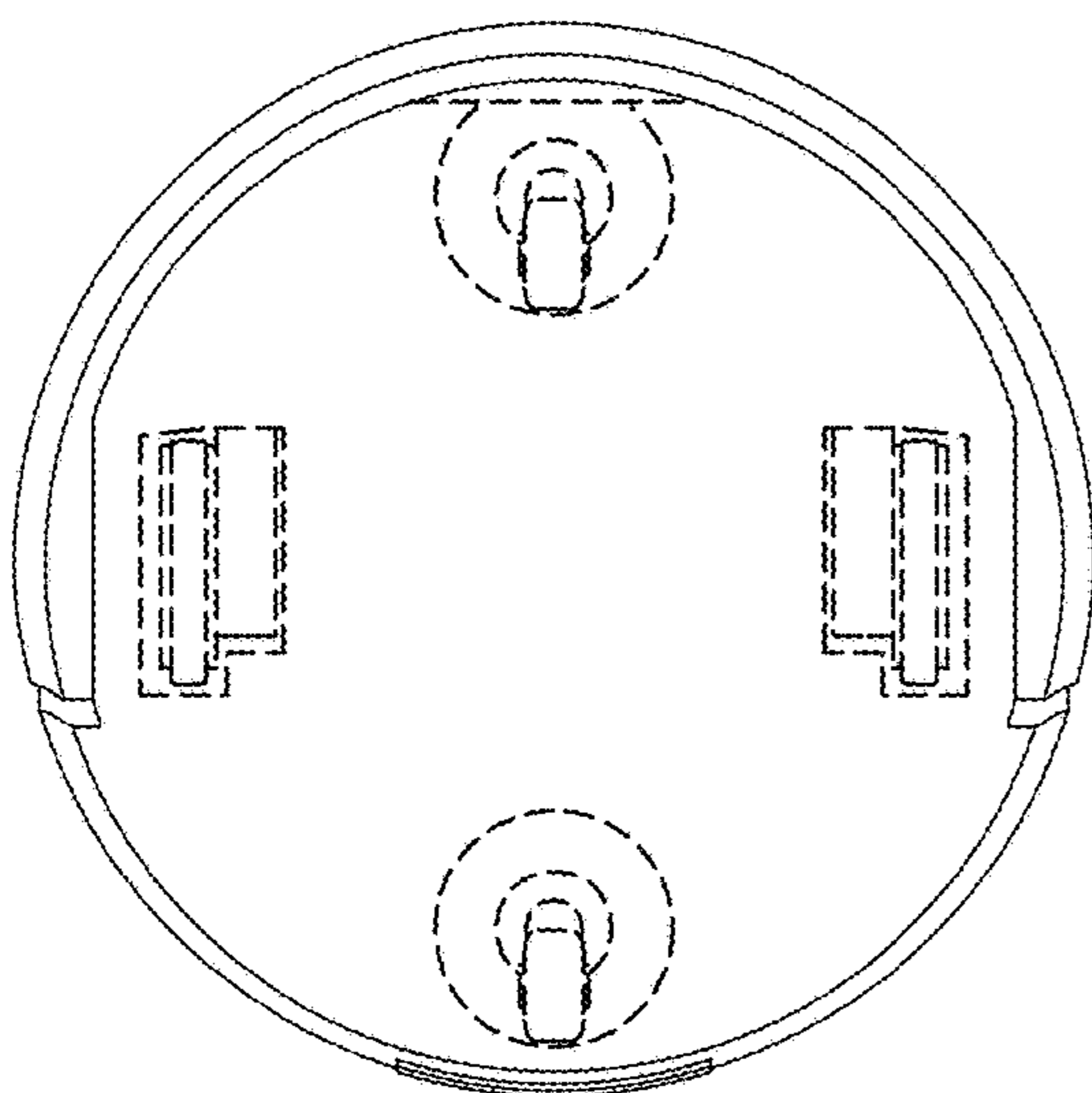

FIG. 8

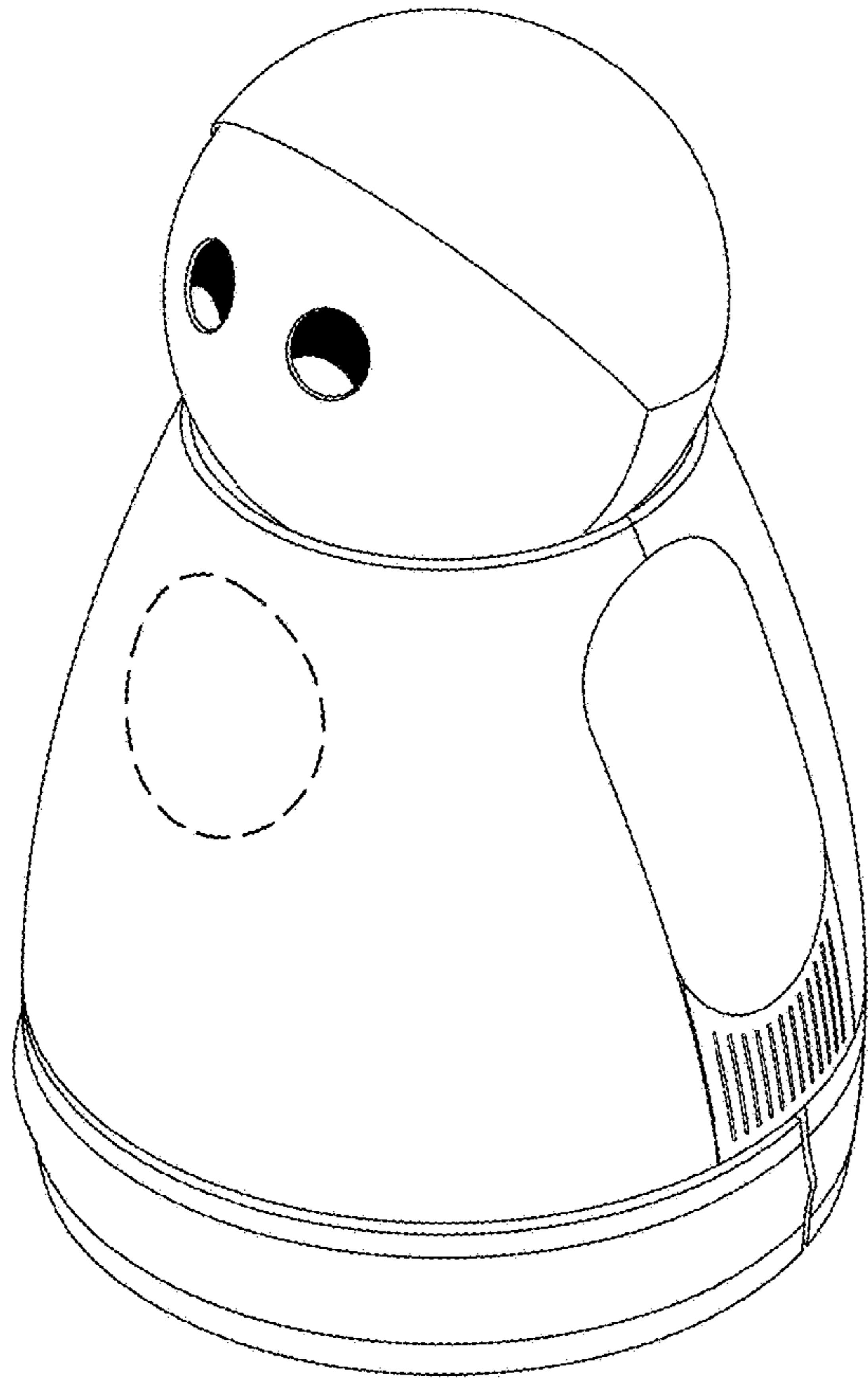

FIG. 9

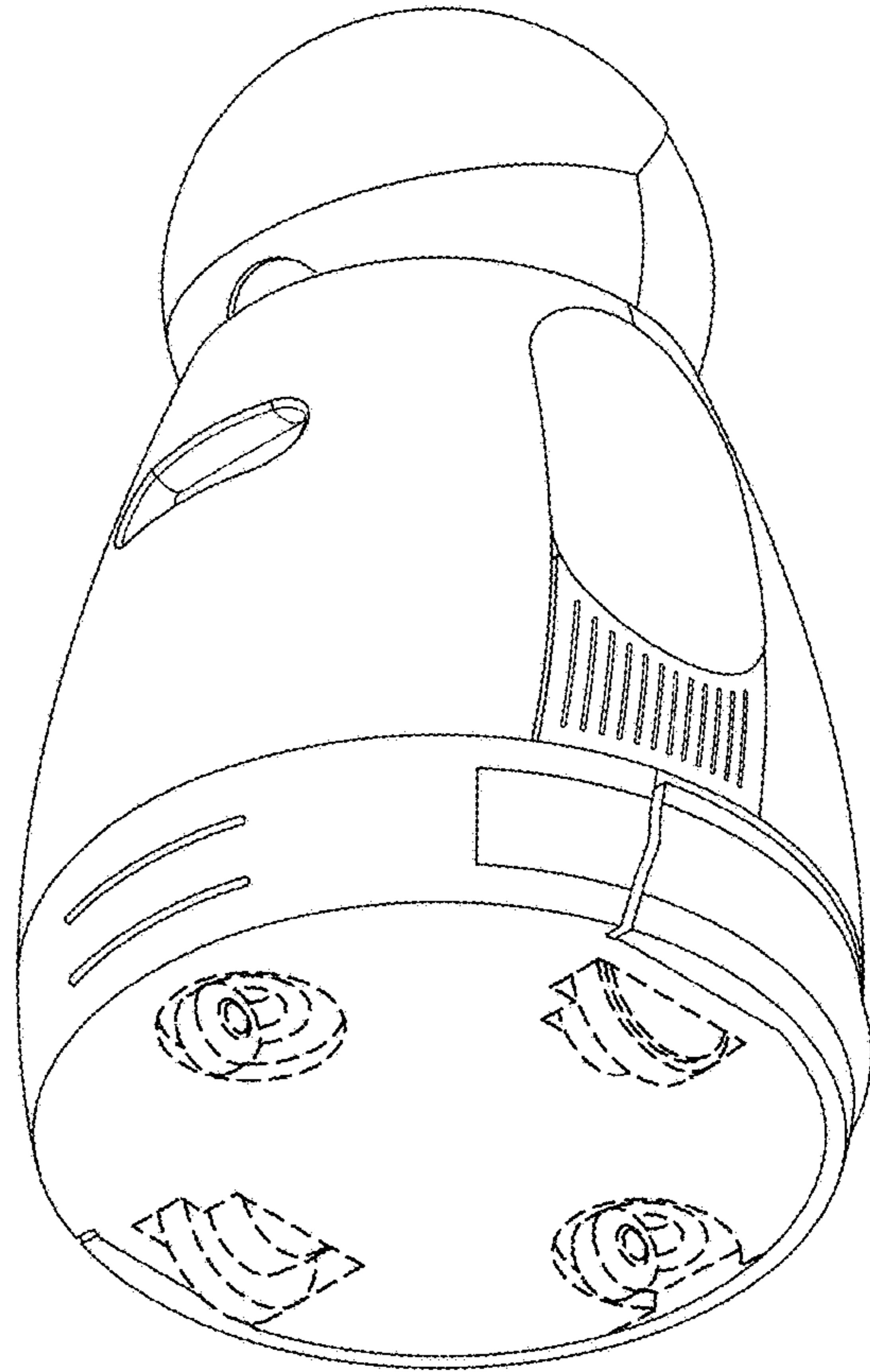

FIG. 10

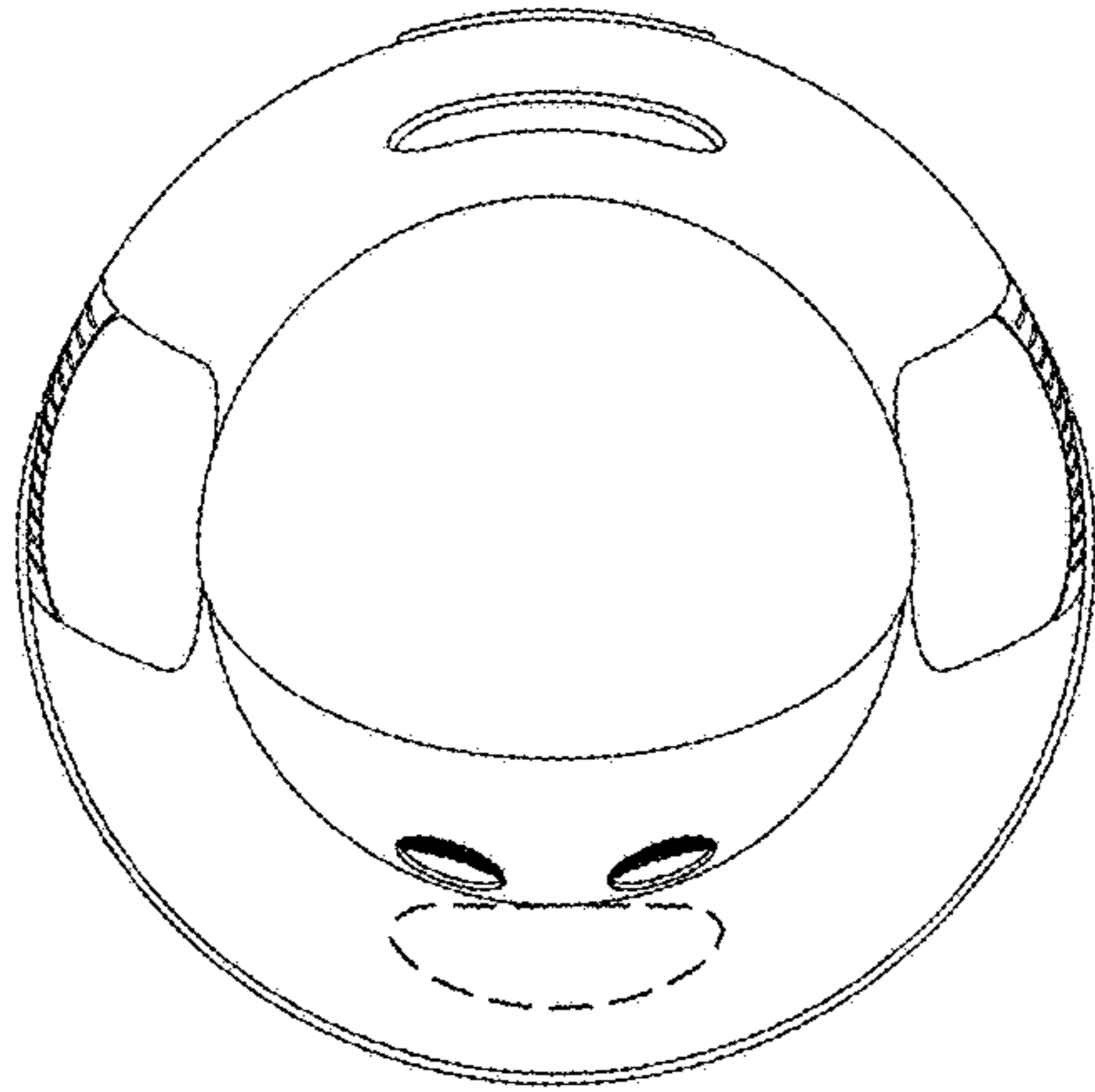

FIG. 11

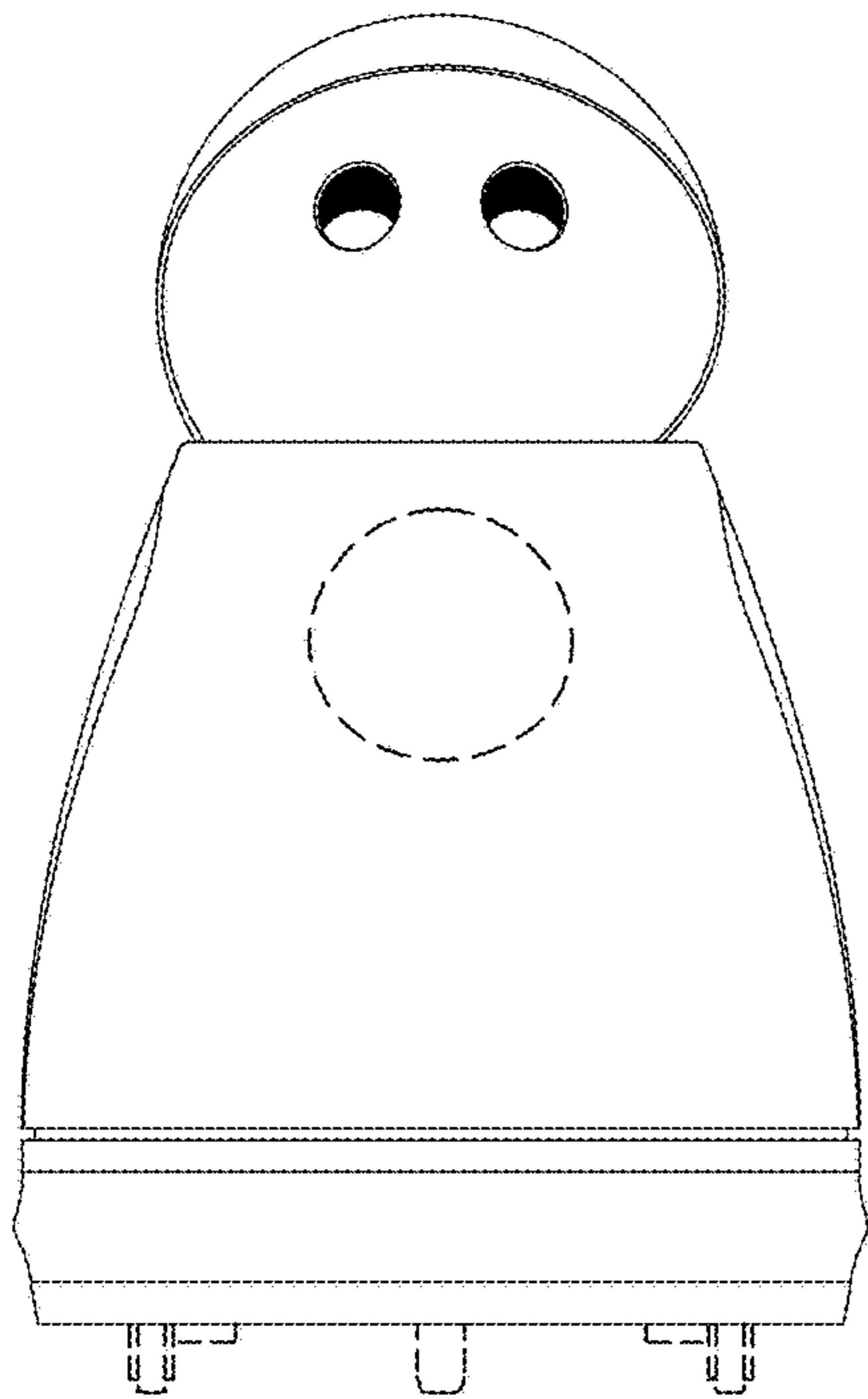

FIG. 12

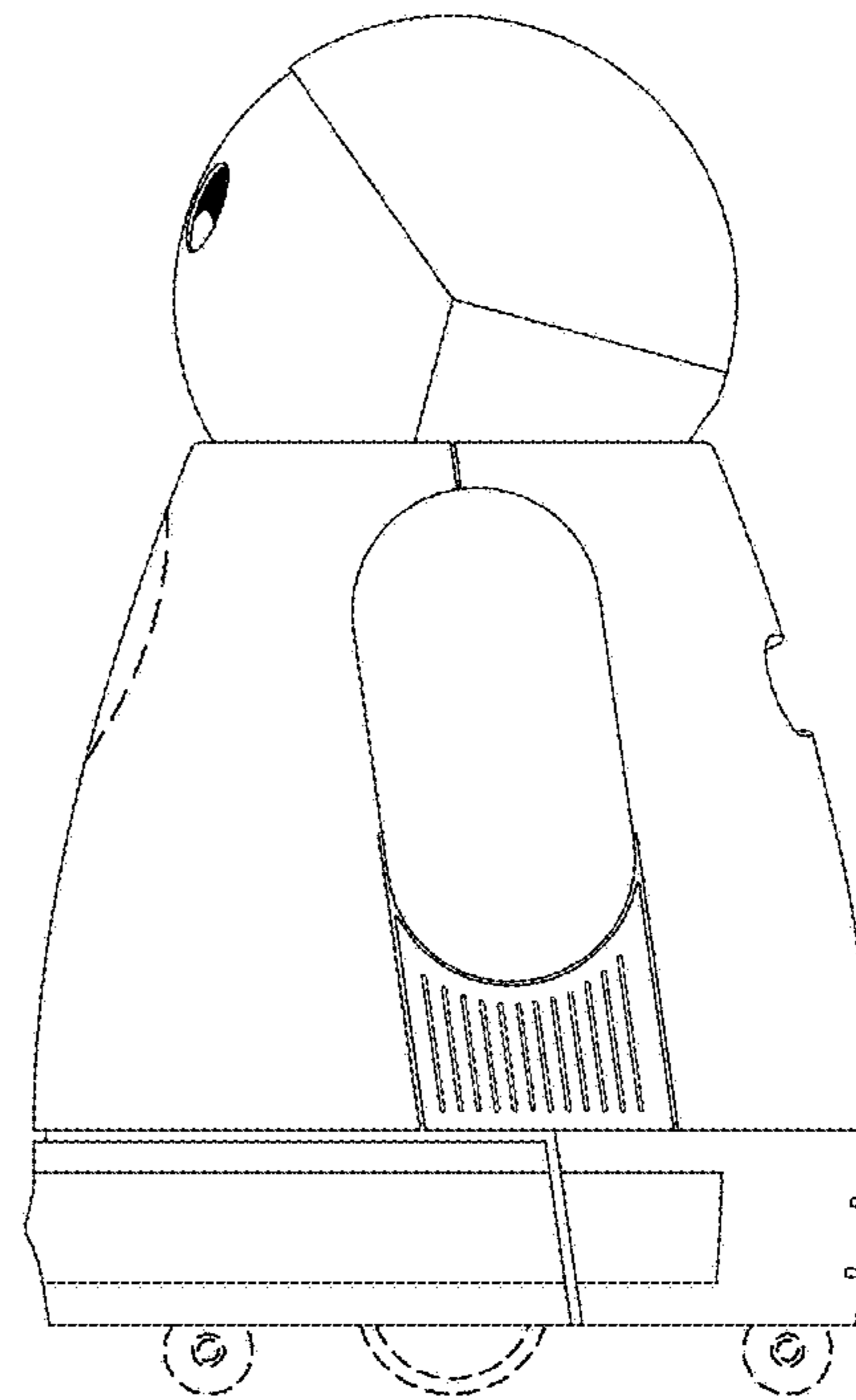

FIG. 13

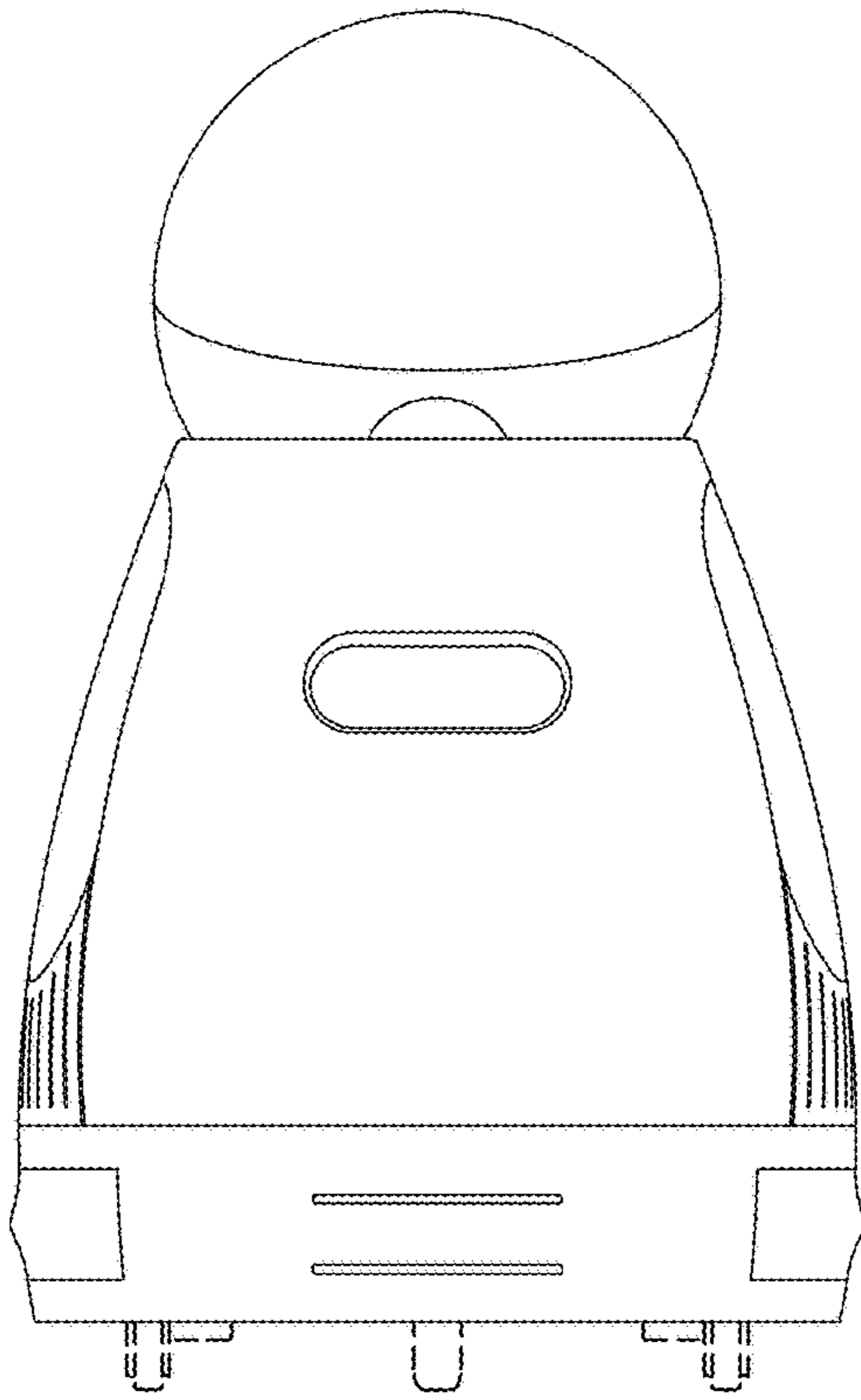

FIG. 14

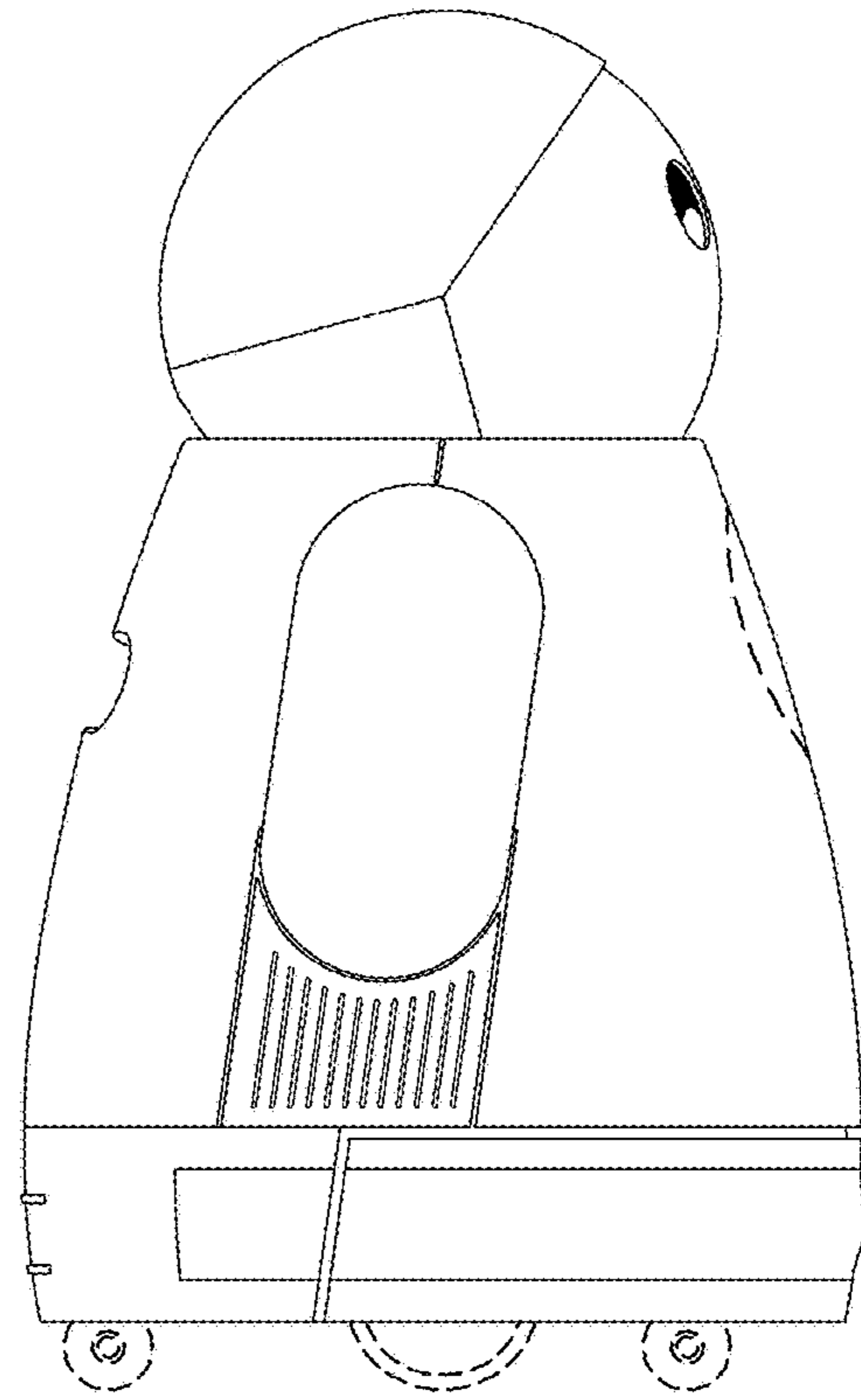

FIG. 15

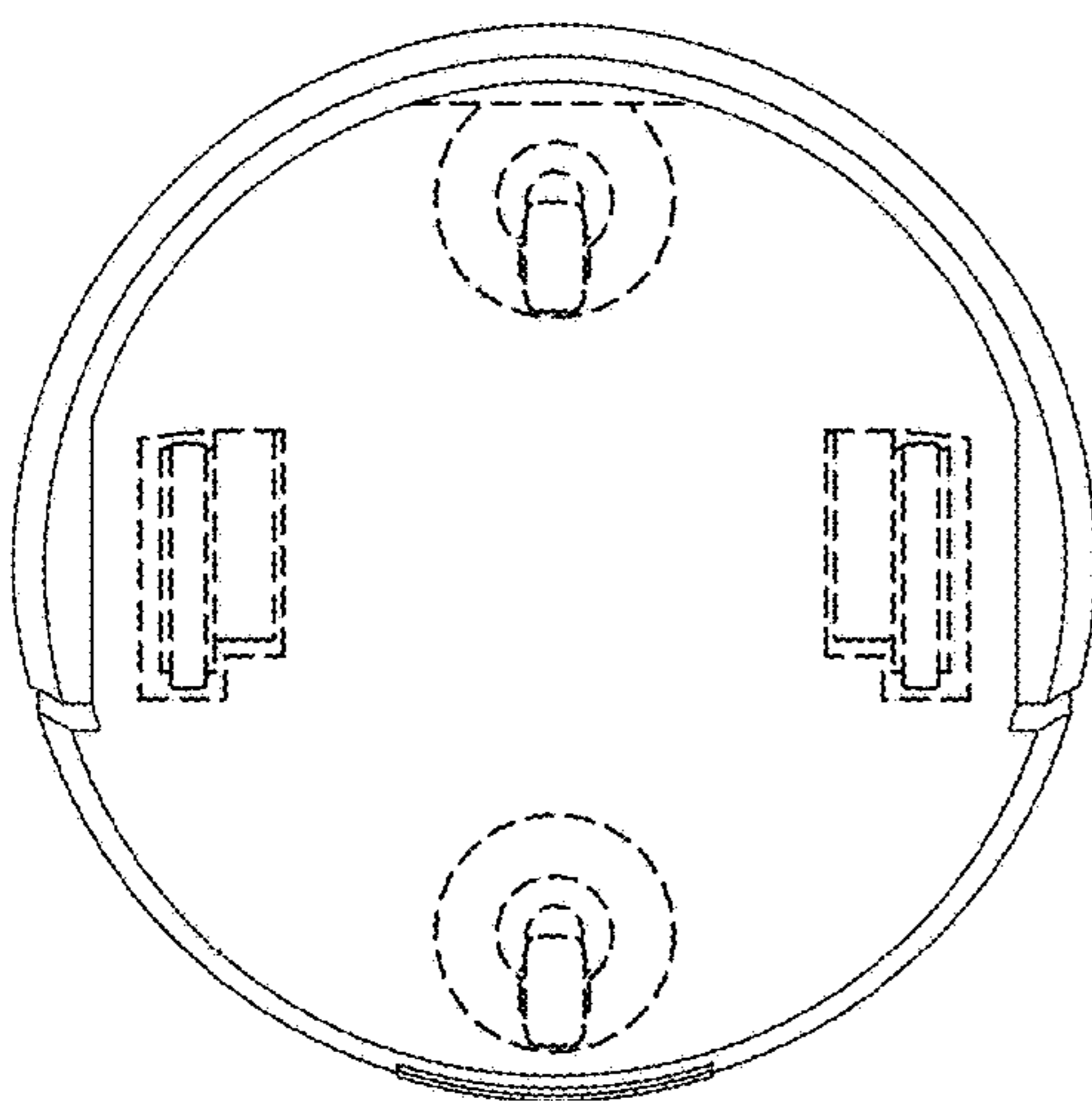

FIG. 16

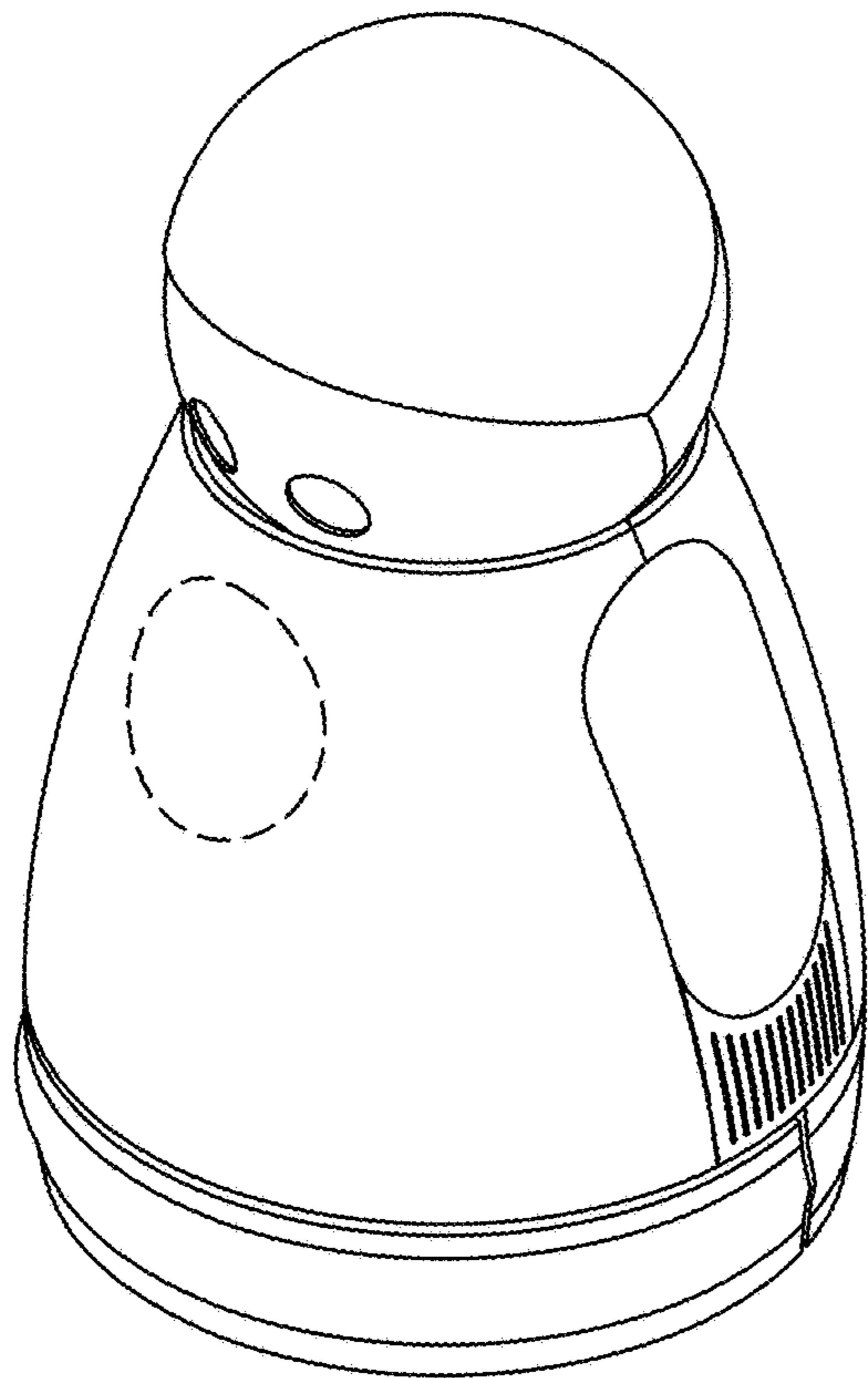

FIG. 17

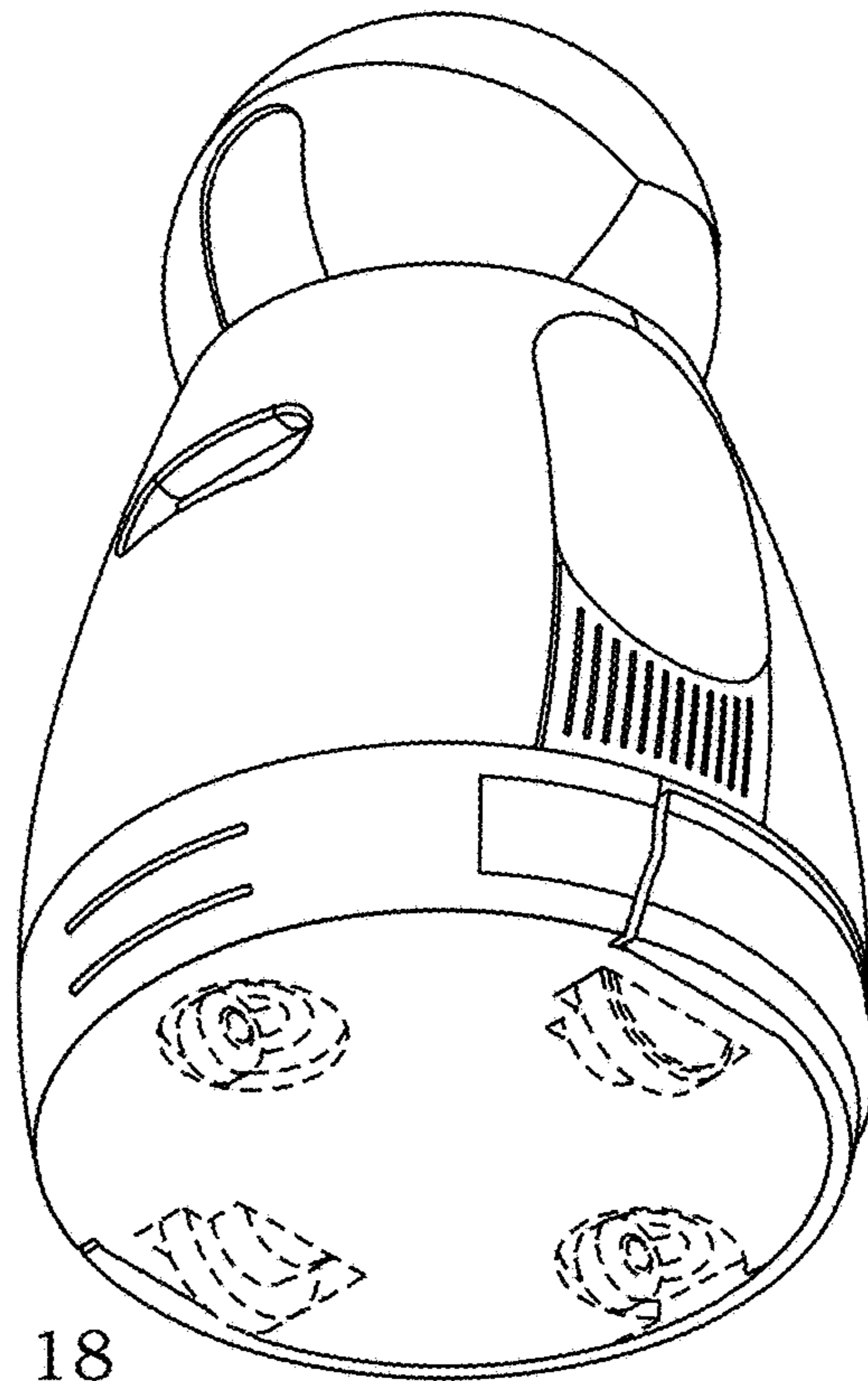

FIG. 18

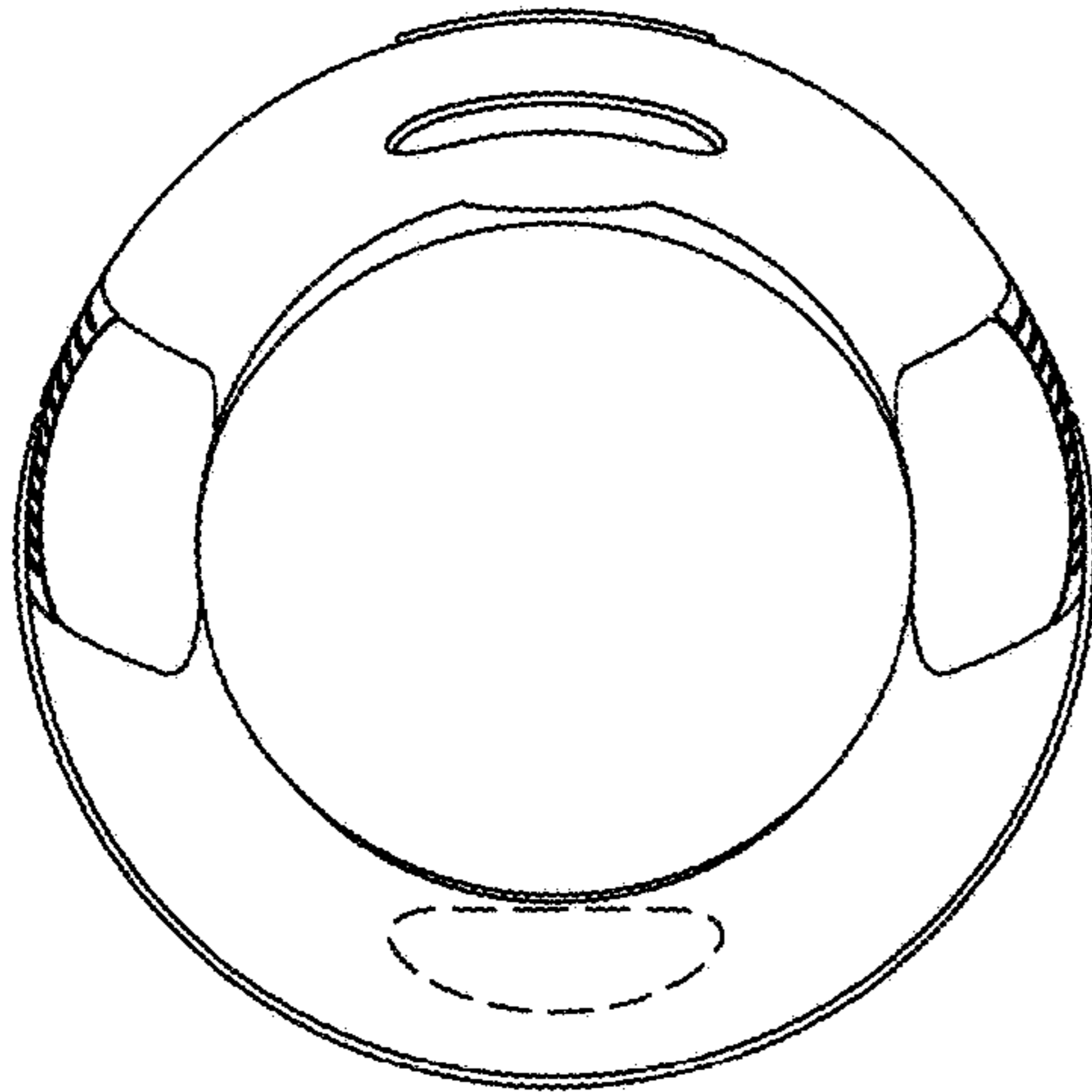

FIG. 19

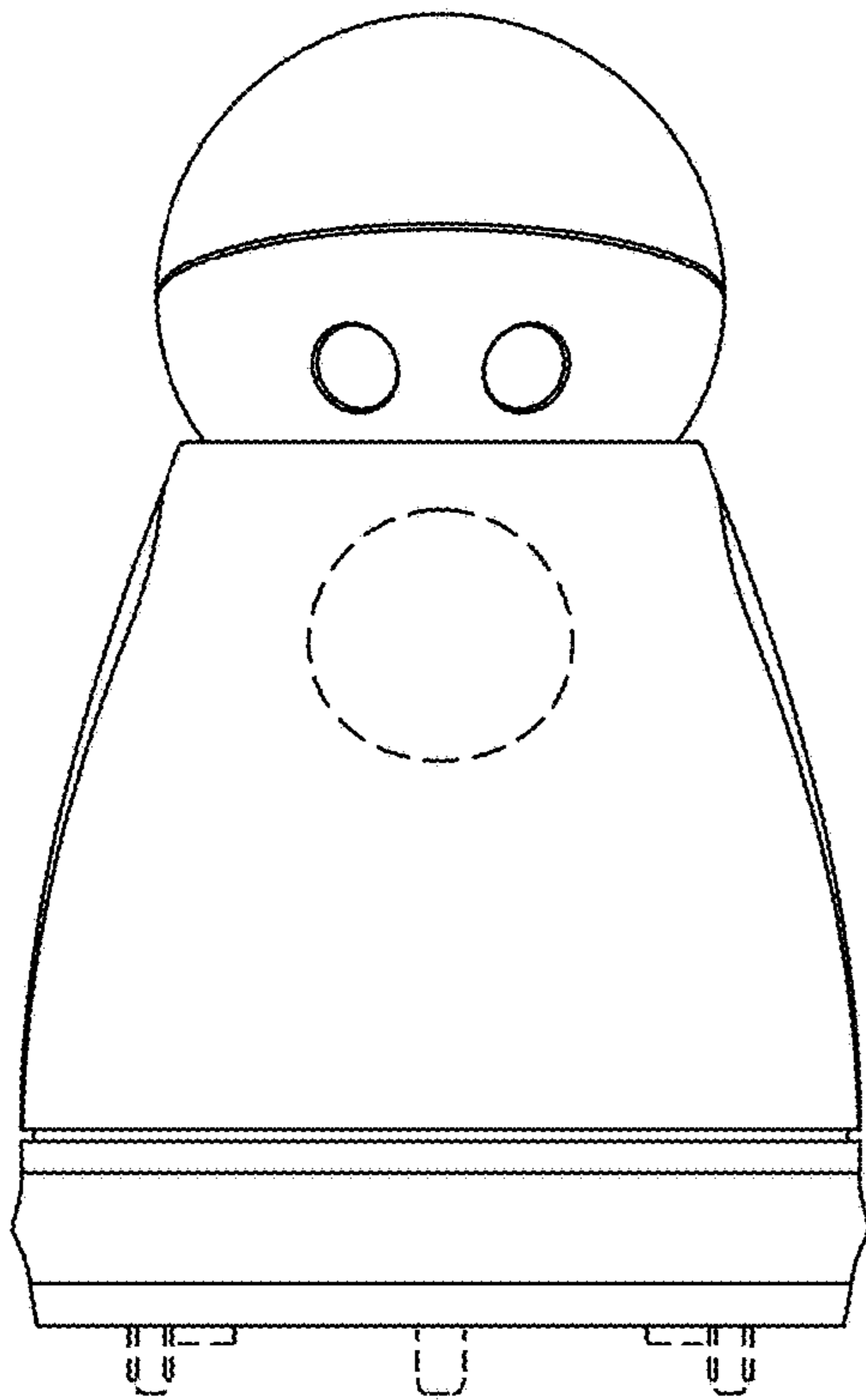

FIG. 20

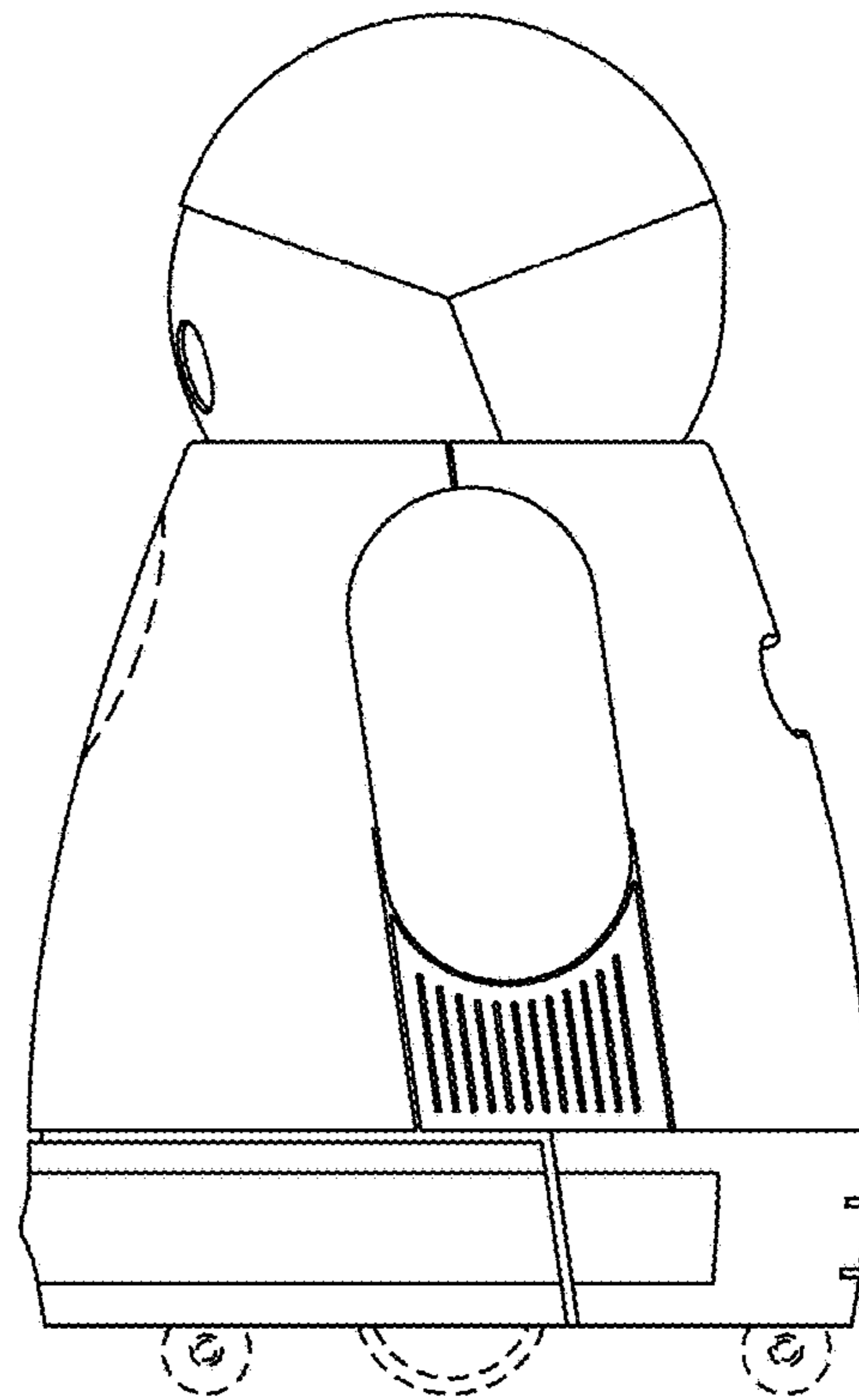

FIG. 21

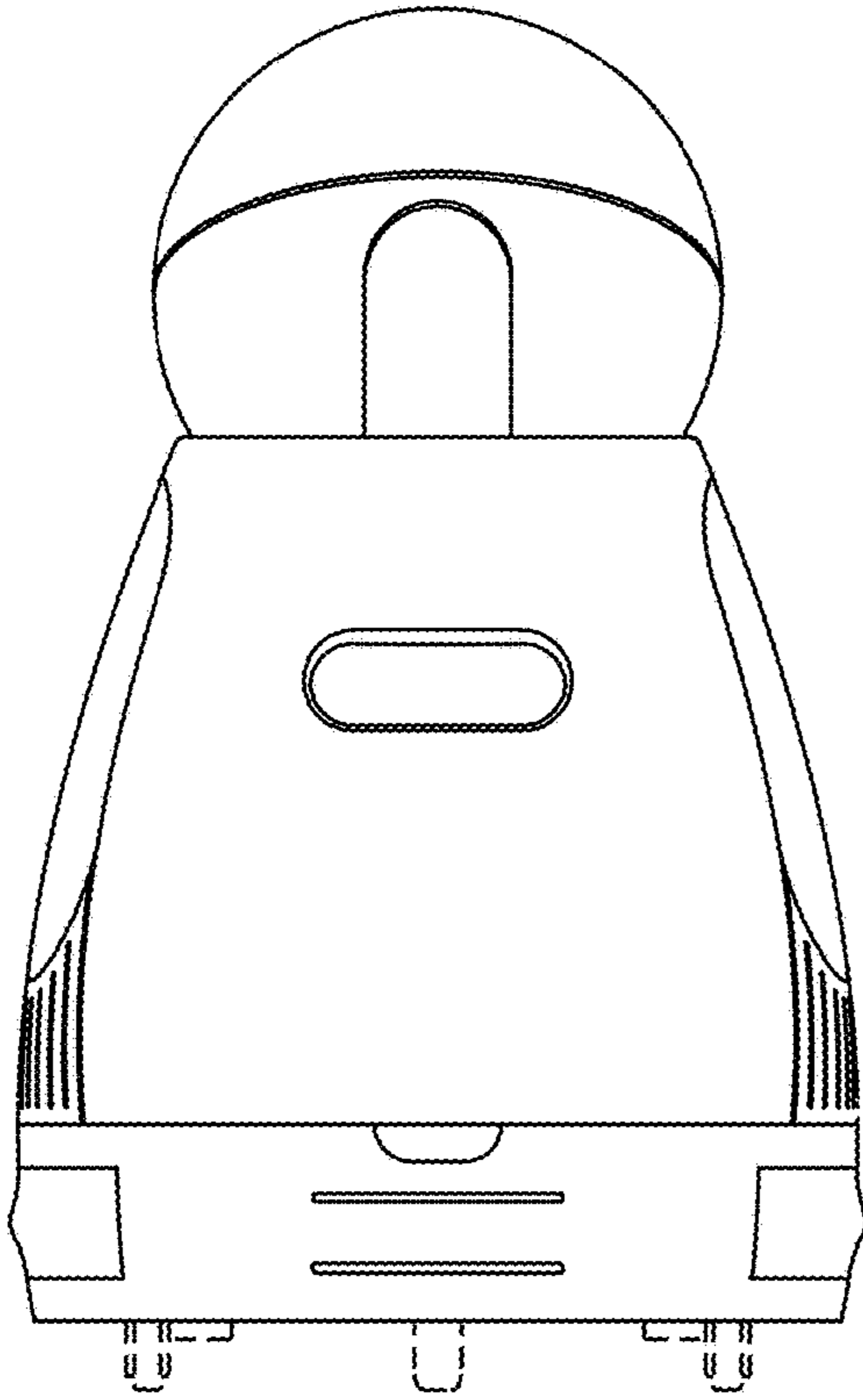

FIG. 22

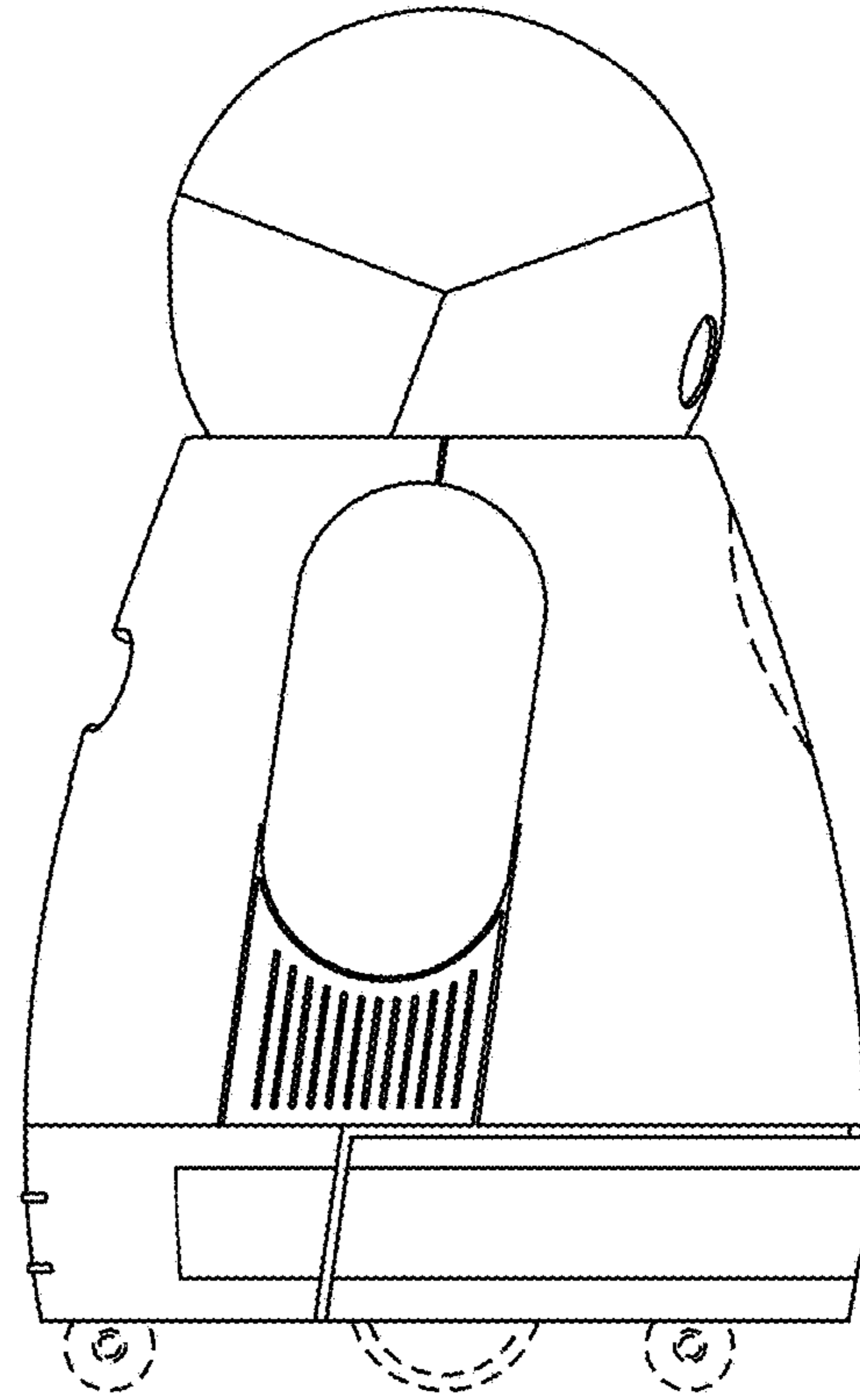

FIG. 23

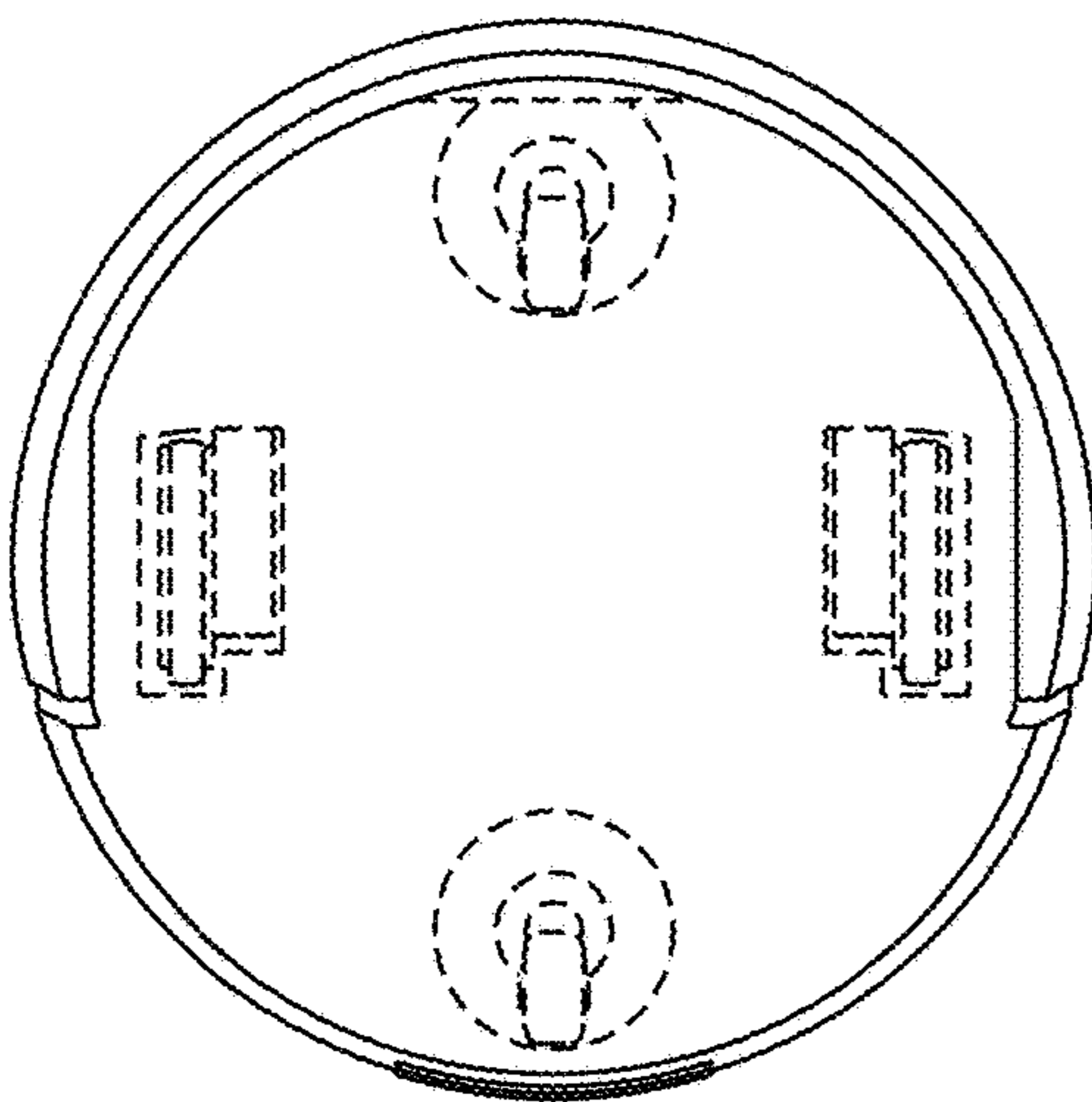

FIG. 24