



US00D822727S

(12) **United States Design Patent**
Matsumoto et al.

(10) **Patent No.:** **US D822,727 S**
(45) **Date of Patent:** **** Jul. 10, 2018**

(54) **ENGAGING MEMBER FOR TOOL CHANGER**

(71) Applicant: **Nitta Corporation**, Osaka-shi (JP)

(72) Inventors: **Ryosuke Matsumoto**, Nabari (JP);
Hiroki Kikuchi, Nabari (JP)

(73) Assignee: **Nitta Corporation**, Osaka-shi (JP)

(**) Term: **15 Years**

(21) Appl. No.: **29/594,607**

(22) Filed: **Feb. 21, 2017**

(30) **Foreign Application Priority Data**

Aug. 26, 2016 (JP) 2016-018183

(51) **LOC (11) Cl.** **15-09**

(52) **U.S. Cl.**
USPC **D15/138; D8/70**

(58) **Field of Classification Search**
USPC D8/70, 71, 354, 394; D15/124, 126, 138
CPC B23Q 3/15513; B25J 15/0425; B25J
15/0466; B25J 15/04
See application file for complete search history.

(56) **References Cited**

U.S. PATENT DOCUMENTS

- 5,044,063 A * 9/1991 Voellmer B23Q 3/15553
294/86.4
- D347,159 S * 5/1994 Crocker, III D8/331
- 5,993,365 A * 11/1999 Stagnitto B25J 15/0491
414/736
- 6,116,966 A * 9/2000 Little B25J 19/0025
439/700
- 6,491,612 B1 * 12/2002 Kurup B23K 9/20
285/268
- 6,533,594 B1 * 3/2003 Kurup B23K 11/362
439/191
- D547,637 S * 7/2007 Blacker D8/354

- D548,571 S * 8/2007 Bigelow D8/349
- D564,343 S * 3/2008 Zakowski D8/363
- D685,623 S * 7/2013 Lewis D8/331
- D741,690 S * 10/2015 Collins, IV D8/354
- D747,780 S * 1/2016 Swan D22/110
- D765,156 S * 8/2016 Matsumoto D15/138
- D765,157 S * 8/2016 Matsumoto D15/138
- D765,158 S * 8/2016 Taniguchi D15/138
- D801,164 S * 10/2017 Powers D8/394
- D801,797 S * 11/2017 Powers D8/394
- 2014/0256527 A1 * 9/2014 Liu B23Q 3/15706
483/54
- 2016/0279806 A1 * 9/2016 Kikuchi B25J 15/0425
- 2016/0294092 A1 * 10/2016 Kikuchi H01R 13/2492
- 2017/0355049 A1 * 12/2017 Matsumoto B25J 15/0425

* cited by examiner

Primary Examiner — Darlington Ly

(74) *Attorney, Agent, or Firm* — Locke Lord LLP

(57) **CLAIM**

The ornamental design for an engaging member for tool changer, as shown and described.

DESCRIPTION

FIG. 1 is a front perspective view of an engaging member for tool changer showing our new design; FIG. 2 is front elevation view thereof; FIG. 3 is a rear elevation view thereof; FIG. 4 is a top plan view thereof; FIG. 5 is a bottom plan view thereof; FIG. 6 is a right side elevation view thereof, to which the left side elevation view is a mirror image; and, FIG. 7 is a cross-sectional view thereof taken along line 7-7 in FIG. 2.

The broken lines in the drawings illustrate portions of the engaging member for tool changer that form no part of the claimed design.

1 Claim, 7 Drawing Sheets

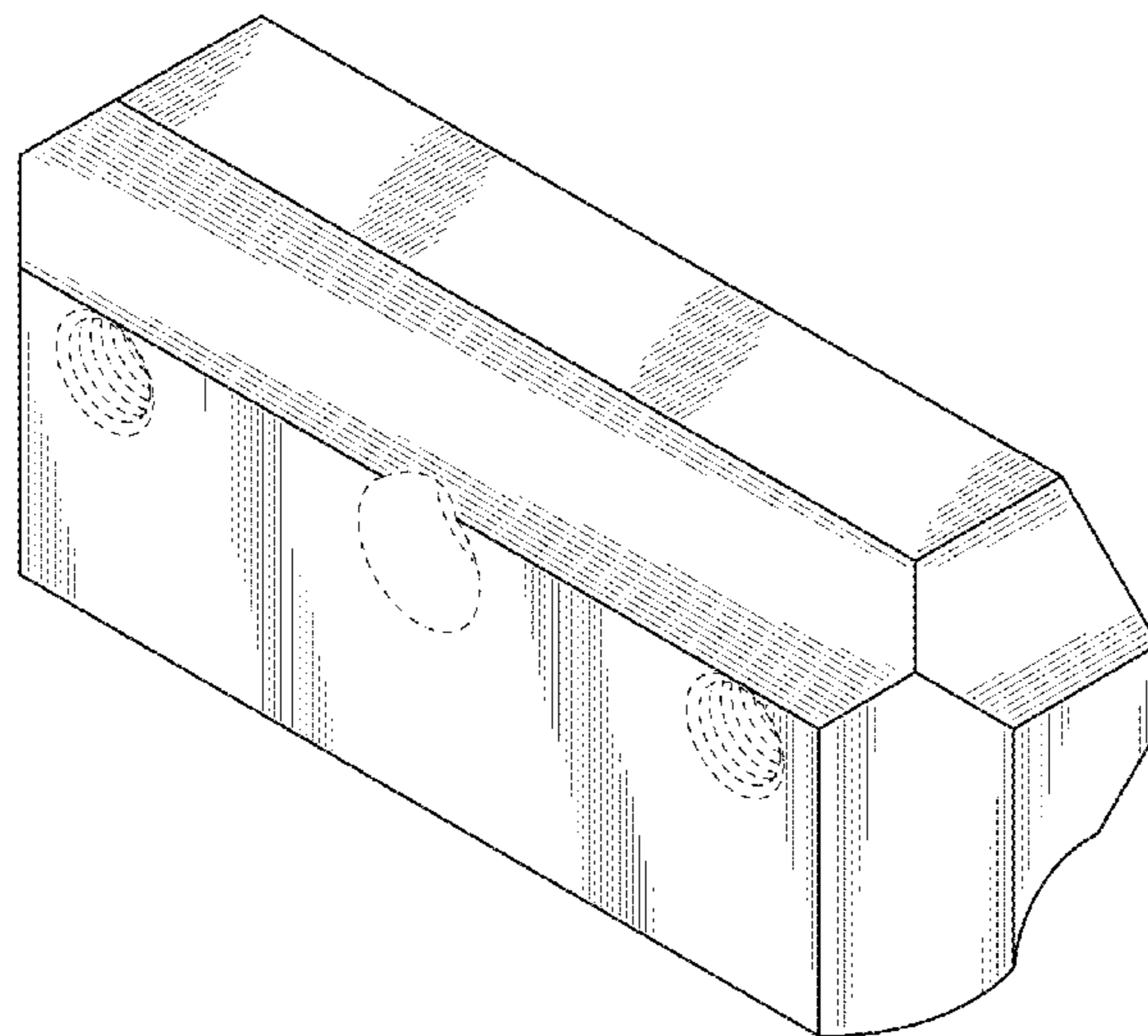

FIG. 1

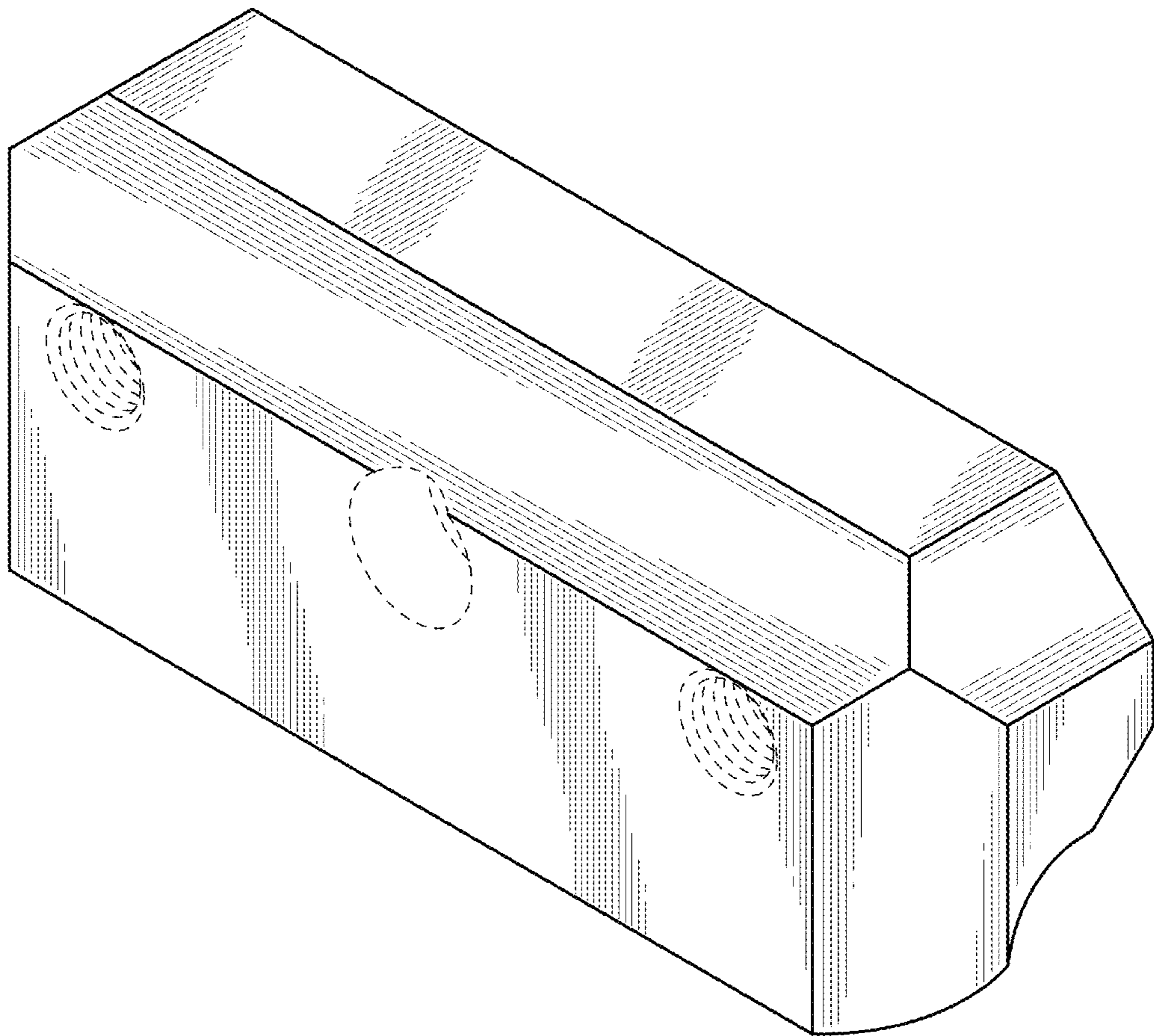

FIG. 2

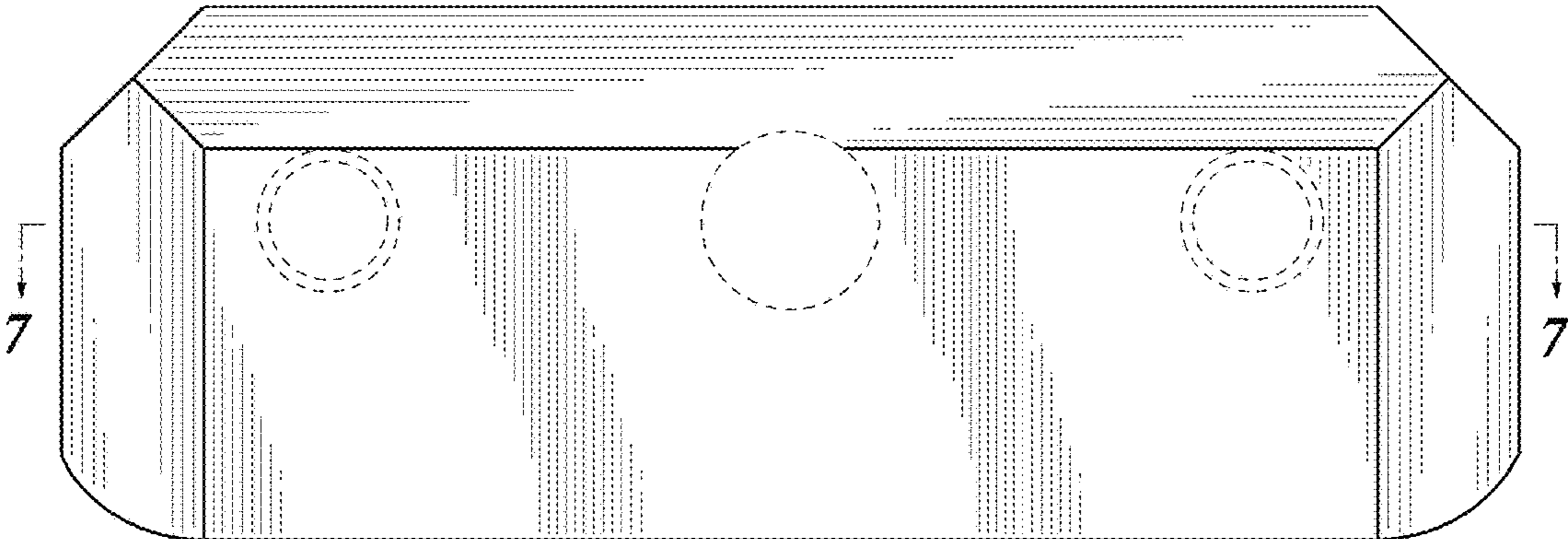

FIG. 3

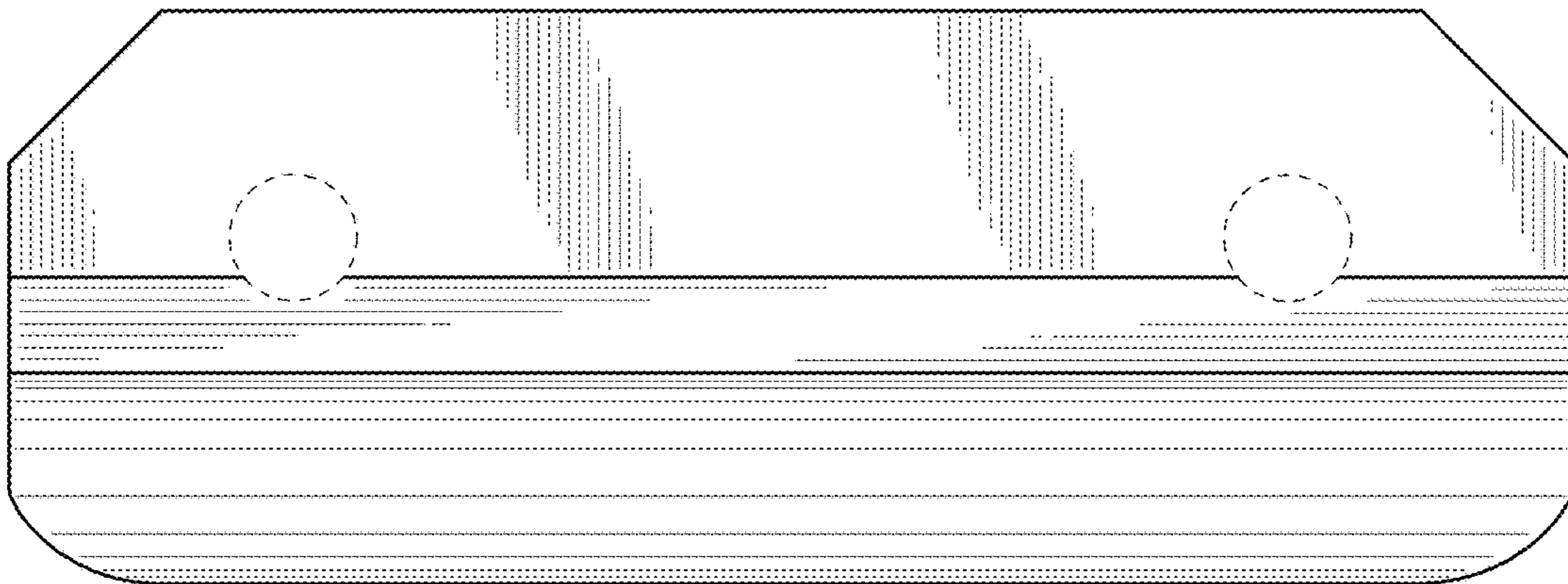

FIG. 4

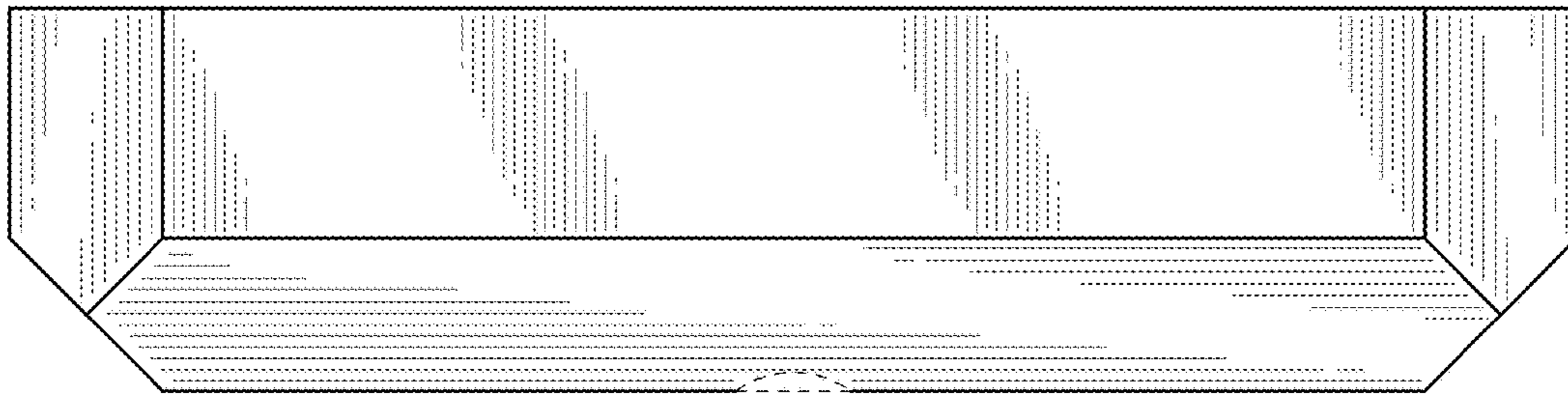

FIG. 5

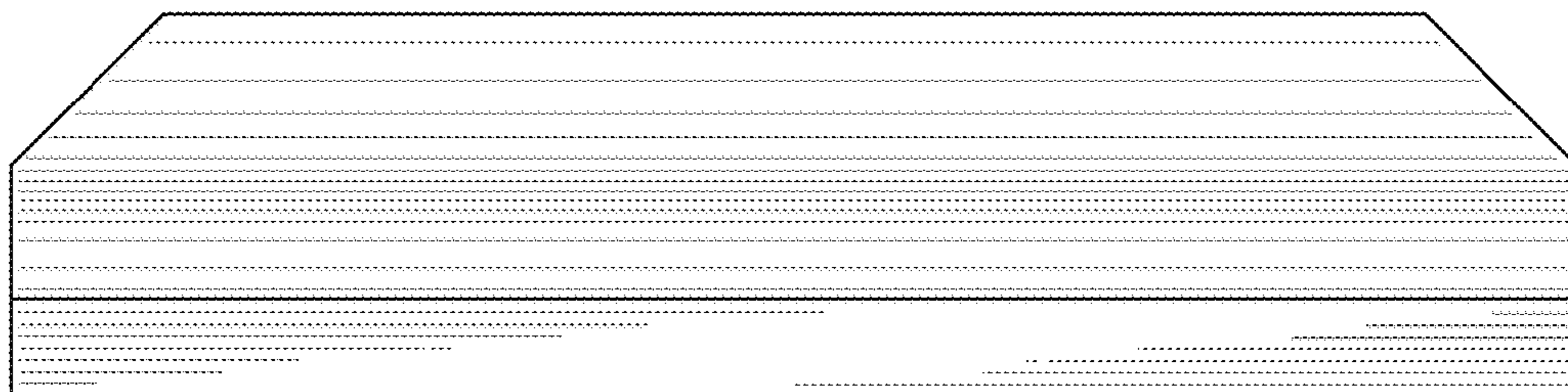

FIG. 6

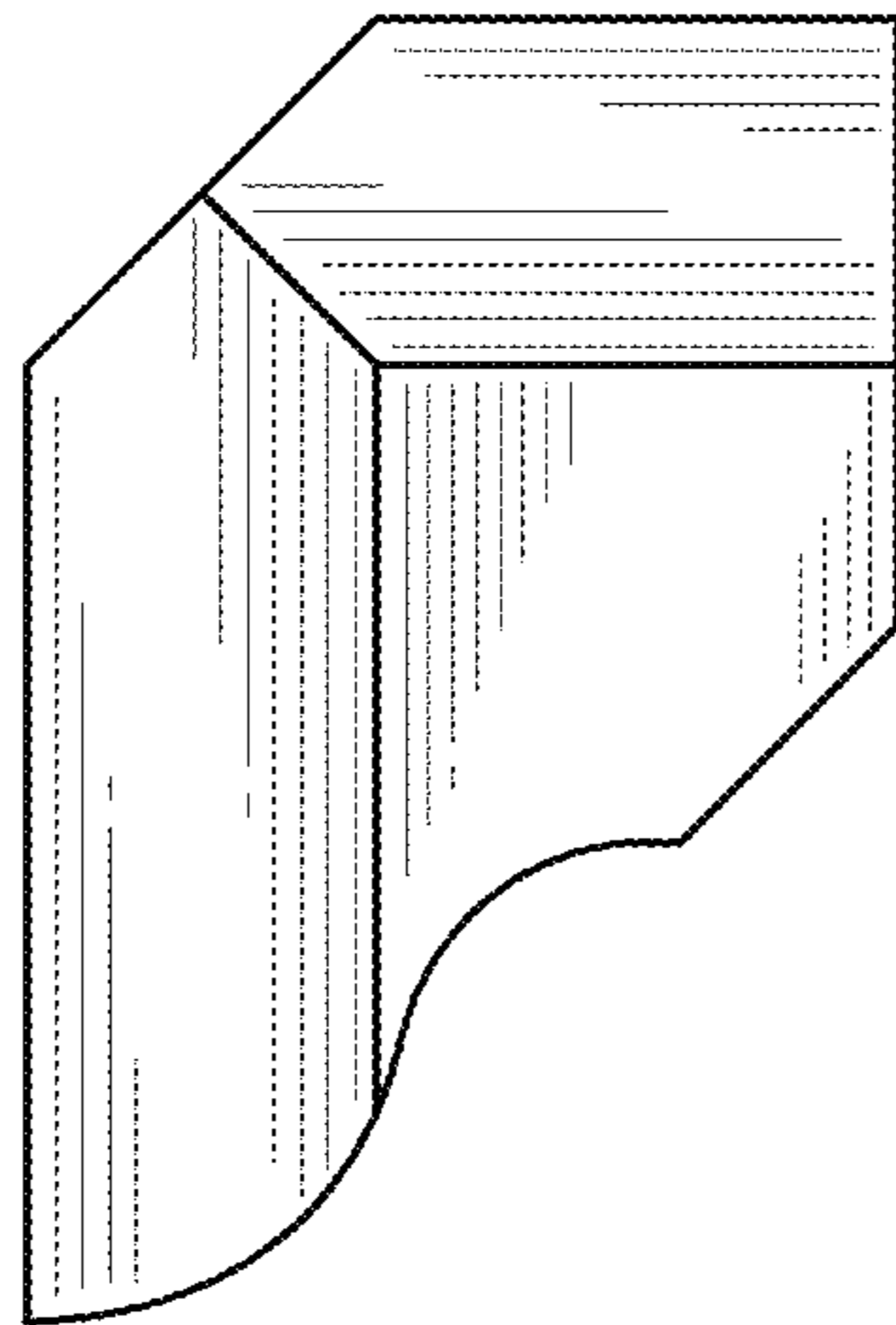

FIG. 7

