



US00D822644S

(12) **United States Design Patent** (10) **Patent No.:** **US D822,644 S**  
**Sandanger** (45) **Date of Patent:** **\*\* Jul. 10, 2018**

- (54) **SUB TRAGUS EAR UNIT**
- (71) Applicant: **Freebit AS**, Oslo (NO)
- (72) Inventor: **Vidar Sandanger**, Oslo (NO)
- (73) Assignee: **Freebit AS**, Oslo (NO)
- (\*\*) Term: **15 Years**
- (21) Appl. No.: **29/555,991**
- (22) Filed: **Feb. 26, 2016**

1,688,910 A	10/1928	Winship
1,753,817 A	4/1930	Aber
1,893,143 A	1/1933	Koch
1,969,559 A	8/1934	Kelly
2,437,490 A	3/1948	Gales
2,521,414 A	9/1950	Schier
2,545,731 A	3/1951	French
2,763,334 A	9/1956	Starkey
2,908,343 A	10/1959	Hummert
3,053,061 A	9/1962	French
3,157,245 A	11/1964	Bernstein
D221,442 S	8/1971	Feingold
4,010,820 A	3/1977	Johnson

(Continued)

**Related U.S. Application Data**

- (63) Continuation of application No. 14/417,284, filed as application No. PCT/NO2013/050126 on Jul. 29, 2013.

**Foreign Application Priority Data**

- Jul. 27, 2012 (EP) ..... 12178314

- (51) **LOC (11) Cl.** ..... **14-01**

- (52) **U.S. Cl.**  
USPC ..... **D14/223; D24/173**

- (58) **Field of Classification Search**  
USPC ..... D24/173-175; D14/205, 223-226, 249  
CPC .. H04R 2225/025; H04R 25/00; H04R 25/02;  
H04R 25/60; H04R 25/67; H04R 25/602;  
H04R 25/604; H04R 25/608; H04R  
1/1016; H04R 1/105; H04R 1/1083; A61F  
11/08

See application file for complete search history.

(56) **References Cited**

**U.S. PATENT DOCUMENTS**

588,099 A	8/1897	Blount et al.
931,768 A	8/1909	Kirkpatrick
1,564,474 A	12/1925	Fensky
1,614,987 A	1/1927	Langenbeck et al.
1,668,890 A	5/1928	Curran et al.

**FOREIGN PATENT DOCUMENTS**

CN	200430074797.7 A	3/2005
DE	29718483 U1	2/1999

(Continued)

*Primary Examiner* — Thomas Johannes

*Assistant Examiner* — Samantha Q. Lawrence

(74) *Attorney, Agent, or Firm* — Abelman, Frayne & Schwab

(57) **CLAIM**

The ornamental design for a sub tragus ear unit, as shown and described.

**DESCRIPTION**

FIG. 1 is a front, right side, and top perspective view of a sub tragus ear unit showing the new design;  
 FIG. 2 is a top plan thereof;  
 FIG. 3 is a front elevation thereof;  
 FIG. 4 is a right side elevation thereof;  
 FIG. 5 is a rear elevation thereof;  
 FIG. 6 is a left side elevation thereof; and,  
 FIG. 7 is a bottom plan thereof.  
 The broken lines illustrate portions of the sub tragus ear unit and form no part of the claimed design.

**1 Claim, 4 Drawing Sheets**

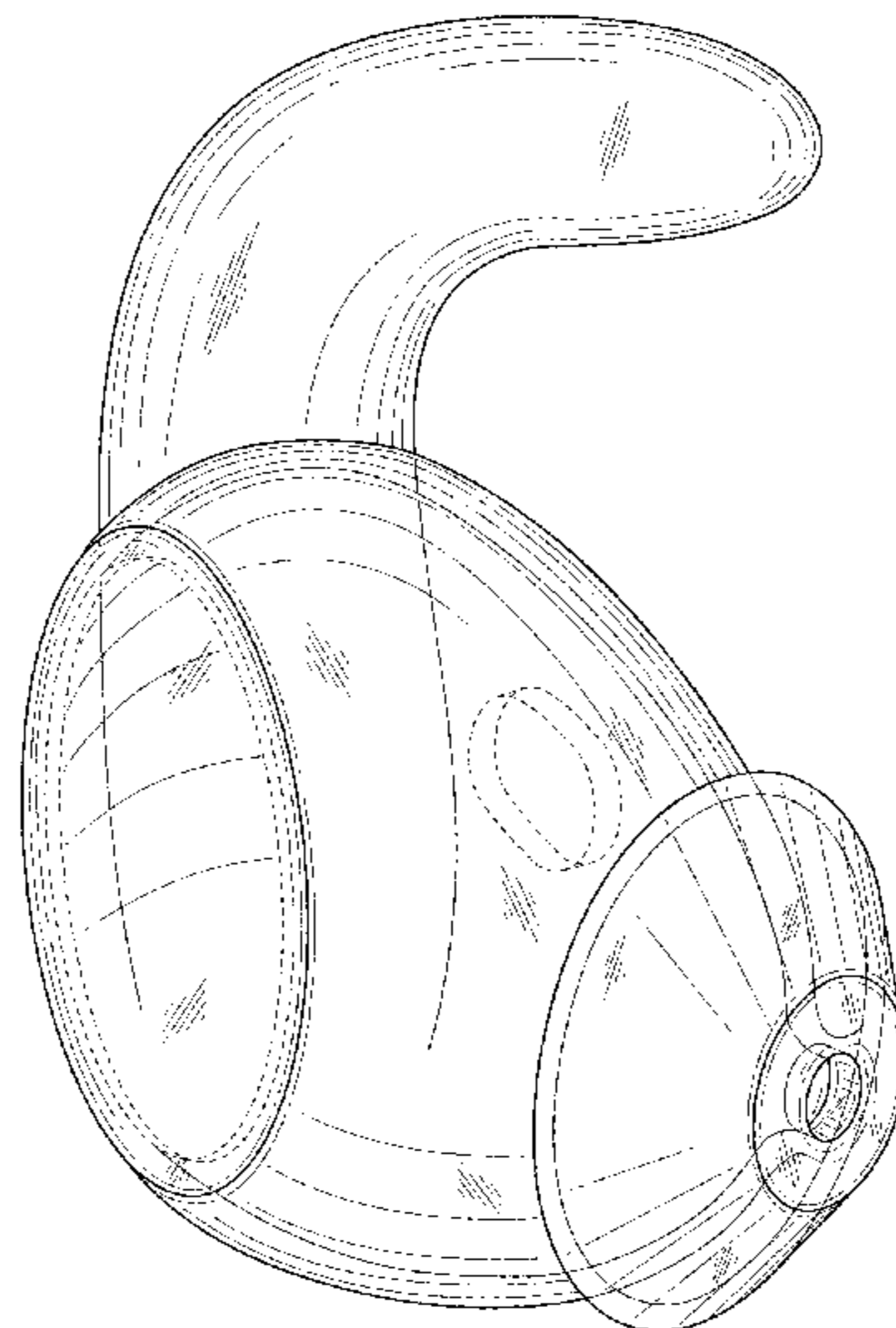

(56)

References Cited

U.S. PATENT DOCUMENTS

4,055,233 A 10/1977 Huntress  
 4,219,018 A 8/1980 Draper, Jr.  
 D266,590 S 10/1982 Bennett  
 4,353,364 A 10/1982 Woods  
 D274,814 S 7/1984 Tang  
 4,540,063 A 9/1985 Ochi et al.  
 4,646,872 A 3/1987 Kamon et al.  
 4,896,679 A 1/1990 St Pierre  
 D316,550 S 4/1991 Sogabe  
 D318,670 S 7/1991 Taniguchi  
 5,048,090 A 9/1991 Geers  
 5,055,233 A 10/1991 Borland et al.  
 D326,655 S 6/1992 Iribe  
 5,222,151 A 6/1993 Nagayoshi et al.  
 5,548,643 A 8/1996 Dalglish et al.  
 5,625,171 A 4/1997 Marshall  
 5,654,530 A 8/1997 Sauer et al.  
 5,668,354 A 9/1997 Falco  
 D388,093 S 12/1997 Frengley  
 5,712,453 A 1/1998 Bungardt et al.  
 5,727,566 A 3/1998 Leight  
 5,957,136 A 9/1999 Magidson et al.  
 D430,139 S 8/2000 Peters et al.  
 D430,547 S 9/2000 Yoon  
 D430,860 S 9/2000 Yoon  
 6,129,175 A 10/2000 Tutor et al.  
 6,241,041 B1 6/2001 Leight  
 6,449,374 B1 9/2002 Skulley et al.  
 D469,755 S 2/2003 Hlas et al.  
 D470,122 S 2/2003 Hlas et al.  
 D470,123 S 2/2003 Hlas et al.  
 D470,128 S 2/2003 Hlas et al.  
 D470,129 S 2/2003 Hlas et al.  
 D471,537 S 3/2003 Ham  
 D471,890 S 3/2003 Clarkson  
 D473,204 S 4/2003 Tanio  
 D478,991 S 8/2003 Dyer et al.  
 6,690,807 B1 2/2004 Köchler  
 6,795,718 B2 9/2004 Bae  
 D497,000 S \* 10/2004 Narisawa ..... D24/173  
 6,819,762 B2 11/2004 Jones et al.  
 6,820,717 B2 11/2004 Fleming et al.  
 D501,196 S \* 1/2005 Dyer ..... D14/205  
 6,868,284 B2 3/2005 Bae  
 6,879,697 B2 4/2005 Topholm  
 D505,132 S 5/2005 Linville et al.  
 6,944,307 B2 9/2005 Berg  
 D510,574 S 10/2005 Okada  
 6,961,440 B1 11/2005 Schlaegel  
 7,050,599 B2 5/2006 Baskerville  
 7,068,803 B2 6/2006 Kuhlmann et al.  
 D525,962 S 8/2006 Elson  
 D538,271 S 3/2007 Kim et al.  
 7,233,676 B2 6/2007 Bayer  
 D558,735 S 1/2008 Carr et al.  
 7,340,075 B2 3/2008 Bayer  
 D566,099 S 4/2008 Komiyama  
 D566,691 S 4/2008 Andre et al.  
 D568,302 S 5/2008 Oh  
 D569,841 S 5/2008 Chung et al.  
 7,394,910 B2 7/2008 Smith et al.  
 D575,277 S 8/2008 Gaarde et al.  
 D575,772 S 8/2008 Schultz et al.  
 7,412,068 B2 8/2008 Bayer  
 D578,507 S 10/2008 Ando  
 D578,508 S 10/2008 Wang  
 D579,006 S 10/2008 Kim et al.  
 D582,389 S 12/2008 Bose et al.  
 D582,397 S 12/2008 Christopher  
 D582,398 S 12/2008 Nam et al.  
 D582,889 S 12/2008 Bose et al.  
 D584,284 S 1/2009 Carr et al.  
 D584,294 S 1/2009 Nam et al.  
 D585,881 S 2/2009 Nam et al.  
 D588,099 S 3/2009 Yuyama

D589,945 S 4/2009 Esses  
 7,536,008 B2 5/2009 Howes et al.  
 D596,164 S 7/2009 Henning  
 D601,134 S 9/2009 Elabidi et al.  
 D602,476 S 10/2009 Lee et al.  
 D605,170 S 12/2009 Keinanen  
 D605,628 S 12/2009 Ando  
 D607,875 S 1/2010 Pedersen, II  
 D618,219 S 6/2010 Burgett et al.  
 D618,221 S 6/2010 Fahrendorff et al.  
 D620,927 S 8/2010 Li  
 D621,817 S 8/2010 Brickstad  
 D622,265 S 8/2010 Rye  
 D622,704 S 8/2010 Fahrendorff et al.  
 7,778,410 B2 8/2010 Liu et al.  
 7,778,435 B2 8/2010 Smith et al.  
 D628,188 S 11/2010 Koch  
 D633,481 S 3/2011 Chen  
 D634,305 S 3/2011 Hoggarth  
 7,949,127 B2 5/2011 Pedersen et al.  
 D640,670 S 6/2011 Rye  
 7,965,855 B1 6/2011 Ham  
 D641,747 S 7/2011 Gisborne  
 D645,458 S \* 9/2011 Silvestri ..... H04R 1/1016  
 D655,693 S \* 3/2012 Silvestri ..... D14/223  
 D664,124 S \* 7/2012 Smith ..... D14/223  
 8,538,056 B2 9/2013 Ishibashi et al.  
 D726,147 S \* 4/2015 Tran ..... D14/206  
 9,161,114 B2 10/2015 Bone et al.  
 D744,456 S \* 12/2015 Pedersen ..... D14/223  
 D754,638 S 4/2016 Krissman  
 D758,355 S \* 6/2016 Lee ..... D14/223  
 9,398,365 B2 7/2016 Liu et al.  
 9,401,158 B1 7/2016 Yen et al.  
 D763,224 S \* 8/2016 Silvestri ..... H04R 1/1016  
 D773,440 S \* 12/2016 Pedersen ..... D14/223  
 D773,441 S \* 12/2016 Pedersen ..... D14/223  
 D774,021 S \* 12/2016 Pedersen ..... D14/223  
 D779,461 S \* 2/2017 Smith ..... D14/223  
 2002/0096391 A1 7/2002 Smith  
 2002/0172386 A1 11/2002 Bayer  
 2003/0091210 A1 5/2003 Baskerville  
 2003/0174853 A1 9/2003 Howes  
 2004/0045558 A1 3/2004 Taylor  
 2004/0163653 A1 8/2004 Fleming  
 2005/0008180 A1 1/2005 Smith  
 2006/0067556 A1 3/2006 Bailey et al.  
 2006/0177080 A1 8/2006 Smith  
 2006/0188122 A1 8/2006 Smith  
 2006/0215864 A1 9/2006 Espersen et al.  
 2007/0116309 A1 5/2007 Smith  
 2007/0183615 A1 8/2007 Wurfel  
 2007/0254725 A1 11/2007 Smith  
 2008/0085030 A1 4/2008 Smith  
 2008/0159577 A1 7/2008 Smith  
 2008/0181441 A1 7/2008 Smith  
 2008/0247561 A1 10/2008 Smith  
 2009/0092269 A1 4/2009 Nielsen et al.  
 2009/0141923 A1 6/2009 Smith  
 2009/0180654 A1 7/2009 Nielsen  
 2009/0202094 A1 8/2009 Ammitzball  
 2009/0226025 A1 9/2009 Howes et al.  
 2009/0323993 A1 12/2009 Slemming et al.  
 2010/0278364 A1 11/2010 Berg  
 2012/0321114 A1 12/2012 Ishibashi

FOREIGN PATENT DOCUMENTS

DE 202011002165 U1 5/2011  
 EP 1377113 A2 1/2004  
 EP 786241 B1 7/2004  
 EP 1594340 A1 11/2005  
 EP 368125 A2 7/2008  
 JP 2001333484 A 11/2001  
 JP 2005184579 A 7/2005  
 WO 2001050813 A2 7/2001  
 WO 2001050993 A1 7/2001

(56)

**References Cited**

FOREIGN PATENT DOCUMENTS

WO	2002045390	A1	6/2002
WO	2006104981	A2	10/2006
WO	2008147215	A1	12/2008
WO	2009030229	A1	3/2009
WO	2010031775	A1	3/2010
WO	2010040350	A1	4/2010
WO	2010040351	A1	4/2010

\* cited by examiner

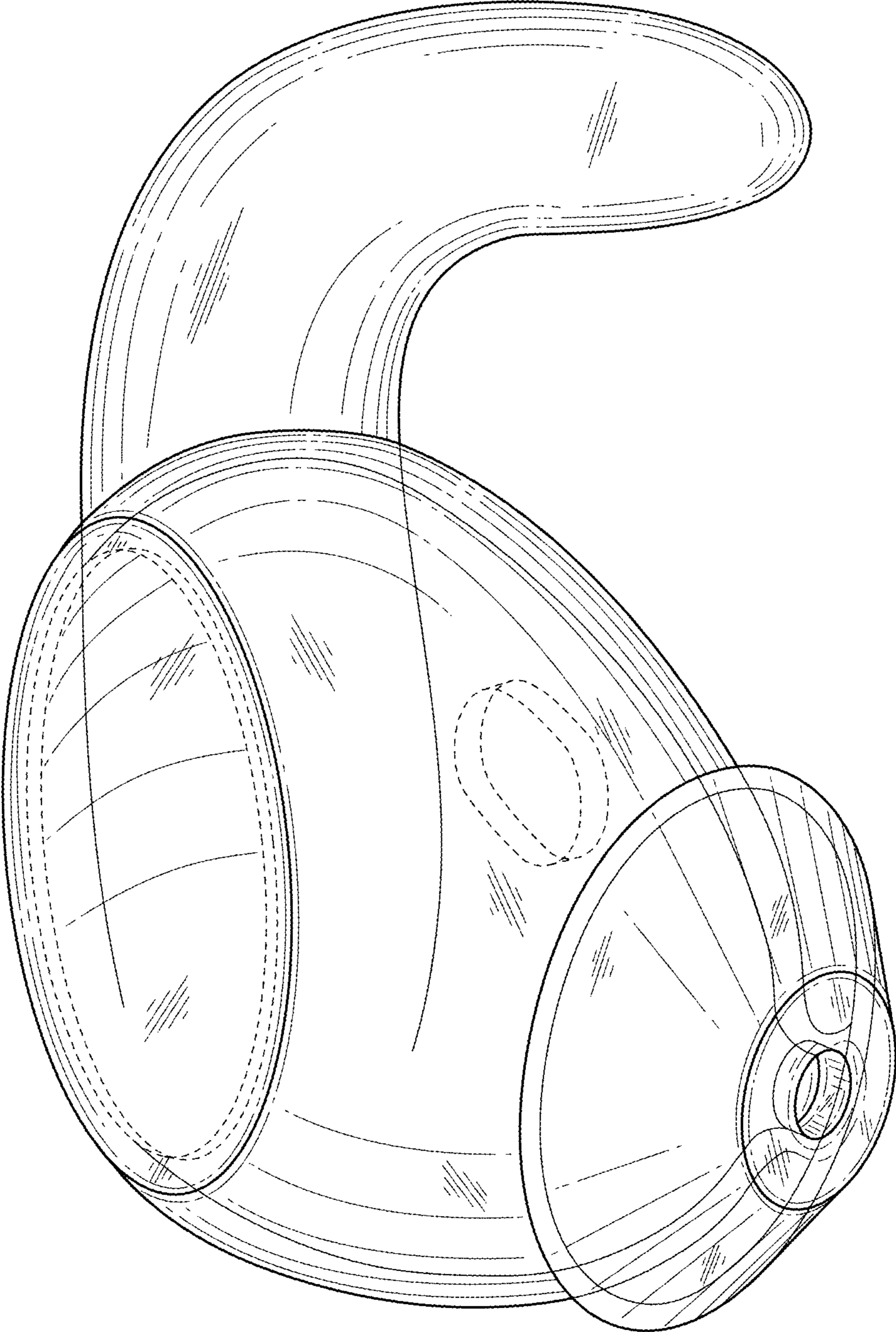

FIG. 1

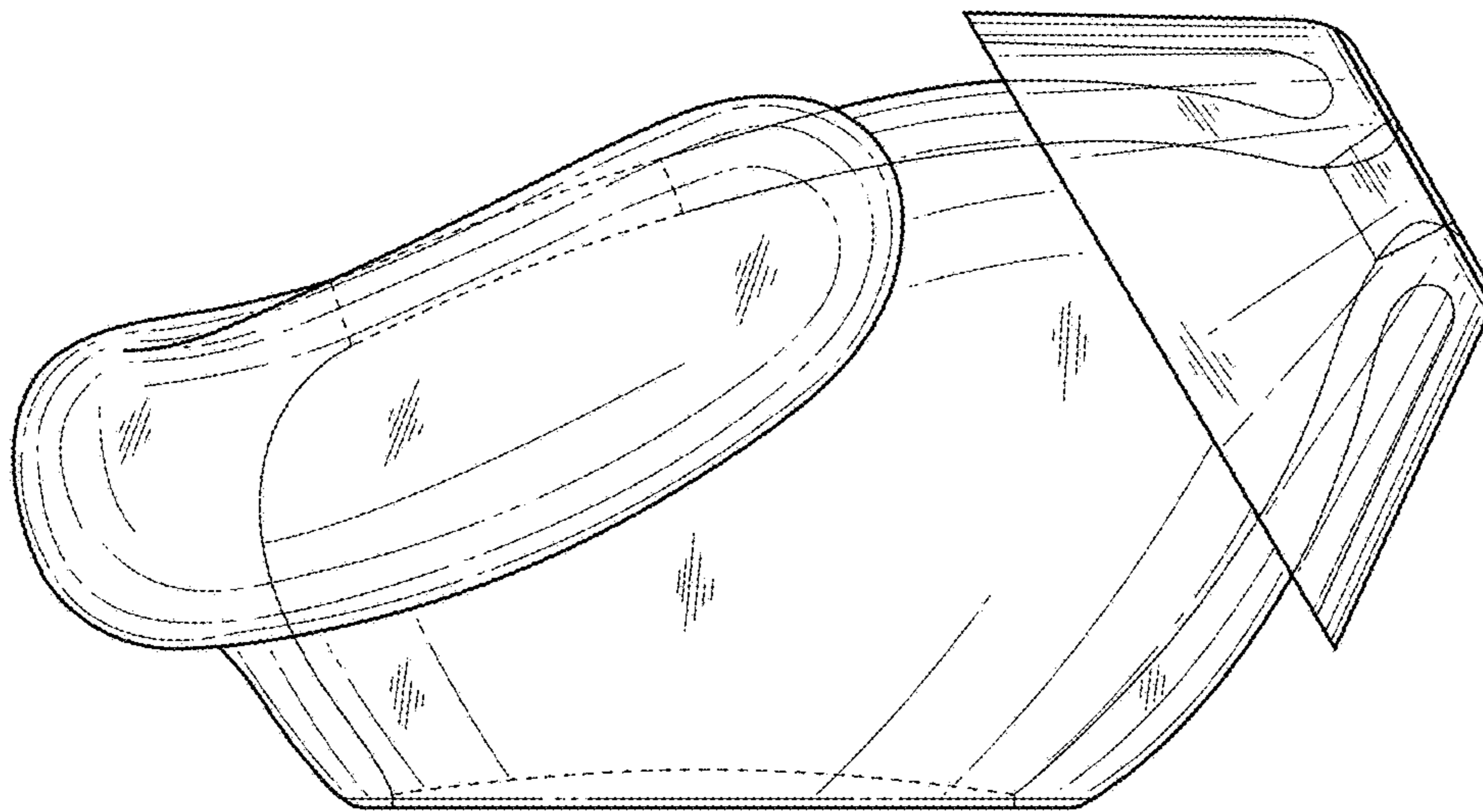

FIG. 2

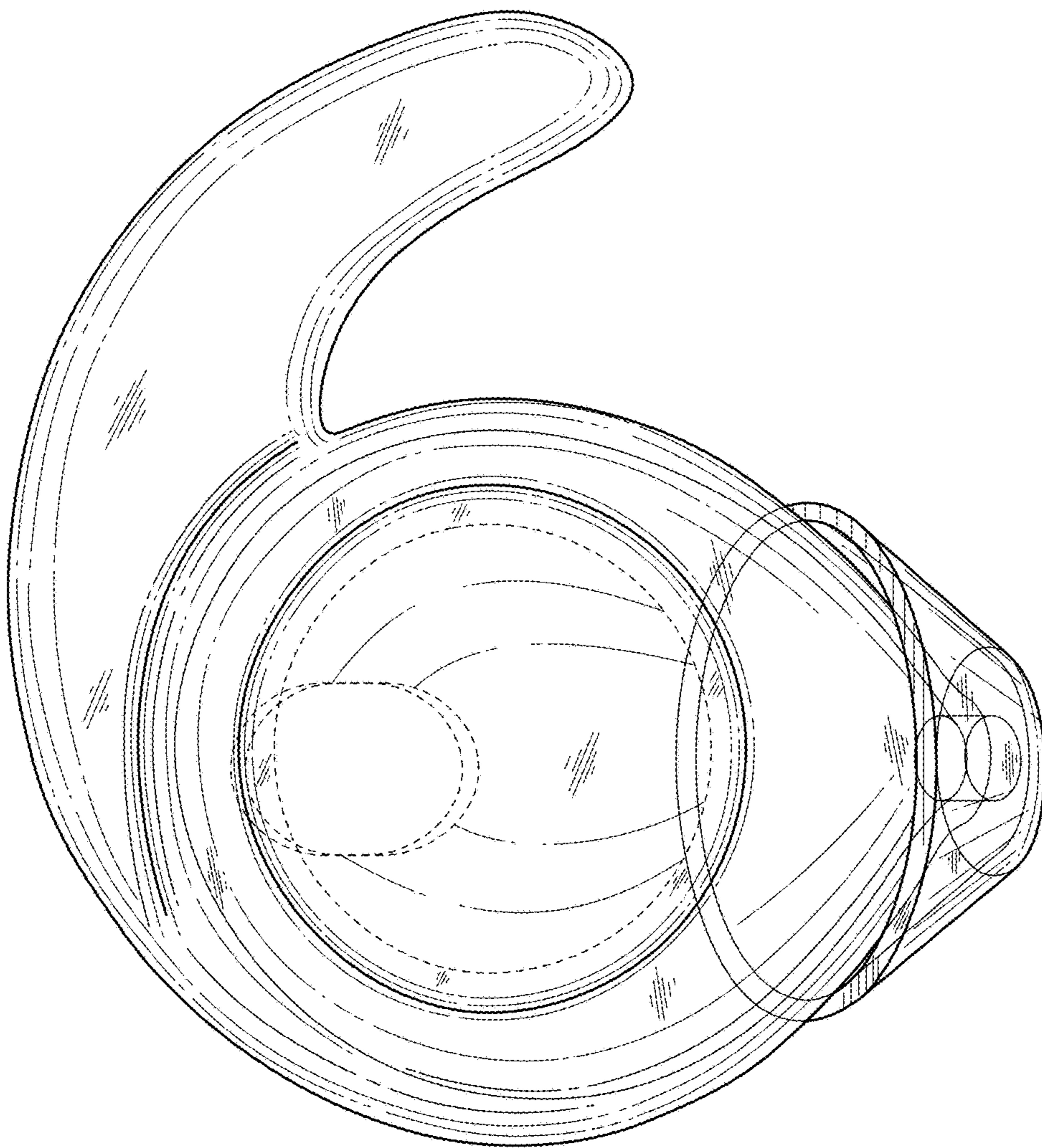

FIG. 3

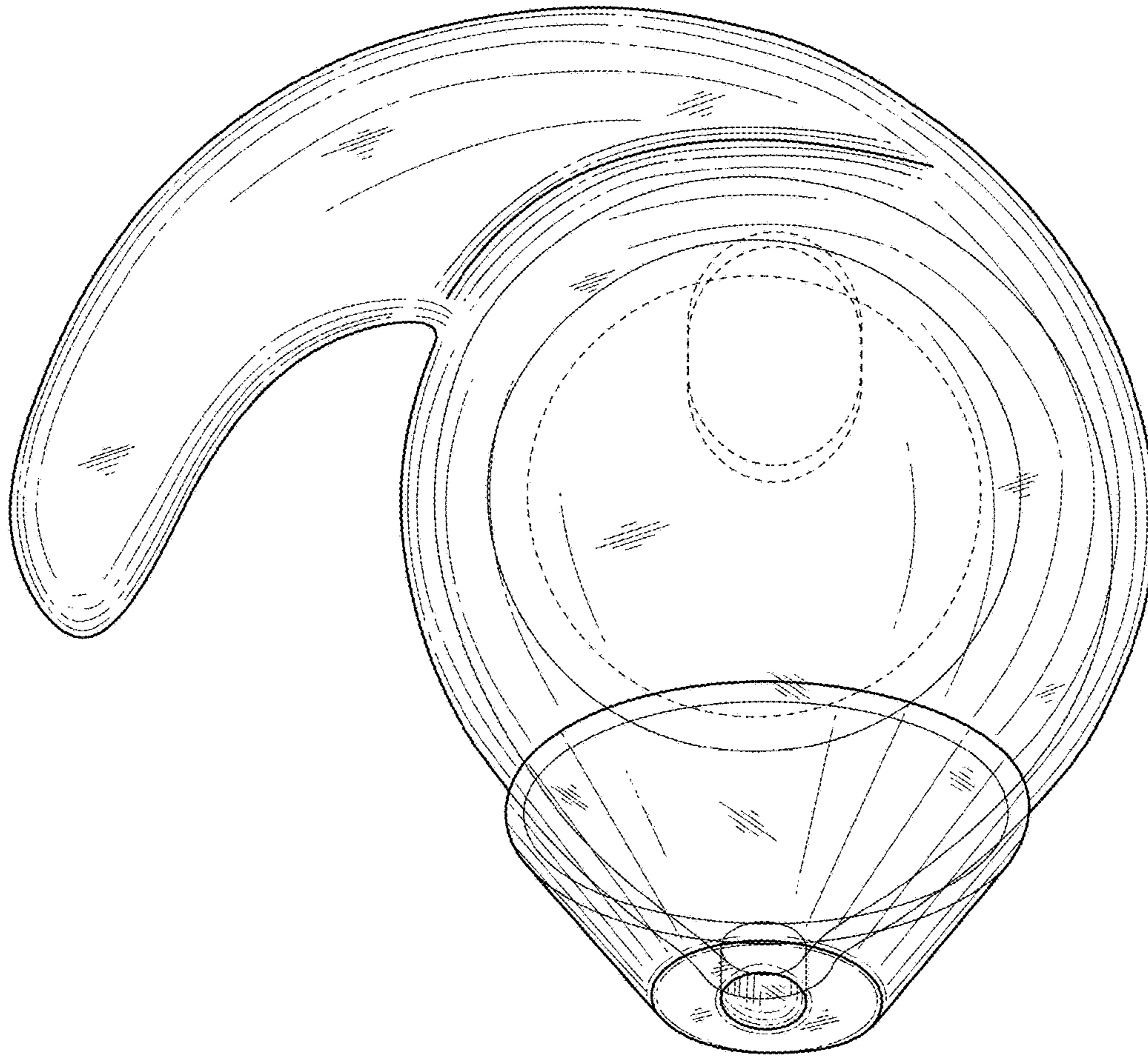

FIG. 5

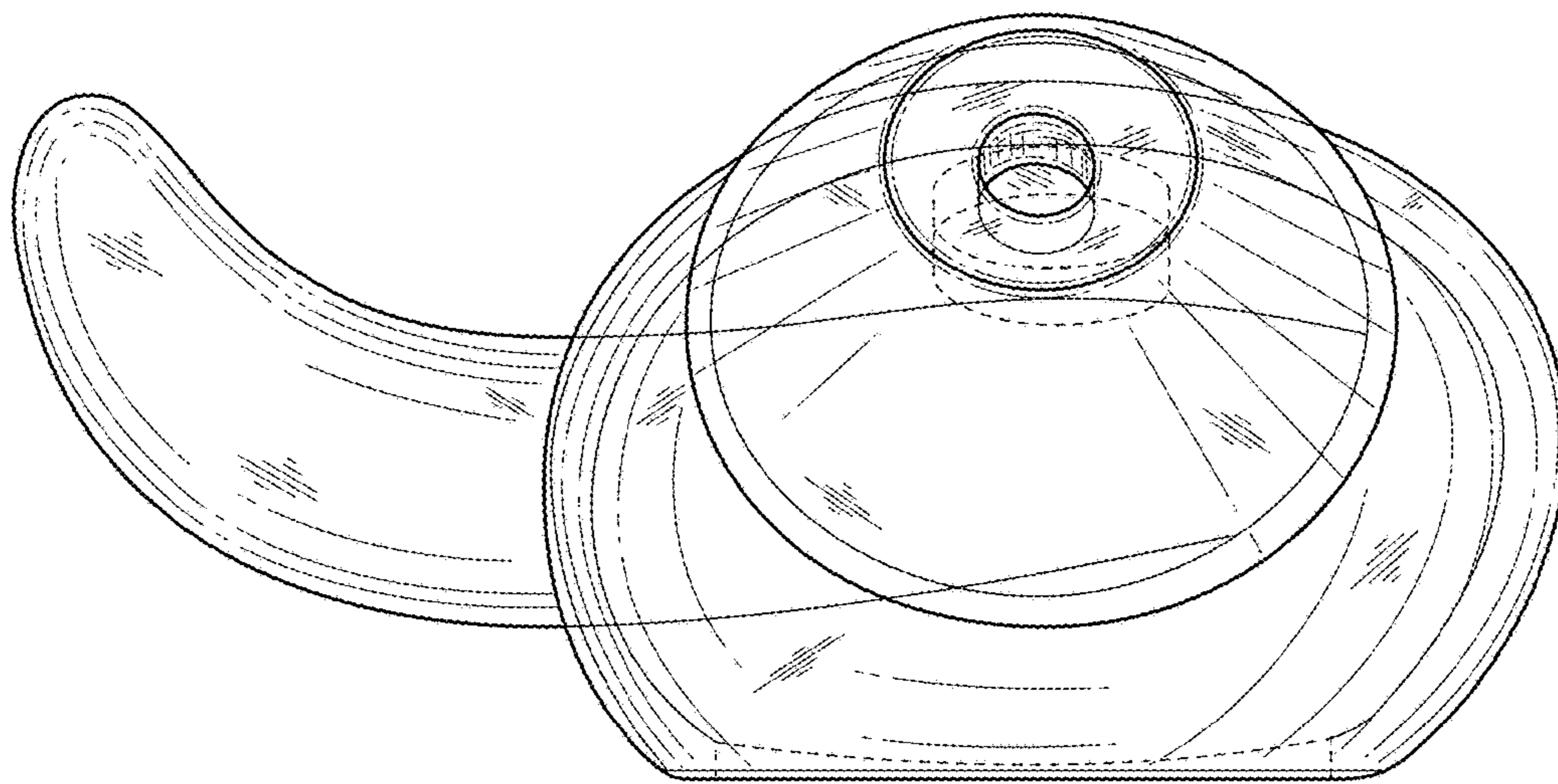

FIG. 4

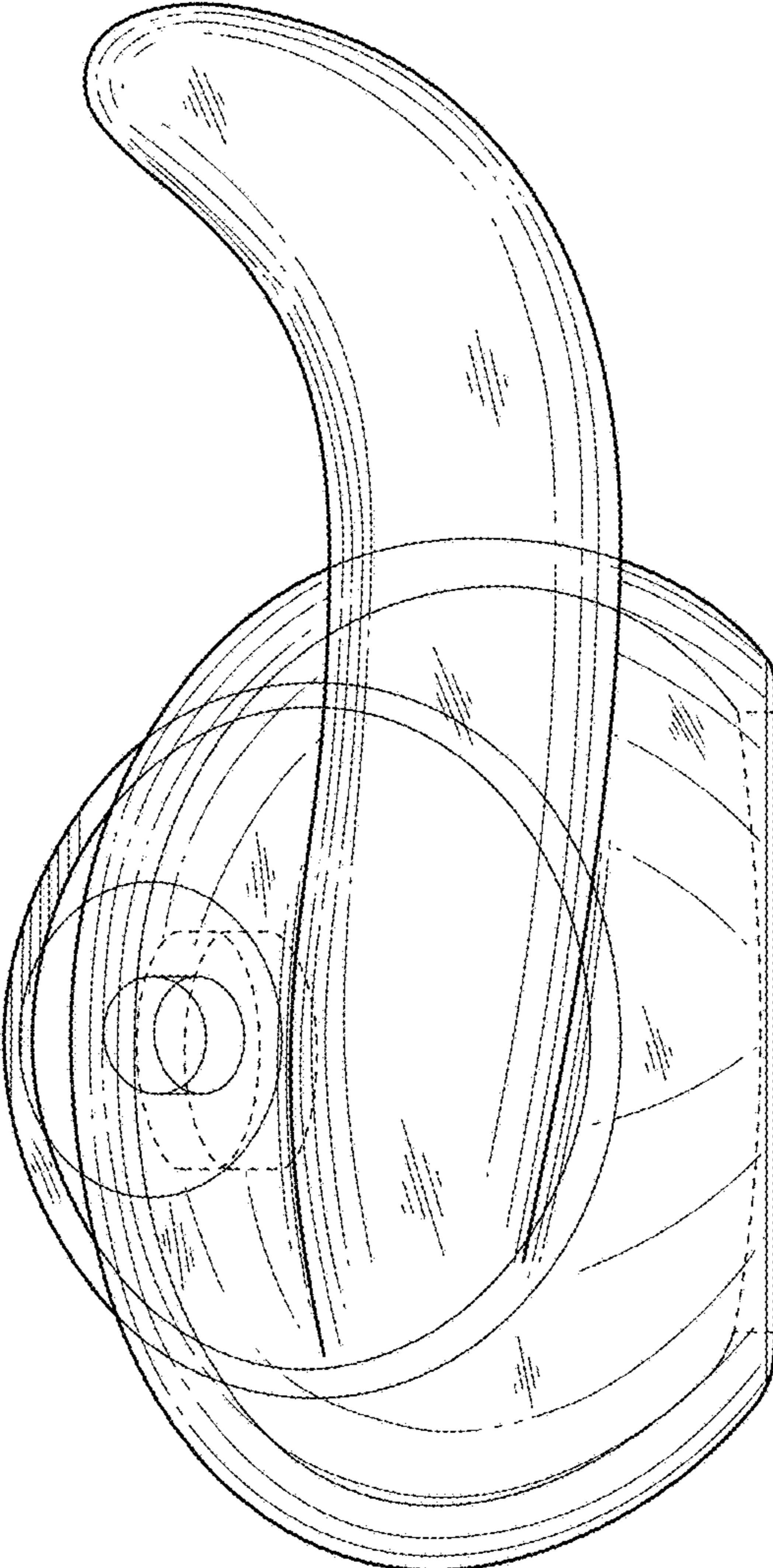

FIG. 6

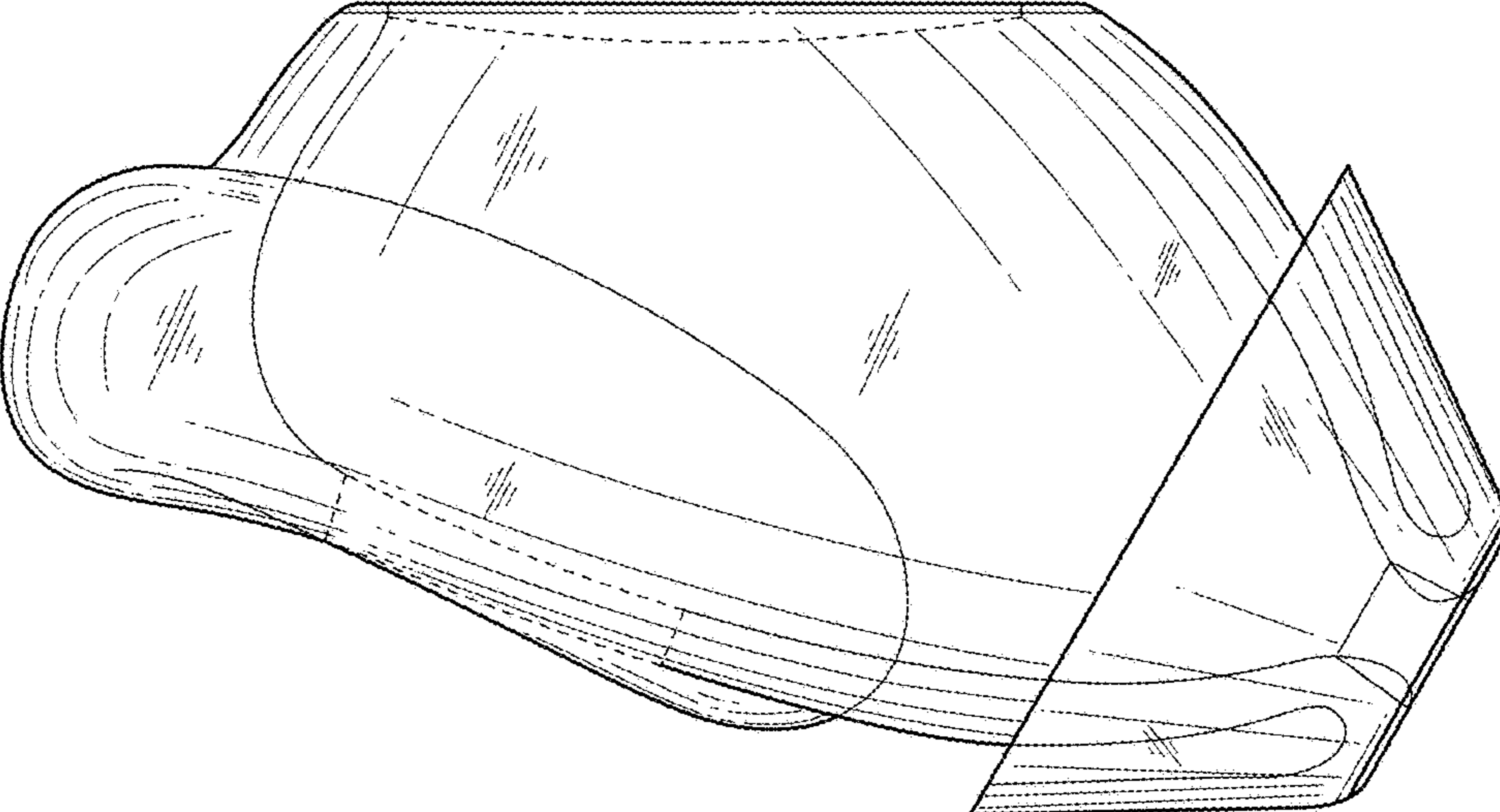

FIG. 7