



US00D822542S

(12) **United States Design Patent** (10) **Patent No.:** **US D822,542 S**
Ancona (45) **Date of Patent:** **** Jul. 10, 2018**

(54) **MOTOR VEHICLE**
(71) Applicant: **THE LONDON TAXI CORPORATION LIMITED**, Coventry (GB)
(72) Inventor: **David Ancona**, Barcelona (ES)
(**) Term: **15 Years**

D587,170 S * 2/2009 Tokoro D12/91
D605,556 S * 12/2009 Zheng D12/91
D615,456 S * 5/2010 Booth D12/91
D615,457 S * 5/2010 Booth D12/91
D678,821 S * 3/2013 Ikeda D12/91
D679,628 S * 4/2013 Darwish D12/91
D699,629 S * 2/2014 Ikeda D12/91
D716,696 S * 11/2014 Thole D12/91
D717,696 S * 11/2014 Thole D12/91
D722,533 S * 2/2015 Thole D12/91
D793,283 S * 8/2017 Woodhouse D12/91

(21) Appl. No.: **35/501,133**

FOREIGN PATENT DOCUMENTS

(22) Filed: **Oct. 20, 2015**

EM 000638390-0001 2/2007

(80) **Hague Agreement Data**

* cited by examiner

Int. Filing Date: **Oct. 20, 2015**
Int. Reg. No.: **DM/091054**
Int. Reg. Date: **Oct. 20, 2015**
Int. Reg. Pub. Date: **Jun. 24, 2016**

Primary Examiner — Darlington Ly
(74) *Attorney, Agent, or Firm* — Snell & Wilmer L.L.P.

(51) **LOC (11) Cl.** **12-08**

(57) **CLAIM**

(52) **U.S. Cl.**
USPC **D12/91**

The ornamental design for a motor vehicle, as shown and described.

(58) **Field of Classification Search**
USPC D12/86, 90, 91, 92, 98; D21/424, 433, D21/434
CPC B62D 25/00; B62D 25/06; B62D 33/00; B62D 35/00

DESCRIPTION

See application file for complete search history.

1. Motor vehicles
1.1 is a front and right side perspective of a motor vehicle showing the new design;
1.2 is a rear and right side perspective view thereof;
1.3 is a front elevation view thereof;
1.4 is a rear elevation view thereof;
1.5 is a right side elevation view thereof; and
1.6 is a top plan view thereof.

(56) **References Cited**

U.S. PATENT DOCUMENTS

D406,549 S * 3/1999 Bailey D12/91
D453,712 S * 2/2002 Pasteiner D12/91
D502,672 S * 3/2005 Hannona D12/91
D533,113 S * 12/2006 Cartabiano D12/91
D534,097 S * 12/2006 Renkert D12/91
D567,144 S * 4/2008 Pocobello D12/86

No protection is sought for the matters shown in dotted lines. The broken lines in the reproductions illustrate portions of the motor vehicle that do not form part of the claimed design.

1 Claim, 6 Drawing Sheets

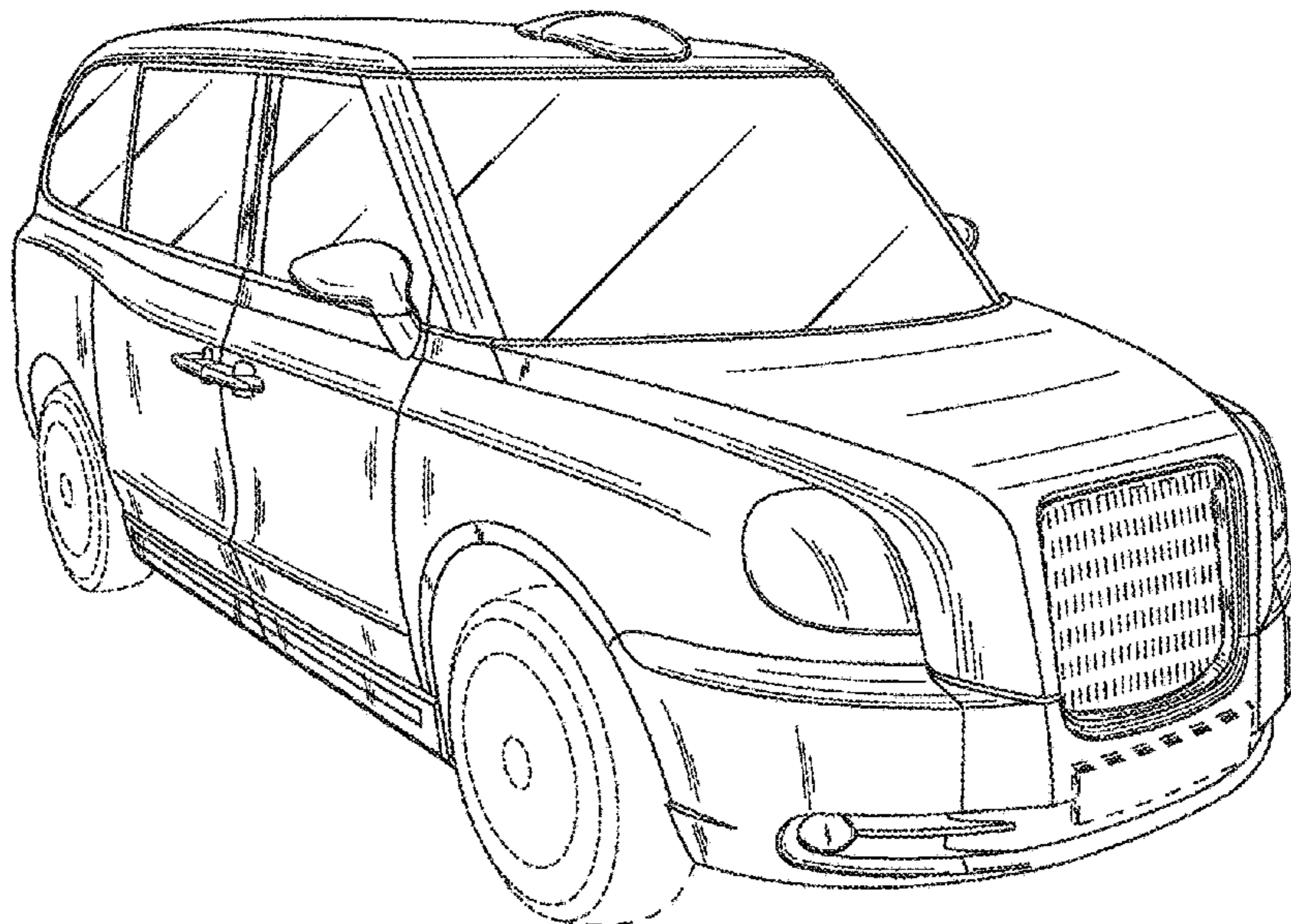

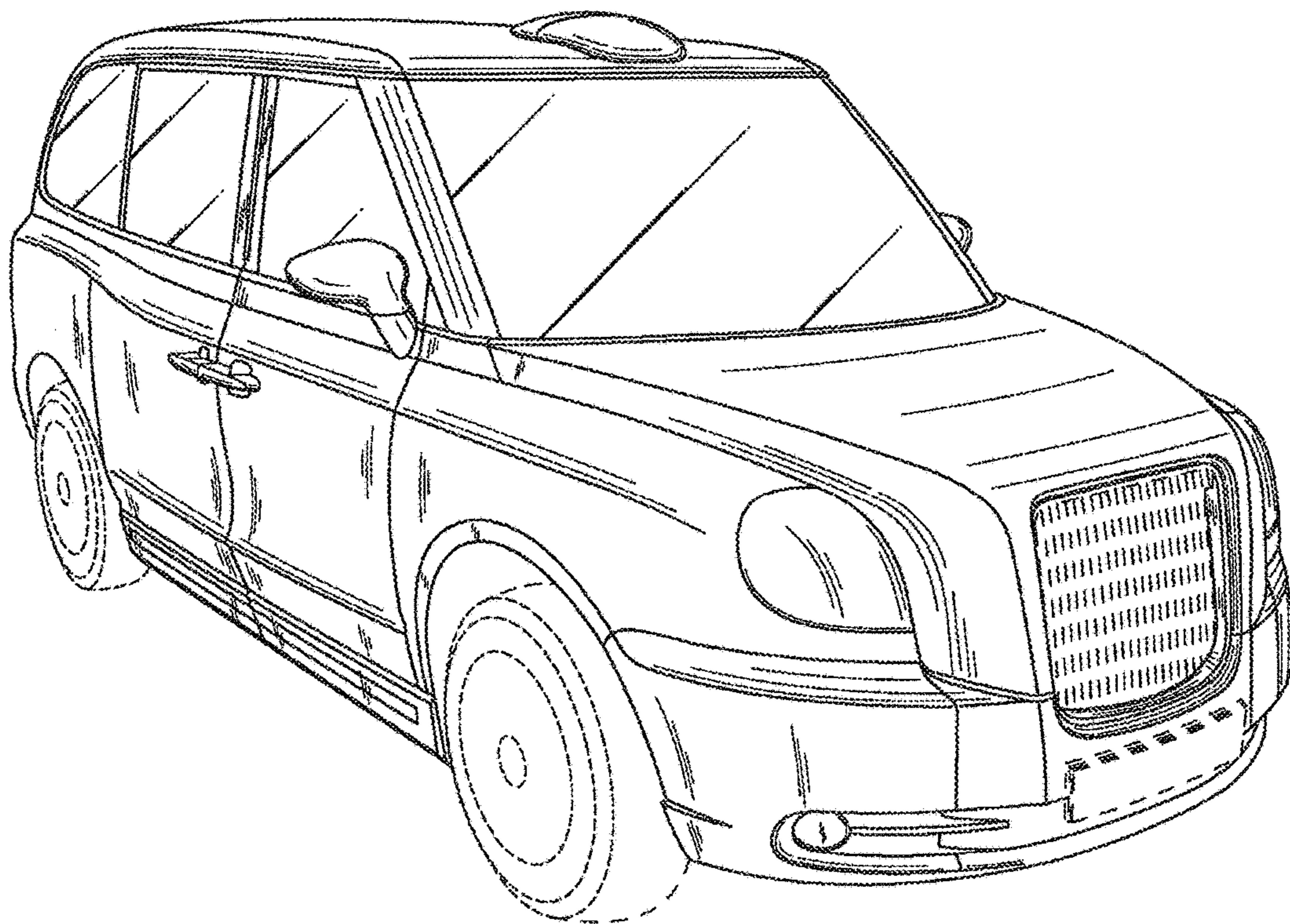

FIG. 1.1

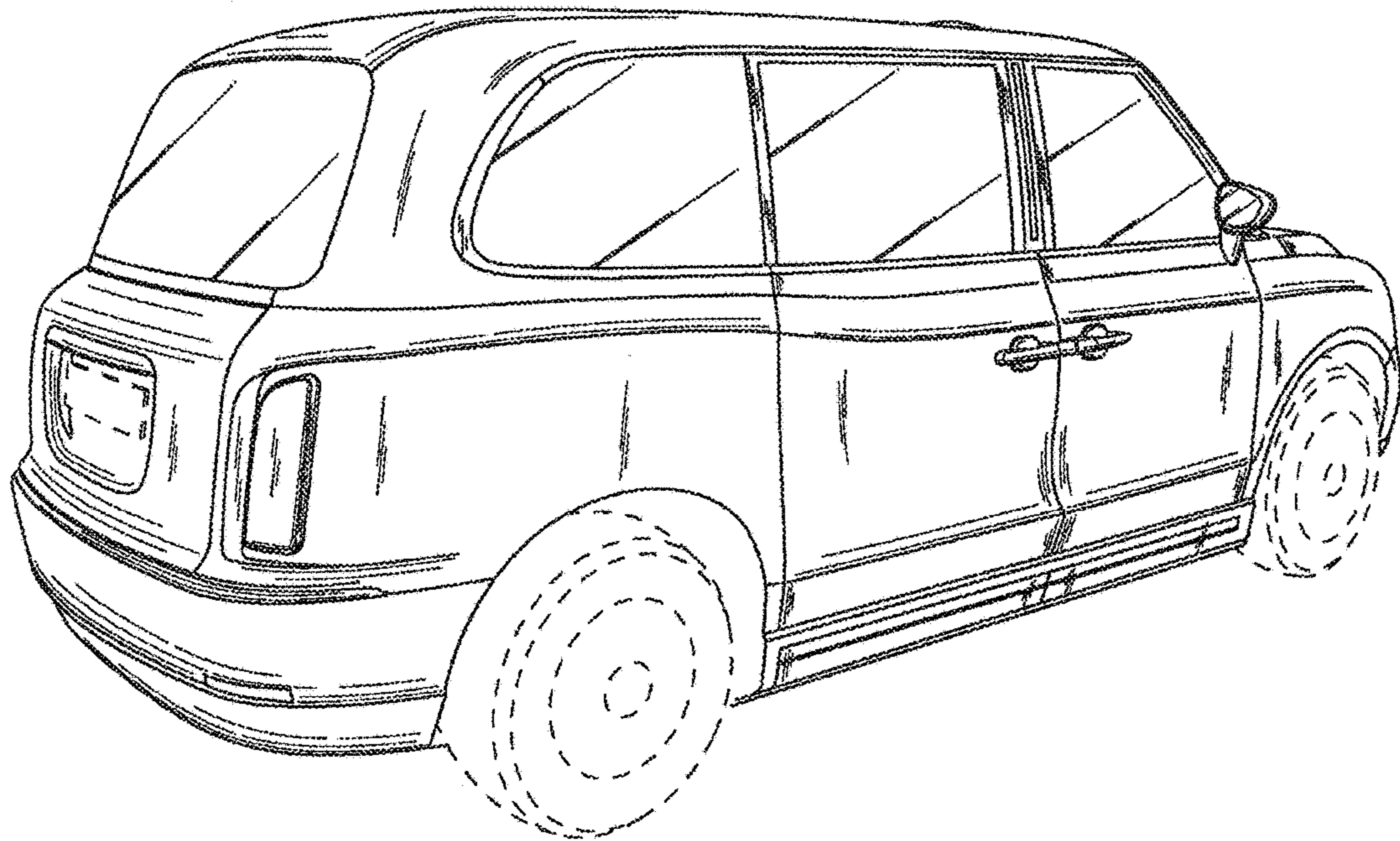

FIG. 1.2

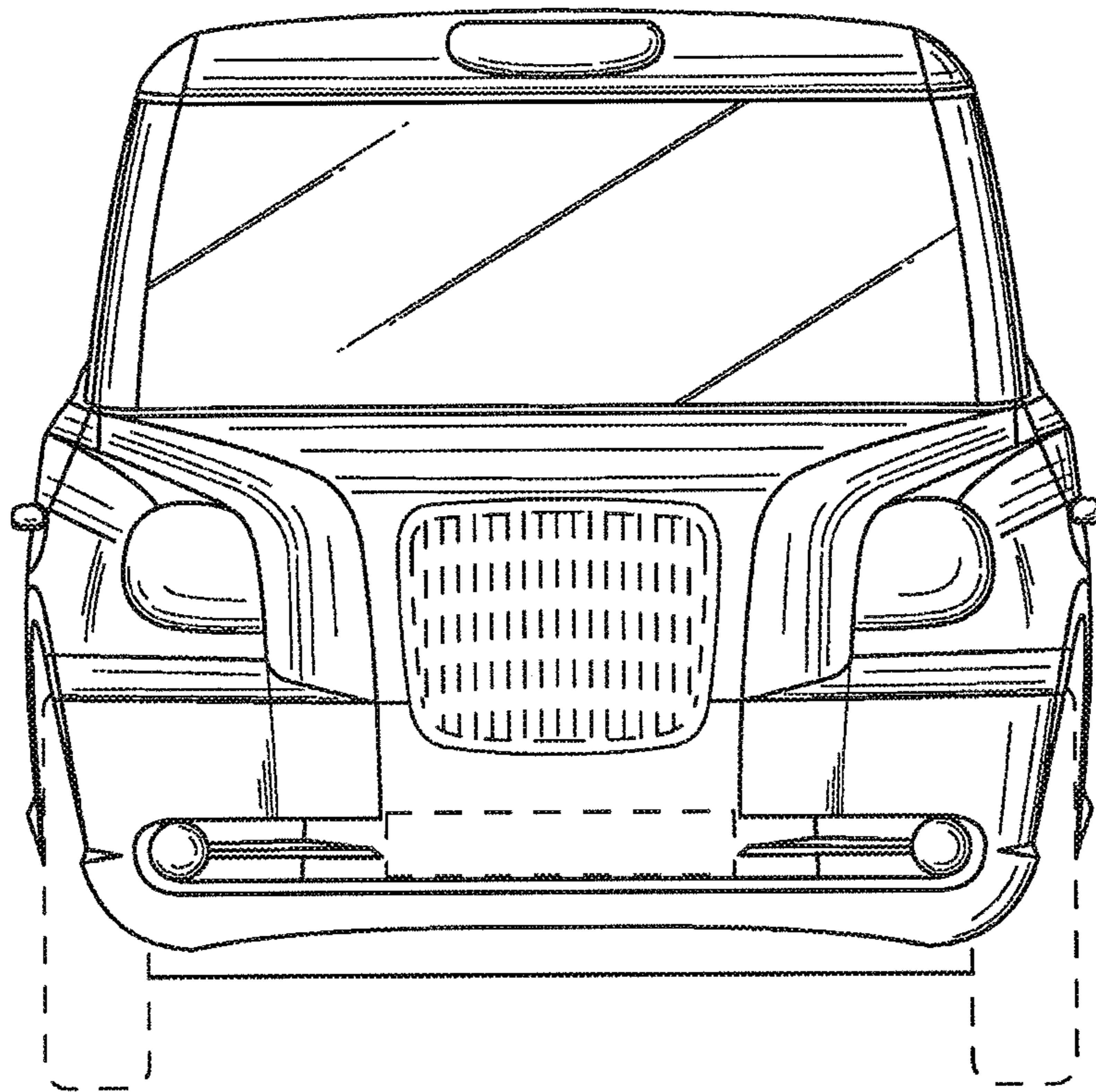

FIG. 1.3

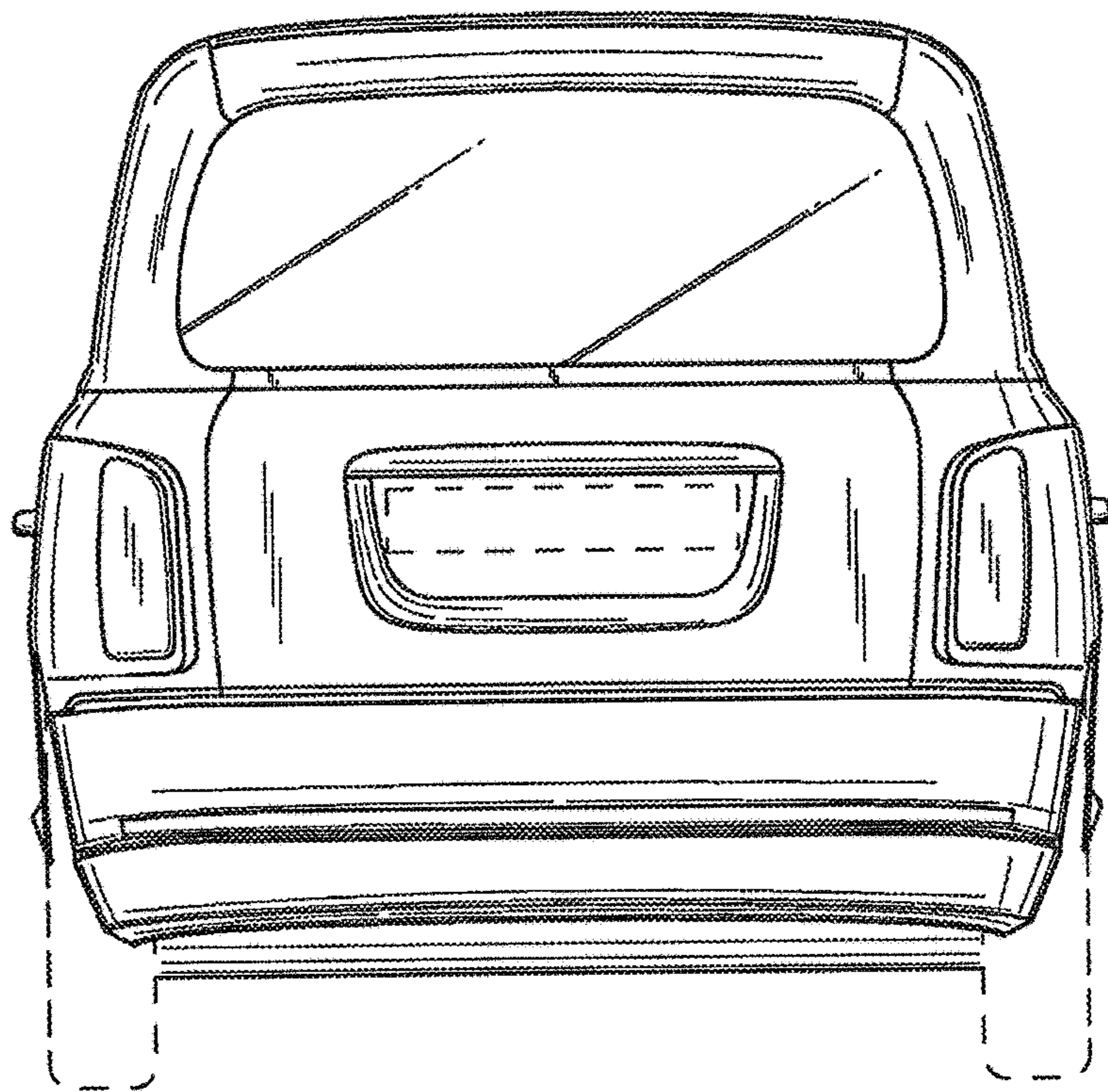

FIG. 1.4

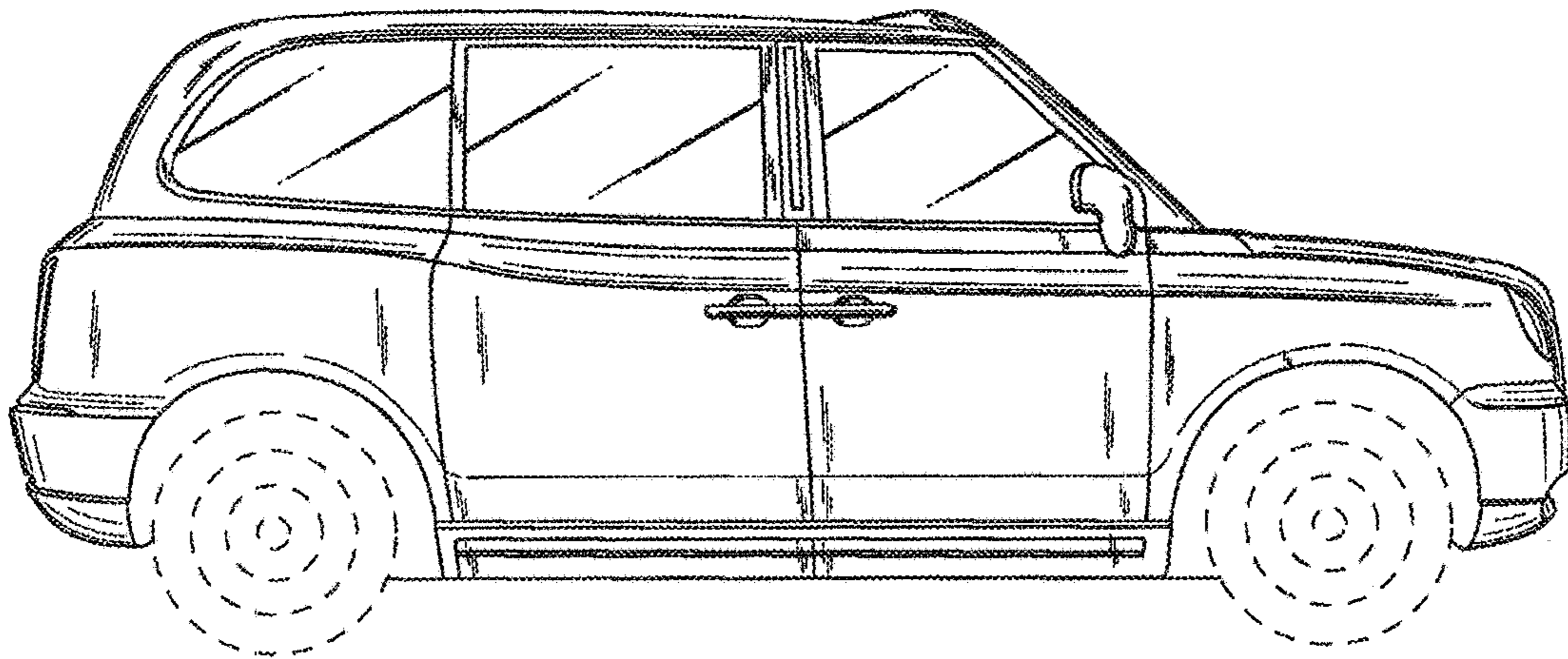

FIG. 1.5

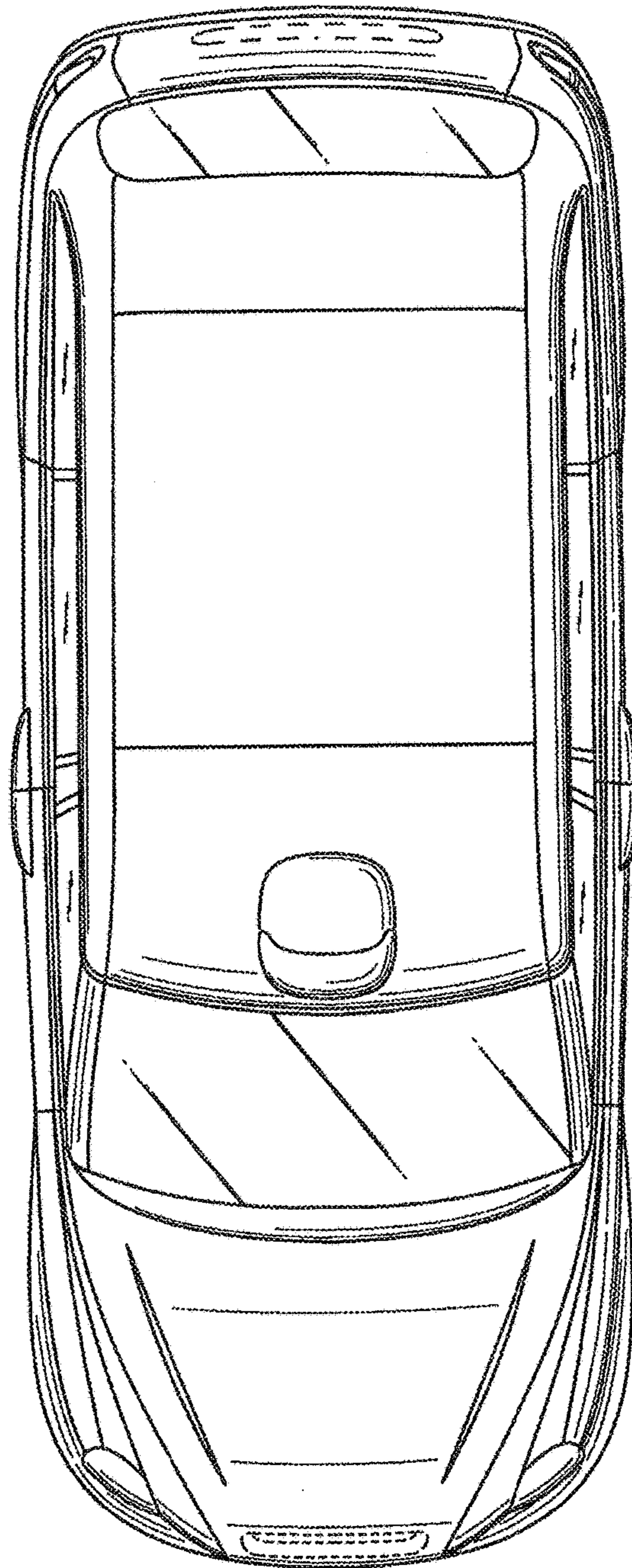

FIG. 1.6