



US00D821521S

(12) **United States Design Patent** (10) **Patent No.:** **US D821,521 S**
Peterson (45) **Date of Patent:** **** *Jun. 26, 2018**

(54) **INFLATABLE TOWABLE VEHICLE**
(71) Applicant: **SDS Asia Limited, BVI #1748971,**
Hong Kong (CN)
(72) Inventor: **Leroy L. Peterson,** Omaha, NE (US)
(73) Assignee: **SDS Asia Limited, BVI #1748971,**
Hong Kong (HK)
(*) Notice: This patent is subject to a terminal disclaimer.
(**) Term: **15 Years**

D397,755 S * 9/1998 Peterson D21/803
D407,779 S * 4/1999 Peterson D21/803
D407,783 S * 4/1999 Peterson D21/803
D407,784 S * 4/1999 Peterson D21/803
D413,956 S * 9/1999 Peterson D21/801
D414,235 S * 9/1999 Peterson D21/801
D428,090 S * 7/2000 Peterson D21/801
D428,091 S * 7/2000 Peterson D21/801
D428,092 S * 7/2000 Peterson D21/801
D428,093 S * 7/2000 Peterson D21/801
D428,096 S * 7/2000 Peterson D21/801
D428,099 S * 7/2000 Peterson D21/801
D428,464 S * 7/2000 Peterson D21/801
D428,465 S * 7/2000 Peterson D21/801

(Continued)

(21) Appl. No.: **29/545,603**
(22) Filed: **Nov. 13, 2015**
(51) **LOC (11) Cl.** **21-02**
(52) **U.S. Cl.**
USPC **D21/803**
(58) **Field of Classification Search**
USPC D21/800–803, 809–810, 424, 451, 473,
D21/814, 818–819, 828–830; D6/596,
D6/601, 604–605, 621, 362–363,
D6/379–380, 386; D12/316;
114/345–346; 441/35, 40, 66, 129–130;
472/128–129
CPC .. Y10S 5/945; A63G 1/12; A63G 3/00; A63G
21/00; A63G 21/04; A63G 21/18; A63G
25/00; A47C 1/14; A47C 1/143; A47C
3/023; A47C 5/06; A47C 7/022; B63C
2009/0023; B63C 2009/042; B63C 9/30;
B63C 7/00
See application file for complete search history.

(56) **References Cited**
U.S. PATENT DOCUMENTS
D330,578 S * 10/1992 Cochran D21/803
D347,873 S * 6/1994 Lohn D21/803
D351,009 S * 9/1994 Wolfe D12/316
D366,161 S * 1/1996 Arcouette D21/809
D384,721 S * 10/1997 Peterson D21/809

OTHER PUBLICATIONS
“WOW world of watersports, 15-1040, 3P coupe cockpit, ergo-
nomic cockpit seating, 1 to 3 person,” [online], posted Aug. 15,
2016, retrieved Dec. 5, 2016, retrieved from <https://www.amazon.com/WOW-Watersports-15-1040-Cockpit-Ergonomic/dp/B00R75OFYS/ref=sr_1_2?ie=UTF8&qid=1480963499&sr=8-2&keywords=wow+coupe+cockpit>.*

Primary Examiner — Shannon W Morgan
(74) *Attorney, Agent, or Firm* — Suiter Swantz pc llo

(57) **CLAIM**
The ornamental design for an inflatable towable vehicle, as shown and described.

DESCRIPTION
FIG. 1 is a perspective view showing my new design;
FIG. 2 is a top plan view thereof;
FIG. 3 is a front elevation view thereof;
FIG. 4 is a left side elevation view thereof;
FIG. 5 is a right side elevation view thereof;
FIG. 6 is a rear elevation view thereof; and,
FIG. 7 is a bottom plan view thereof.
The broken lines illustrate stitching and portions of the inflatable towable vehicle. None of the broken lines form part of the claimed design.

1 Claim, 3 Drawing Sheets

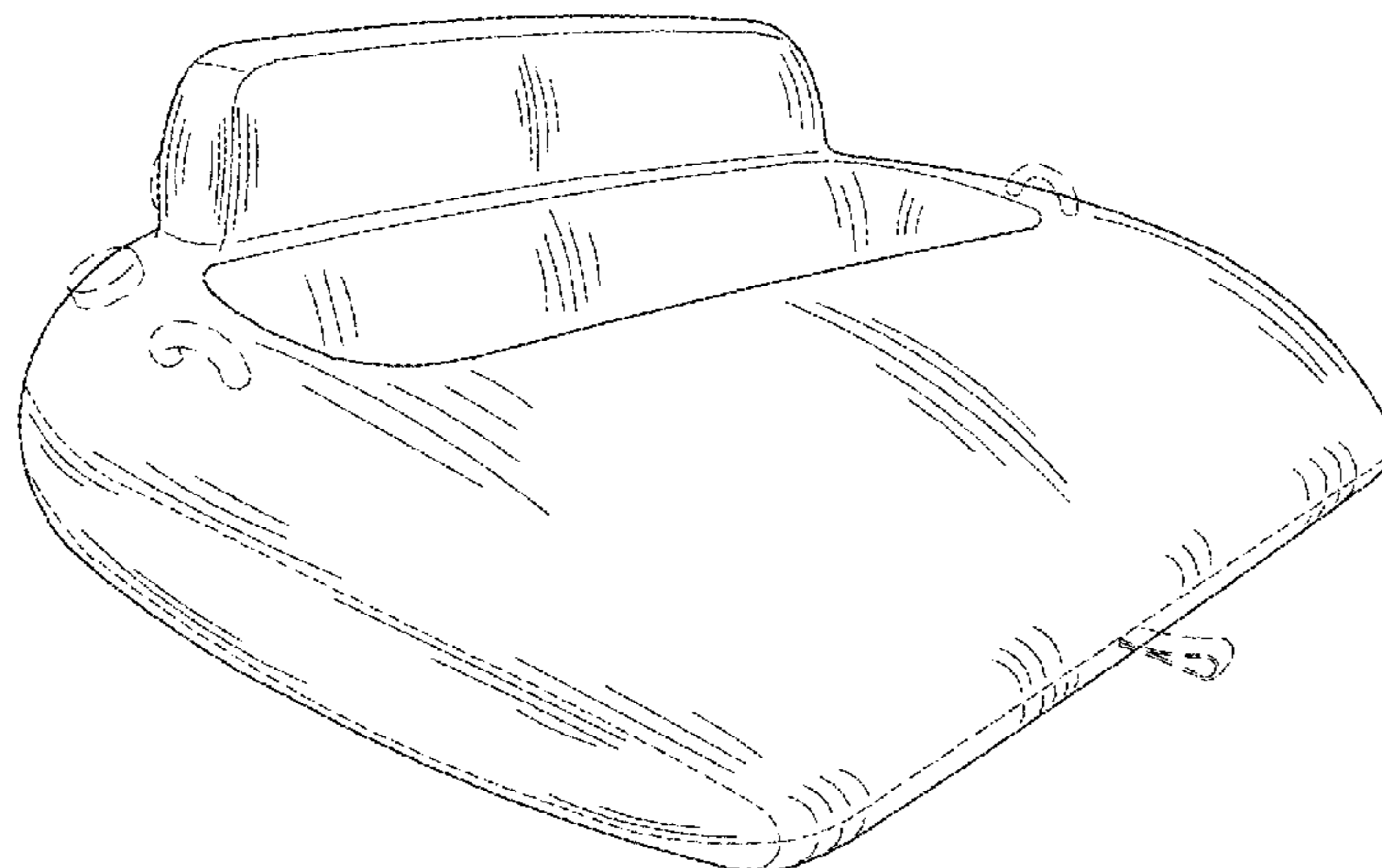

(56)

References Cited

U.S. PATENT DOCUMENTS

D432,199	S	*	10/2000	Peterson	D12/316
D435,239	S	*	12/2000	Peterson	D12/316
D435,240	S	*	12/2000	Peterson	D12/316
D435,504	S	*	12/2000	Peterson	D12/316
D435,505	S	*	12/2000	Peterson	D12/316
D435,506	S	*	12/2000	Peterson	D12/316
D435,507	S	*	12/2000	Peterson	D12/316
D435,508	S	*	12/2000	Peterson	D12/316
D437,283	S	*	2/2001	Peterson	D12/316
D437,379	S	*	2/2001	Peterson	D21/801
D465,540	S	*	11/2002	Peterson	D21/803
D485,593	S	*	1/2004	Muci	D21/769
D554,727	S	*	11/2007	Peterson	D21/803
8,657,640	B2	*	2/2014	Le Gette	A47C 15/006 441/131
D702,789	S	*	4/2014	Berenson	D21/803
D719,630	S	*	12/2014	Berenson	D21/803
D765,200	S	*	8/2016	Gershon	D21/803
D765,203	S	*	8/2016	Peterson	D21/803
D794,738	S	*	8/2017	Peterson	D21/803
D803,965	S	*	11/2017	Peterson	D21/803

* cited by examiner

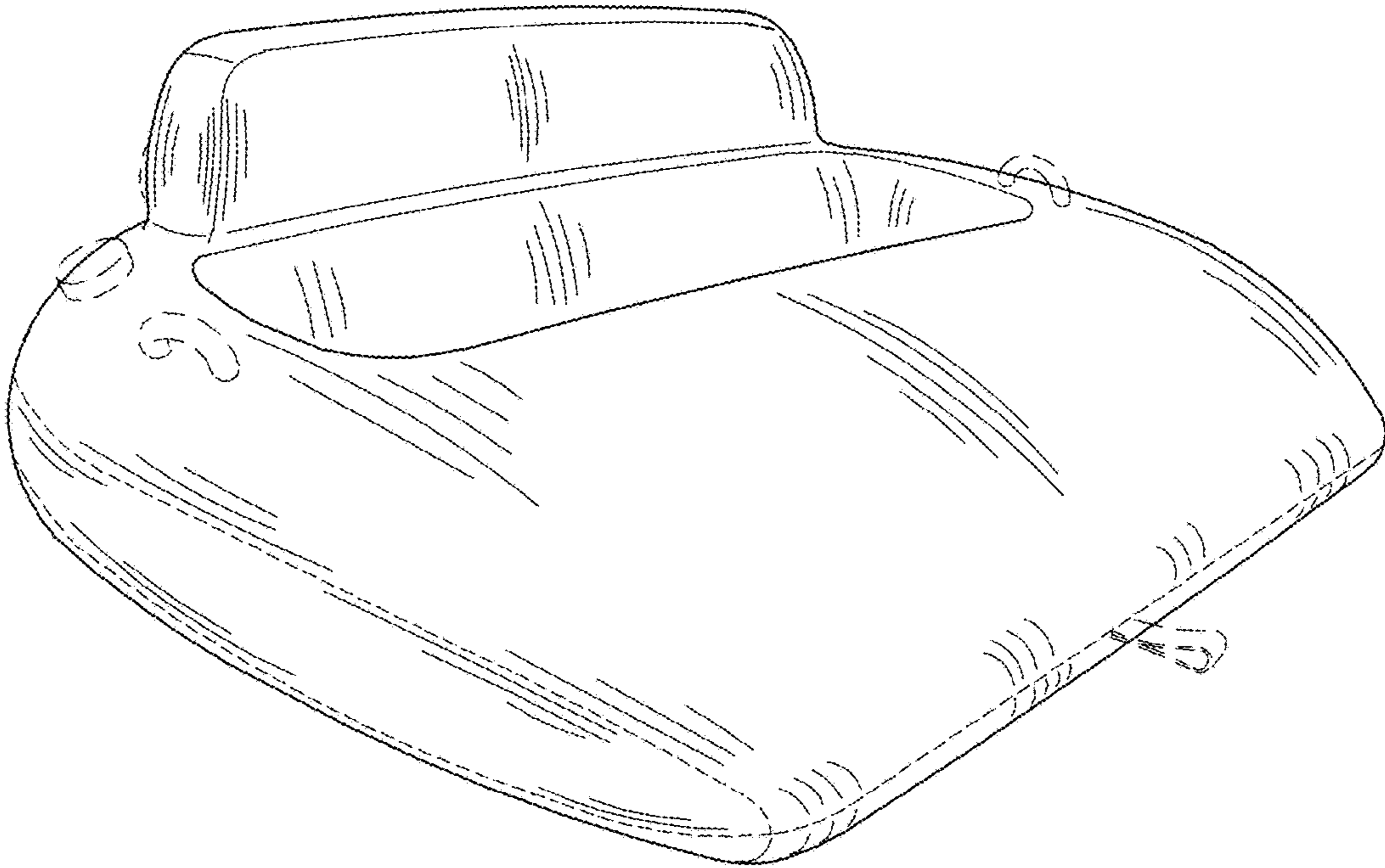

FIG. 1

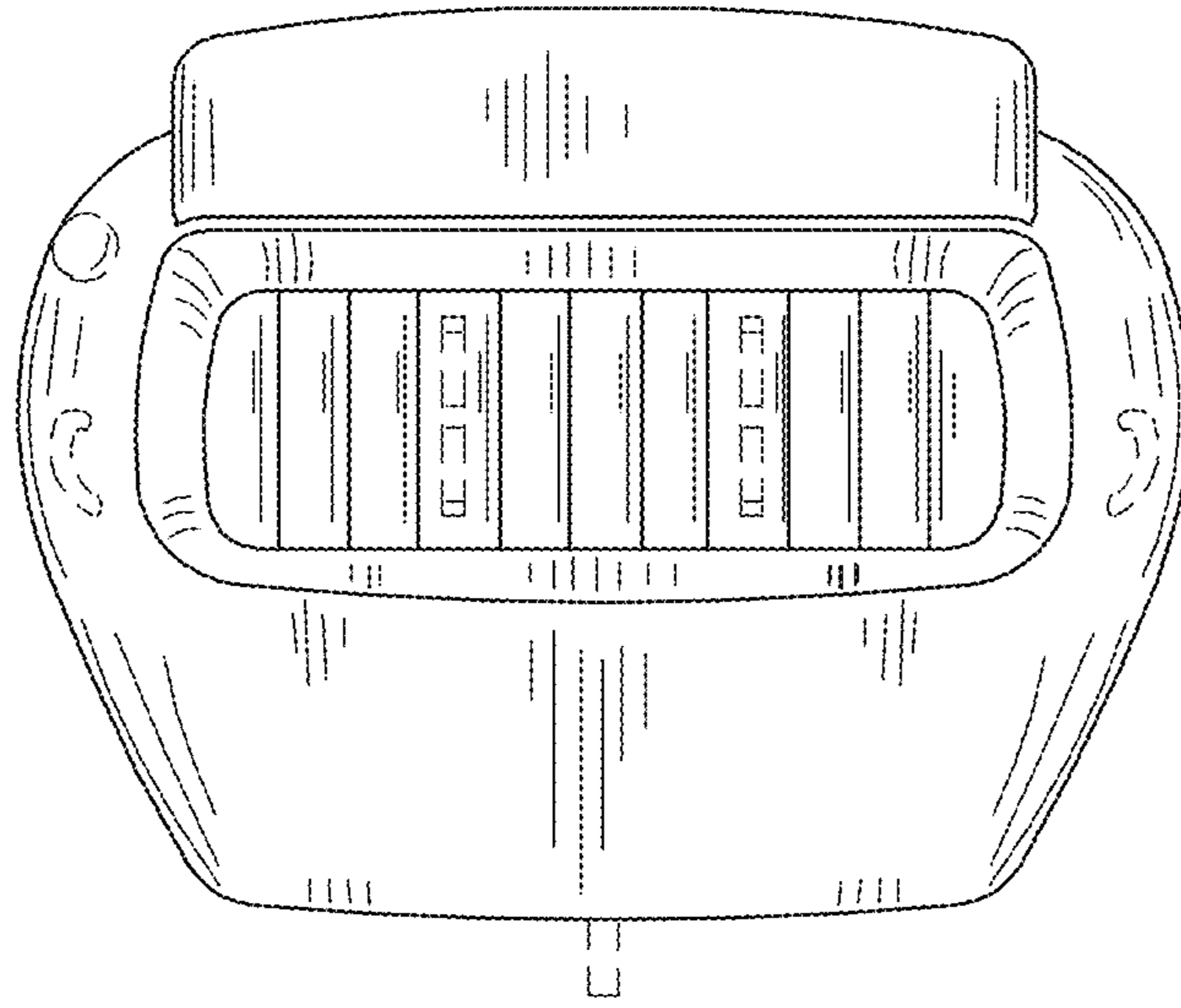

FIG. 2

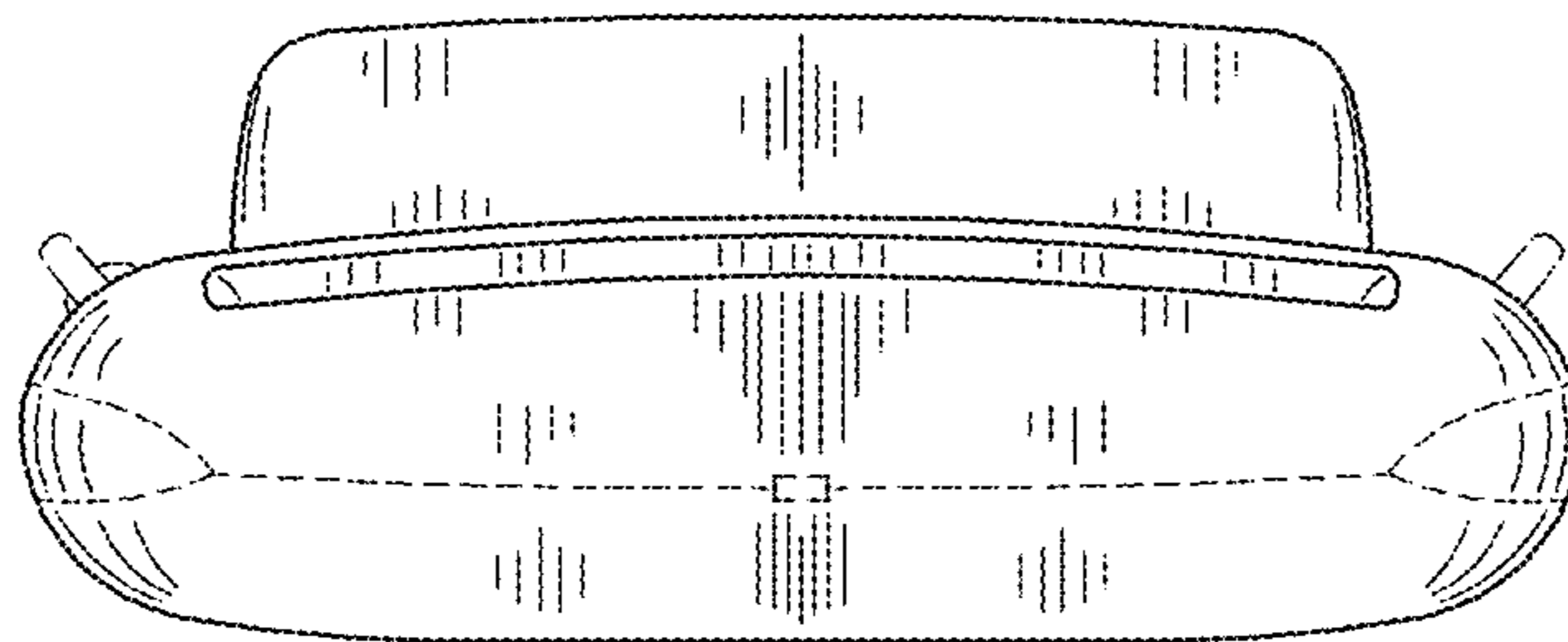

FIG. 3



FIG. 4

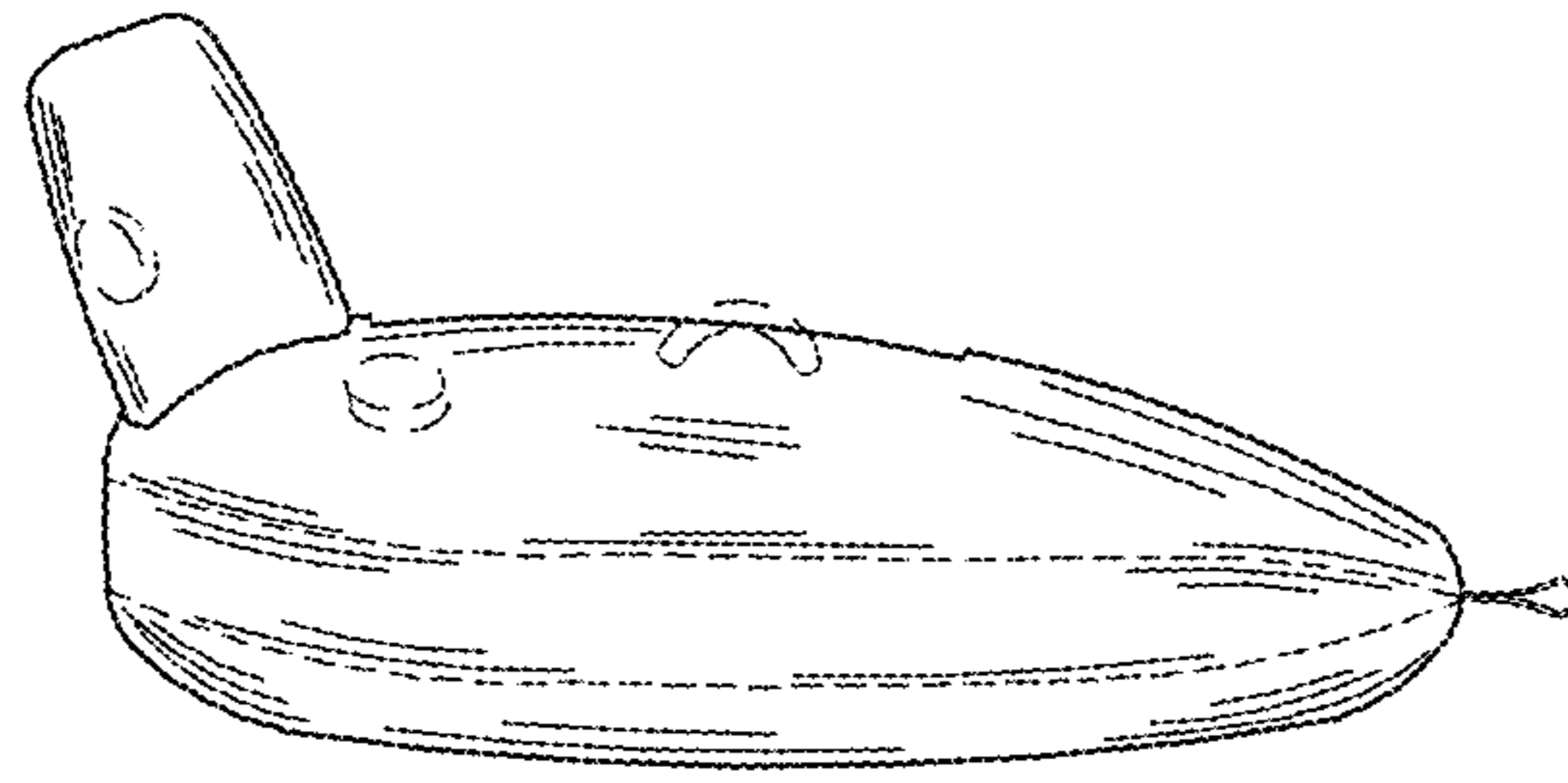

FIG. 5

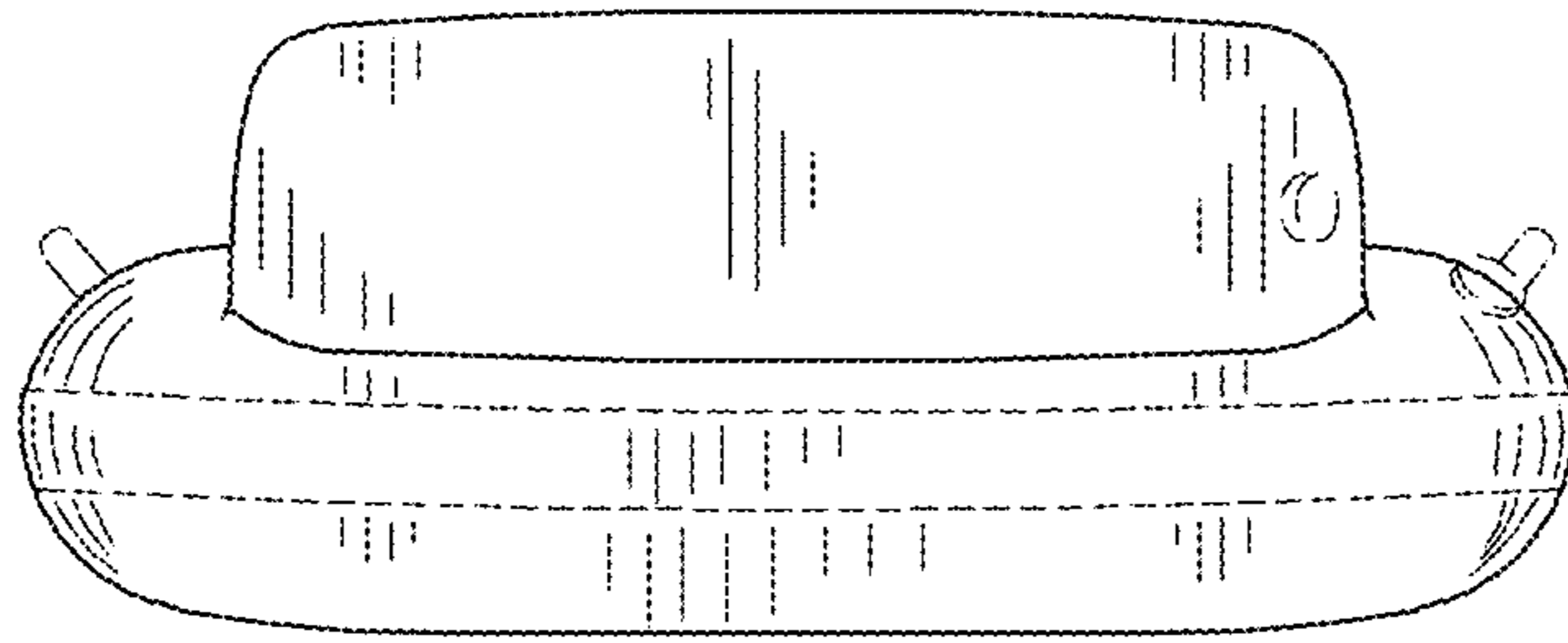

FIG. 6

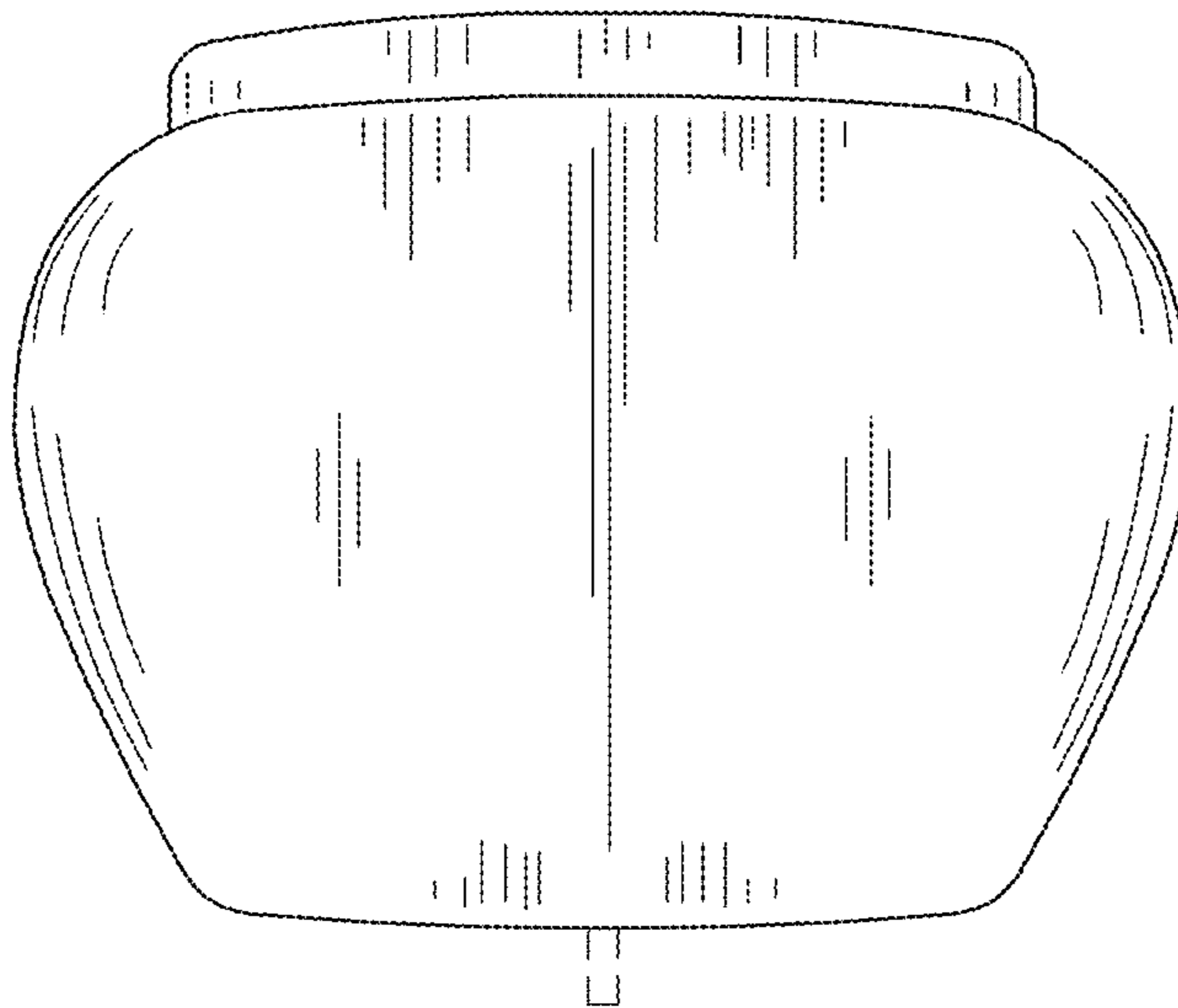

FIG. 7