



US00D821316S

(12) **United States Design Patent** (10) **Patent No.:** **US D821,316 S**
Yang (45) **Date of Patent:** **** Jun. 26, 2018**

(54) **ROTOR FOR A WAVE ENERGY CONVERTER**
(71) Applicant: **Yingchen Yang**, Edinburg, TX (US)
(72) Inventor: **Yingchen Yang**, Edinburg, TX (US)
(73) Assignee: **THE BOARD OF REGENTS OF THE UNIVERSITY OF TEXAS SYSTEM**, Austin, TX (US)

D200,964 S * 4/1965 Phelps D21/458
3,604,942 A * 9/1971 Nelson F03B 17/065
290/54
4,313,711 A 2/1982 Lee 415/7
8,100,650 B2 1/2012 Siegel 416/53
8,206,113 B2 6/2012 Ryyanen et al. 416/176
8,664,790 B2* 3/2014 Cornelius F03B 3/04
290/54

(Continued)

(**) Term: **15 Years**
(21) Appl. No.: **29/585,778**
(22) Filed: **Nov. 29, 2016**

FOREIGN PATENT DOCUMENTS

WO WO/00/017519 3/2000
WO WO/06/100436 9/2006

(Continued)

OTHER PUBLICATIONS

Faizal et al, 2009, Renewable Energy, 35, 164-169.

(Continued)

Related U.S. Application Data

(63) Continuation-in-part of application No. PCT/US2016/052837, filed on Sep. 21, 2016.
(51) **LOC (11) Cl.** **13-01**
(52) **U.S. Cl.**
USPC **D13/114**; D13/115
(58) **Field of Classification Search**
USPC D12/180; D13/101, 102, 103, 107, 112, D13/114, 115, 116, 118, 122, 125, 133, D13/162.1, 184, 199; D14/188; D21/405, 409, 424, 450, 458, 463, 510, D21/578, 585; D23/315, 356, 377; D25/35; D32/17, 68, 70, 71, 73
CPC ... B63J 2003/046; F03B 13/18; F03B 13/141; F03B 13/1825; F03B 13/183; F03B 13/186; F03B 13/12; F03B 13/1885; F03B 13/20; F03B 17/061; F05B 2240/243; F05B 2250/292; F05B 2250/25; Y02E 10/28; Y02E 10/38; Y02E 10/725
See application file for complete search history.

Primary Examiner — Mary Ann Calabrese
Assistant Examiner — Catherine Ho
(74) *Attorney, Agent, or Firm* — Norton Rose Fulbright US LLP

(57) **CLAIM**

The ornamental design for a rotor for a wave energy converter, as shown and described.

DESCRIPTION

FIG. 1 is a perspective view of a rotor for a wave energy converter, showing my new design;
FIG. 2 is a top plan view thereof;
FIG. 3 is a bottom plan view thereof;
FIG. 4 is a right side elevational view thereof;
FIG. 5 is a left side elevational view thereof;
FIG. 6 is a front elevational view thereof; and,
FIG. 7 is a back elevational view thereof.

(56) **References Cited**
U.S. PATENT DOCUMENTS

D125,274 S * 2/1941 Kiefer D21/458
D197,269 S * 1/1964 Lewis D20/21

1 Claim, 7 Drawing Sheets

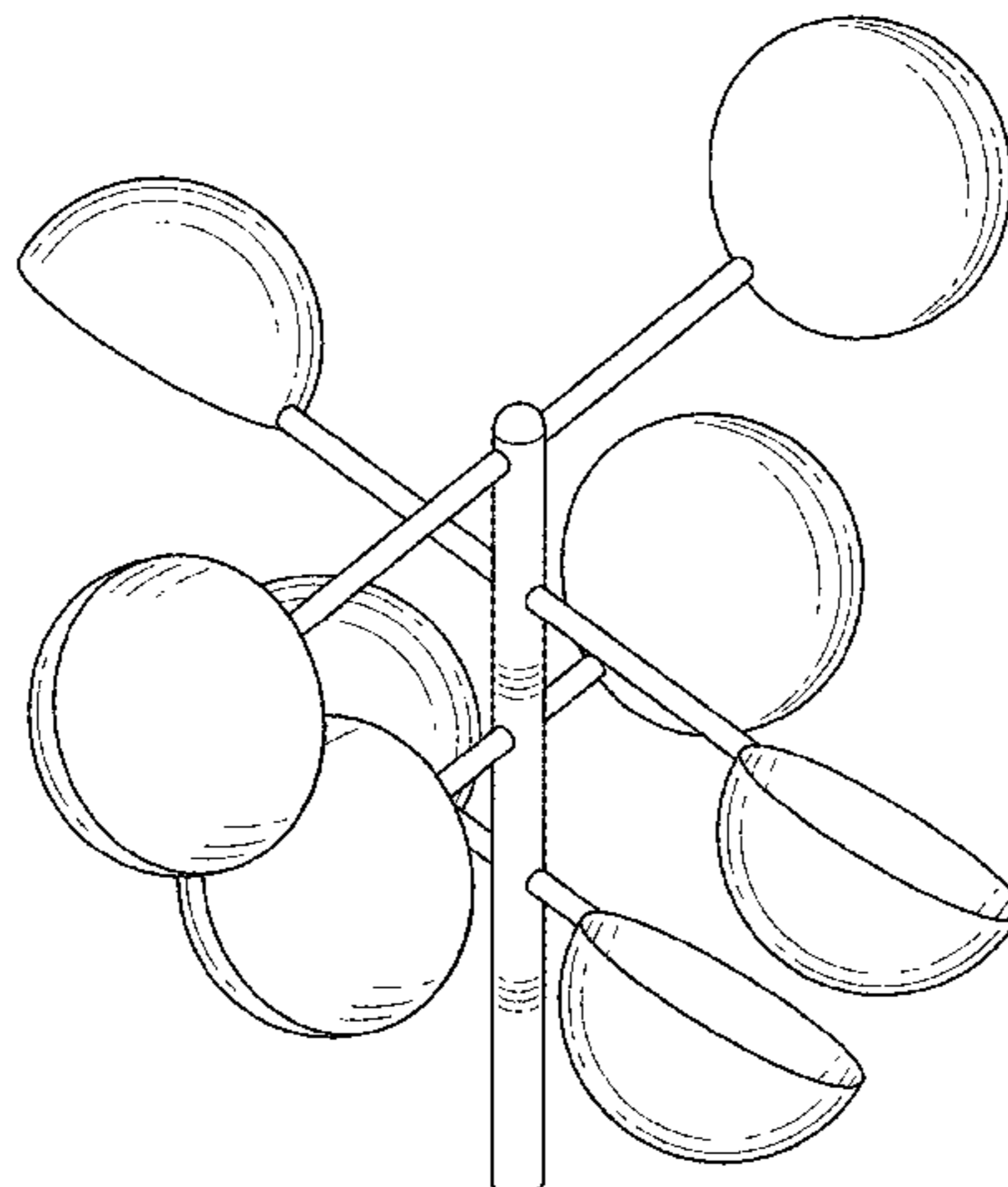

(56)

References Cited

U.S. PATENT DOCUMENTS

D778,774 S * 2/2017 Weiser D11/162
2009/0211241 A1 8/2009 Moffat 60/501
2010/0320766 A1 12/2010 Klukowski 290/53
2011/0123332 A1* 5/2011 Grenier F03D 3/061
416/41
2011/0262280 A1* 10/2011 Schubert B29C 70/30
416/223 R
2014/0327338 A1 11/2014 Vamvas 310/306

FOREIGN PATENT DOCUMENTS

WO WO/07/130334 11/2007
WO WO/10/011133 1/2010
WO WO/12/166063 12/2012

OTHER PUBLICATIONS

International Search Report and Written Opinion in International
Application No. PCT/US2016/052837 dated Dec. 12, 2016.
Mohamed, *Energy*, 47:522-30, 2012.
Pierson and Moskowitz, *Journal of Geophysical Research*,
69:5181-90, 1964.
Pindado et al., *The Scientific World Journal*, Article ID 197325,
2013.
Raghunathan, *Progress in Aerospace Sciences*, 31:335-386, 1995.

* cited by examiner

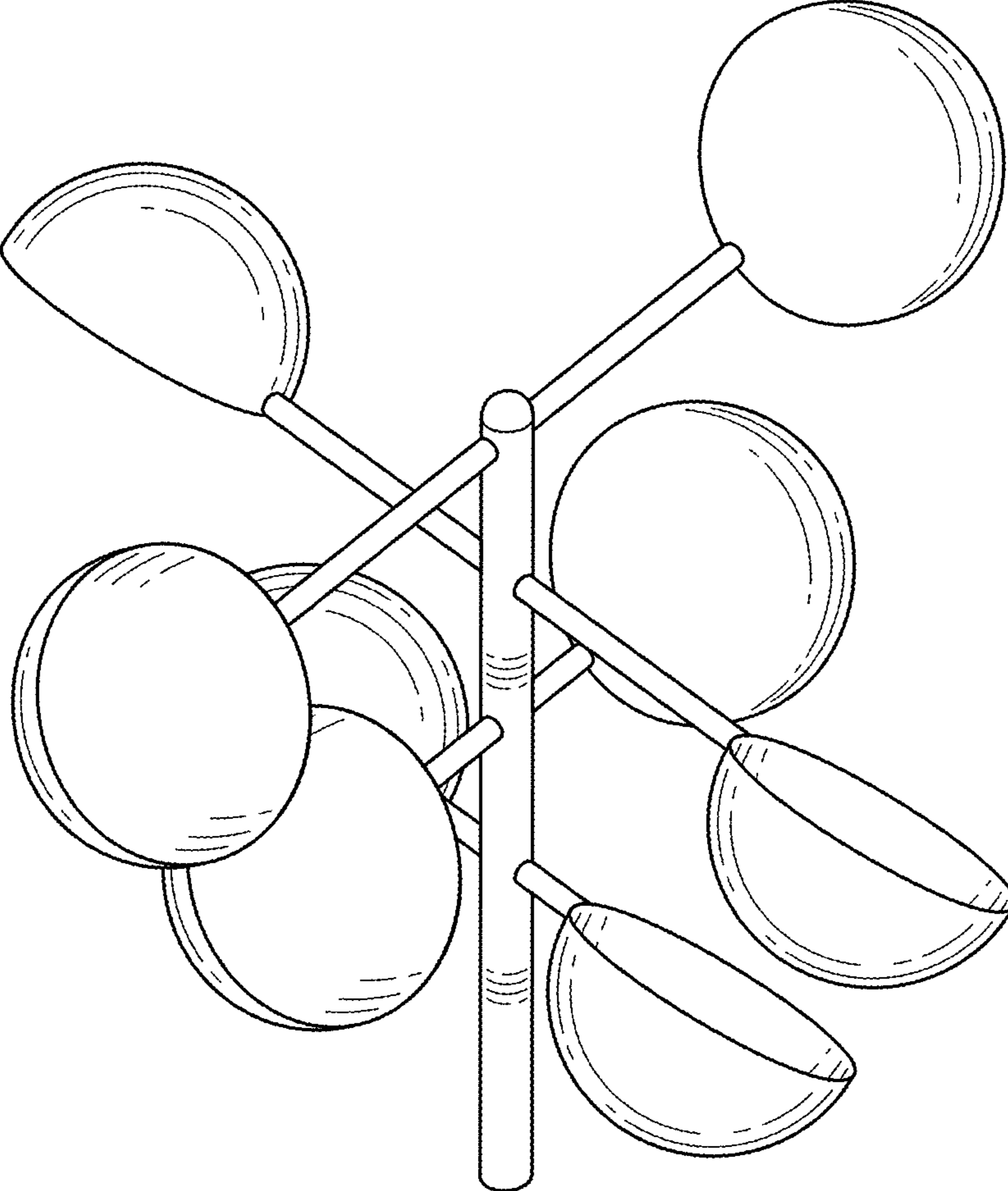

FIG. 1

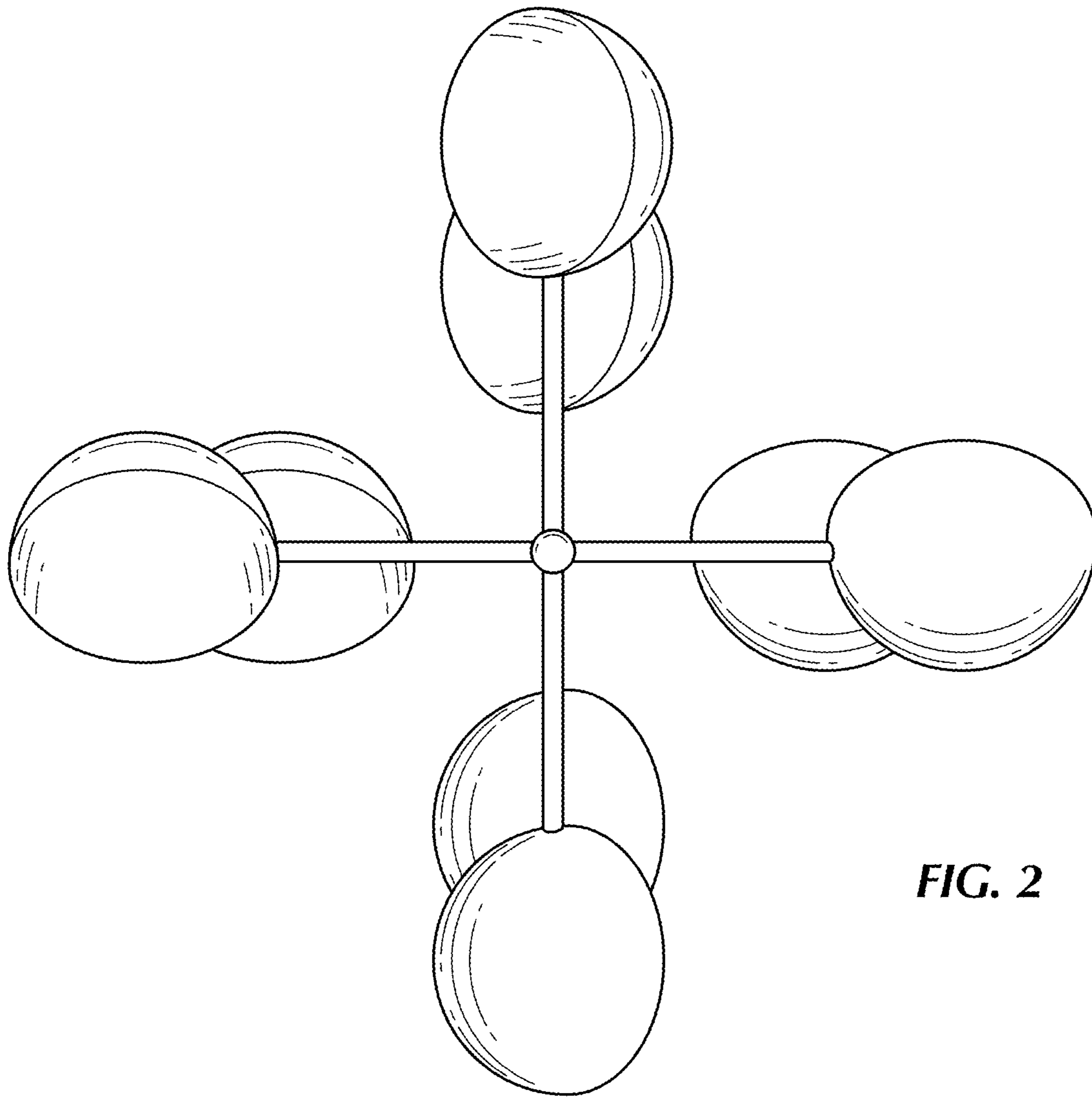

FIG. 2

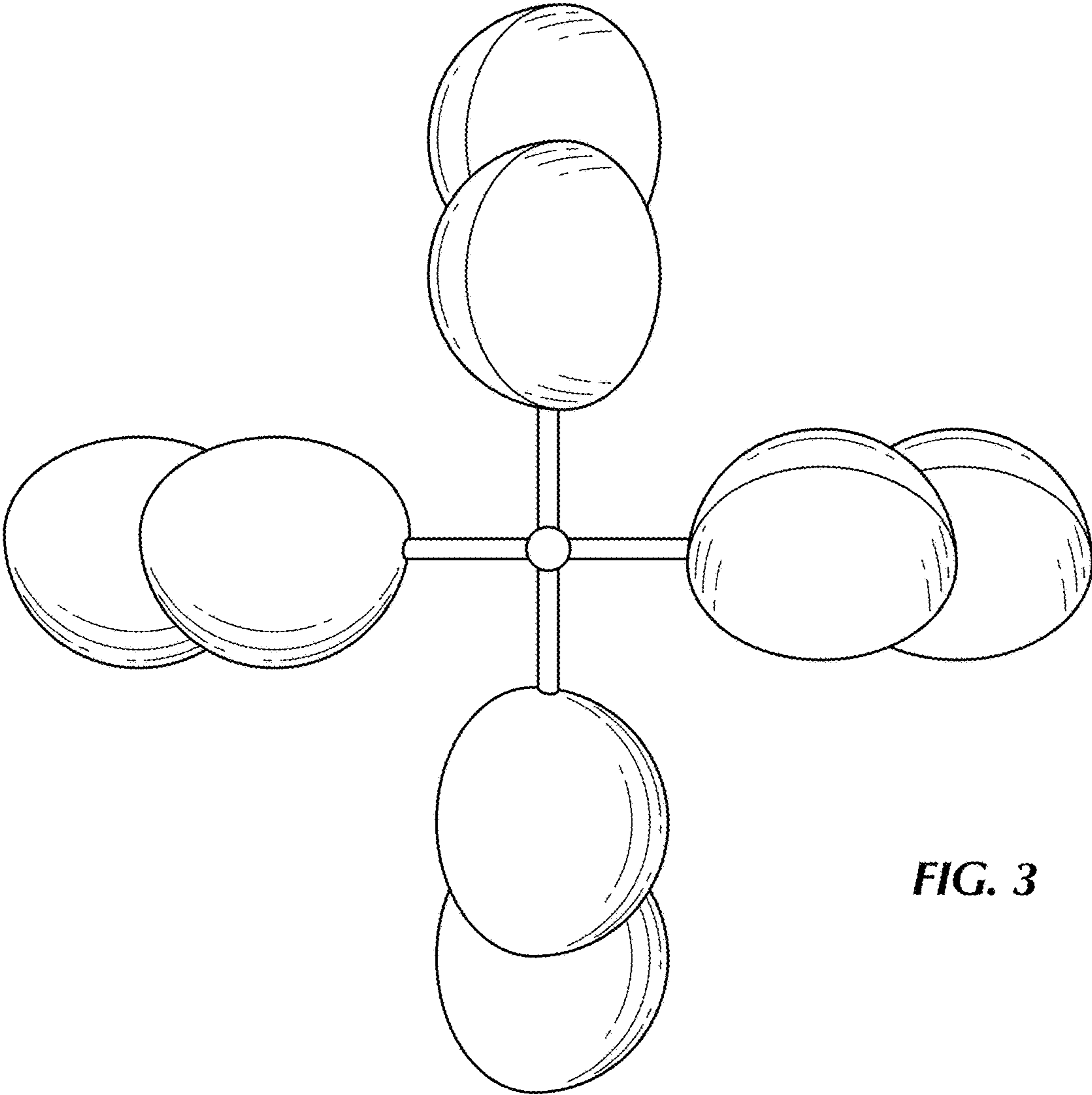

FIG. 3

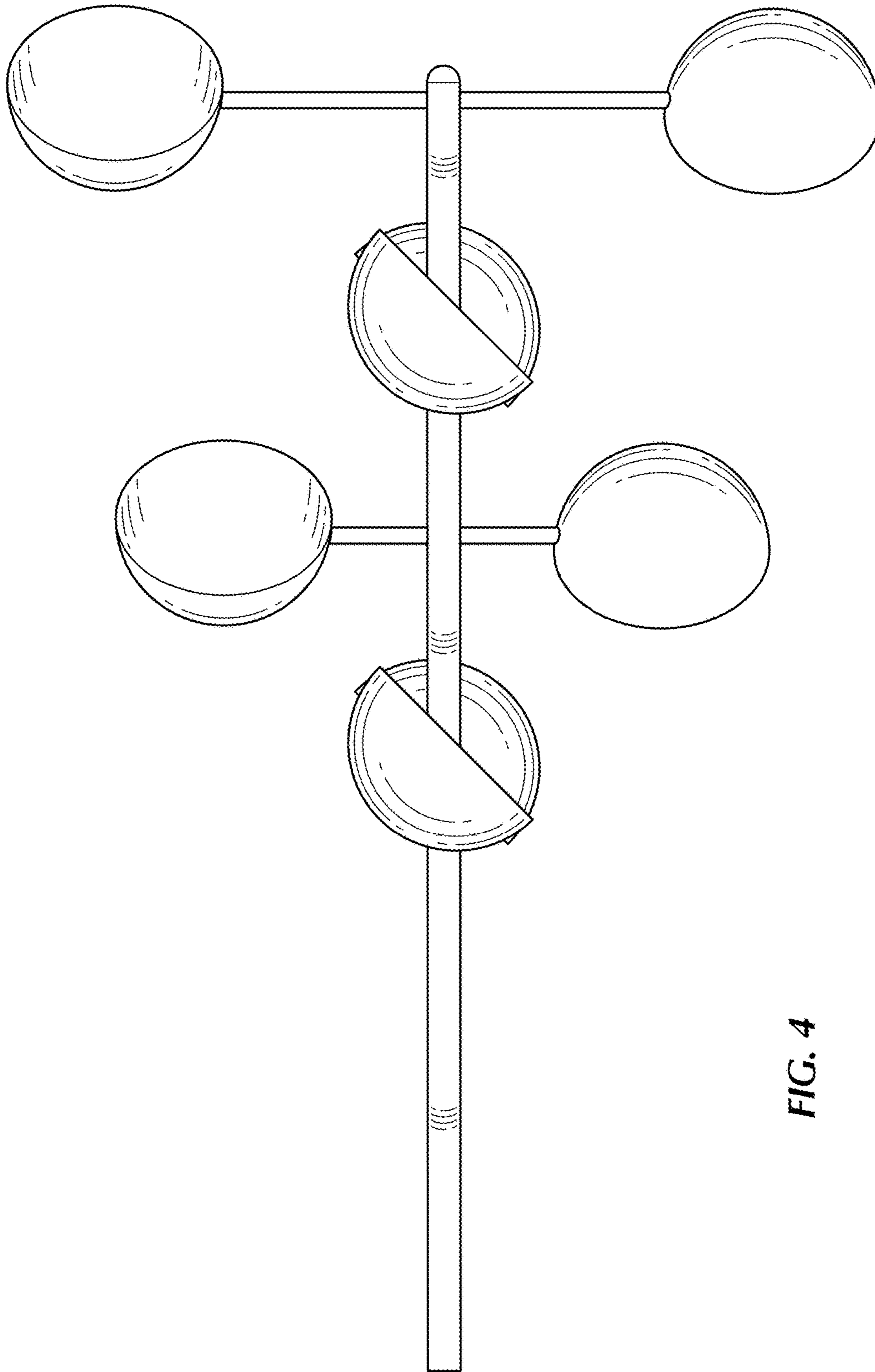

FIG. 4

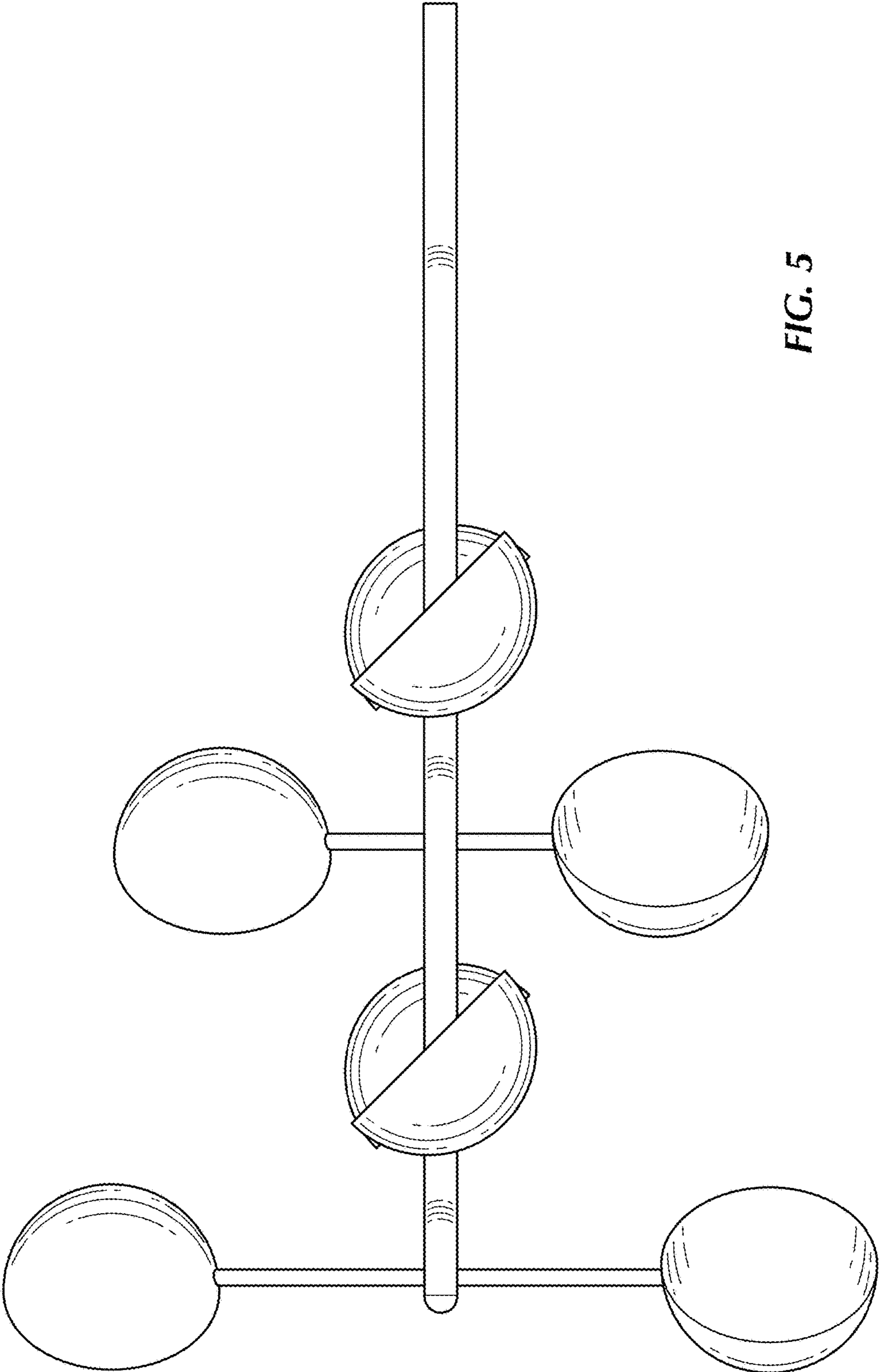

FIG. 5

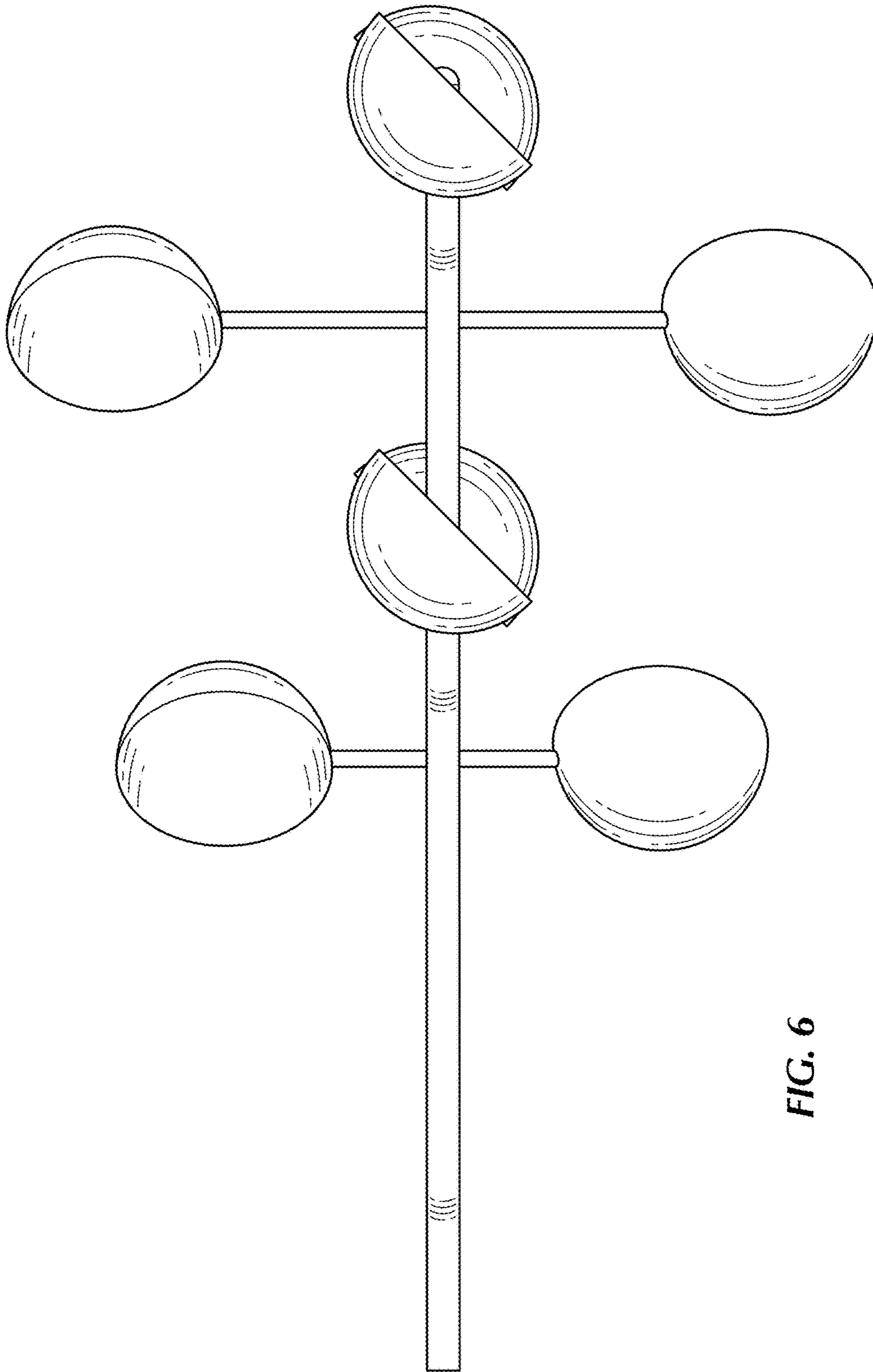

FIG. 6

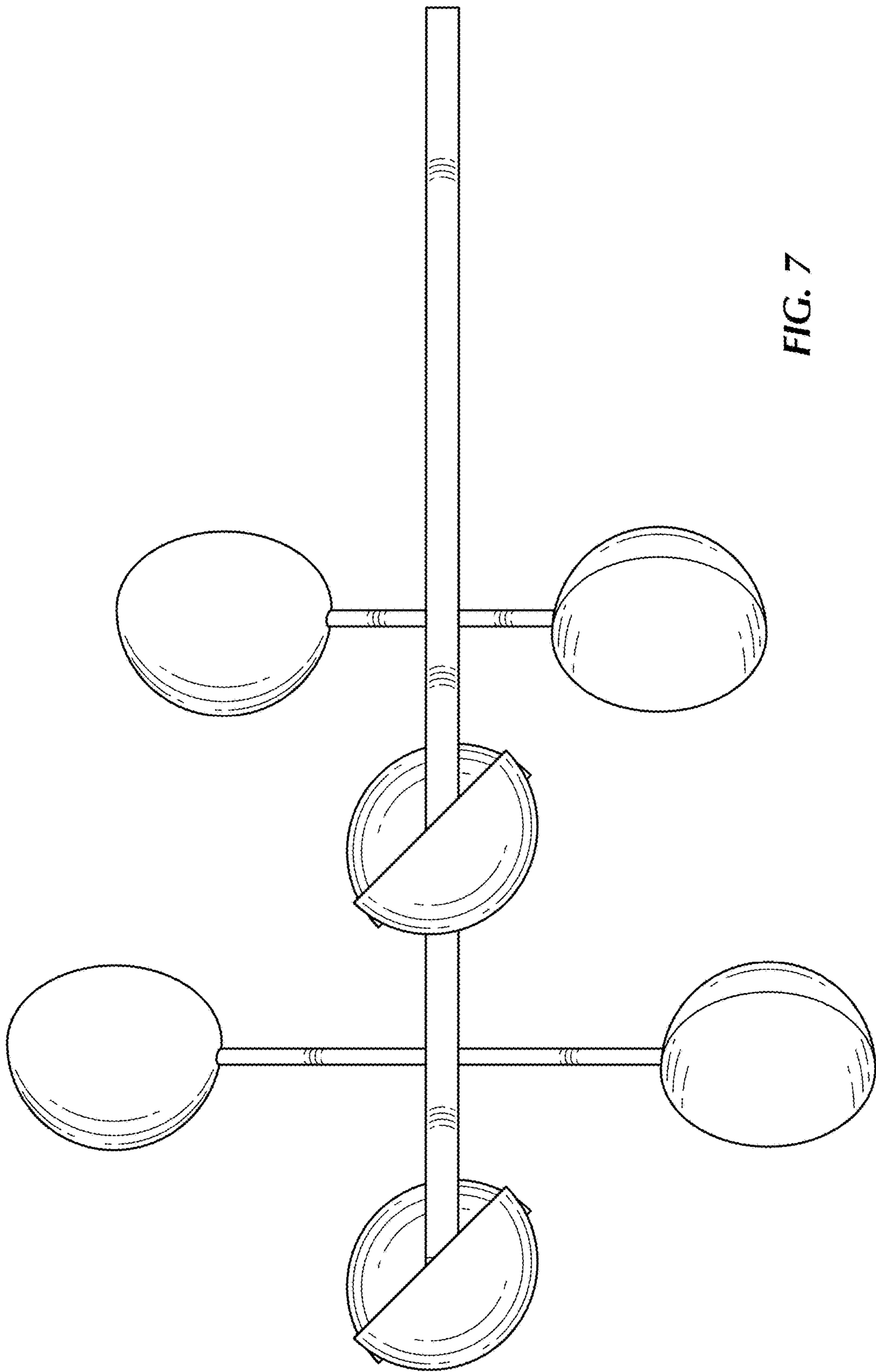

FIG. 7