



US00D820875S

(12) **United States Design Patent** (10) **Patent No.:** **US D820,875 S**
Endreß et al. (45) **Date of Patent:** **** Jun. 19, 2018**

(54) **DISPLAY SCREEN OR PORTION THEREOF WITH GRAPHICAL USER INTERFACE**

(71) Applicant: **Airbus Operations GmbH**, Hamburg (DE)

(72) Inventors: **Manfred Endreß**, Hamburg (DE);
Holger Kuhlmann, Hamburg (DE);
Kai Möller, Hamburg (DE);
Jörn-Oliver Krumsieg, Hamburg (DE)

(73) Assignee: **AIRBUS OPERATIONS GMBH**, Hamburg (DE)

(**) Term: **15 Years**

(21) Appl. No.: **29/605,218**

(22) Filed: **May 24, 2017**

(30) **Foreign Application Priority Data**

Nov. 25, 2016 (EM) 003482801-0001

(51) **LOC (11) Cl.** **14-04**

(52) **U.S. Cl.**
USPC **D14/486**; D14/492

(58) **Field of Classification Search**
USPC D14/485-495; D20/10, 11, 22-33, 39,
D20/40; D5/20, 26, 30, 40, 63-65
CPC G06F 3/048-3/04897; G06F 3/017; G01C
23/00; G01C 23/005; A63F 2300/308;
G08G 5/0021; G08G 5/0047; G08G 5/04;
G02B 27/01; G06Q 10/00

See application file for complete search history.

(56) **References Cited**

U.S. PATENT DOCUMENTS

5,467,943 A * 11/1995 Umeda B32B 17/10018
114/173
7,437,005 B2 * 10/2008 Drucker G06F 3/0483
382/205

D590,415 S * 4/2009 Ball D14/486
7,661,075 B2 * 2/2010 Lahdesmaki G06F 3/0482
715/821
D714,323 S * 9/2014 Pereira D14/485
D738,910 S * 9/2015 Drozd D14/488
D757,041 S * 5/2016 Zankowski D14/485
D765,717 S * 9/2016 Cho D14/487
D790,562 S * 6/2017 Nageli D14/485
D800,759 S * 10/2017 Perekoty D14/486
D804,495 S * 12/2017 Kim D14/485
D807,392 S * 1/2018 Lindmark D14/488

(Continued)

FOREIGN PATENT DOCUMENTS

EM 004 014 900-0001 5/2017

OTHER PUBLICATIONS

Close-Up of an Aircraft Cabin Door, by Mann, dreamstime.com [online], published on Jul. 15, 2016, [retrieved on Jan. 31, 2018], retrieved from the Internet <URL: <https://www.dreamstime.com/stock-photo-aircraft-cabin-door-close-up-image74955593>>.*

(Continued)

Primary Examiner — Cathron C Brooks

Assistant Examiner — Ian F Whitmore

(74) *Attorney, Agent, or Firm* — Greer, Burns & Crain, Ltd.

(57) **CLAIM**

The ornamental design for a display screen or portion thereof with graphical user interface, as shown and described.

DESCRIPTION

The FIGURE is a front view of a display screen or portion thereof with graphical user interface showing our new design;

The broken-line perimeter illustrates a display screen or portion thereof and forms no part of the claimed design.

1 Claim, 1 Drawing Sheet

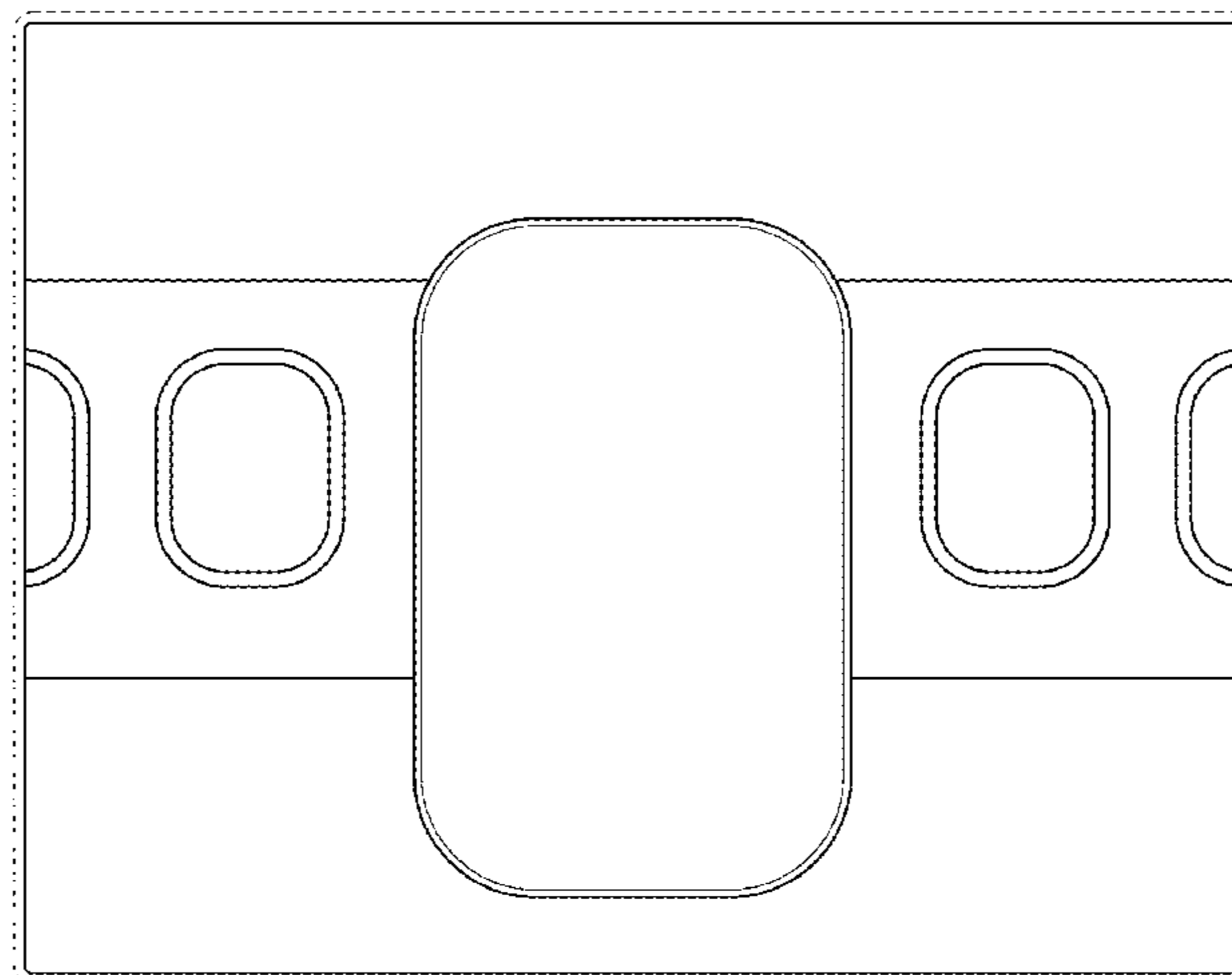

(56)

References Cited

U.S. PATENT DOCUMENTS

2017/0344181 A1* 11/2017 Kneuper G08G 5/0034

OTHER PUBLICATIONS

Plane Doors Can't Open During the Flight, [asaptickets.com](https://blog.asaptickets.com) [online], published on Jun. 22, 2016, [retrieved on Jan. 31, 2018], retrieved from the Internet <URL: <https://blog.asaptickets.com/tips/how-to-overcome-fear-flying/>>.*

* cited by examiner

