



US00D820643S

(12) **United States Design Patent** (10) **Patent No.:** **US D820,643 S**
Mitchell et al. (45) **Date of Patent:** **** Jun. 19, 2018**

(54) **FOOD DISPENSER**

FOREIGN PATENT DOCUMENTS

(71) Applicant: **Gehl Foods, LLC**, Germantown, WI (US)

EM 000574843-0003 8/2006
EP 0 150 144 7/1985

(Continued)

(72) Inventors: **Thomas Mitchell**, Chicago, IL (US);
Anders Olof Rostlund, Chicago, IL (US); **David Mucci**, Chicago, IL (US)

OTHER PUBLICATIONS

(73) Assignee: **Gehl Foods, LLC**, Germantown, WI (US)

Alibaba. 3-way Ball Valve. 2016. Available from Internet, https://www.alibaba.com/productdetail/10000psi-cng-dispenser-3-way-ball_1797382372.html.

(Continued)

(**) Term: **15 Years**

Primary Examiner — Shannon W Morgan

(21) Appl. No.: **29/607,605**

(74) *Attorney, Agent, or Firm* — Foley & Lardner LLP

(22) Filed: **Jun. 14, 2017**

(57) **CLAIM**

We claim the ornamental design for a food dispenser, as shown and described.

Related U.S. Application Data

DESCRIPTION

(62) Division of application No. 29/501,025, filed on Aug. 29, 2014, now Pat. No. Des. 792,164.

(51) **LOC (11) Cl.** **07-07**

(52) **U.S. Cl.**
USPC **D7/589**

(58) **Field of Classification Search**
USPC D7/594, 590, 591, 592, 593, 595, 596,
D7/597, 598, 599, 600, 300, 300.1, 300.2,
D7/301, 302, 303, 304, 305, 312, 316,
D7/317, 318, 319, 321, 322, 589, 601,
D7/602, 613, 702, 703, 628, 629, 637,
D7/638, 639, 368, 669, 309, 310, 311,
D7/314, 320, 608; D9/600, 716, 719,
(Continued)

FIG. 1 is a top, front, right perspective view a food dispenser showing the new design;
FIG. 2 is a front elevation view thereof;
FIG. 3 is a rear elevation view thereof;
FIG. 4 is a right elevation view thereof;
FIG. 5 is a left elevation view thereof;
FIG. 6 is a top plan view thereof; and,
FIG. 7 is a bottom plan view thereof.

The long dash, short dash broken lines (i.e., dash-dot) define bounds of the claimed design and form no part of the claimed design. The food dispenser is shown broken in places along the height and length directions in FIGS. 1-7 to indicate indeterminate length, with the understanding that the “indeterminate” length portion of the food dispenser not shown forms no part of the claimed design. Patentability is based only on those portions of the article that are shown in solid lines. The remaining broken lines in the figures depict portions of the food dispenser that form no part of the claimed design.

(56) **References Cited**

U.S. PATENT DOCUMENTS

1,006,623 A 10/1911 Barrett
D50,625 S 4/1917 Lund

(Continued)

1 Claim, 5 Drawing Sheets

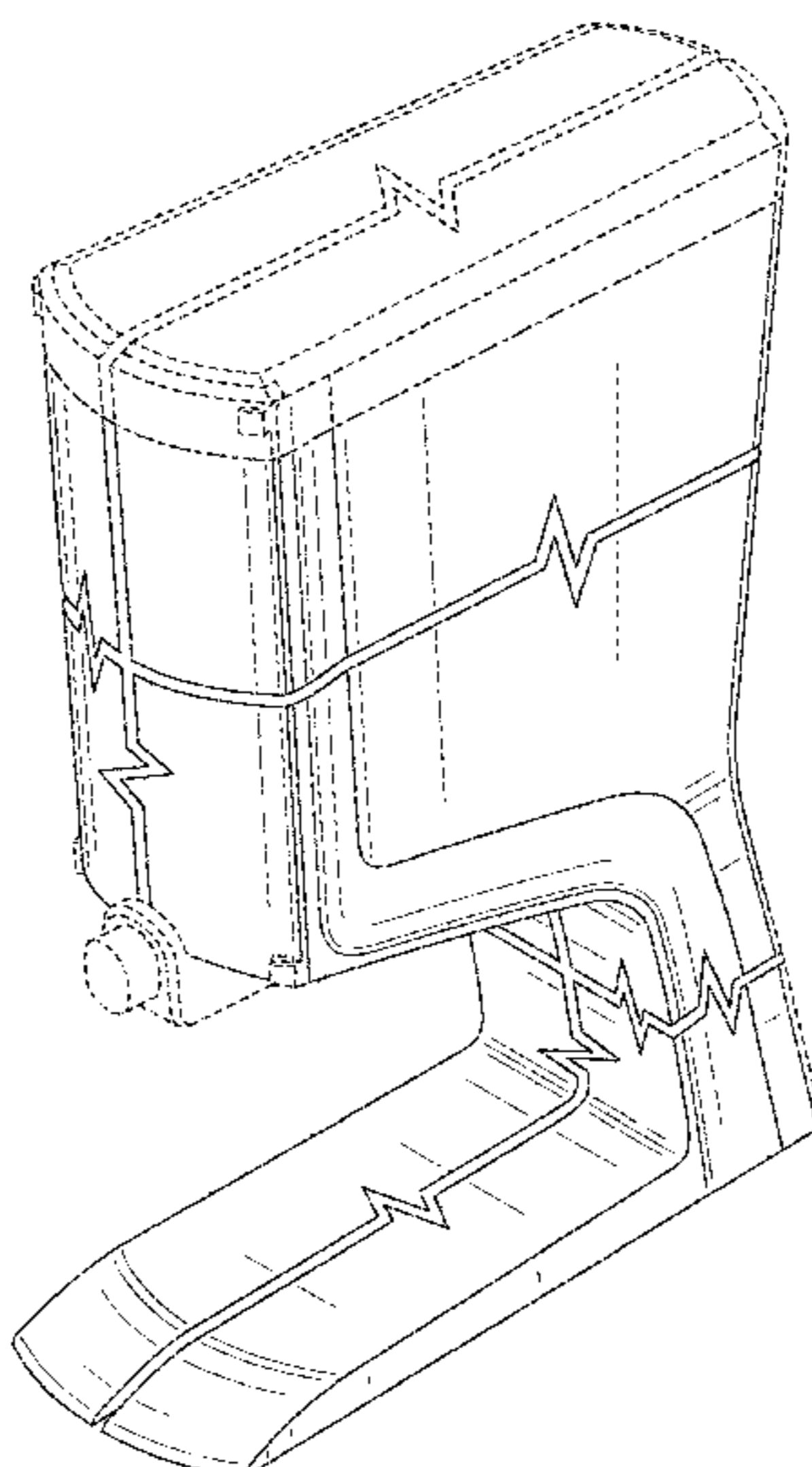

US D820,643 S

(58) **Field of Classification Search**

USPC D9/503, 505, 504, 439, 443, 454, 446, D9/436, 447, 440, 448, 449, 450, 451, D9/452, 453, 455; D20/1 CPC .. A47J 47/00; A47J 47/01; A47J 47/16; A47J 42/34; A47J 42/00; A47J 42/02; A47J 42/04; A47J 42/06; A47J 42/08; A47J 42/10; A47J 42/12; A47J 42/14; A47J 42/16; A47J 42/18; A47J 42/20; A47J 42/22; A47J 42/24; A47J 42/26; A47J 43/00; A47J 47/04; B65D 83/04; B65D 83/0409; B65D 83/0445; B65D 83/0418; B65D 83/0427; B65D 83/0436; B65D 83/0481; B65D 83/06; B65D 83/08; B65D 83/02; B65D 50/00; B65D 39/04; B65D 39/002; B65D 39/06; A47G 19/24; A47G 19/00; A47G 19/12; A47G 19/122; A47G 19/125; A47G 19/127; A47G 19/18; A47G 19/20; A47G 19/14; A47G 19/32; A47G 19/34; G07F 1/00; G07F 7/00; G07F 11/002; G07F 11/005; G07F 11/007; A01K 5/0114; A01K 5/01; G01F 11/24; G01F 11/125; B67D 7/0266; B67D 7/02; A47F 1/03; B65B 3/0035; A23G 9/22 See application file for complete search history.	4,322,019 A 3/1982 Smith 4,417,672 A 11/1983 Eppenbach 4,440,316 A 4/1984 Christine D277,633 S * 2/1985 McClellan D20/7 4,497,351 A 2/1985 Garcia 4,513,885 A * 4/1985 Hogan B67D 7/0205 222/105 4,515,294 A * 5/1985 Udall A47K 5/1209 222/105 D282,617 S * 2/1986 Hogan D7/308 4,602,725 A 7/1986 Malpas et al. 4,621,750 A 11/1986 Roethel D290,074 S * 6/1987 Braun D6/515 4,690,307 A 9/1987 Hogan 4,724,981 A 2/1988 Realmuto D296,405 S * 6/1988 Weaver D7/589 D297,105 S 8/1988 Hollinshead 4,776,488 A 10/1988 Gurzan 4,795,062 A 1/1989 Bedwell et al. 4,846,236 A 7/1989 Deruntz 4,856,681 A 8/1989 Murray 4,913,713 A * 4/1990 Bender B67D 1/06 222/146.6 4,925,034 A 5/1990 Robichaud et al. 4,946,040 A 8/1990 Ipenburg 4,961,508 A 10/1990 Weimer et al. 4,997,108 A 3/1991 Hata D321,453 S * 11/1991 Ophardt D6/545 5,102,015 A * 4/1992 Barnard B67D 3/0019 222/135 D327,432 S 6/1992 Farricielli 5,125,542 A 6/1992 Blanc D328,007 S * 7/1992 Mondry D7/589 D328,008 S * 7/1992 Avery D7/589 D328,220 S * 7/1992 Barnard D7/313 5,142,610 A * 8/1992 Augustine A47J 31/54 222/146.5 5,150,802 A 9/1992 Jeffers 5,158,210 A 10/1992 Du 5,230,443 A 7/1993 Du D345,085 S * 3/1994 Sewell D7/589 5,325,995 A 7/1994 Harrison et al. 5,337,775 A 8/1994 Lane et al. 5,350,083 A 9/1994 Du 5,361,943 A 11/1994 Du 5,428,066 A 6/1995 Larner et al. 5,429,681 A 7/1995 Mesenbring 5,435,463 A 7/1995 Hodgson 5,435,466 A 7/1995 Du D365,962 S 1/1996 Amundsen et al. 5,490,613 A 2/1996 Taylor et al. D372,650 S 8/1996 Bundy 5,573,047 A 11/1996 Akin 5,579,945 A 12/1996 Ichikawa et al. 5,579,959 A 12/1996 Bennett et al. 5,622,484 A 4/1997 Taylor-McCune et al. 5,624,056 A 4/1997 Martindale D384,863 S * 10/1997 Danemayer D7/589 D385,715 S * 11/1997 Curry D7/589 D390,753 S * 2/1998 Danemayer D7/589 D392,843 S * 3/1998 Mulvihill D7/589 5,752,319 A 5/1998 Su et al. D398,964 S 9/1998 Doughty et al. 5,803,317 A 9/1998 Wheeler 5,833,120 A 11/1998 Evans et al. 5,836,482 A 11/1998 Ophardt et al. 5,845,812 A 12/1998 Morrison D408,667 S * 4/1999 Curry D6/515 6,003,733 A 12/1999 Wheeler 6,016,935 A 1/2000 Huegerich et al. 6,036,166 A 3/2000 Olson D425,792 S 5/2000 Haller 6,056,157 A 5/2000 Gehl et al. 6,082,587 A 7/2000 Martindale et al. 6,089,406 A 7/2000 Feldner 6,138,878 A 10/2000 Savage et al. 6,142,340 A * 11/2000 Watanabe B67D 1/0007 222/129.3 6,158,623 A 12/2000 Benavides et al.
---	---

(56) **References Cited**
 U.S. PATENT DOCUMENTS

1,556,206 A 4/1923 Dickey 1,528,283 A 3/1925 Whitesides 1,576,388 A 3/1926 Whitesides D83,729 S 3/1931 Hills 1,859,126 A 5/1932 Cock 1,912,304 A 5/1933 Phillips 2,244,071 A 6/1941 Landrus 2,442,126 A 5/1948 Halstead 2,609,122 A 9/1952 Stenerson D173,909 S 1/1955 Muller-Munk 2,713,988 A 7/1955 Kitterman 2,737,880 A 3/1956 Johnson 2,775,368 A 12/1956 De Vries 2,845,201 A 4/1958 Henry D183,532 S 9/1958 McCauley D184,606 S 3/1959 Cramer et al. D185,626 S 7/1959 Craig et al. D185,833 S 8/1959 Bruntjen D194,658 S 2/1963 Gilson 3,089,619 A 5/1963 Kass et al. 3,114,480 A 12/1963 Sauter D199,046 S 9/1964 Felske 3,173,579 A 3/1965 Curie et al. 3,248,011 A 4/1966 Brodsky et al. D204,822 S 5/1966 Barker D205,702 S 9/1966 Christine et al. 3,312,468 A 4/1967 Lynch 3,343,724 A 9/1967 Malpas D209,127 S 10/1967 Martin 3,366,278 A 1/1968 Fobes 3,369,720 A 2/1968 Libit et al. 3,387,903 A 6/1968 Karlen 3,445,039 A 5/1969 Brodsky et al. D215,045 S 8/1969 Benjamin 3,881,641 A 5/1975 Pliml et al. 3,924,777 A 12/1975 Peyser D240,108 S 6/1976 McGrew 4,018,357 A 4/1977 Ostrem 4,049,157 A 9/1977 Carson 4,176,767 A 12/1979 Franche, IV 4,214,675 A 7/1980 Schmit 4,314,654 A 2/1982 Gaubert	5,150,802 A 9/1992 Jeffers 5,158,210 A 10/1992 Du 5,230,443 A 7/1993 Du D345,085 S * 3/1994 Sewell D7/589 5,325,995 A 7/1994 Harrison et al. 5,337,775 A 8/1994 Lane et al. 5,350,083 A 9/1994 Du 5,361,943 A 11/1994 Du 5,428,066 A 6/1995 Larner et al. 5,429,681 A 7/1995 Mesenbring 5,435,463 A 7/1995 Hodgson 5,435,466 A 7/1995 Du D365,962 S 1/1996 Amundsen et al. 5,490,613 A 2/1996 Taylor et al. D372,650 S 8/1996 Bundy 5,573,047 A 11/1996 Akin 5,579,945 A 12/1996 Ichikawa et al. 5,579,959 A 12/1996 Bennett et al. 5,622,484 A 4/1997 Taylor-McCune et al. 5,624,056 A 4/1997 Martindale D384,863 S * 10/1997 Danemayer D7/589 D385,715 S * 11/1997 Curry D7/589 D390,753 S * 2/1998 Danemayer D7/589 D392,843 S * 3/1998 Mulvihill D7/589 5,752,319 A 5/1998 Su et al. D398,964 S 9/1998 Doughty et al. 5,803,317 A 9/1998 Wheeler 5,833,120 A 11/1998 Evans et al. 5,836,482 A 11/1998 Ophardt et al. 5,845,812 A 12/1998 Morrison D408,667 S * 4/1999 Curry D6/515 6,003,733 A 12/1999 Wheeler 6,016,935 A 1/2000 Huegerich et al. 6,036,166 A 3/2000 Olson D425,792 S 5/2000 Haller 6,056,157 A 5/2000 Gehl et al. 6,082,587 A 7/2000 Martindale et al. 6,089,406 A 7/2000 Feldner 6,138,878 A 10/2000 Savage et al. 6,142,340 A * 11/2000 Watanabe B67D 1/0007 222/129.3 6,158,623 A 12/2000 Benavides et al.
--	--

(56)

References Cited

U.S. PATENT DOCUMENTS

6,189,736 B1 2/2001 Phallen et al.
 6,193,111 B1 2/2001 Adams
 6,196,420 B1 3/2001 Gutierrez et al.
 6,223,944 B1 5/2001 Gehl et al.
 6,227,420 B1 5/2001 Jepson
 6,273,297 B1 8/2001 Schalow et al.
 D448,633 S 10/2001 Langlois
 D453,663 S * 2/2002 Mori D7/589
 6,345,734 B2 2/2002 Schalow et al.
 6,378,730 B1 4/2002 Reddy et al.
 6,405,897 B1 6/2002 Jepson et al.
 6,419,121 B1 * 7/2002 Gutierrez B67D 1/0004
 222/146.5
 D467,477 S 12/2002 Berens et al.
 6,488,179 B1 12/2002 Vujicic et al.
 D486,698 S * 2/2004 Hutchison D7/368
 6,691,894 B2 2/2004 Chrisman et al.
 6,698,624 B2 3/2004 Ufheil et al.
 6,708,741 B1 * 3/2004 Berry B67D 3/0009
 141/351
 6,722,530 B1 4/2004 King et al.
 6,726,061 B2 * 4/2004 Good B67D 3/0009
 222/105
 6,814,262 B1 11/2004 Adams et al.
 6,860,407 B2 3/2005 Gosselin
 6,871,015 B2 3/2005 Gutierrez et al.
 D506,369 S 6/2005 Norton
 D509,137 S 9/2005 Hierzer et al.
 6,938,801 B1 9/2005 Reddy et al.
 D515,919 S 2/2006 Hierzer et al.
 7,007,824 B2 * 3/2006 Danby B65D 77/30
 222/103
 7,025,230 B1 4/2006 Salmela
 7,147,134 B2 * 12/2006 Gutierrez B67D 1/0004
 222/146.1
 7,278,553 B2 10/2007 Py et al.
 7,322,491 B2 1/2008 Py et al.
 7,357,277 B2 4/2008 Verespej et al.
 7,455,200 B2 11/2008 Gehl et al.
 D583,022 S 12/2008 Soulier
 D585,965 S 2/2009 Kohler et al.
 D589,123 S 3/2009 Soulier
 7,651,015 B2 1/2010 Girard et al.
 D613,558 S 4/2010 Gold et al.
 7,731,060 B2 6/2010 Jones
 7,789,269 B2 9/2010 Pritchard
 D627,223 S 11/2010 Storti et al.
 D628,035 S 11/2010 Paige
 7,828,020 B2 11/2010 Girard et al.
 7,850,051 B2 12/2010 Py et al.
 D632,144 S 2/2011 Weisenbach
 7,980,424 B2 7/2011 Johnson
 8,091,735 B2 1/2012 Girard et al.
 8,146,780 B2 4/2012 Compton et al.
 D659,008 S 5/2012 Gately et al.
 8,205,771 B2 6/2012 Compton
 8,206,034 B2 6/2012 Keen et al.
 D671,620 S 11/2012 March et al.
 8,336,740 B1 * 12/2012 Daansen A47K 5/1207
 222/181.3
 8,353,428 B2 1/2013 Pritchard
 8,371,476 B2 2/2013 Weissbrod
 8,474,495 B2 7/2013 Singleton et al.
 8,528,807 B2 9/2013 Kaneko
 D696,943 S 1/2014 Kim
 8,887,960 B2 * 11/2014 Hardman A47F 1/03
 222/132
 D718,621 S 12/2014 Mitchell et al.
 D719,403 S 12/2014 Halioua
 D720,188 S * 12/2014 Burke D7/589
 D731,273 S 6/2015 McPeak Ford et al.
 D731,310 S 6/2015 Demey et al.
 9,045,260 B2 * 6/2015 Norris B67D 3/0029
 D754,536 S 4/2016 Arriaga

D755,045 S 5/2016 Kuo
 D758,810 S 6/2016 Peterson et al.
 9,370,273 B2 * 6/2016 Li A47J 31/41
 D763,077 S 8/2016 Mitchell et al.
 D764,912 S 8/2016 Houyoux
 9,585,513 B2 * 3/2017 Hanes A47J 31/465
 D782,907 S * 4/2017 Sowieja D9/447
 D792,164 S * 7/2017 Mitchell D7/589
 9,717,354 B2 * 8/2017 Gehl A47G 19/183
 D798,106 S * 9/2017 Sowieja D7/398
 2002/0092879 A1 7/2002 Chrisman et al.
 2002/0179605 A1 12/2002 Miani et al.
 2003/0015556 A1 1/2003 Wild et al.
 2003/0066978 A1 4/2003 Enerson
 2003/0116584 A1 6/2003 Gutierrez et al.
 2004/0222233 A1 11/2004 Gosselin
 2004/0238563 A1 12/2004 Lin
 2005/0121464 A1 6/2005 Miller et al.
 2005/0167443 A1 8/2005 Sanfilippo et al.
 2005/0167444 A1 8/2005 Sanfilippo et al.
 2005/0252937 A1 11/2005 Gehl et al.
 2006/0071020 A1 4/2006 Wiesner et al.
 2006/0138167 A1 6/2006 McMahan et al.
 2007/0029343 A1 2/2007 Sanfilippo et al.
 2008/0029540 A1 2/2008 Johnson
 2008/0078781 A1 4/2008 Py et al.
 2008/0083788 A1 4/2008 Py et al.
 2008/0105701 A1 5/2008 Niss et al.
 2008/0116225 A1 5/2008 Py et al.
 2008/0116226 A1 5/2008 Py et al.
 2008/0169309 A1 7/2008 Kroeger
 2008/0314923 A1 12/2008 Faller et al.
 2009/0020559 A1 1/2009 Sanfilippo et al.
 2009/0283541 A1 11/2009 Compton et al.
 2010/0038380 A1 2/2010 Compton
 2010/0147884 A1 6/2010 Compton et al.
 2010/0176155 A1 7/2010 Baron et al.
 2010/0264146 A1 10/2010 Casale et al.
 2010/0288767 A1 11/2010 Seelhofer
 2011/0017774 A1 1/2011 Pritchard
 2011/0024463 A1 2/2011 Py et al.
 2011/0042410 A1 2/2011 Paulen
 2012/0046785 A1 2/2012 Deo et al.
 2012/0152976 A1 7/2012 Yoshida et al.
 2012/0211519 A1 8/2012 Hauner et al.
 2015/0102057 A1 * 4/2015 Gehl B65D 75/5877
 222/81
 2017/0251846 A1 * 9/2017 Sowieja A47G 19/183
 2017/0251847 A1 * 9/2017 Gehl B65D 75/5877

FOREIGN PATENT DOCUMENTS

EP 0 538 91 2/1986
 EP 0 962 421 12/1999
 GB 2 154 991 9/1985
 JP 52-001760 2/1955
 KR 1020120099678 9/2012
 TW D122024 3/2008
 TW D122218 4/2008
 TW D165705 2/2015
 WO WO-2013/029163 3/2013

OTHER PUBLICATIONS

Balaji Tube Corporation. Valves. 2016. Available from Internet, http://www.balajitube.com/?page_id=55.
 DS Smith Plastics, <http://www.dssmith.com/plastics/offering/flexible-packaging--dispensing-solutions/rapak/rapak-bags/>, date accessed: Sep. 30, 2014, 3 pages.
 International Search Report and Written Opinion for International Application No. PCT/US2014/059119, dated Feb. 25, 2015, 12 pages.
 International Search Report and Written Opinion for International Application No. PCT/US2015/047491, dated Oct. 29, 2015, 14 pages.
 Liqui-Box, "Fitments", <http://www.liquibox.com/fitments>, date accessed: Sep. 26, 2014, 2 pages.

(56)

References Cited

OTHER PUBLICATIONS

Round Eye Supply, Gehls Dispenser Valve Chill Sauce Bag in Box. 2016. Available from Internet, <https://www.roundeyesupply.com/Gehis-Dispenser-Value-With-Chili-Sauce-Bag-In-Box-p/de439156.htm>.

Scholle Packaging, <http://www.scholle.com/products>, date accessed: Sep. 30, 2014, 3 pages.

Steeltubedirect.co.uk: ERW Tunnel section Steel Tube and Pipe. 1 page. Found online Nov. 7, 2016. Available from Internet, http://www.steeltubedirect.co.uk/product_selector.aspx?category+100002&shape=155.

* cited by examiner

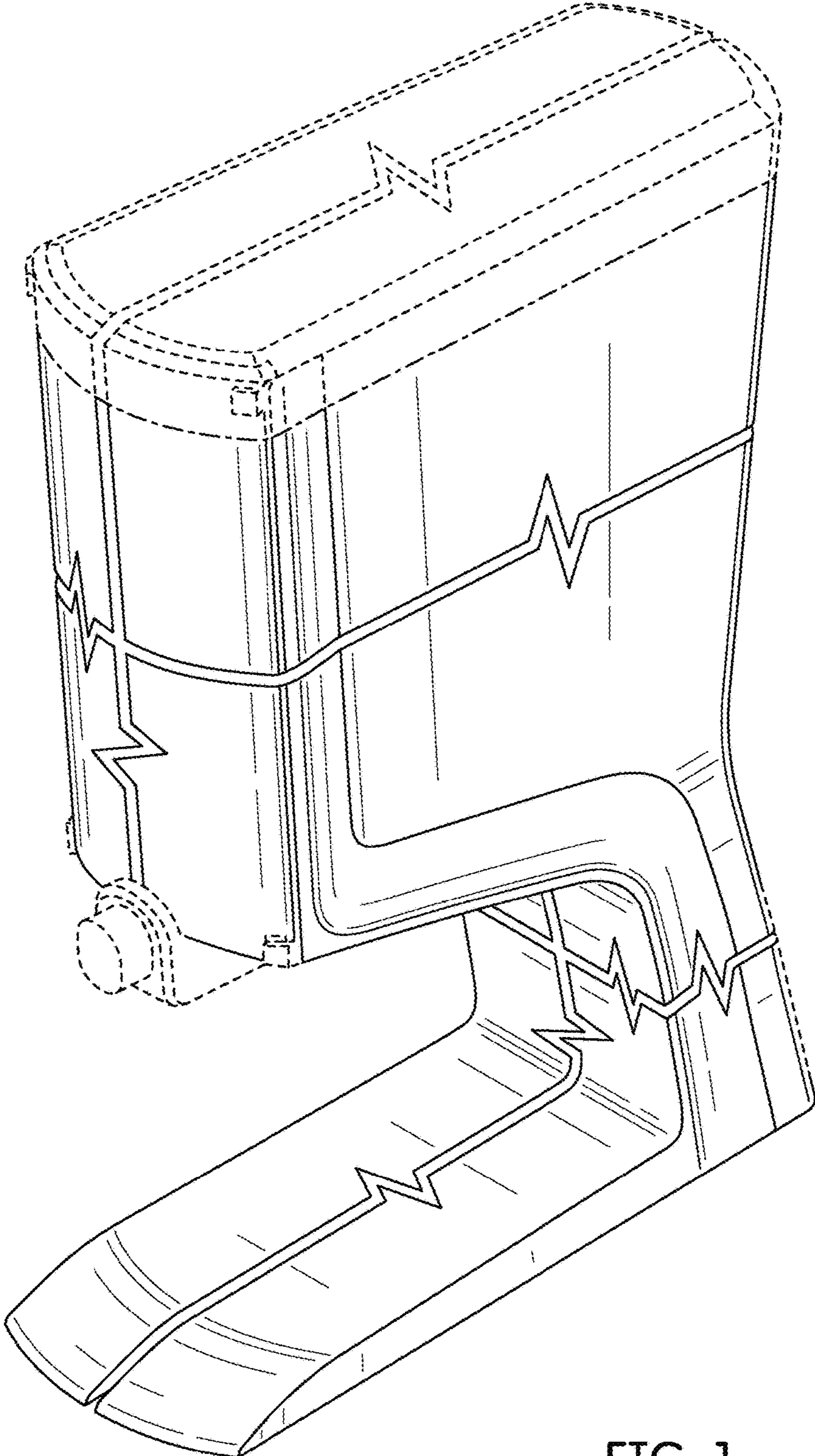

FIG. 1

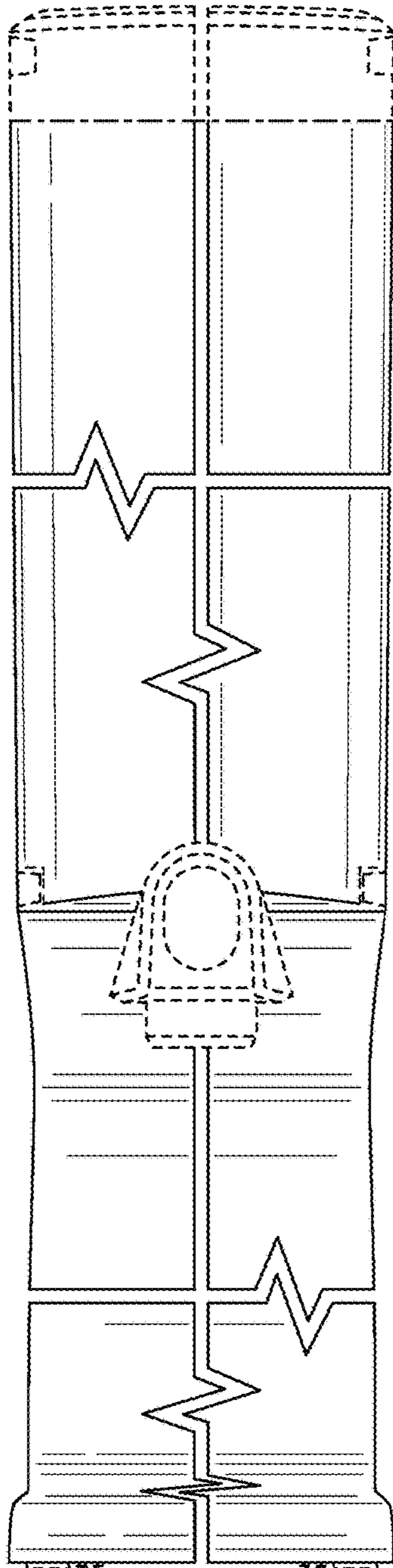

FIG. 2

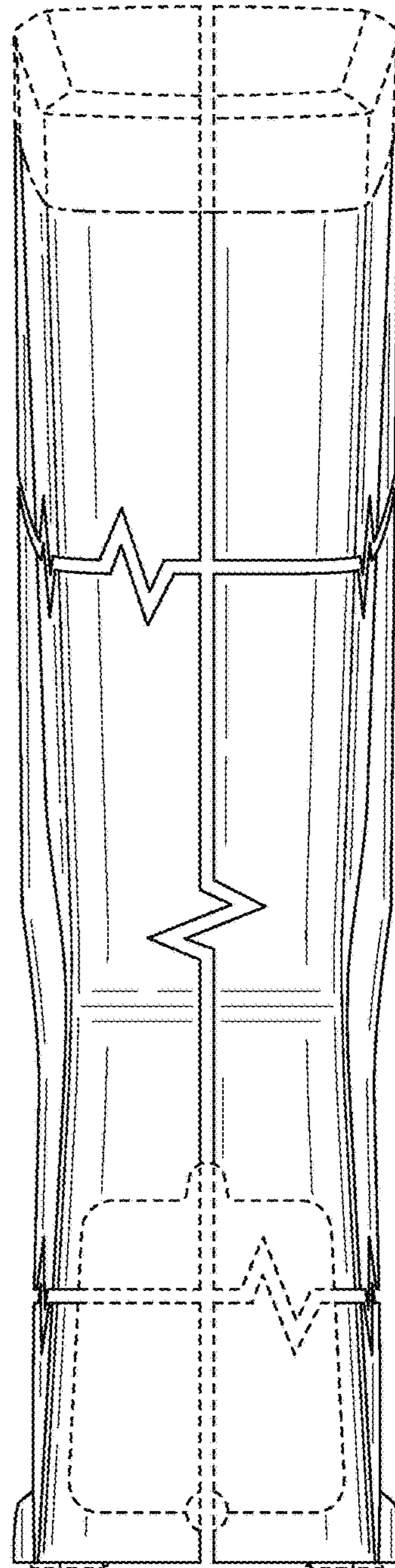

FIG. 3

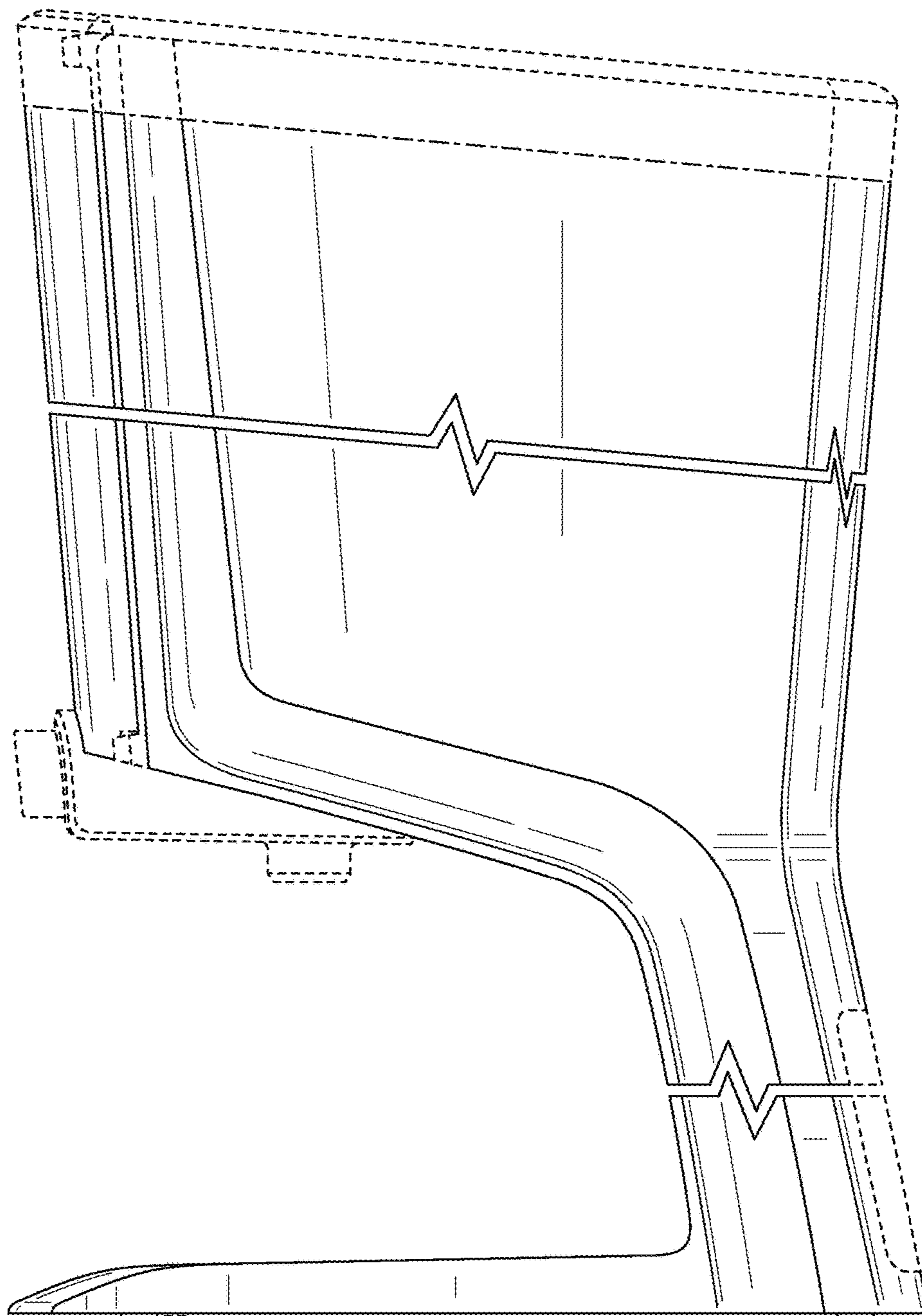

FIG. 4

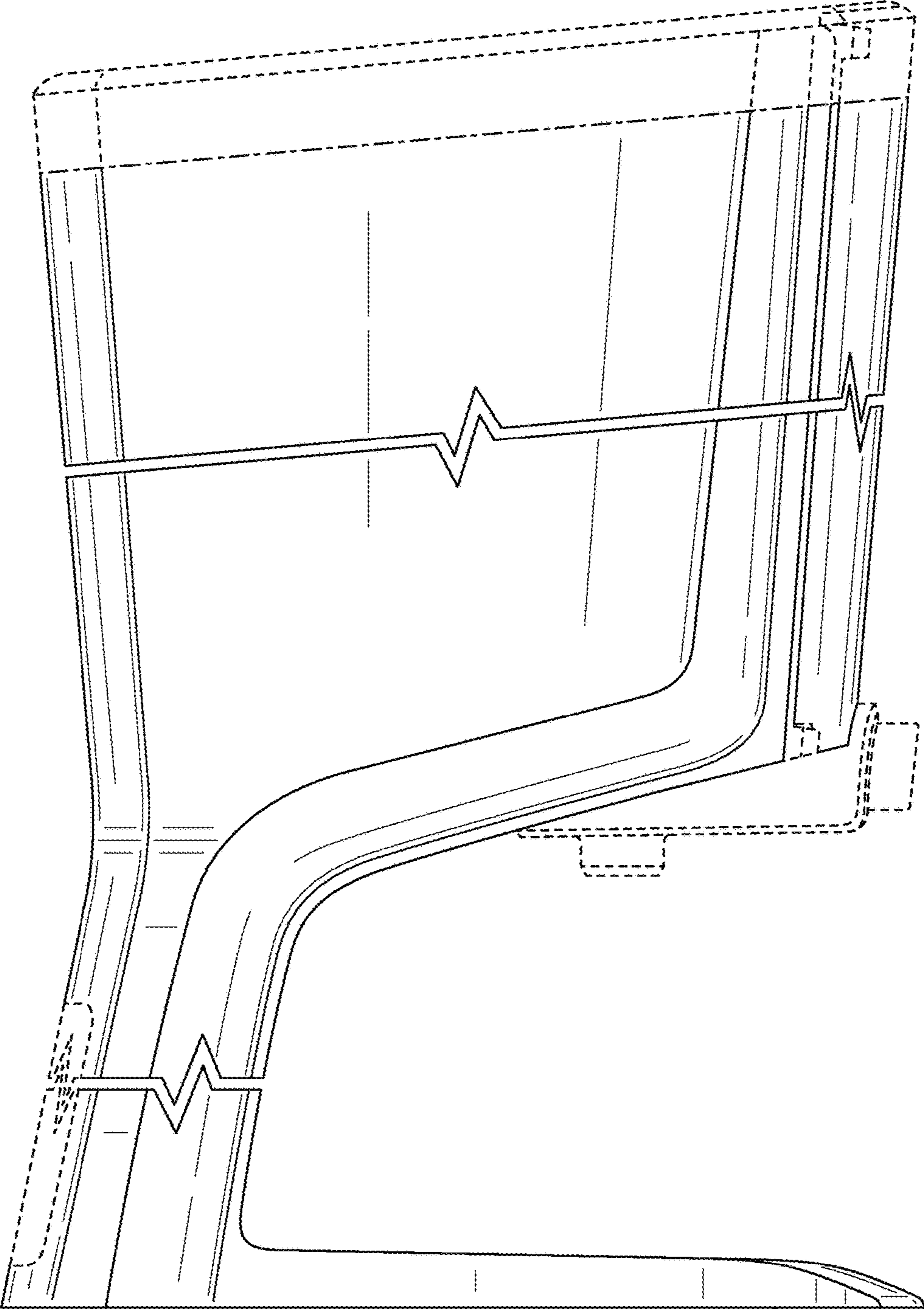

FIG. 5

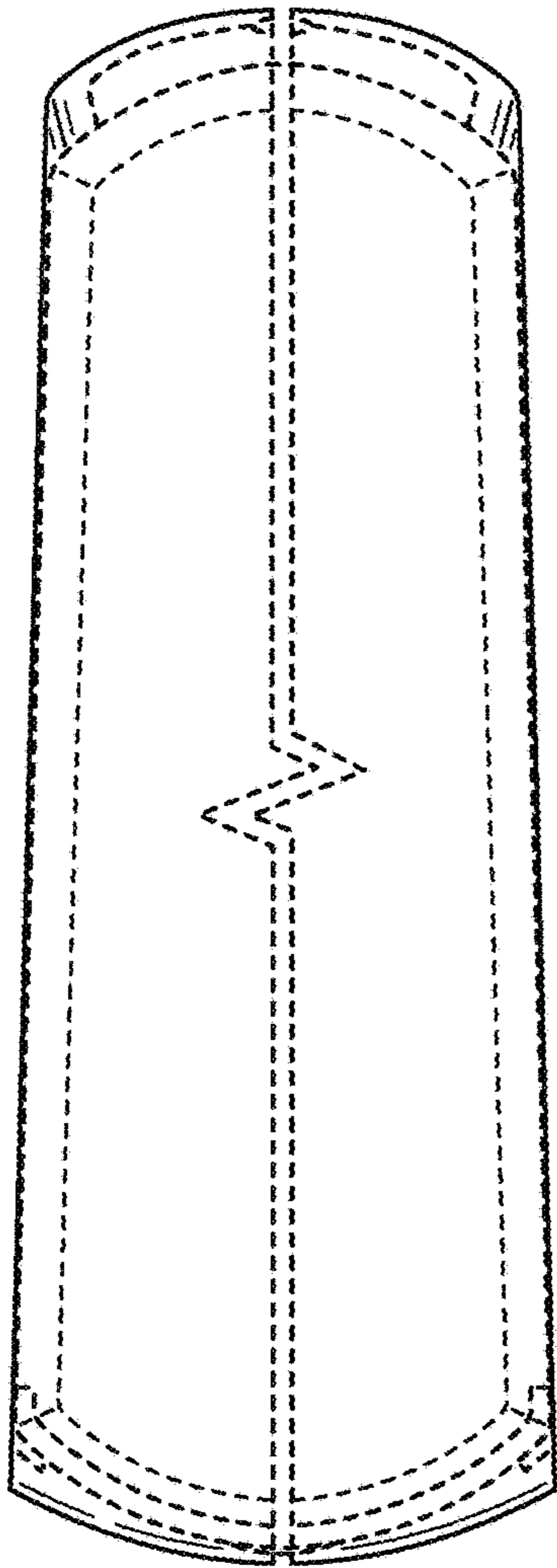

FIG. 6

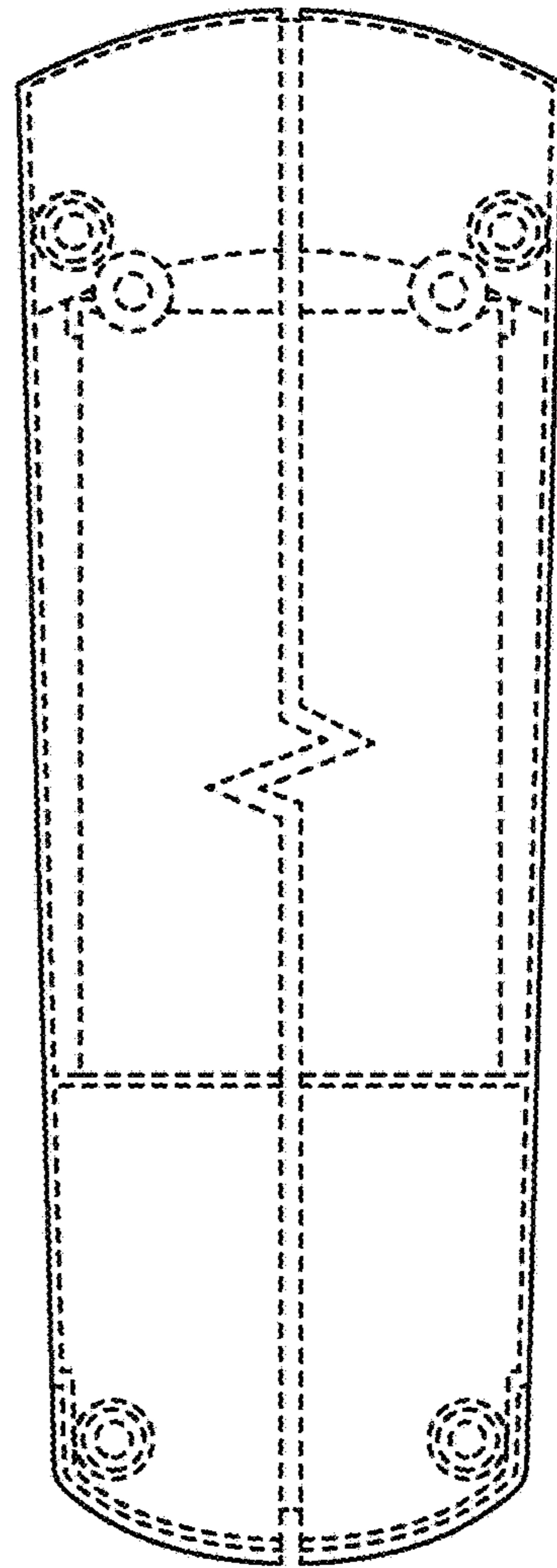

FIG. 7