



US00D820179S

(12) **United States Design Patent**
Kladde

(10) **Patent No.:** **US D820,179 S**
(45) **Date of Patent:** **** Jun. 12, 2018**

(54) **LUGGAGE BIN WEAR STRIP**

(71) Applicant: **Burkley U. Kladde**, Chandler, AZ (US)

(72) Inventor: **Burkley U. Kladde**, Chandler, AZ (US)

(**) Term: **15 Years**

(21) Appl. No.: **29/572,920**

(22) Filed: **Aug. 1, 2016**

(51) **LOC (11) Cl.** **12-08**

(52) **U.S. Cl.**
USPC **D12/190**

(58) **Field of Classification Search**

USPC D12/190, 192, 400, 90, 91, 92, 199, 197,
D12/86, 171, 169, 163, 110, 114

CPC B60R 13/043; B60R 2013/0293; B60R
13/02; B60R 13/04

See application file for complete search history.

(56) **References Cited**

U.S. PATENT DOCUMENTS

| | | | | |
|--------------|---------|------------|-------|---------|
| D636,314 S * | 4/2011 | Wang | | D12/190 |
| D647,833 S * | 11/2011 | Matei | | D12/190 |
| D704,606 S * | 5/2014 | Kirtland | | D12/172 |
| D746,745 S * | 1/2016 | Schoonover | | D12/190 |
| D748,549 S * | 2/2016 | Battams | | D12/190 |
| D761,175 S * | 7/2016 | Stoynov | | D12/190 |
| D795,144 S * | 8/2017 | Leetz | | D12/190 |
| D802,503 S * | 11/2017 | Leetz | | D12/190 |
| D811,301 S * | 2/2018 | Peat | | D12/190 |

* cited by examiner

Primary Examiner — Katrina A Betton

(74) *Attorney, Agent, or Firm* — Boardman & Clark LLP

(57) **CLAIM**

The ornamental design for a luggage bin wear strip, as shown and described.

DESCRIPTION

FIG. 1 is a front perspective view of the design of the luggage bin wear strip according to a first embodiment; FIG. 2 is a first end view of the design of the luggage bin wear strip shown in FIG. 1;

FIG. 3 is a second end view of the design of the luggage bin wear strip shown in FIG. 1;

FIG. 4 is a first side view of the design of the luggage bin wear strip shown in FIG. 1;

FIG. 5 is a second side view of the design of the luggage bin wear strip shown in FIG. 1;

FIG. 6 is a top plan view of the design of the luggage bin wear strip shown in FIG. 1;

FIG. 7 is a bottom plan view of the design of the luggage bin wear strip shown in FIG. 1;

FIG. 8 is a back perspective view of the design of the luggage bin wear strip shown in FIG. 1;

FIG. 9 is a front perspective view of the design of the luggage bin wear strip according to a second embodiment;

FIG. 10 is a first end view of the design of the luggage bin wear strip shown in FIG. 9;

FIG. 11 is a second end view of the design of the luggage bin wear strip shown in FIG. 9;

FIG. 12 is a first side view of the design of the luggage bin wear strip shown in FIG. 9;

FIG. 13 is a second side view of the design of the luggage bin wear strip shown in FIG. 9;

FIG. 14 is a top plan view of the design of the luggage bin wear strip shown in FIG. 9;

FIG. 15 is a bottom plan view of the design of the luggage bin wear strip shown in FIG. 9; and,

FIG. 16 is a back perspective view of the design of the luggage bin wear strip shown in FIG. 9.

The broken lines are provided for illustrative purposes only and form no part of the claimed design.

1 Claim, 10 Drawing Sheets

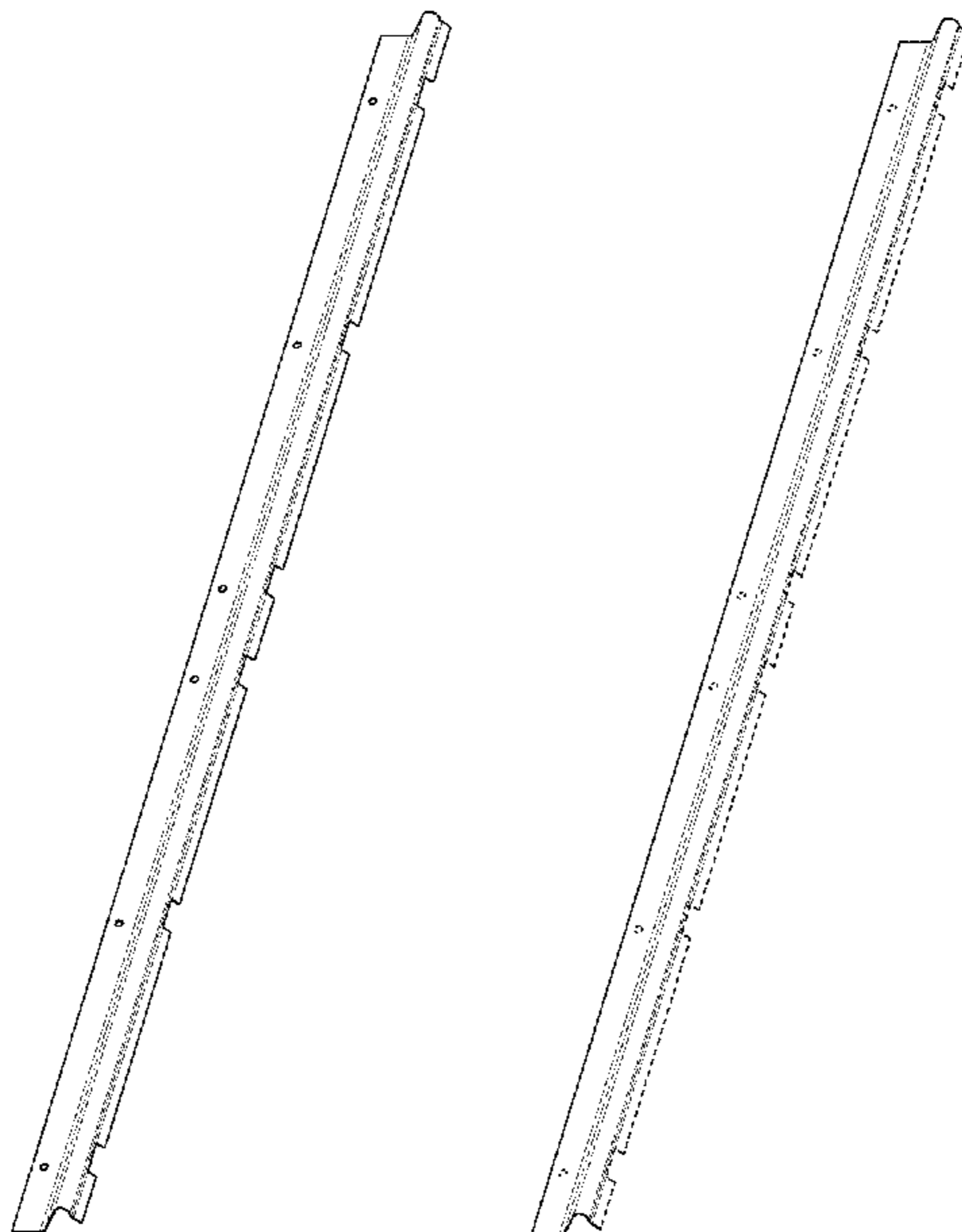

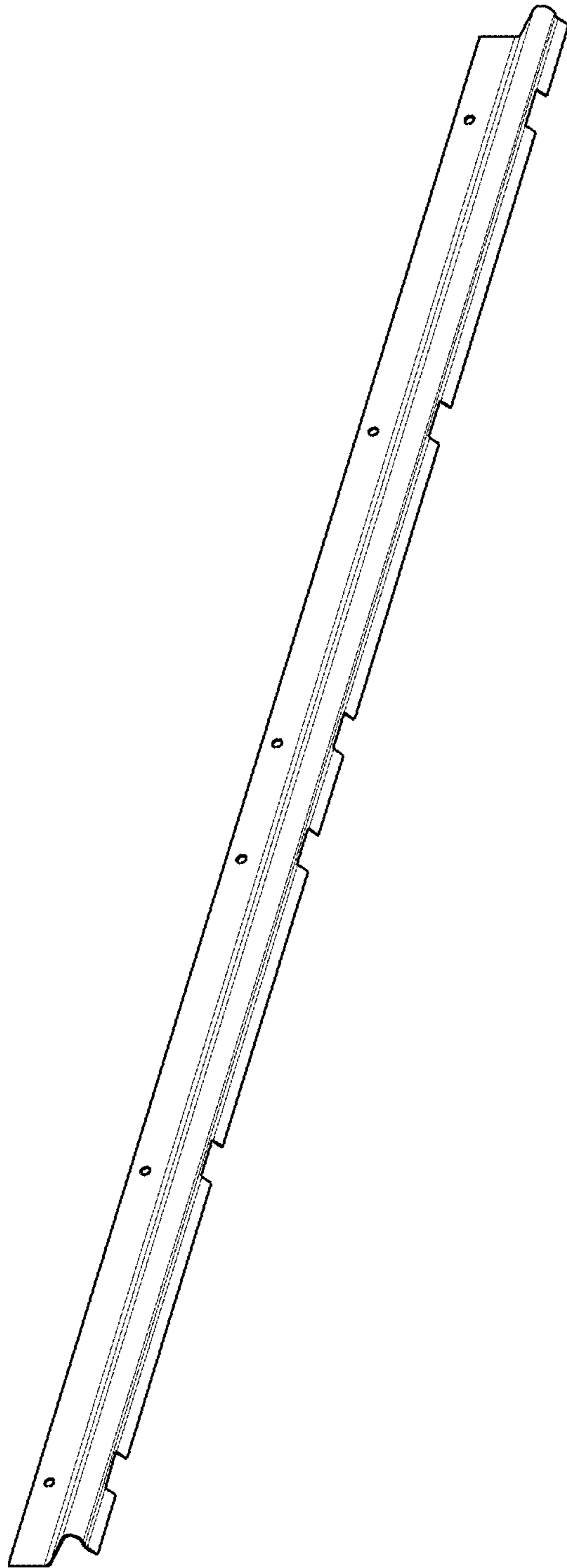

FIG. 1



FIG. 2



FIG. 3

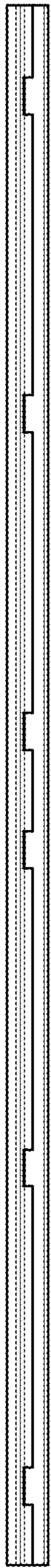

FIG. 4



FIG. 5

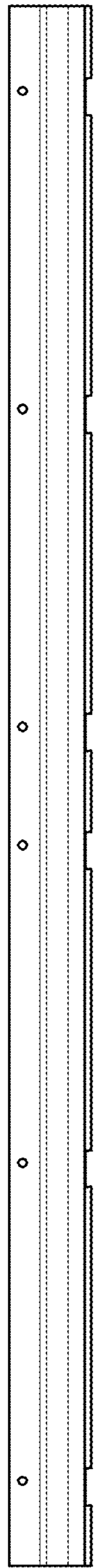

FIG. 6

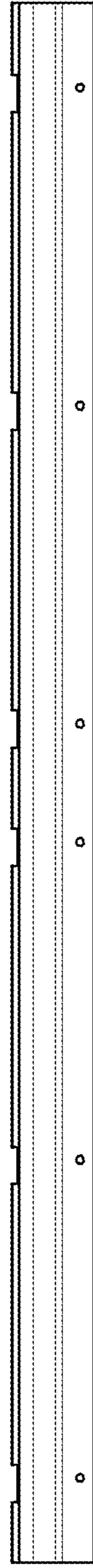

FIG. 7

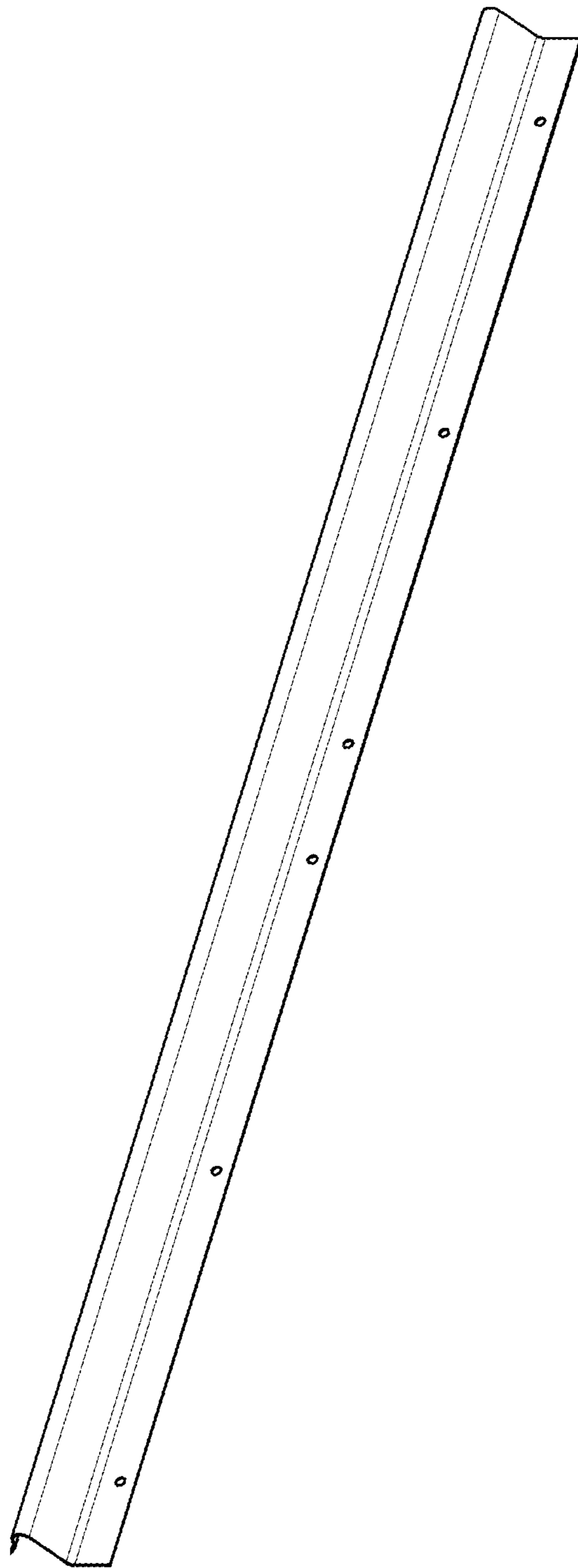

FIG. 8

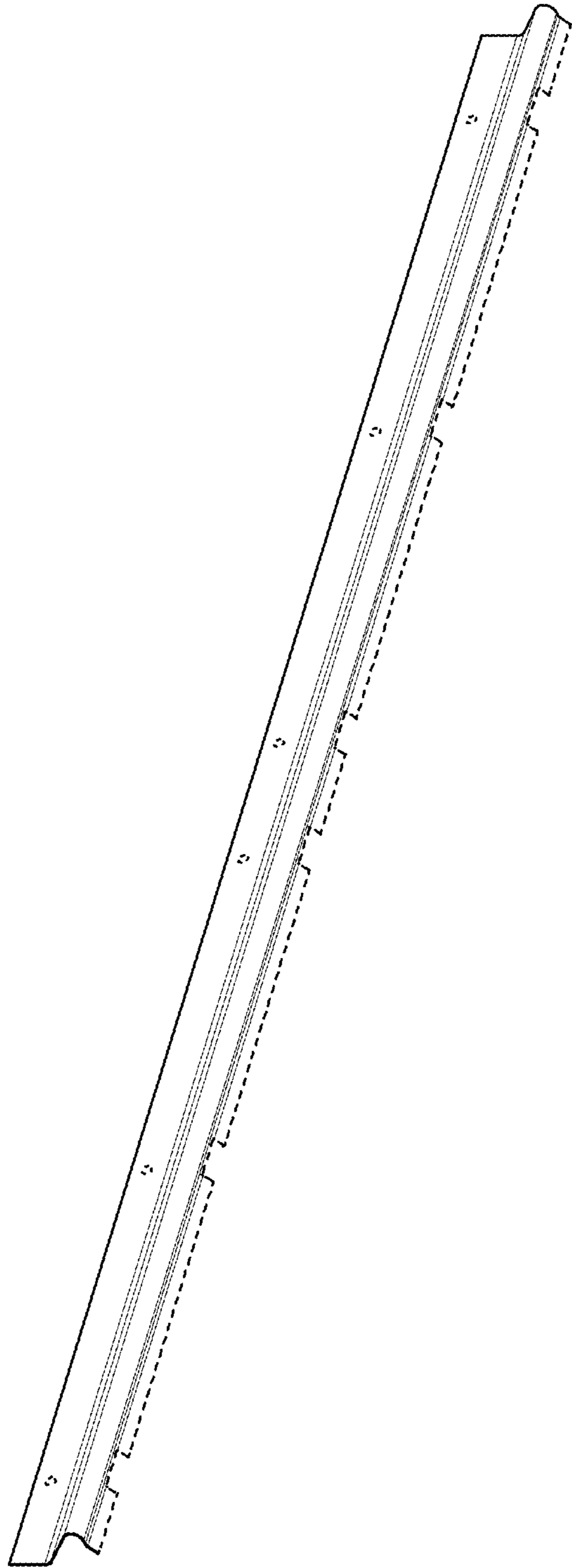

FIG. 9



FIG. 10



FIG. 11



FIG. 12



FIG. 13

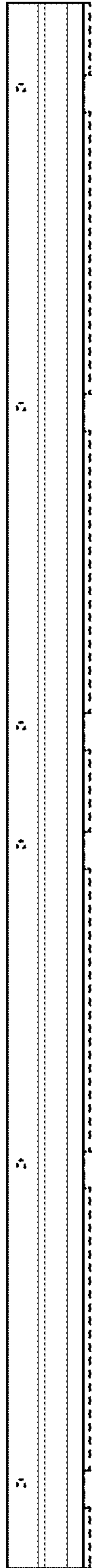

FIG. 14

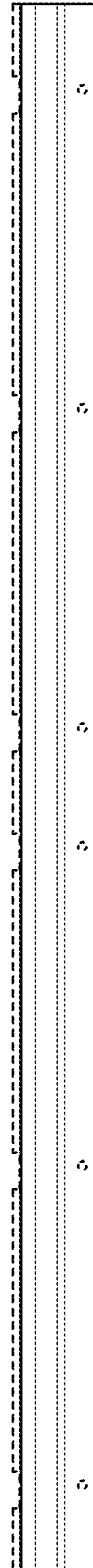

FIG. 15

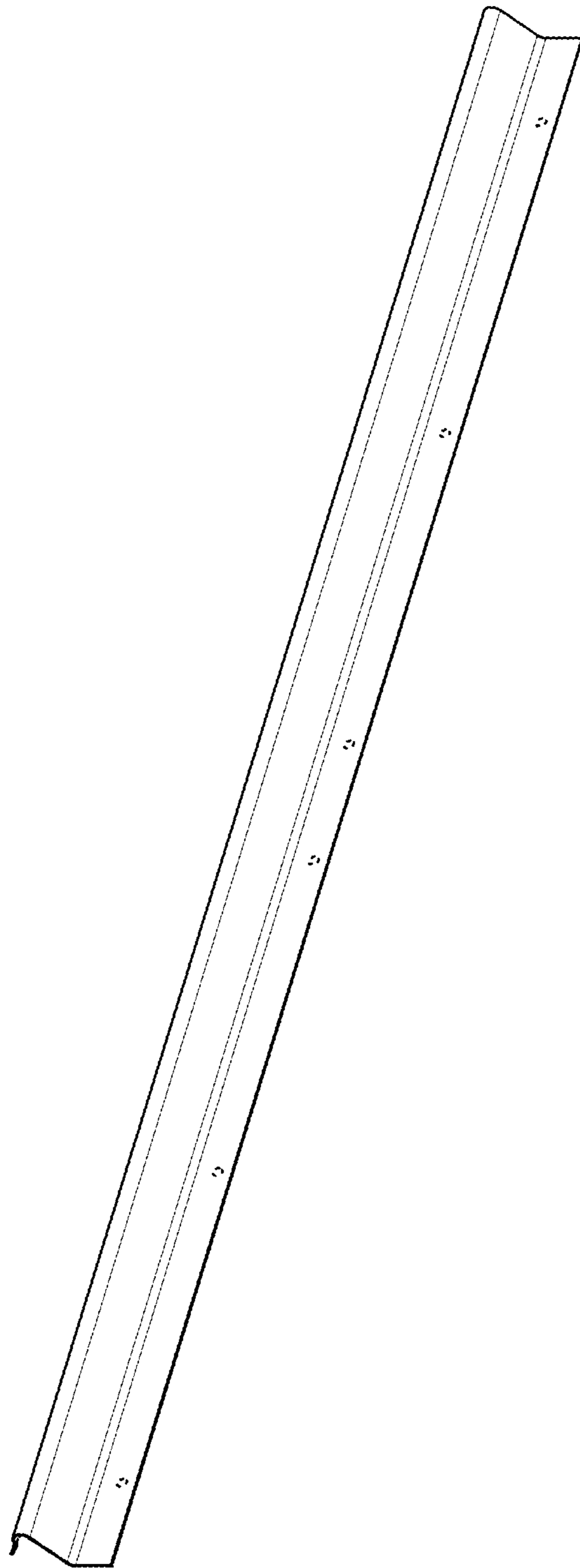

FIG. 16