



US00D819945S

(12) **United States Design Patent**  
**Escobar**

(10) **Patent No.:** **US D819,945 S**  
(45) **Date of Patent:** **\*\* Jun. 12, 2018**

- (54) **OUTSOLE**
- (71) Applicant: **Strategic Partners, Inc.**, Chatsworth, CA (US)
- (72) Inventor: **Rudy Escobar**, North Hills, CA (US)
- (73) Assignee: **Strategic Partners, Inc.**, Chatsworth, CA (US)
- (\*\*) Term: **15 Years**
- (21) Appl. No.: **29/538,337**
- (22) Filed: **Sep. 2, 2015**
- (51) **LOC (11) Cl.** ..... **02-04**
- (52) **U.S. Cl.**  
USPC ..... **D2/957; D2/947; D2/951**
- (58) **Field of Classification Search**  
USPC ..... D2/902, 906, 908, 916, 918, 925,  
D2/946-962, 977; 36/3 B, 22 R, 24.5,  
36/25 R, 28, 32 R, 34 R, 59 C, 67 A, 103  
CPC ..... A43B 13/00; A43B 13/02; A43B 13/023;  
A43B 13/026; A43B 13/04; A43B 13/08;  
A43B 13/10; A43B 13/12; A43B 13/14;  
A43B 13/141; A43B 13/143; A43B  
13/16; A43B 13/18; A43B 13/181; A43B  
13/187; A43B 13/189; A43B 13/20; A43B  
13/22; A43B 13/223; A43B 13/24; A43B  
13/28; A43B 13/30; A43B 13/32; A43B  
13/34; A43B 13/36  
See application file for complete search history.

- (56) **References Cited**  
U.S. PATENT DOCUMENTS  
296,519 A \* 4/1884 Brooks ..... A43B 13/223  
36/32 R  
D55,529 S \* 6/1920 Piper ..... D2/908  
D330,454 S \* 10/1992 Elliot ..... D2/955

- 6,006,451 A \* 12/1999 Morris ..... A43B 1/0027  
36/107
- 6,195,918 B1 \* 3/2001 Kelley ..... A43B 1/0027  
36/107
- D449,919 S \* 11/2001 McClaskie ..... D2/951
- D495,476 S \* 9/2004 Recchi ..... D2/947
- D505,249 S \* 5/2005 Urie ..... D2/953
- 6,993,858 B2 \* 2/2006 Seamans ..... A43B 1/0081  
36/11.5
- D524,018 S \* 7/2006 Deas ..... D2/947
- D530,492 S \* 10/2006 McClaskie ..... D2/953
- 7,146,751 B2 \* 12/2006 Seamans ..... A43B 1/0081  
36/11.5
- D648,512 S \* 11/2011 Schlageter ..... D2/896
- D664,748 S \* 8/2012 Lubart ..... D2/923
- D671,305 S \* 11/2012 Escobar ..... D2/947
- D671,306 S \* 11/2012 Tzenos ..... D2/947
- 8,322,050 B2 \* 12/2012 Lubart ..... A43B 13/223  
36/59 C
- D687,622 S \* 8/2013 Tzenos ..... D2/923
- D690,917 S \* 10/2013 Spring ..... D2/951
- D696,005 S \* 12/2013 Kubis ..... D2/951
- D706,524 S \* 6/2014 Smith ..... D2/947

(Continued)

*Primary Examiner* — T. Chase Nelson  
(74) *Attorney, Agent, or Firm* — Middleton Reutlinger

(57) **CLAIM**  
The ornamental design for an outsole, as shown and described.

**DESCRIPTION**  
FIG. 1 is a perspective view of my new design;  
FIG. 2 is a front view thereof;  
FIG. 3 is a rear view thereof;  
FIG. 4 is a right side elevation view thereof;  
FIG. 5 is a left side elevation view thereof;  
FIG. 6 is a top view thereof; and,  
FIG. 7 is a bottom view thereof.  
The broken lines in the drawings depict environmental subject matter only and form no part of the claimed design.

**1 Claim, 6 Drawing Sheets**

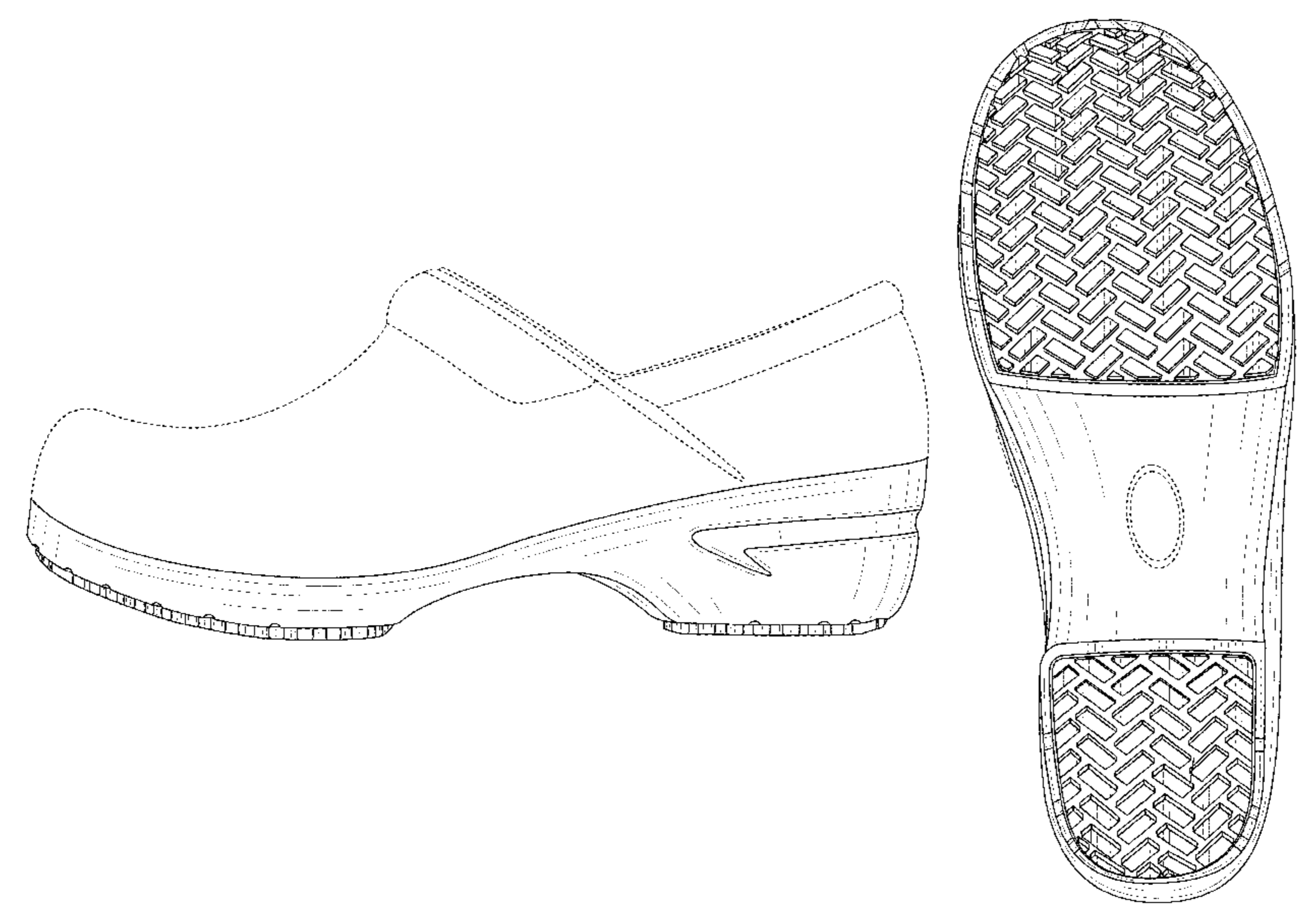

(56)

**References Cited**

U.S. PATENT DOCUMENTS

D728,911 S *	5/2015	Spring .....	D2/951
D729,503 S *	5/2015	Carroll .....	D2/902
D739,648 S *	9/2015	Engerman .....	D2/929
D747,860 S *	1/2016	De Costa Pereira Machado .....	D2/951
D779,181 S *	2/2017	Sassi .....	D2/957
2006/0059716 A1 *	3/2006	Yamashita .....	A43B 13/223 36/59 R

\* cited by examiner

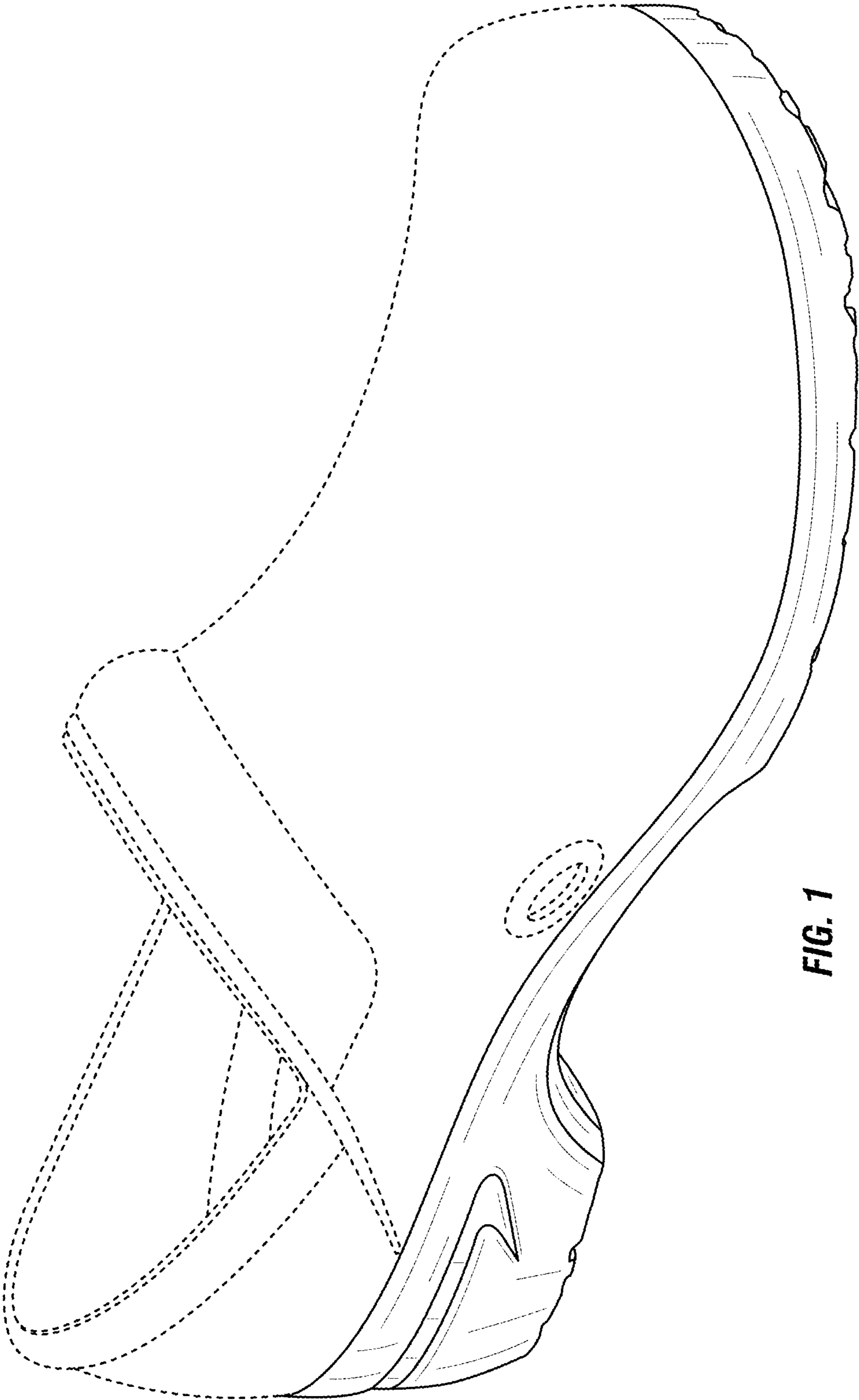
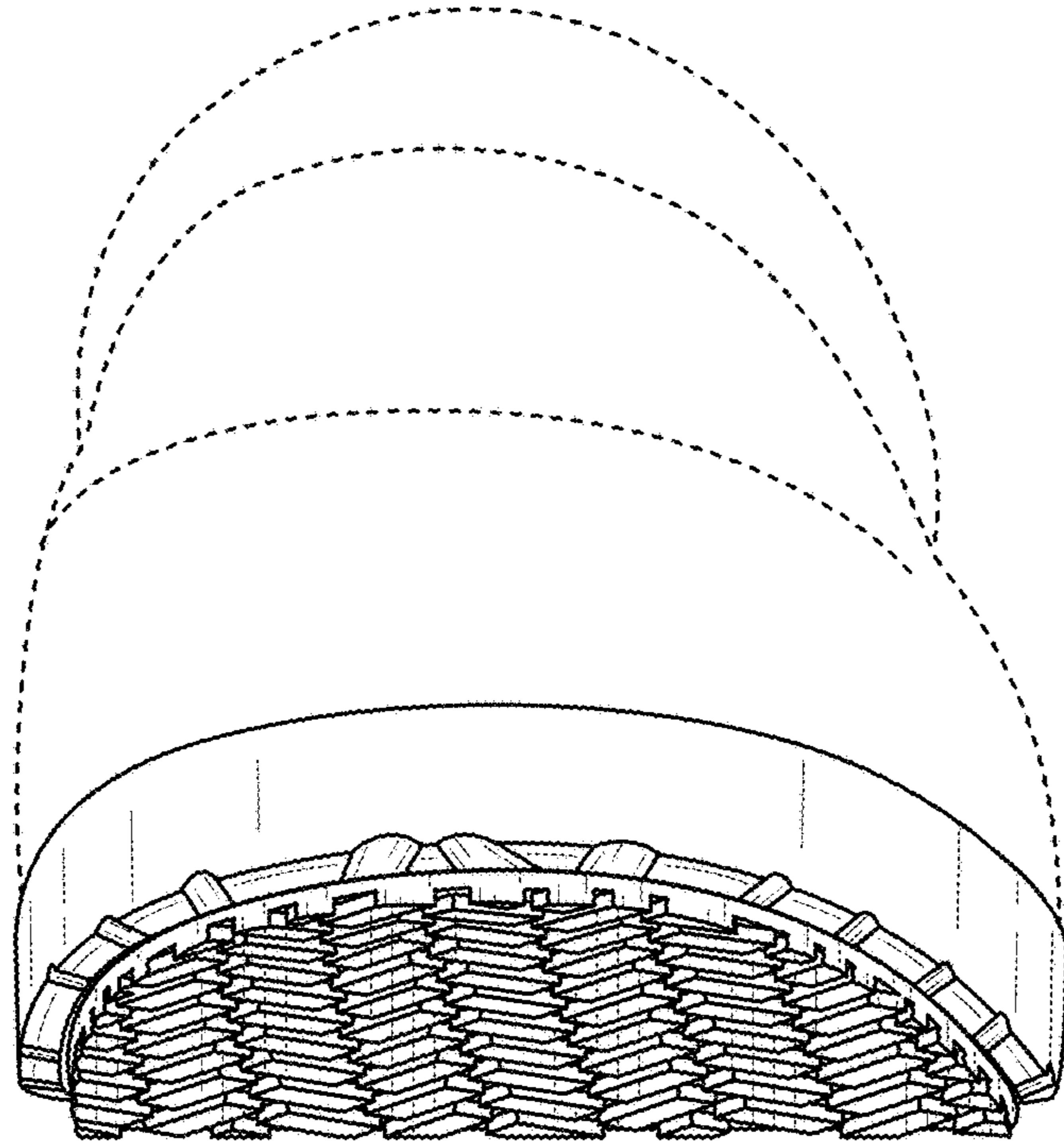
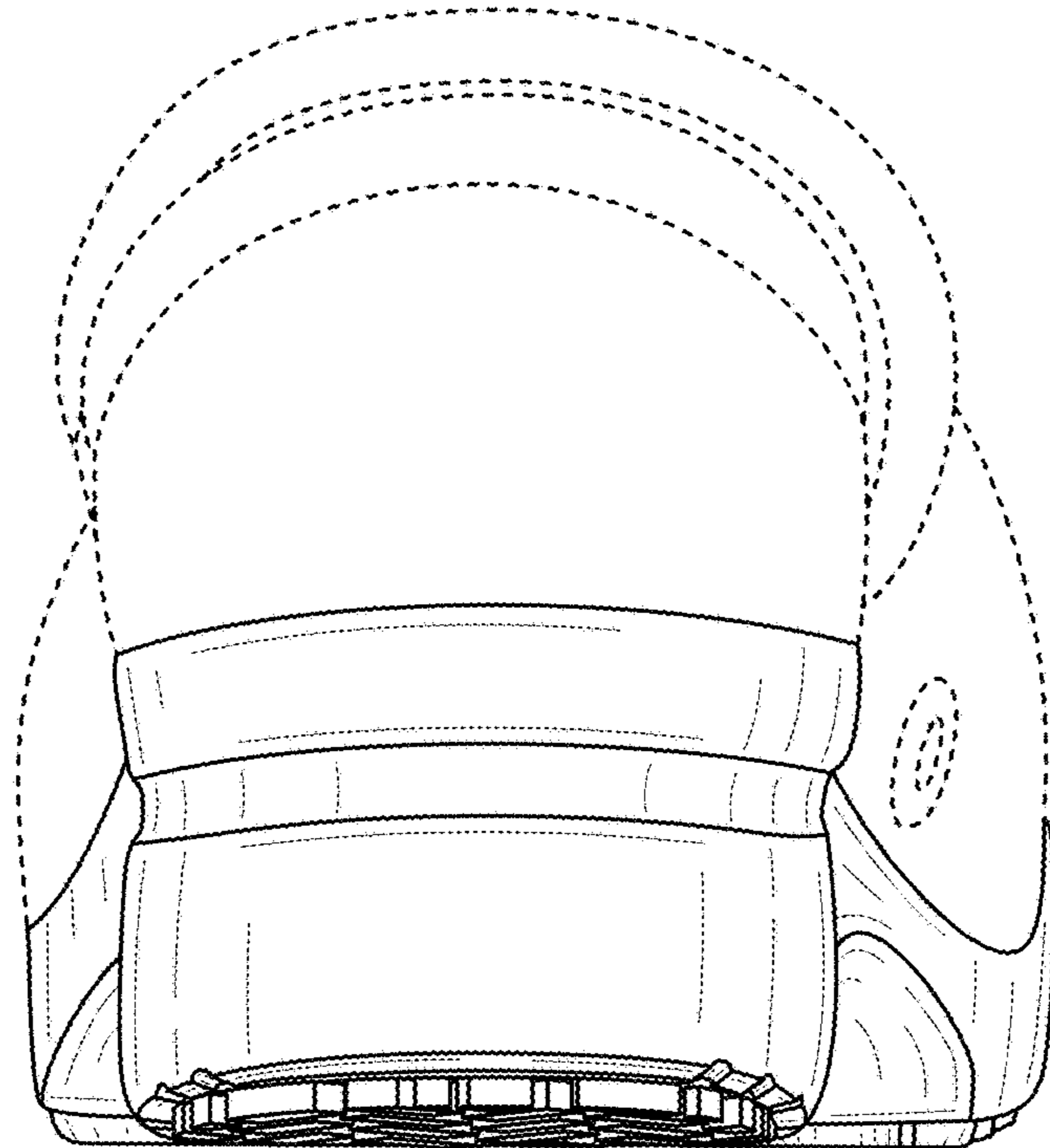

FIG. 1



**FIG. 2**



**FIG. 3**

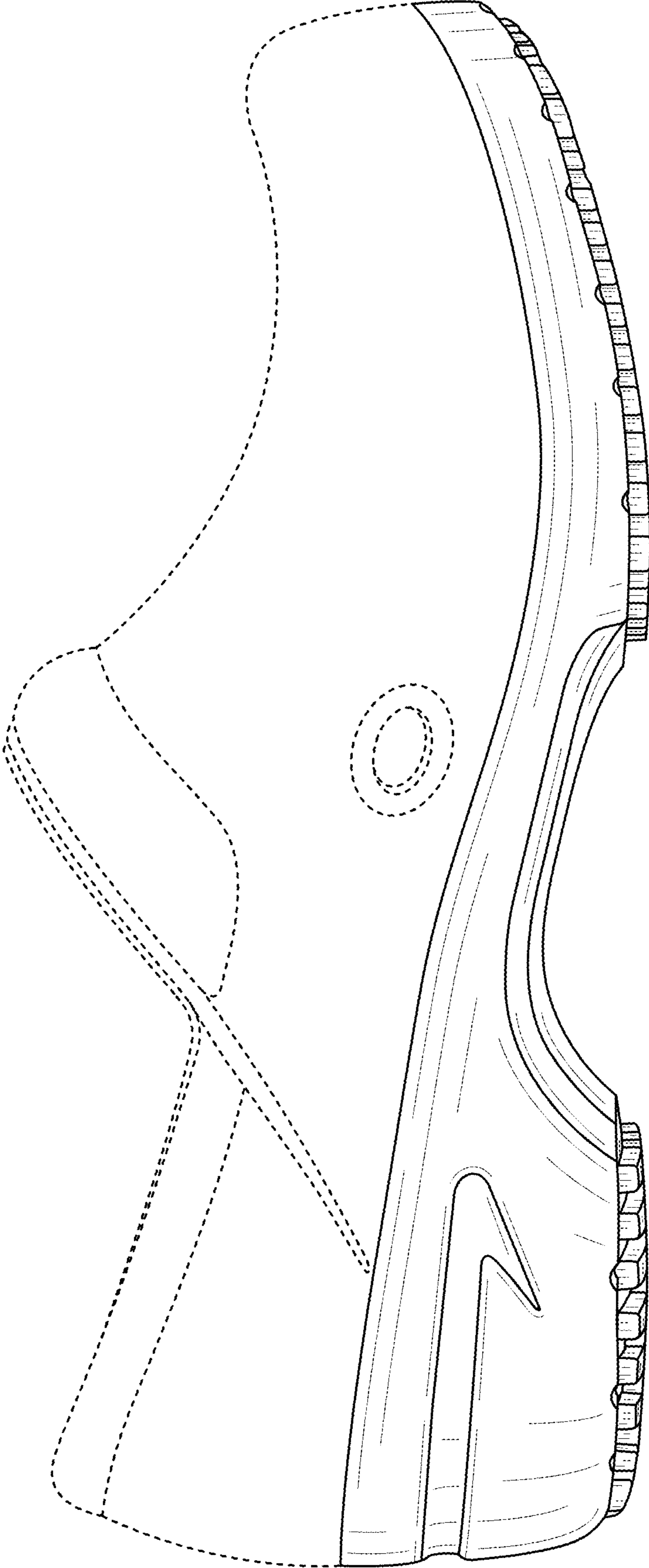

FIG. 4

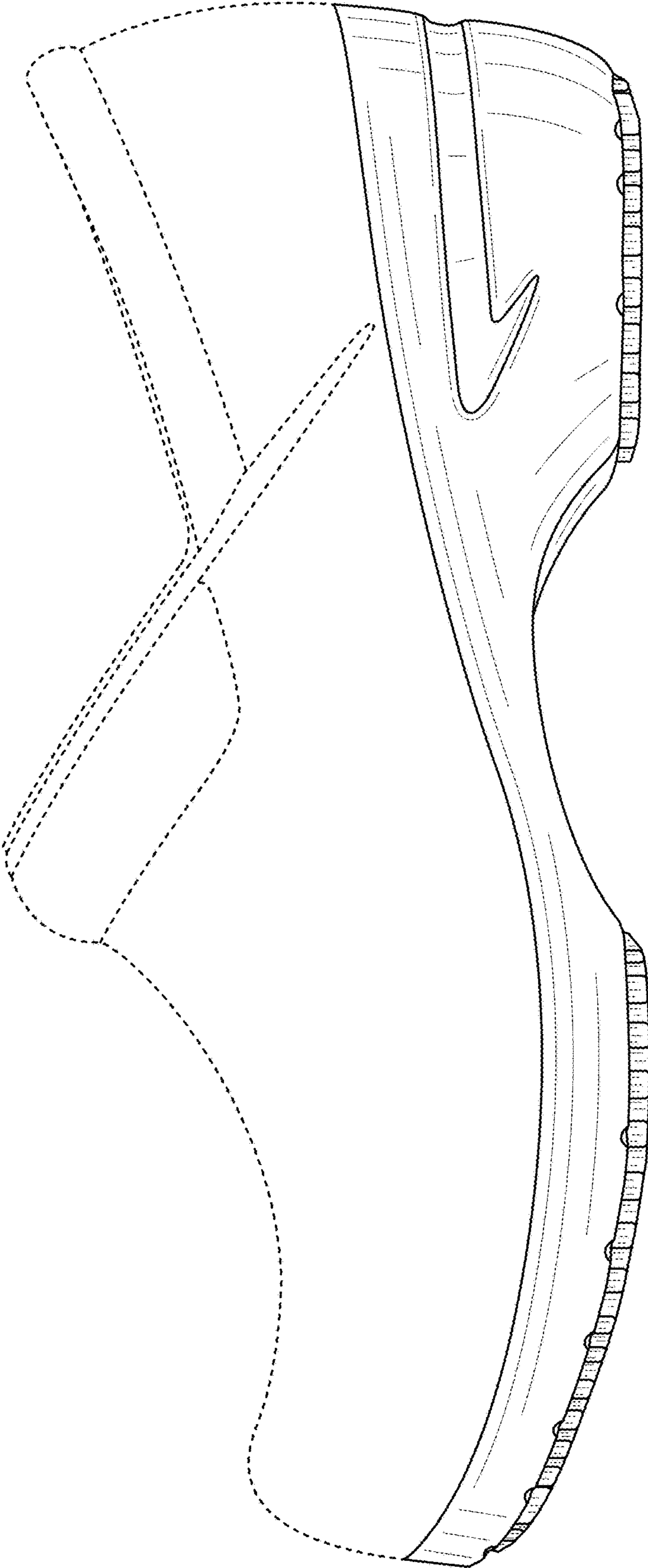
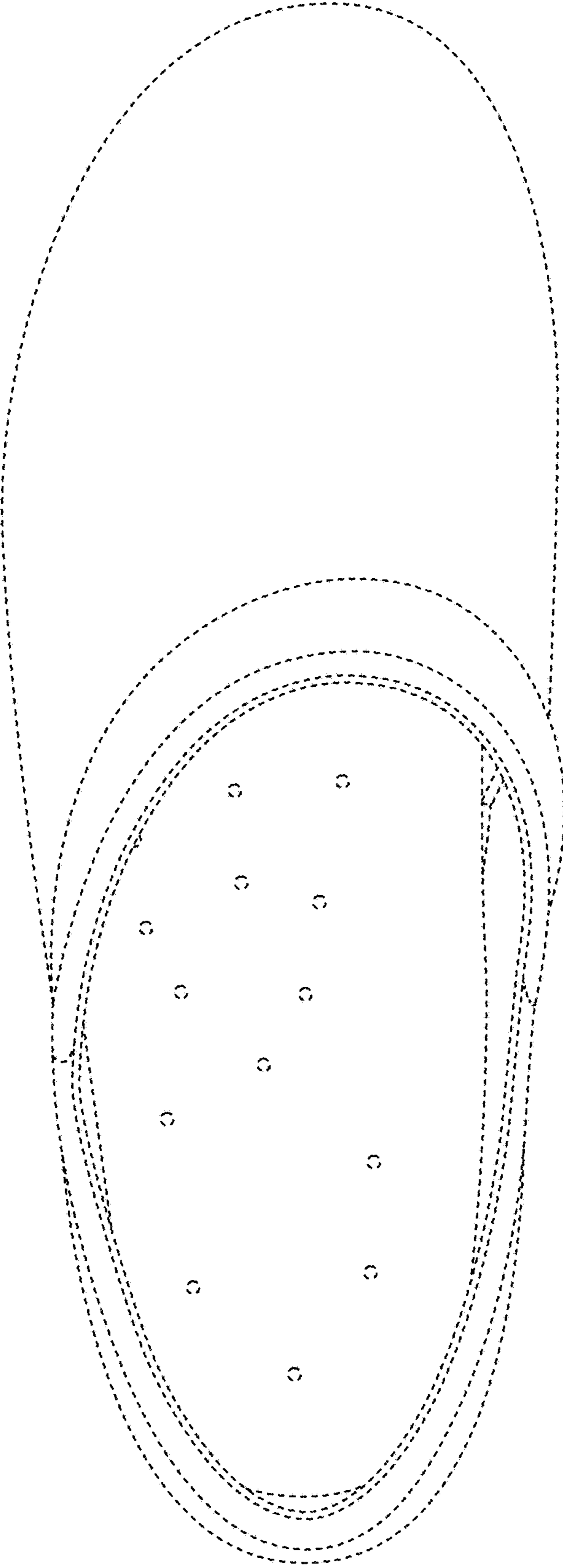

FIG. 5



**FIG. 6**

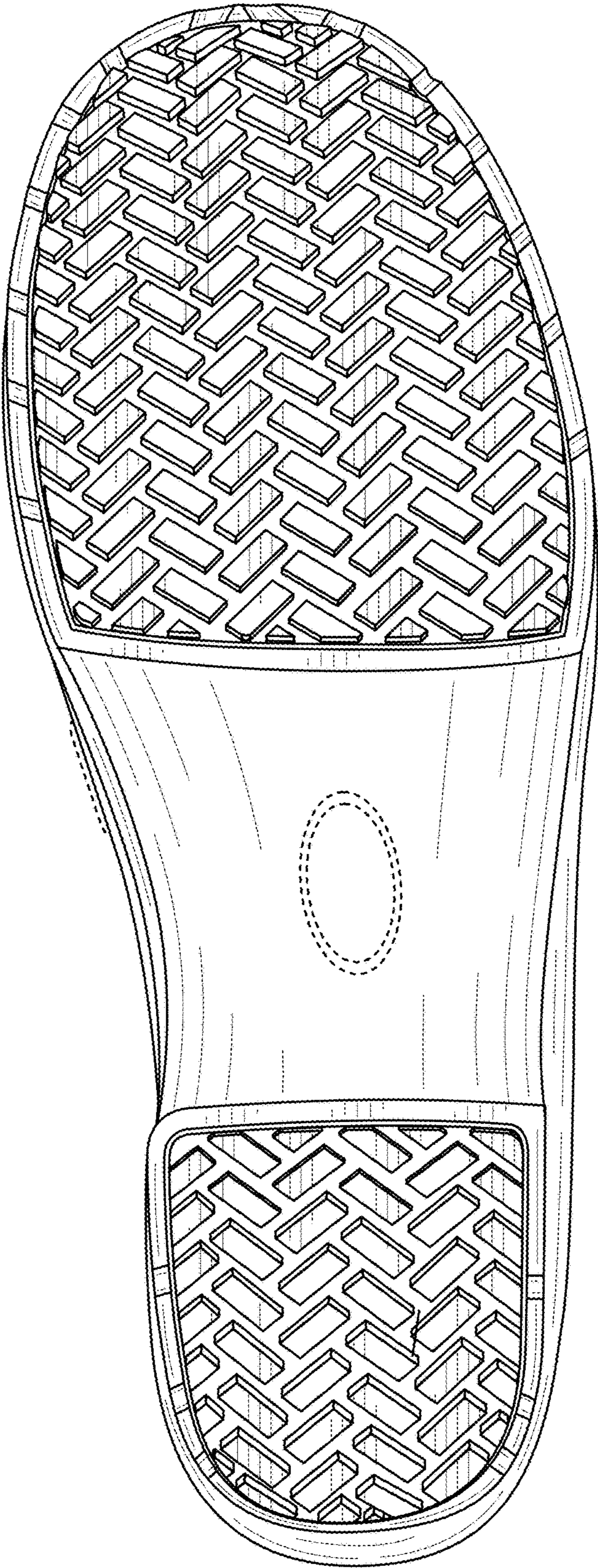

FIG. 7