



US00D819921S

(12) **United States Design Patent** (10) **Patent No.:** **US D819,921 S**
Pettinga (45) **Date of Patent:** **** Jun. 5, 2018**

(54) **CONVEYOR TRANSFER GUARD**
(71) Applicant: **Flexible Steel Lacing Company**,
Downers Grove, IL (US)
(72) Inventor: **Mark Steven Pettinga**, Hudsonville,
MI (US)
(73) Assignee: **Flexible Steel Lacing Company**,
Downers Grove, IL (US)
(**) Term: **15 Years**
(21) Appl. No.: **29/591,994**
(22) Filed: **Jan. 25, 2017**

Related U.S. Application Data

(62) Division of application No. 29/523,581, filed on Apr.
10, 2015, now Pat. No. Des. 780,399.
(51) **LOC (11) Cl.** **12-05**
(52) **U.S. Cl.**
USPC **D34/29**
(58) **Field of Classification Search**
USPC D34/29, 35; D8/499; 198/599, 844.1,
198/779, 600, 614
CPC B65G 21/2072; B65G 2201/02; B65G
47/66; B65G 47/52; B65G 17/08
See application file for complete search history.

(56) **References Cited**

U.S. PATENT DOCUMENTS

2,232,081 A 2/1941 Sloane
2,237,345 A 4/1941 Frentzel, Jr. et al.
(Continued)

FOREIGN PATENT DOCUMENTS

DE 3014608 A1 10/1981
DE 3224557 A1 1/1984
(Continued)

OTHER PUBLICATIONS

Extended European search report issued in European Application
No. 10751498.6 dated Dec. 19, 2016 (9 pages).
(Continued)

Primary Examiner — Cynthia Ramirez
(74) *Attorney, Agent, or Firm* — Fitch, Even, Tabin &
Flannery LLP

(57) **CLAIM**

I claim the ornamental design for a conveyor transfer guard,
as shown and described.

DESCRIPTION

FIG. 1 is a perspective view of a conveyor transfer guard,
showing my new design;
FIG. 2 is a right side elevational view thereof;
FIG. 3 is a left side elevational view thereof;
FIG. 4 is a top plan view thereof;
FIG. 5 is a bottom plan view thereof;
FIG. 6 is a front elevational view thereof;
FIG. 7 is a rear elevational view thereof;
FIG. 8 is a perspective view of a second embodiment of the
conveyor transfer guard;
FIG. 9 is a right side elevational view thereof;
FIG. 10 is a left side elevational view thereof;
FIG. 11 is a top plan view thereof;
FIG. 12 is a bottom plan view thereof;
FIG. 13 is a front elevational view thereof;
FIG. 14 is a rear elevational view thereof;
FIG. 15 is a perspective view of a third embodiment of the
conveyor transfer guard;
FIG. 16 is a right side elevational view thereof;
FIG. 17 is a left side elevational view thereof;
FIG. 18 is a top plan view thereof;
FIG. 19 is a bottom plan view thereof;
FIG. 20 is a front elevational view thereof; and,
FIG. 21 is a rear elevational view thereof.
The broken lines in the figures are included for the purpose
of illustrating portions of the conveyor transfer guard and
form no part of the claimed design.

1 Claim, 18 Drawing Sheets

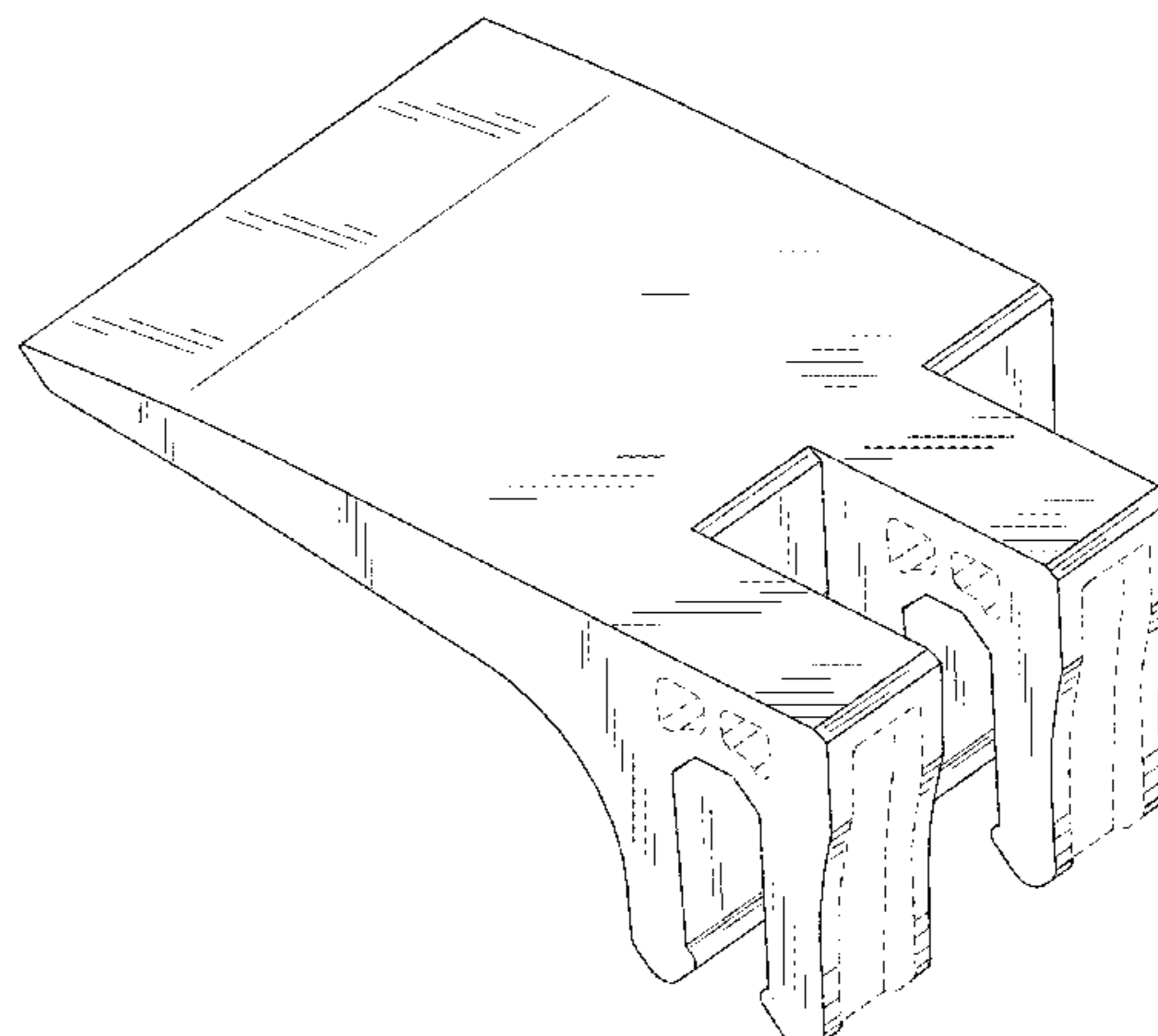
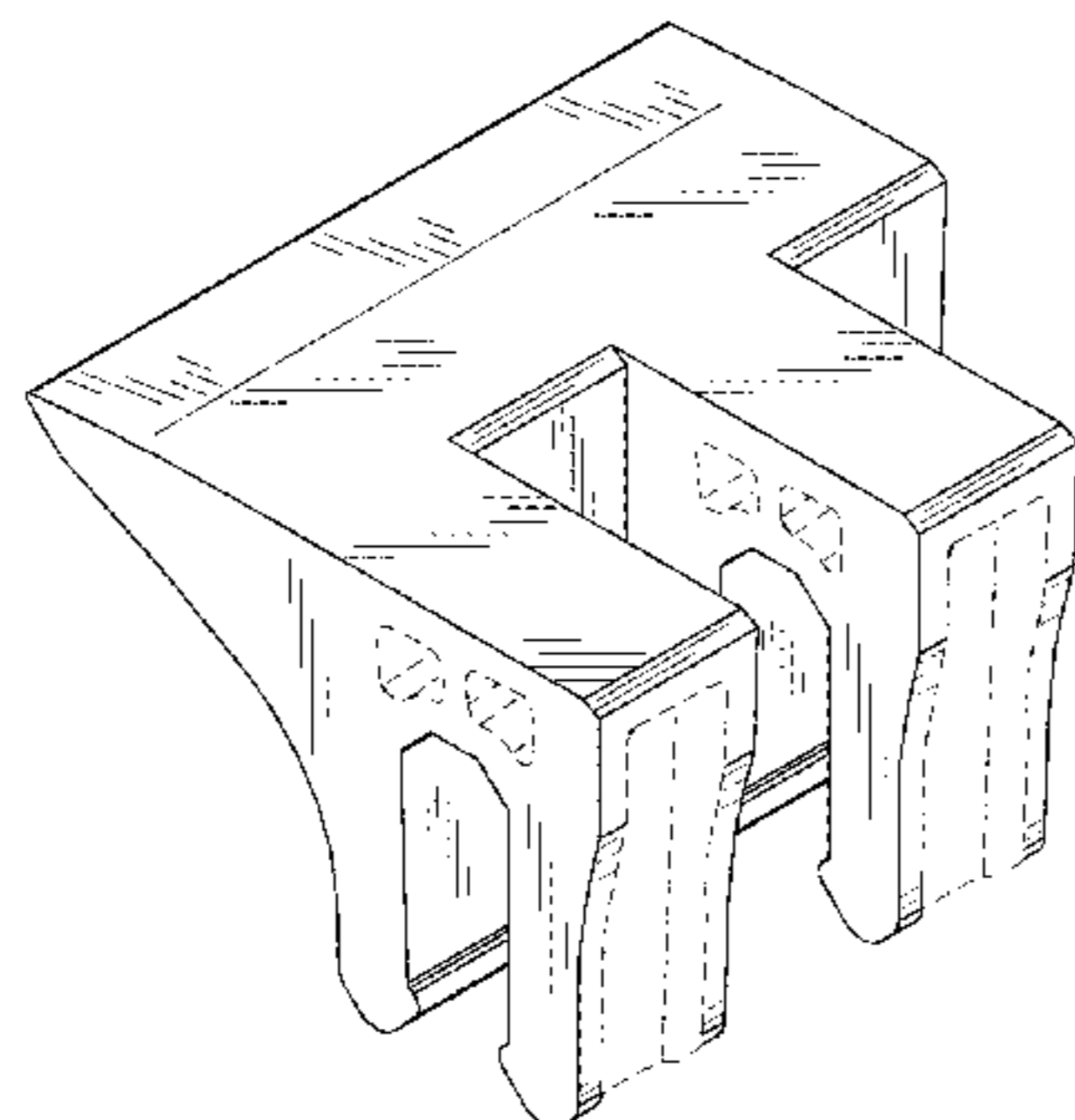

(56)

References Cited

U.S. PATENT DOCUMENTS

2,268,724 A 1/1942 Shackelford
 2,517,983 A 8/1950 Crosland
 2,536,961 A 1/1951 Smith
 2,624,444 A 1/1953 Casabona
 2,899,086 A 8/1959 Saint-Andre
 D209,071 S 10/1967 Koch
 3,345,957 A 10/1967 Welch
 D209,421 S 11/1967 Fabian
 3,465,489 A 9/1969 Monaghan
 3,548,996 A 12/1970 Ellis
 3,587,674 A 6/1971 Adkin
 3,623,598 A 11/1971 Anfossi
 3,738,650 A 6/1973 Ossenkop et al.
 3,878,735 A 4/1975 Preuss
 3,988,800 A 11/1976 Sachser
 3,988,880 A 11/1976 Miyazaki et al.
 4,096,943 A 6/1978 Gentsch
 4,288,208 A 9/1981 Kusters
 4,613,036 A 9/1986 Bourgeois
 4,718,543 A 1/1988 Leisner et al.
 D303,974 S 10/1989 Karr
 4,989,723 A 2/1991 Bode et al.
 5,009,307 A 4/1991 Chance et al.
 5,044,485 A 9/1991 Loder
 5,065,222 A 11/1991 Ishii
 5,215,182 A 6/1993 Garbagnati
 5,311,982 A 5/1994 Clopton
 5,320,478 A 6/1994 Gonsowski et al.
 5,344,001 A 9/1994 Kawaai et al.
 5,584,373 A 12/1996 Layne
 5,597,062 A 1/1997 Biwer
 5,597,063 A 1/1997 Bogle et al.
 5,695,042 A 12/1997 van der Burgt
 D407,174 S 3/1999 Baker
 5,957,265 A 9/1999 Clopton
 5,971,129 A 10/1999 Stawniak et al.
 D419,742 S 1/2000 Abbestam
 6,138,819 A 10/2000 Bogle et al.
 6,164,435 A 12/2000 Coen et al.
 6,550,604 B2 4/2003 MacLachlan
 6,630,633 B1 10/2003 Uber et al.
 D483,168 S 12/2003 McDaniel
 D484,545 S 12/2003 McIlvaine
 D493,933 S 8/2004 Schwagermann

6,896,122 B2 5/2005 Gambrell et al.
 6,959,803 B1 11/2005 Layne et al.
 7,210,569 B1 5/2007 Tarhan et al.
 D547,523 S 7/2007 Swinderman
 7,258,225 B2 8/2007 Hall
 7,523,820 B1 4/2009 Wu et al.
 8,042,682 B2 10/2011 Ertel
 8,162,133 B2 4/2012 Ruge
 8,210,341 B2 7/2012 Marshall et al.
 8,365,899 B2 2/2013 Mckee
 9,022,207 B2 5/2015 Tully et al.
 D780,399 S * 2/2017 Pettinga D34/29
 2005/0173858 A1 8/2005 Temler et al.
 2006/0070966 A1 4/2006 Koudys et al.
 2006/0108204 A1 5/2006 Marsetti
 2007/0023257 A1 2/2007 Schiesser
 2008/0296129 A1 12/2008 Yagi et al.
 2010/0108467 A1 5/2010 Barreyre et al.
 2011/0132725 A1 6/2011 Marshall et al.
 2015/0291368 A1 10/2015 Pettinga

FOREIGN PATENT DOCUMENTS

DE 8700878 3/1987
 DE 19858521 A1 6/2000
 DE 202006003116 U1 4/2006
 EP 0778229 A2 6/1997
 EP 0906879 A1 4/1999
 EP 0919493 A1 6/1999
 GB 1352993 5/1974
 JP H1115264 A 1/1999
 JP H11199038 7/1999
 JP 2000177836 A 6/2000
 RU 590213 1/1978
 RU 1159859 A 6/1985
 RU 1328266 A1 8/1987
 WO 2011071743 A1 6/2011

OTHER PUBLICATIONS

Notification of Transmittal of the International Search Report and the Written Opinion of the International Searching Authority, or the Declaration from the International Bureau of WIPO for related International Application No. PCT/US15/25484, dated Sep. 11, 2015, 10 pages.

* cited by examiner

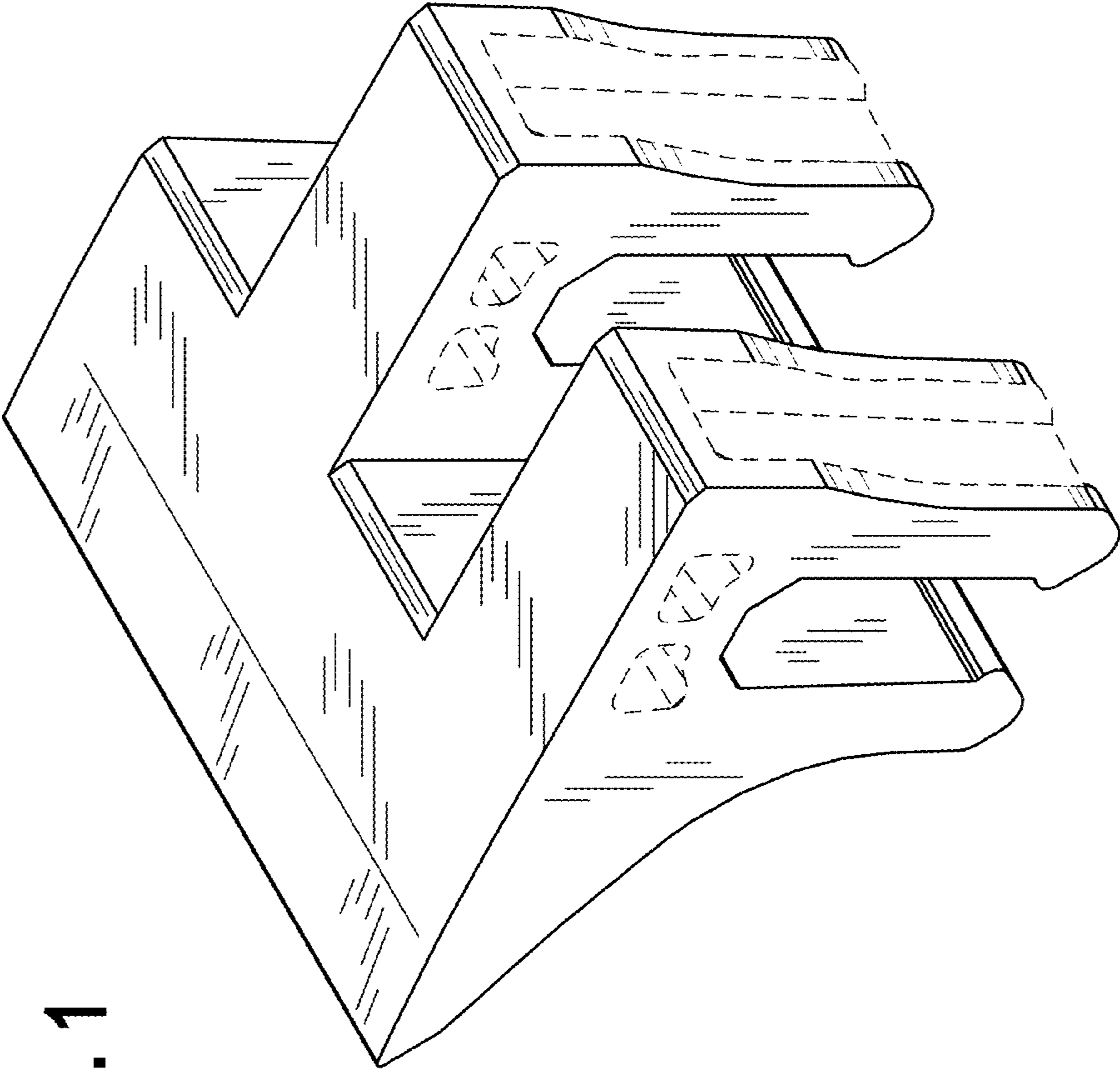

FIG. 1

FIG. 2

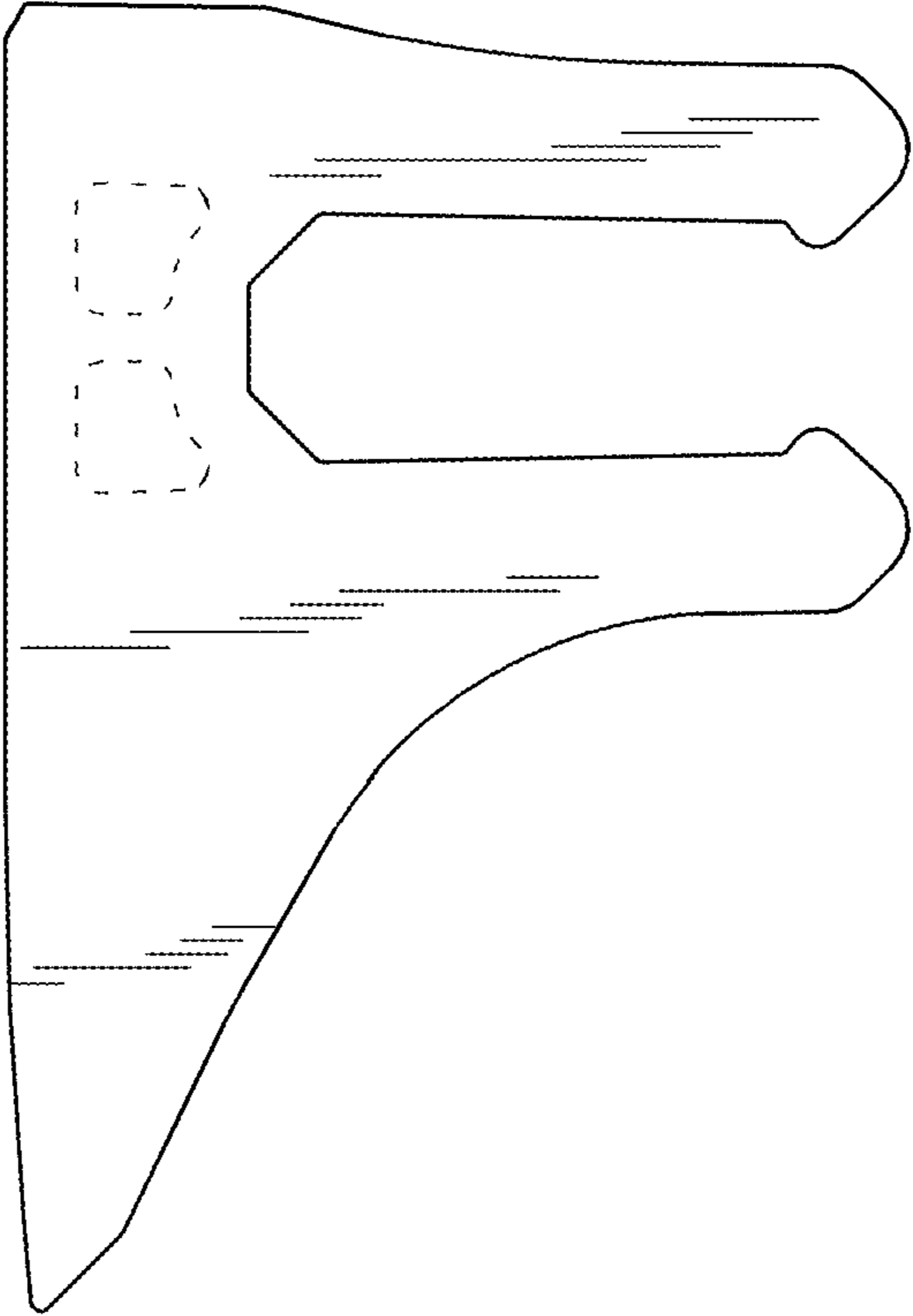

FIG. 3

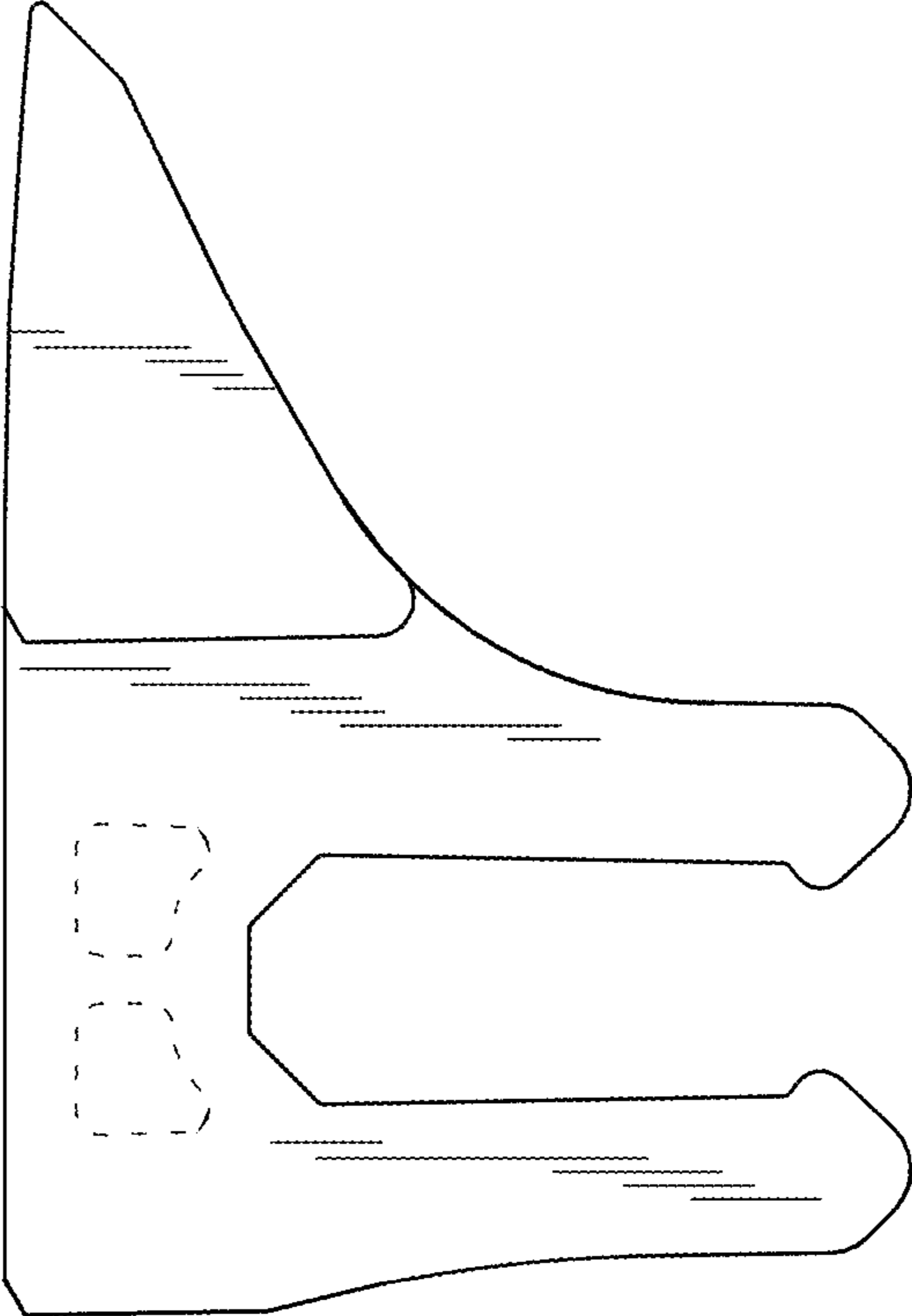

FIG. 4

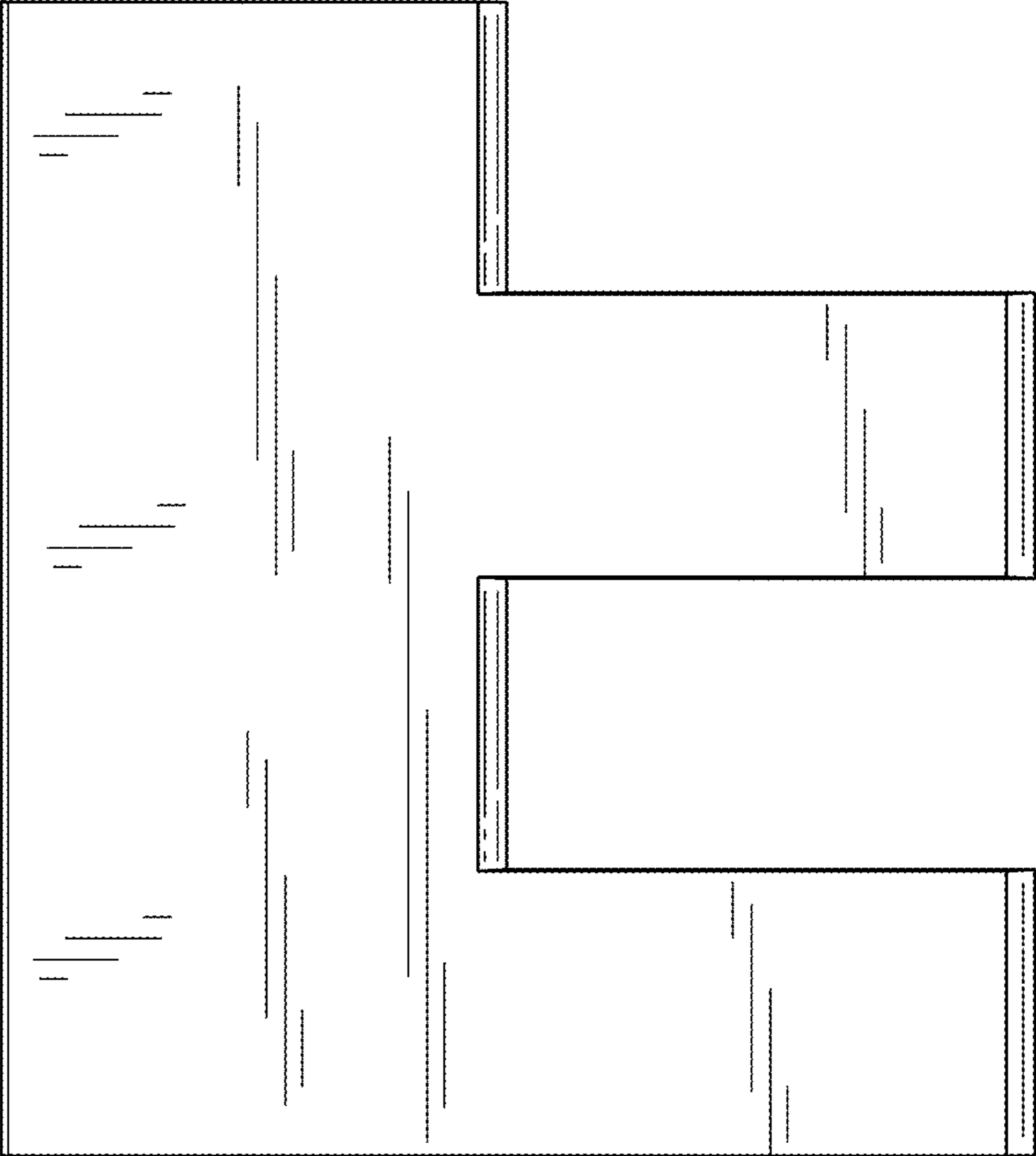

FIG. 5

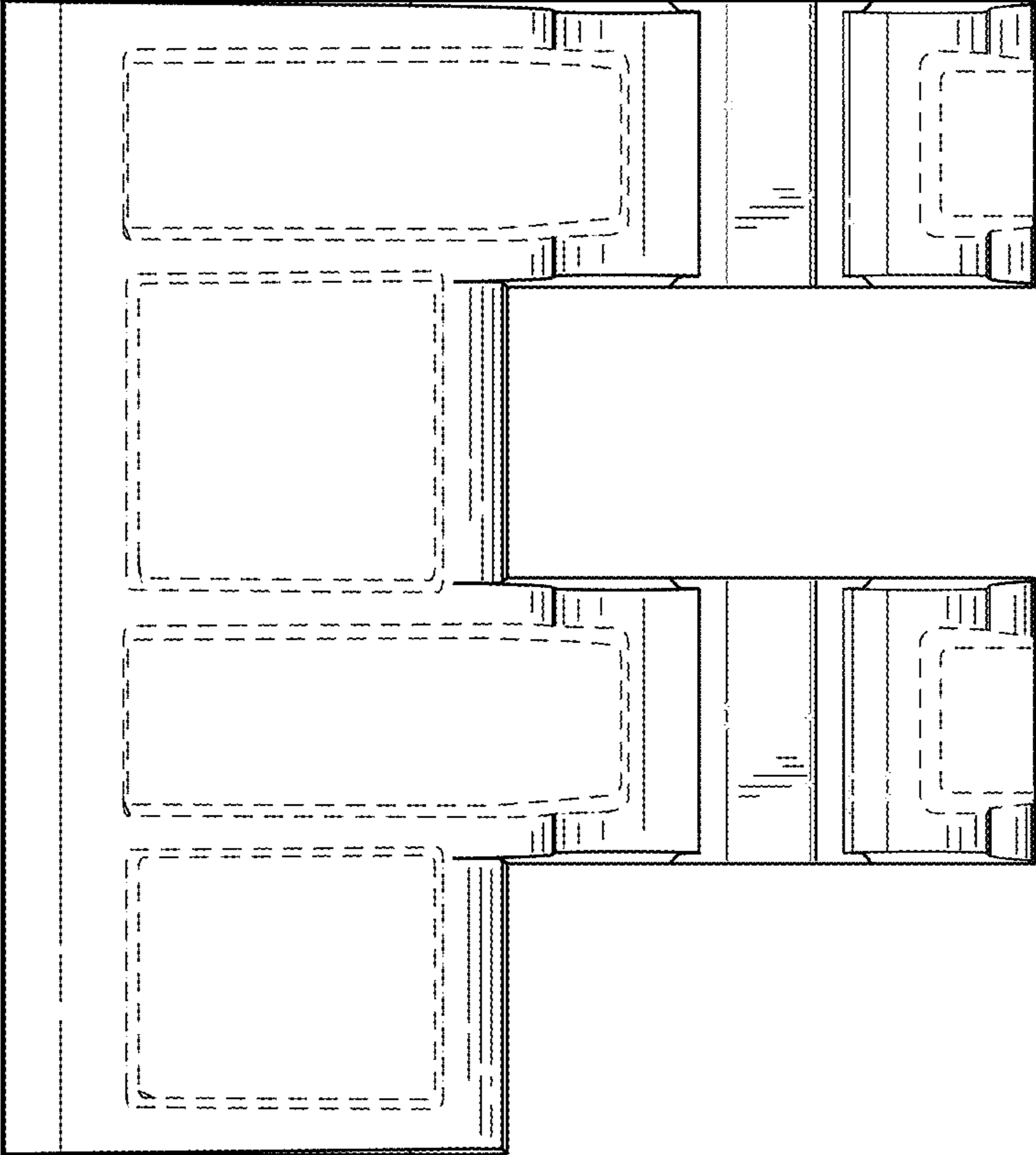

FIG. 6

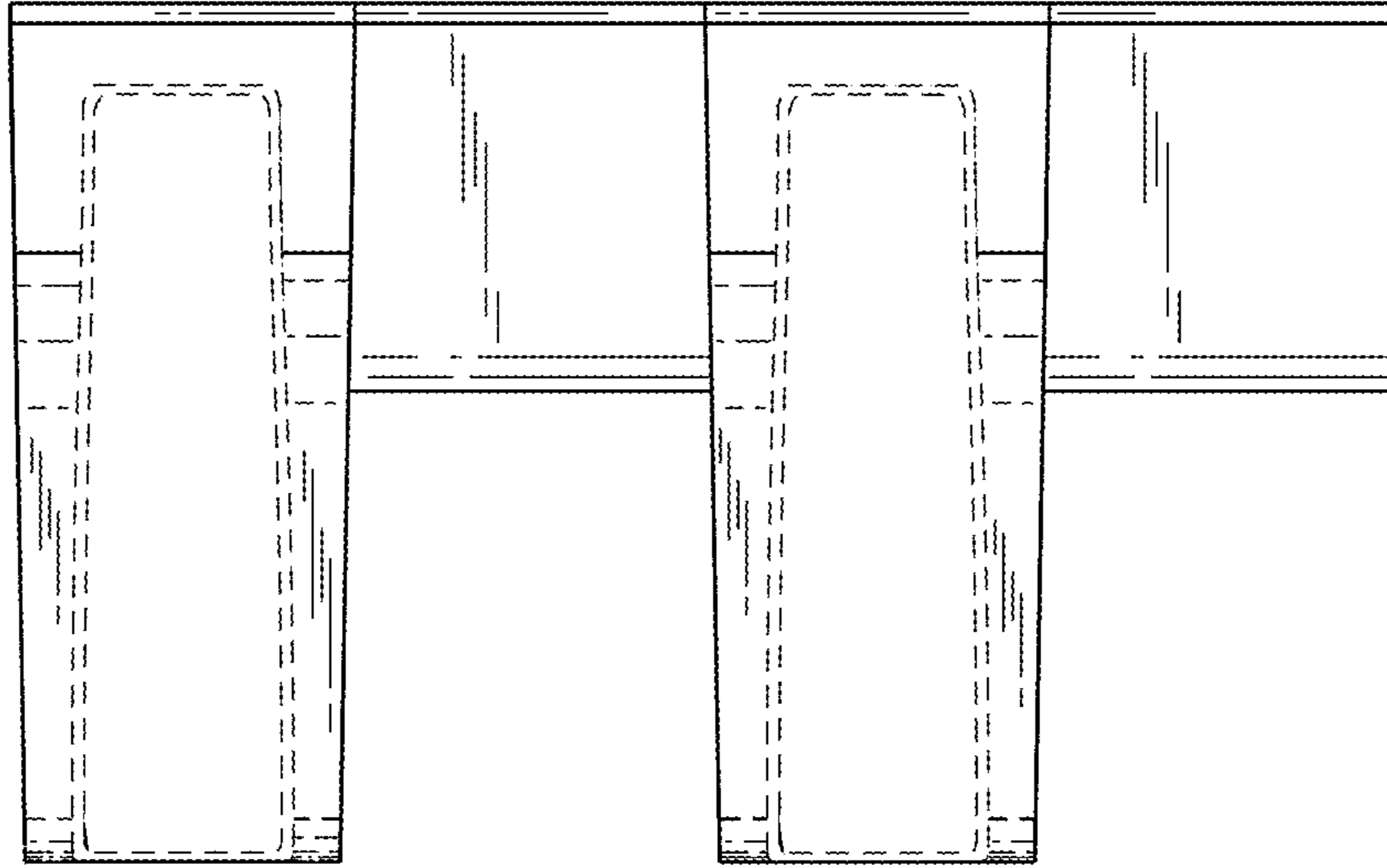

FIG. 7

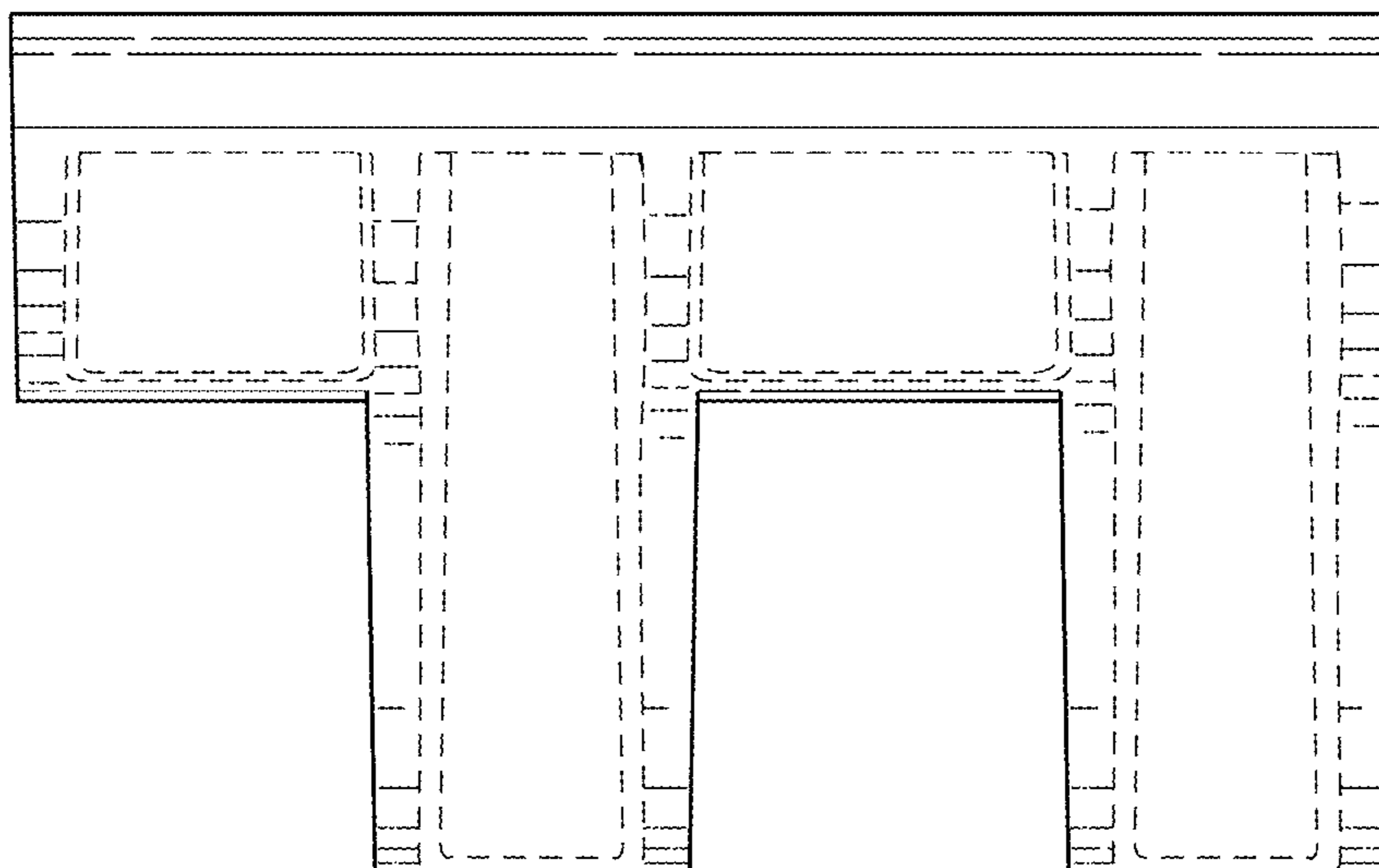

FIG. 8

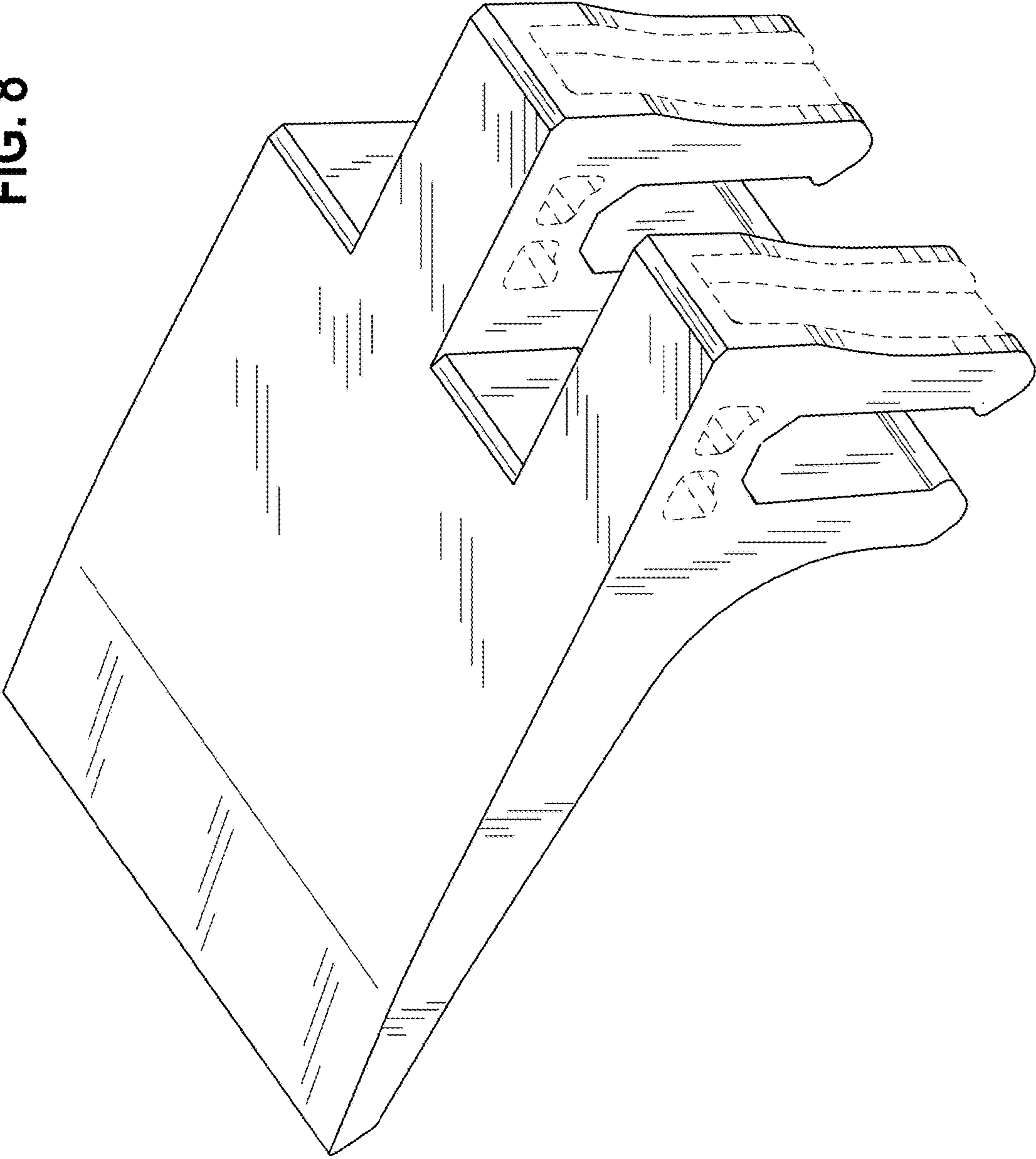

FIG. 9

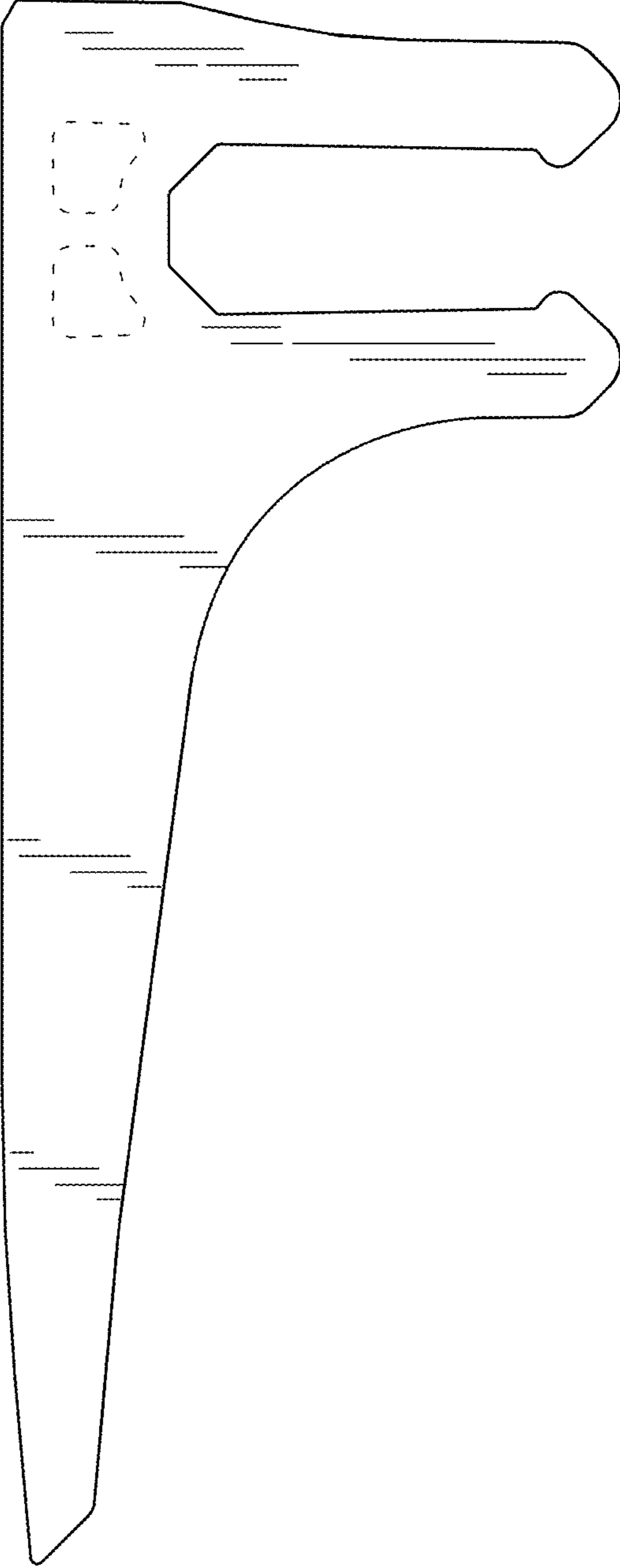

FIG. 10

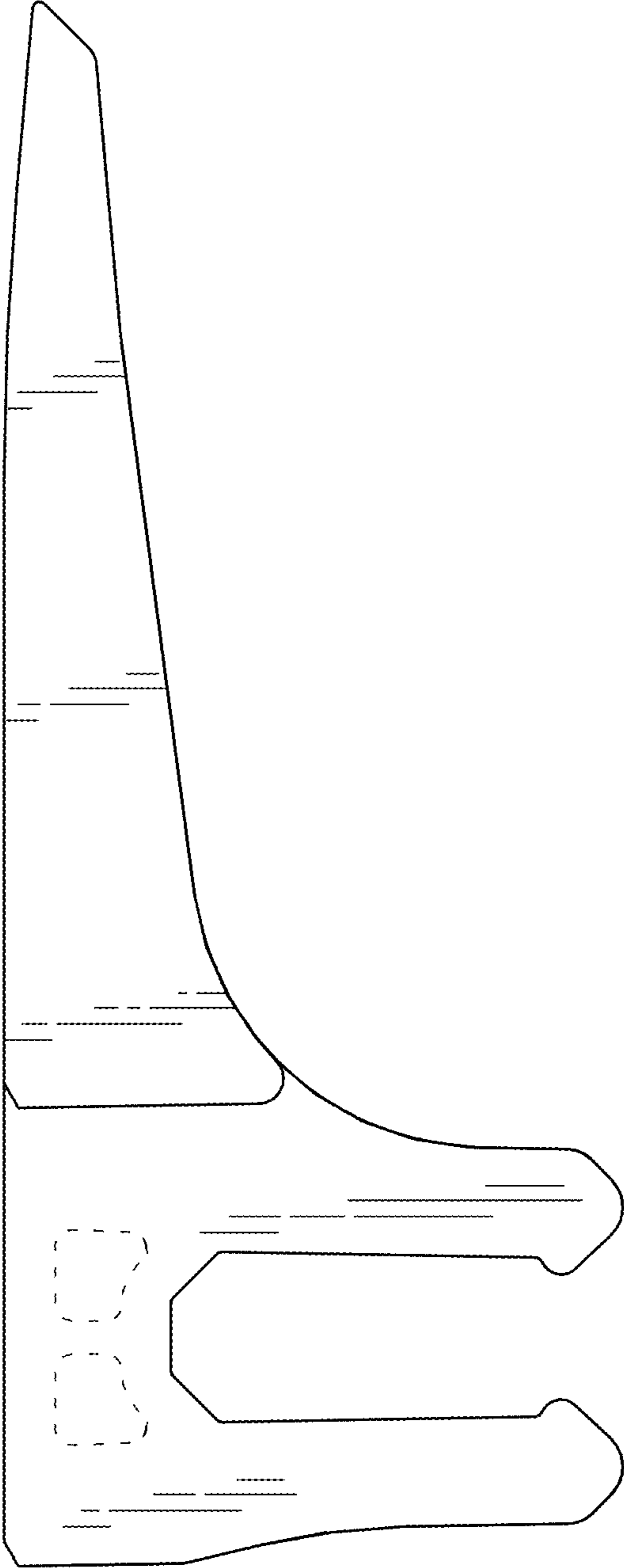

FIG. 11

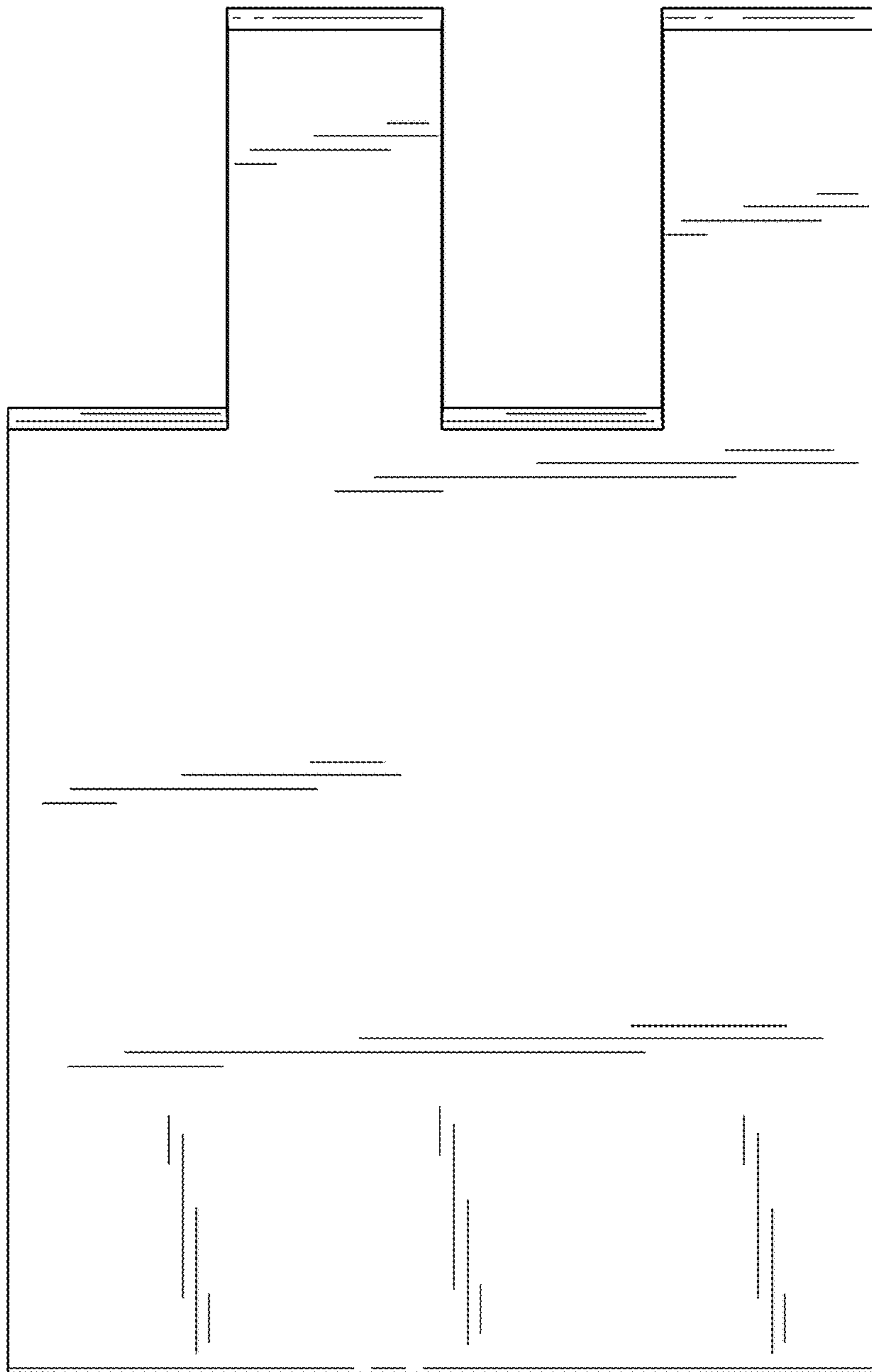

FIG. 12

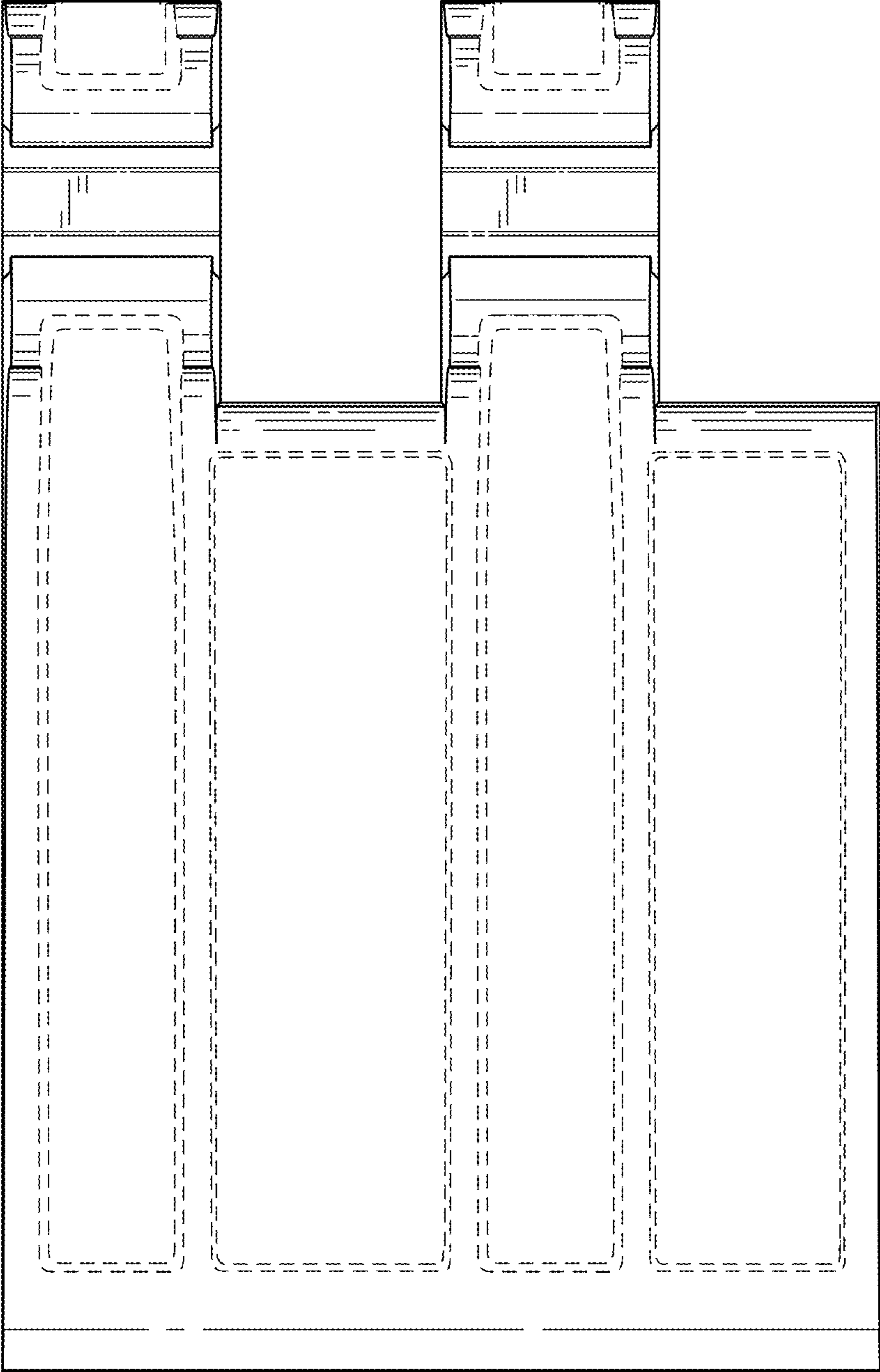

FIG. 13

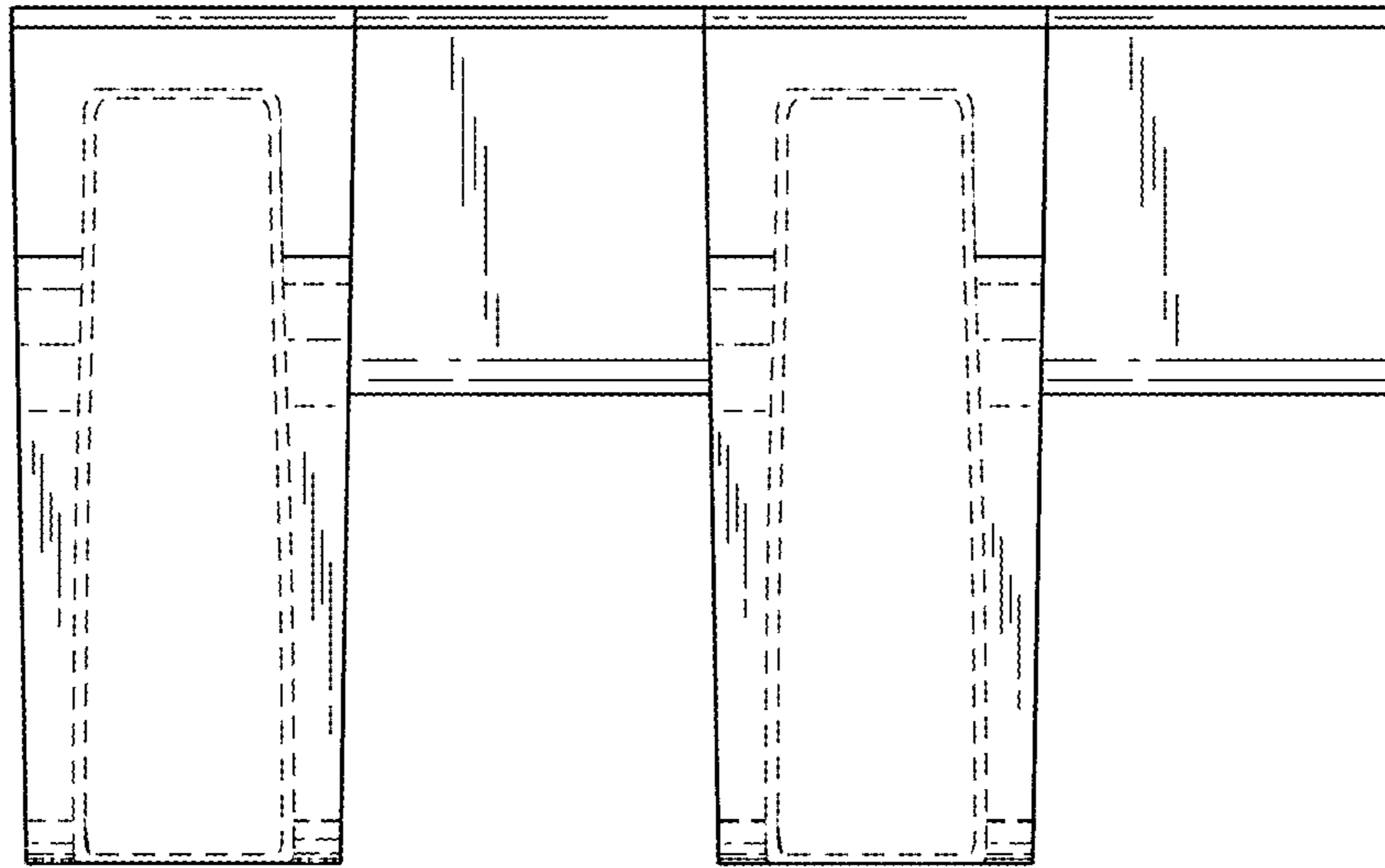

FIG. 14

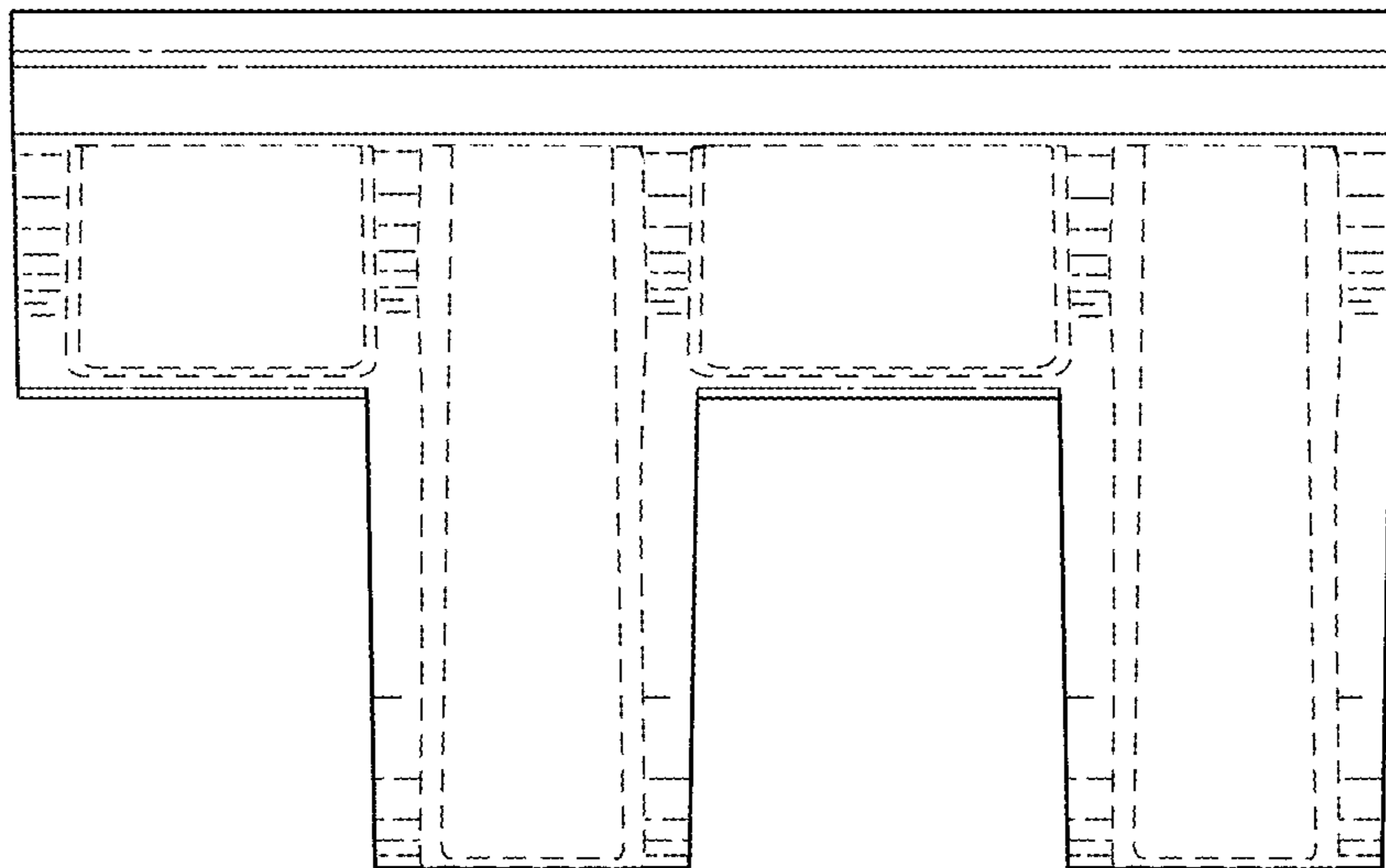

FIG. 15

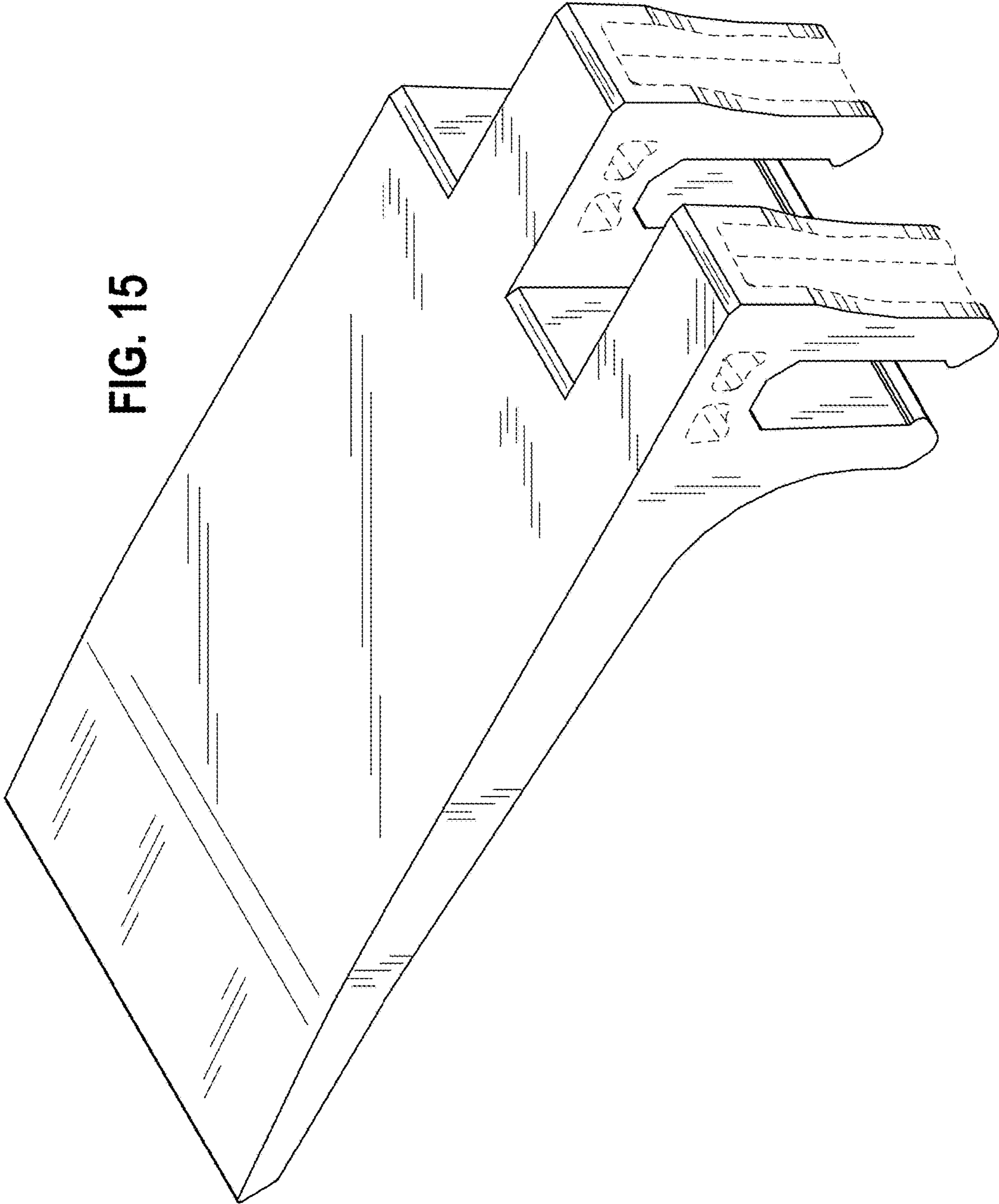

FIG. 16

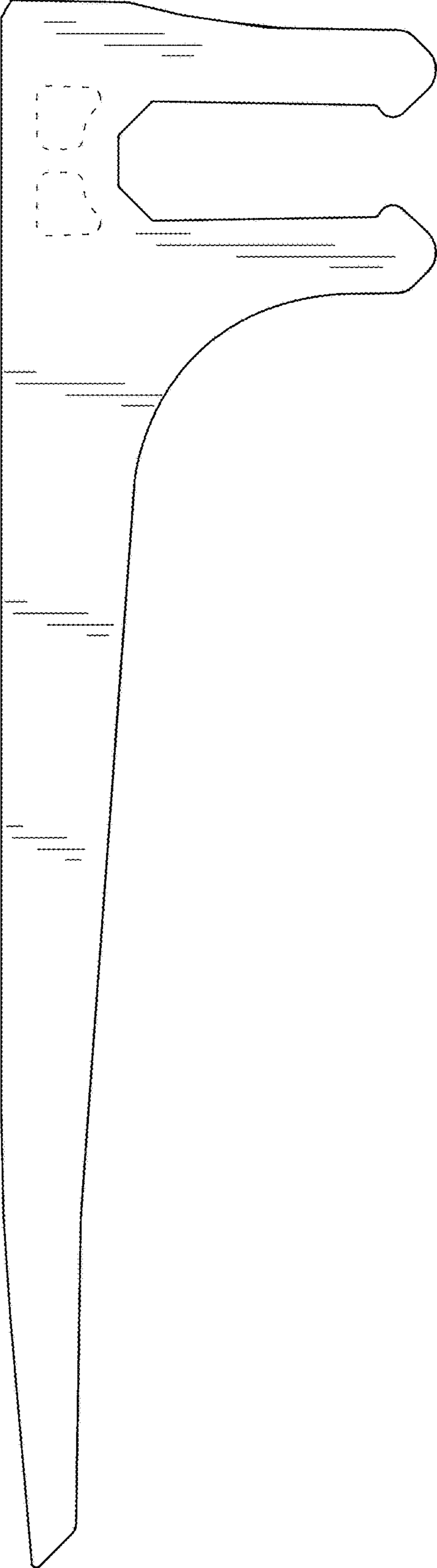

FIG. 17

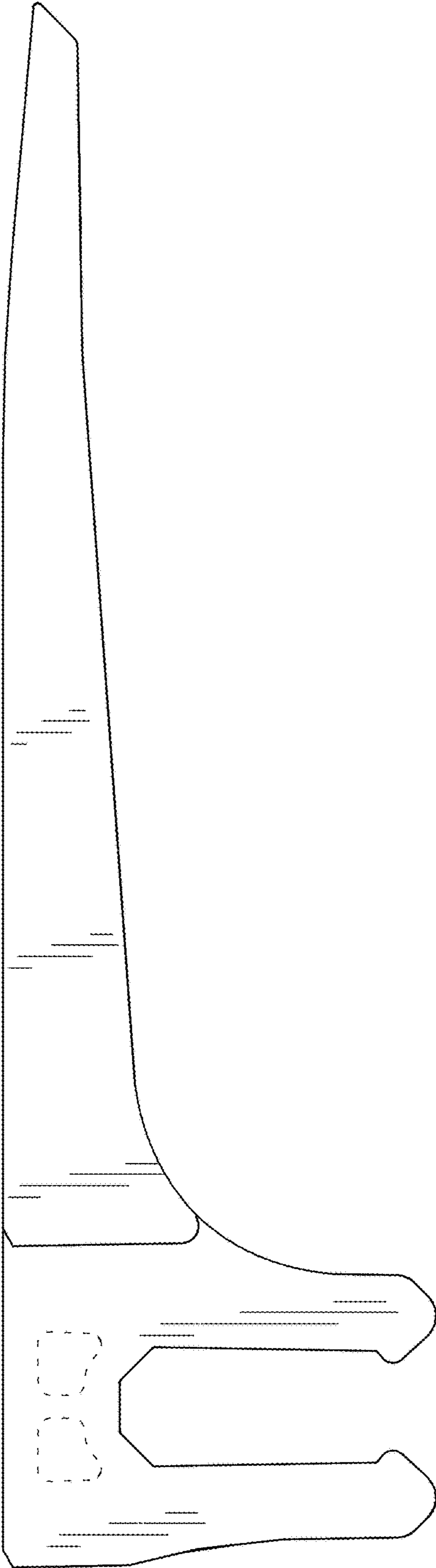

FIG. 18

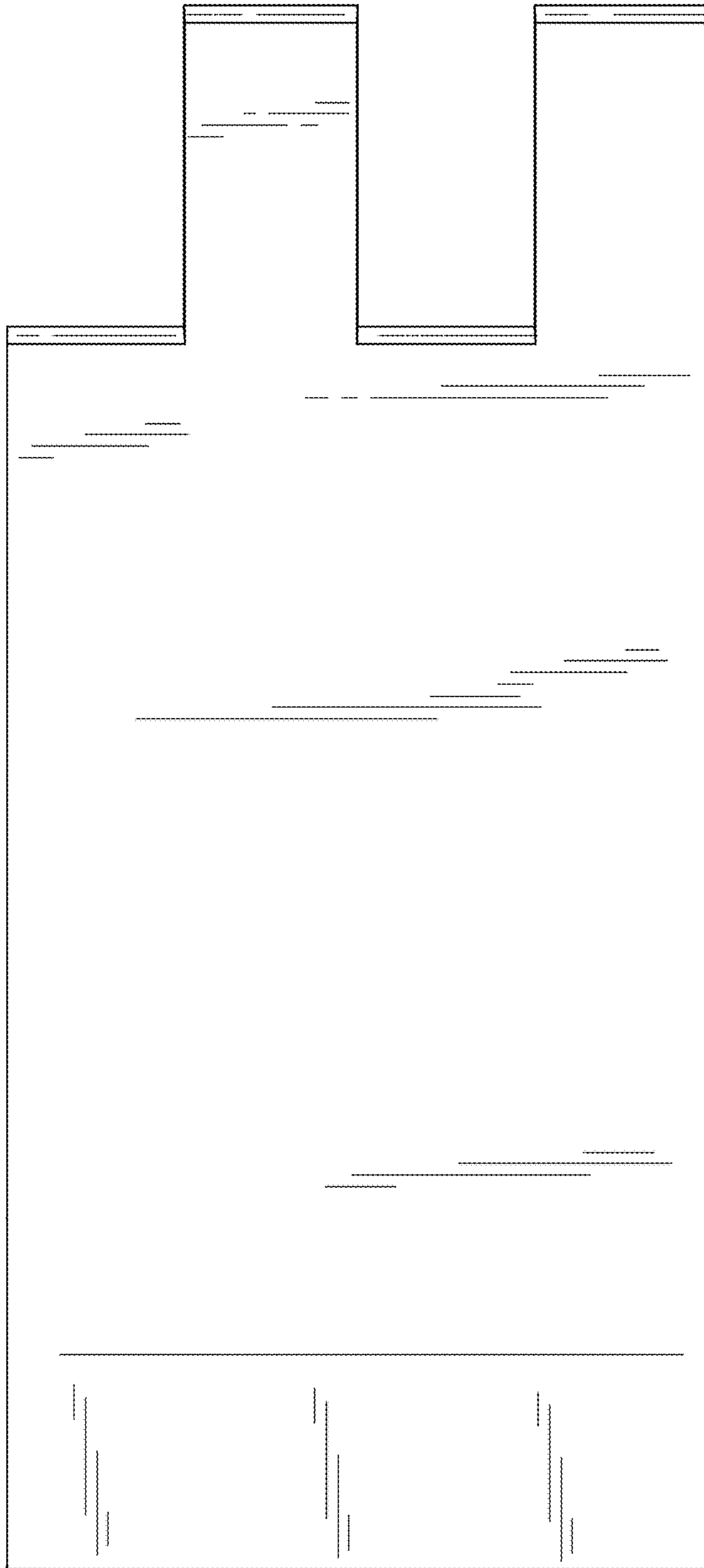

FIG. 19

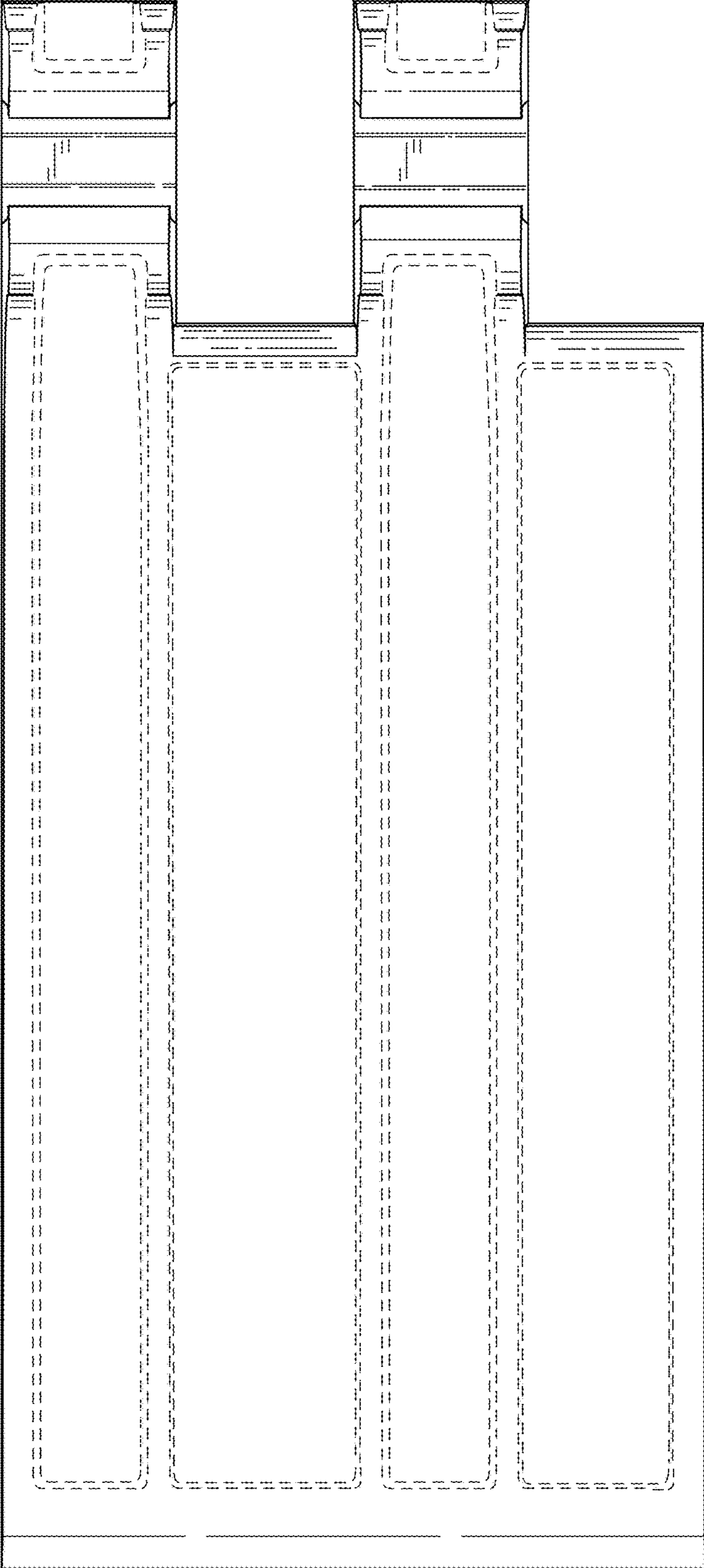

FIG. 20

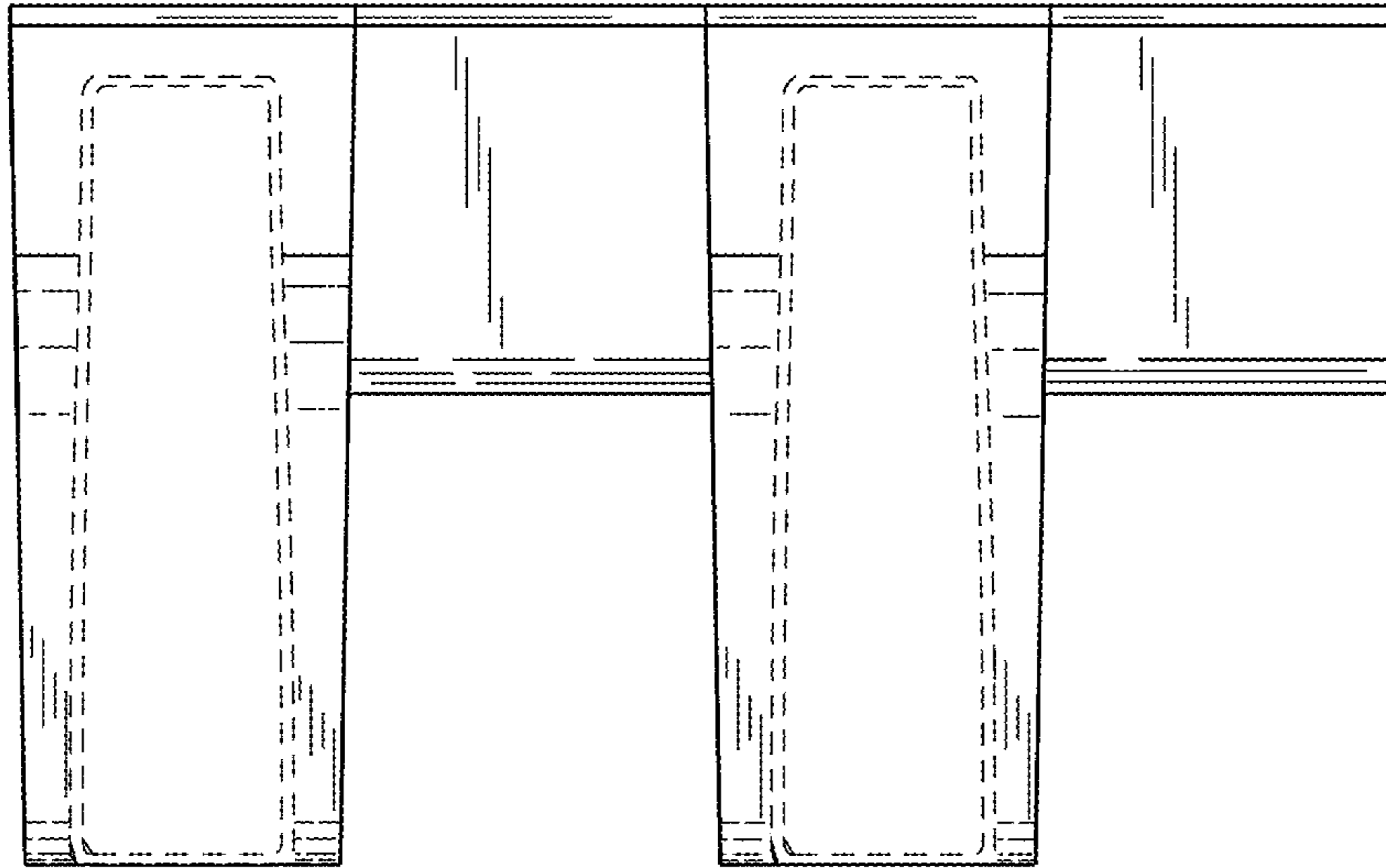

FIG. 21

