



US00D819918S

(12) **United States Design Patent**
Rowlands

(10) **Patent No.:** **US D819,918 S**
(45) **Date of Patent:** **** Jun. 5, 2018**

(54) MOTORIZED WHEELBARROW	3,323,837 A *	6/1967	Landry	B62B 1/24 298/17.5
(71) Applicant: Muck Truck UK Limited , Cornwall (GB)	D608,517 S	1/2010	Rowlands	
	9,108,609 B2	8/2015	Usui	
	9,108,690 B2 *	8/2015	Rowlands	B60L 7/003
(72) Inventor: Terry Charles Rowlands , Cornwall (GB)	D752,308 S *	3/2016	Wyse	D34/16
	D752,835 S *	3/2016	Wyse	D34/16
	D752,837 S *	3/2016	Wyse	D34/16
	D779,762 S *	2/2017	Wyse	D34/16
(73) Assignee: MUCK TRUCK UK LIMITED , Cornwall (GB)	D781,520 S *	3/2017	Chen	D34/16
	2006/0119164 A1 *	6/2006	Heskin	B60P 1/06 298/1 C

(**) Term: **15 Years**

* cited by examiner

(21) Appl. No.: **29/563,534**

Primary Examiner — Cynthia Ramirez

(22) Filed: **May 5, 2016**

Assistant Examiner — Gino Colan

(30) **Foreign Application Priority Data**

(74) *Attorney, Agent, or Firm* — Fross Zelnick Lehrman & Zissu, P.C.; Charles T. J. Weigell, Esq.

Feb. 2, 2016 (EM) 002967828

(51) **LOC (11) Cl.** **12-02**

(52) **U.S. Cl.**
USPC **D34/16**

(58) **Field of Classification Search**
USPC D34/12-25; 280/47.12, 47.31, 47.131,
280/47.17, 47.19, 47.26, 47.33; 180/19.1;
414/717; 298/17.5

CPC B62B 1/24; B62B 1/18
See application file for complete search history.

(56) **References Cited**

U.S. PATENT DOCUMENTS

2,918,133 A *	12/1959	Ericsson	B62B 1/24 180/19.1
3,021,625 A *	2/1962	Stasse	B62B 1/24 180/19.1
3,200,973 A *	8/1965	Galbraith	E02F 3/34 414/717

(57) **CLAIM**

The ornamental design for a motorized wheelbarrow, as shown and described.

DESCRIPTION

FIG. 1 is a left side elevational view of a motorized wheelbarrow showing my new design; FIG. 2 is a right side elevational view thereof; FIG. 3 is a front elevational view thereof; FIG. 4 is a back elevational view thereof; FIG. 5 is a top plan view thereof; FIG. 6 is a left side elevational view thereof, with the bed shown in a raised position; and, FIG. 7 is a top plan view thereof, with the bed shown in a raised position.

The broken lines in the drawings illustrate the portions of the motorized wheelbarrow that form no part of the claimed design.

1 Claim, 7 Drawing Sheets

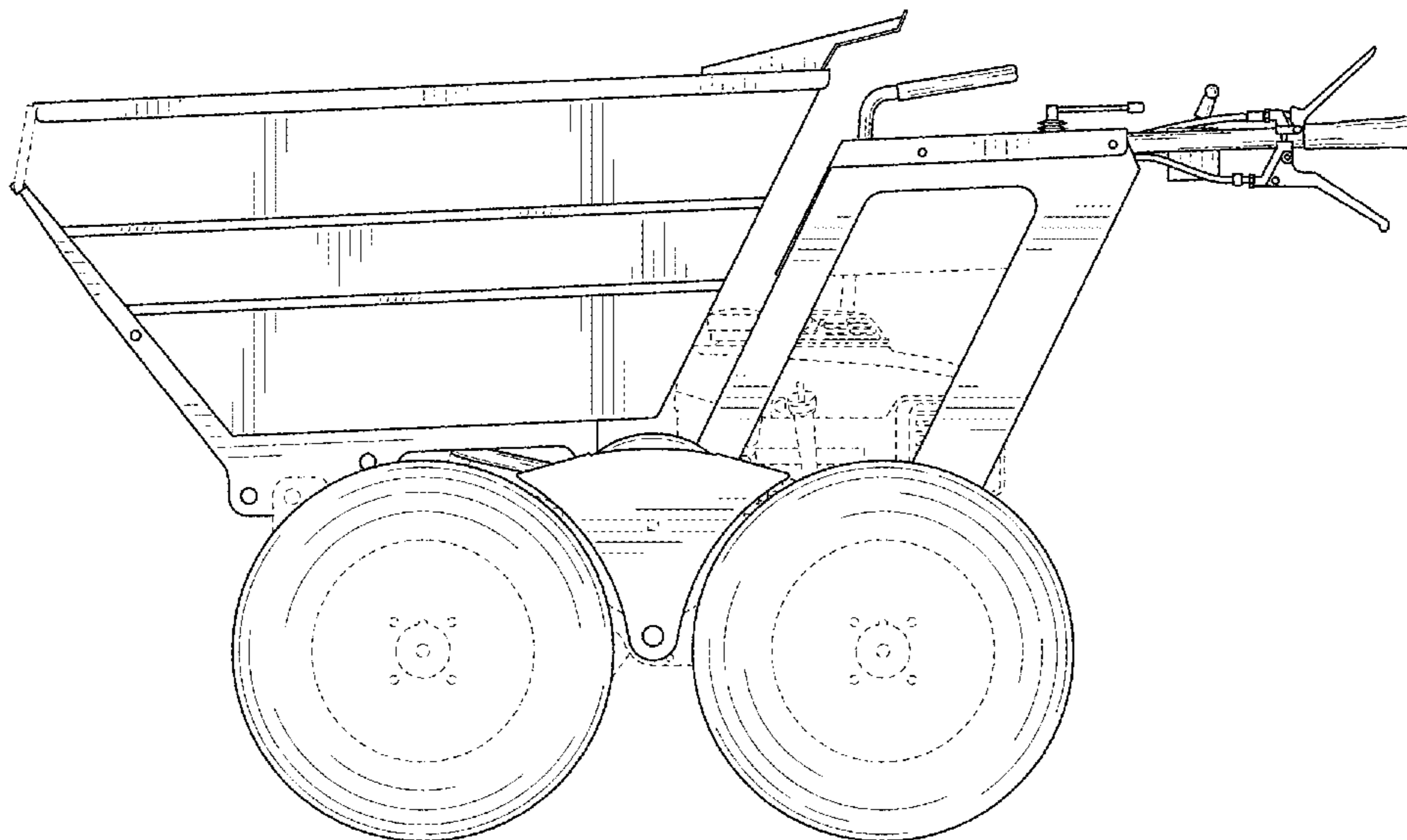

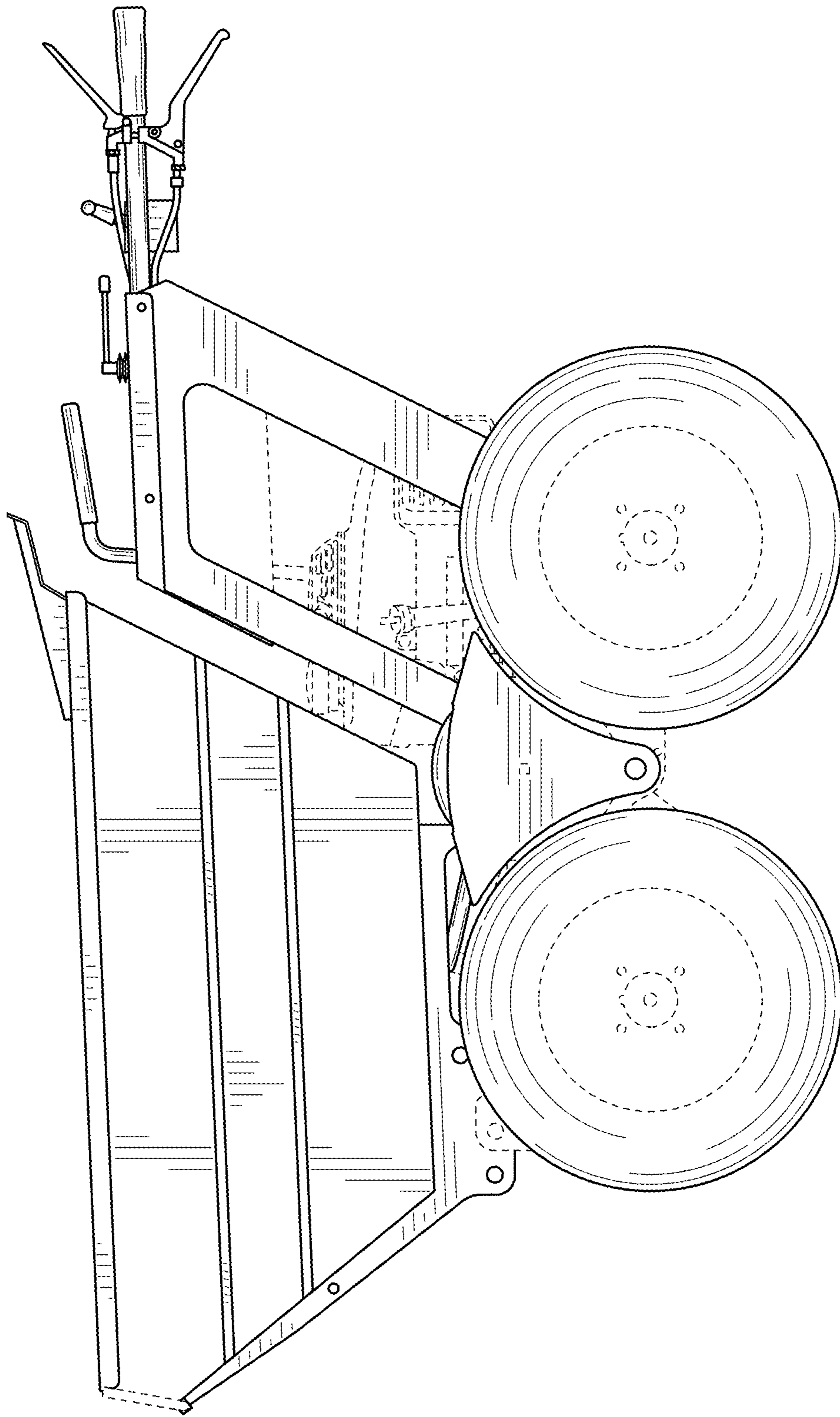

FIG. 1

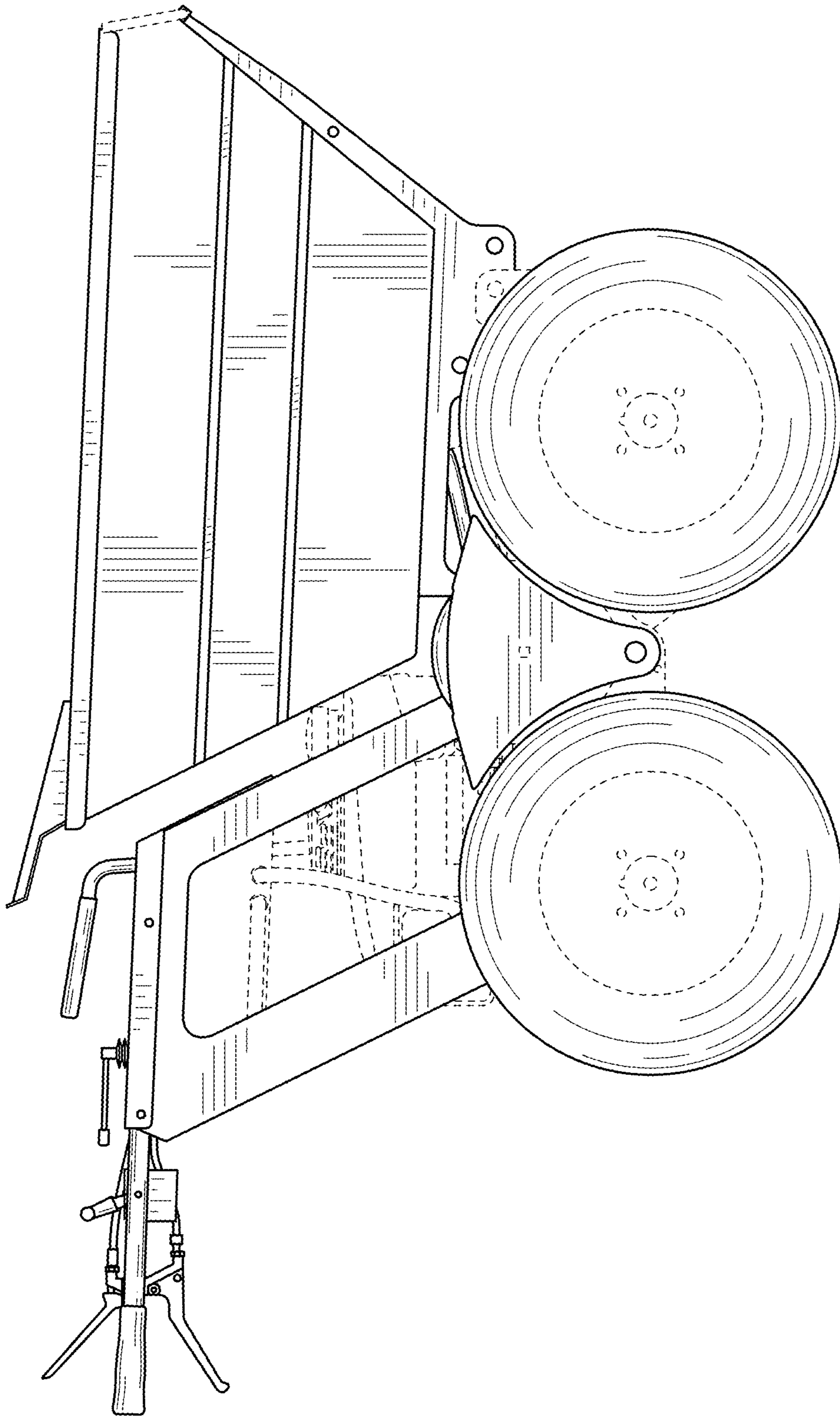

FIG. 2

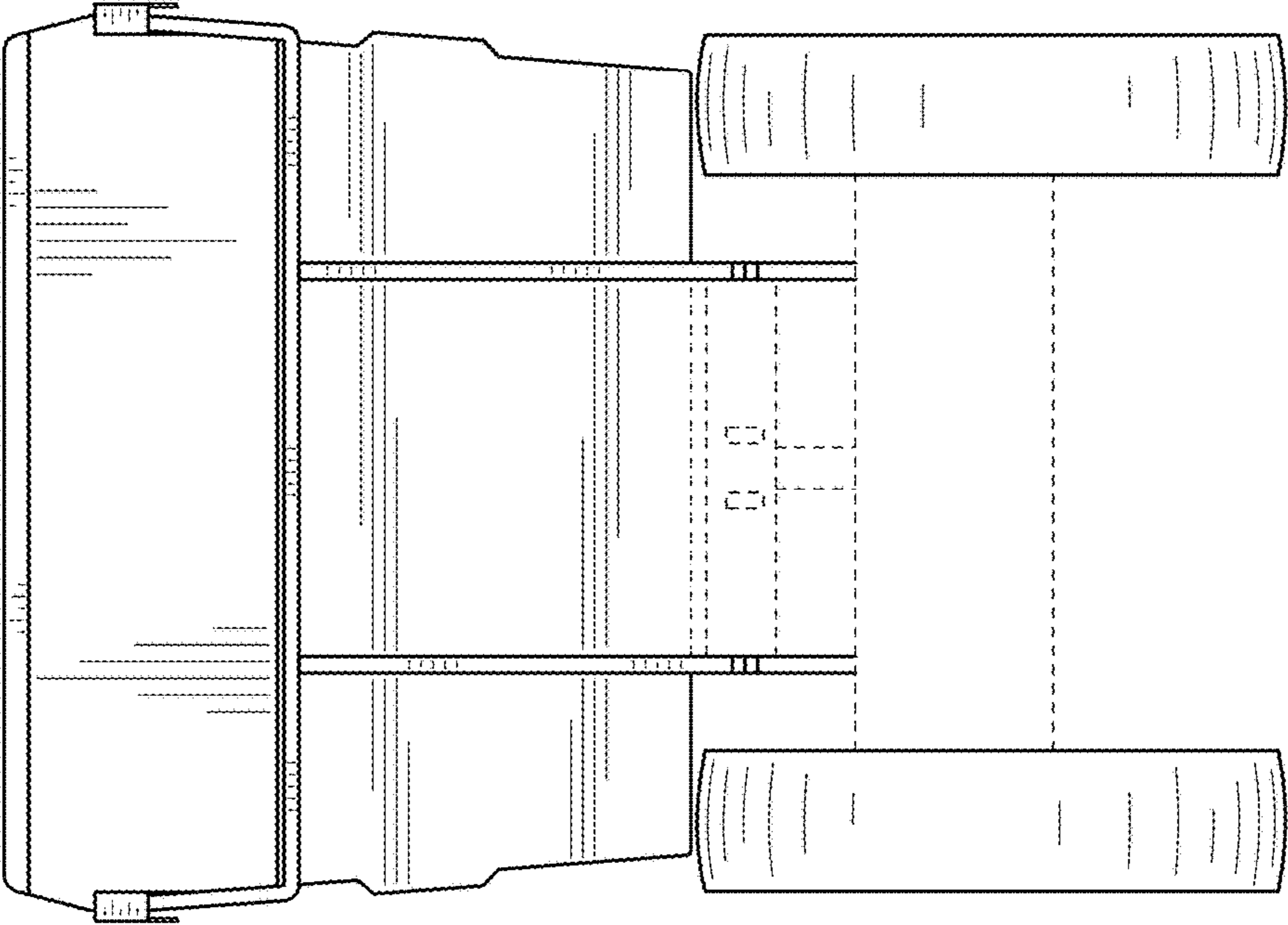

FIG. 3

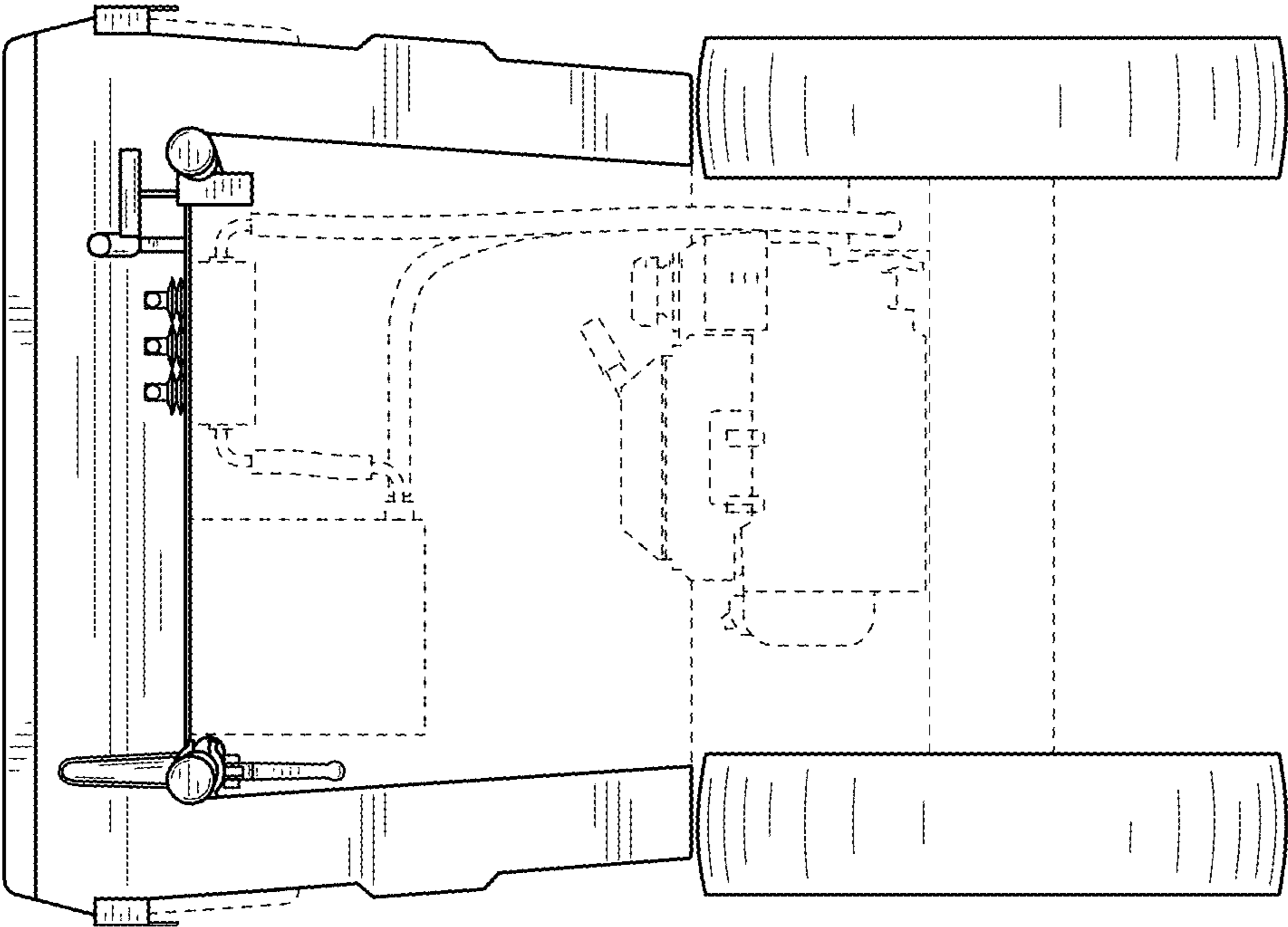

FIG. 4

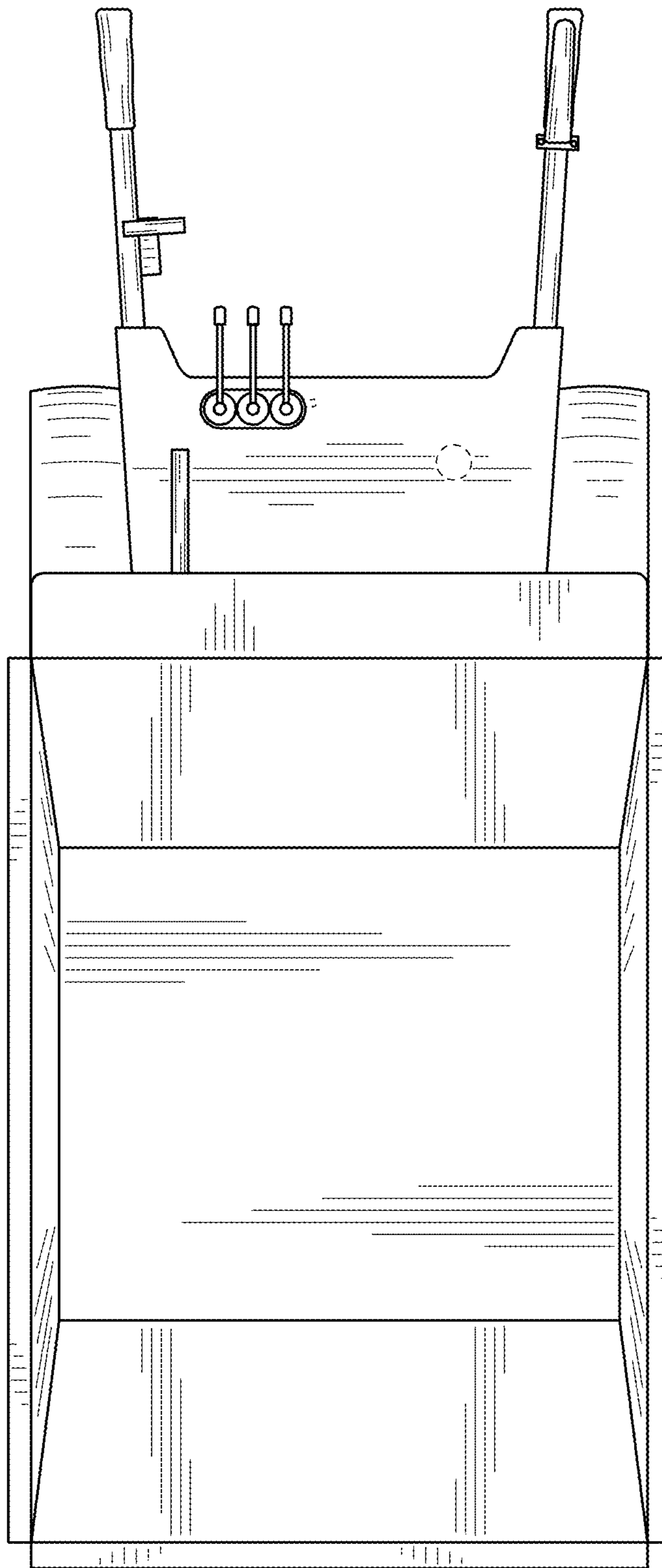

FIG. 5

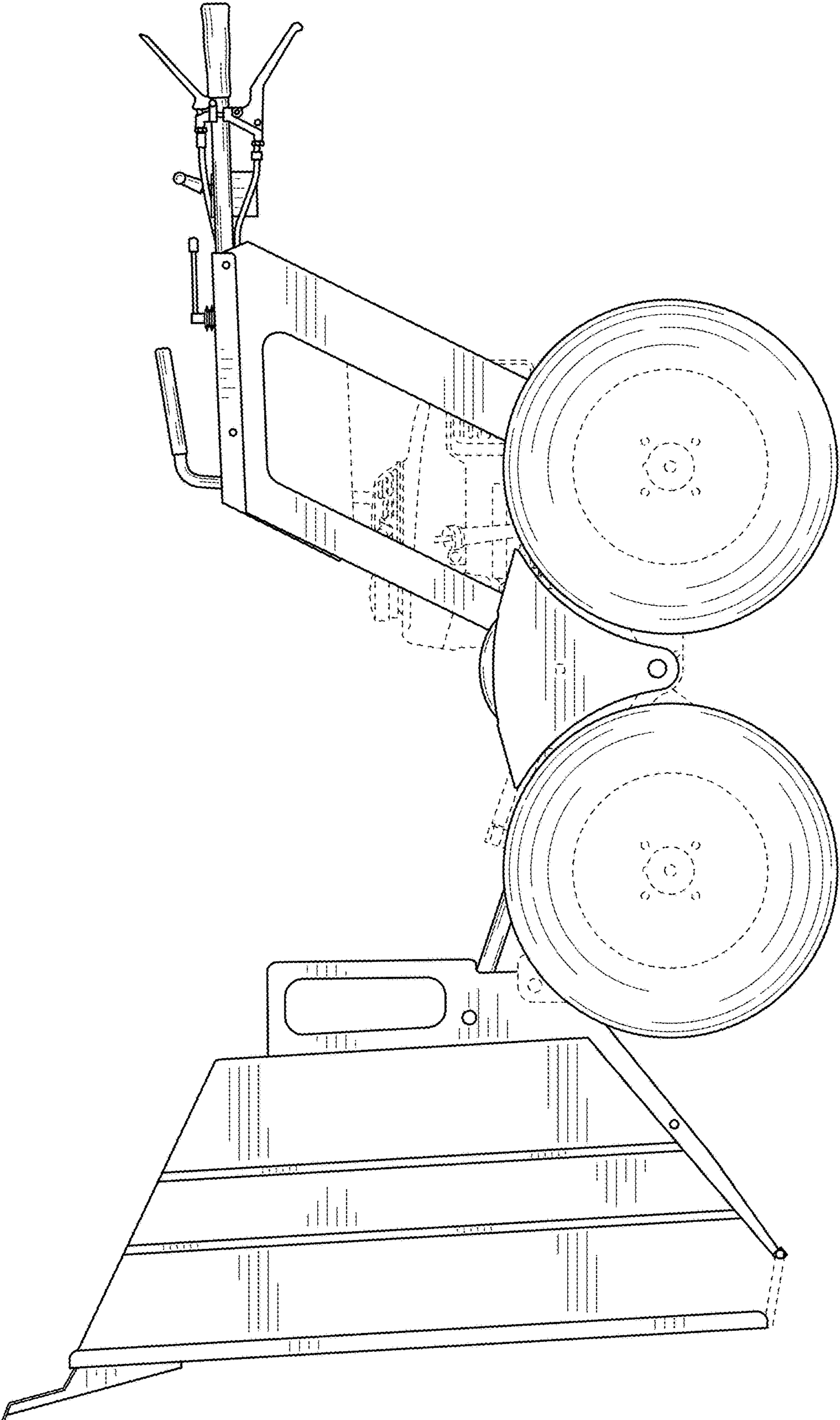

FIG. 6

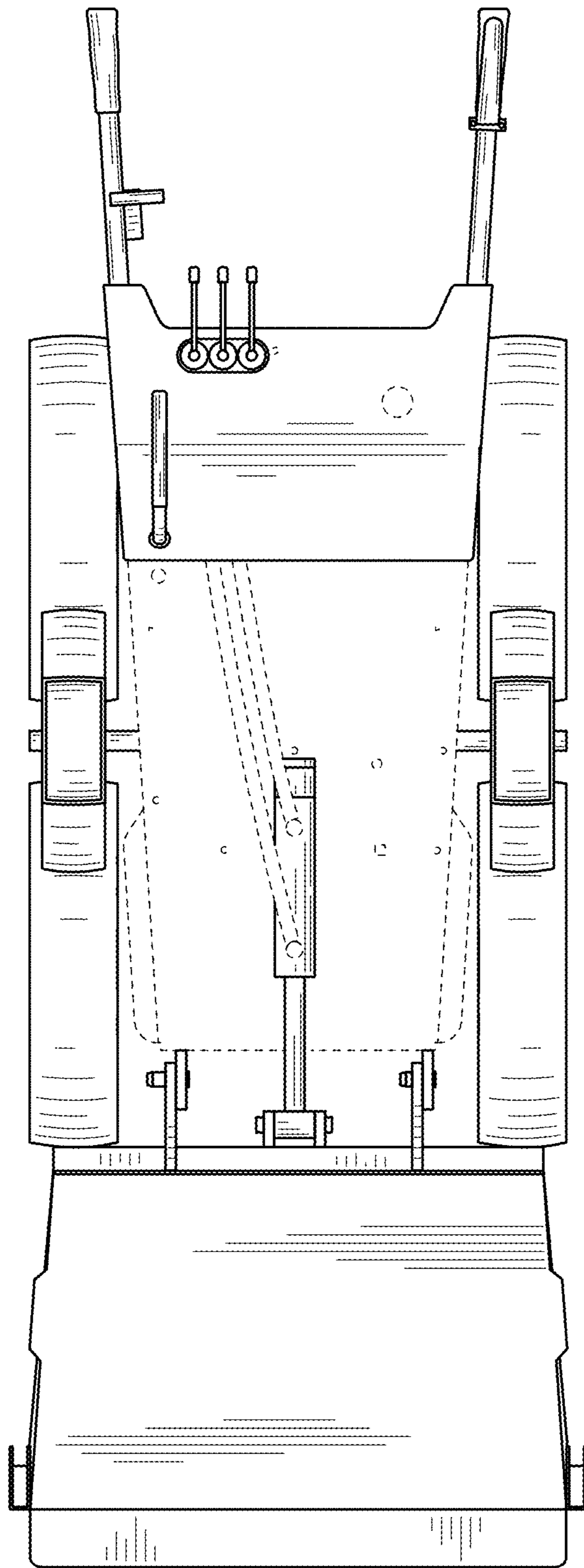

FIG. 7