



US00D819561S

(12) **United States Design Patent** (10) **Patent No.:** **US D819,561 S**  
**Wang et al.** (45) **Date of Patent:** **\*\* Jun. 5, 2018**

(54) **BATTERY** D756,915 S \* 5/2016 Yang ..... D13/108  
D766,821 S \* 9/2016 Chan ..... D13/107  
D780,116 S \* 2/2017 Bing ..... D13/107  
(Continued)

(71) Applicant: **SZ DJI Technology Co., Ltd.**,  
Shenzhen (CN)

(72) Inventors: **Zhen Wang**, Shenzhen (CN); **Yun Zhao**, Shenzhen (CN); **Shaojie Chen**,  
Shenzhen (CN)

(73) Assignee: **SZ DJI Technology Co., Ltd.**,  
Shenzhen (CN)

**FOREIGN PATENT DOCUMENTS**

CN 3106518 3/1999  
CN 3141346 3/2000  
CN 3151149 6/2000

(Continued)

(\*\*) Term: **15 Years**

(21) Appl. No.: **29/579,394**

(22) Filed: **Sep. 29, 2016**

(51) **LOC (11) Cl.** ..... **13-02**

(52) **U.S. Cl.**  
USPC ..... **D13/103**

(58) **Field of Classification Search**  
USPC ..... D13/102–106, 110, 118–119, 184  
CPC ..... Y02E 60/12; Y02E 60/122; Y02E 60/124;  
Y02E 60/50; H01M 2/02; H01M 2/022;  
H01M 2/0202; H01M 2/0207; H01M  
2/0212; H01M 2/1061; H01M 2/1022;  
H01M 2/1055; H01M 2/1066; H01M  
2/105; H01M 2/204; H01M 10/4257;  
H01M 10/0436; H01M 10/48

See application file for complete search history.

(56) **References Cited**

**U.S. PATENT DOCUMENTS**

D383,725 S 9/1997 Settsu  
D648,270 S \* 11/2011 Jiang ..... D13/103  
D678,187 S \* 3/2013 Huang ..... D13/103  
D693,297 S \* 11/2013 Inskeep ..... D13/103  
D704,135 S \* 5/2014 Stewart ..... D13/108  
D713,786 S \* 9/2014 Wen ..... D13/103  
D738,822 S \* 9/2015 Stewart ..... D13/108  
D740,749 S \* 10/2015 Stewart ..... D13/108  
D743,886 S \* 11/2015 Nomi ..... D13/108

**OTHER PUBLICATIONS**

DJI TB50 Intelligent Flight Battery, DJI, first available on amazon.com Nov. 18, 2016, retrieved on Oct. 15, 2017, retrieved from the Internet URL: [https://www.amazon.com/DJI-Intelligent-Flight-Battery-Inspire/dp/B01N9C5ZSC/ref=sr\\_1\\_1?ie=UTF8&qid=1508101865&sr=8-1&keywords=DJI=TB50=Intelligent=Flight=Battery.\\*](https://www.amazon.com/DJI-Intelligent-Flight-Battery-Inspire/dp/B01N9C5ZSC/ref=sr_1_1?ie=UTF8&qid=1508101865&sr=8-1&keywords=DJI=TB50=Intelligent=Flight=Battery.*)

*Primary Examiner* — Rosemary K Tarcza  
*Assistant Examiner* — Alison M Ofstun  
(74) *Attorney, Agent, or Firm* — Sterne, Kessler,  
Goldstein & Fox P.L.L.C.

(57) **CLAIM**

The ornamental design for a battery, as shown and described.

**DESCRIPTION**

FIG. 1 is a top front perspective view of a battery showing the claimed design;  
FIG. 2 is a bottom front perspective view thereof;  
FIG. 3 is a bottom rear perspective view thereof;  
FIG. 4 is a left side view thereof;  
FIG. 5 is a right side view thereof;  
FIG. 6 is a bottom view thereof;  
FIG. 7 is a top view thereof;  
FIG. 8 is a front view thereof; and,  
FIG. 9 is a rear view thereof.  
The broken lines in the figures show portions of the battery that form no part of the claimed design.

**1 Claim, 7 Drawing Sheets**

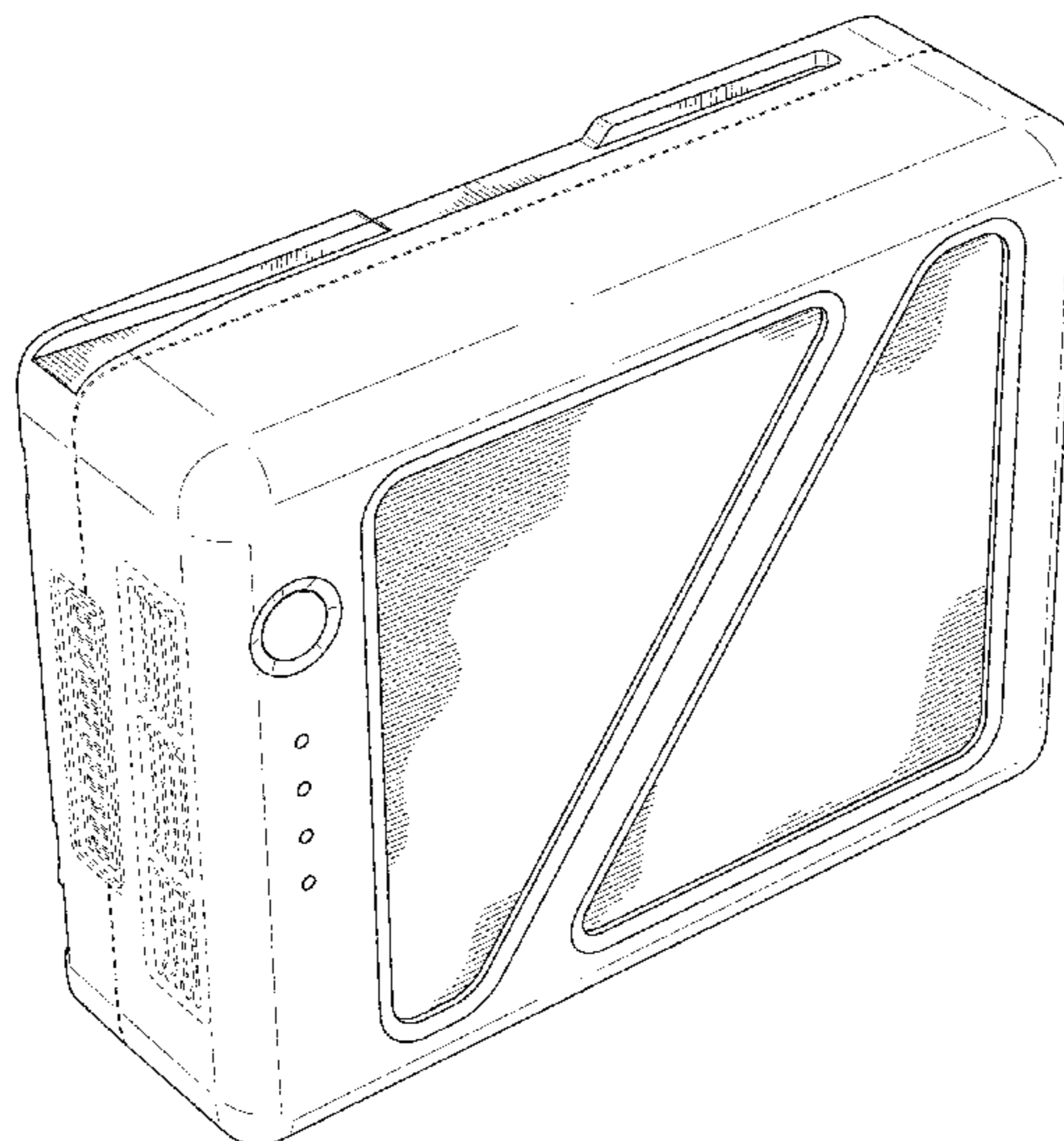

(56)

**References Cited**

U.S. PATENT DOCUMENTS

D796,432 S \* 9/2017 Liu ..... D13/107  
2014/0335919 A1\* 11/2014 Stewart ..... H02J 7/0042  
455/573

FOREIGN PATENT DOCUMENTS

CN	3262561	11/2002
CN	3590841	12/2006
CN	300935895	6/2009
CN	302143027 S	10/2012
CN	302671698 S	12/2013
CN	303622732 S	3/2016
JP	D1200696 S	3/2004
JP	D1230436 S	2/2005
JP	D1402061 S	11/2010
JP	D1440989 S	5/2012

\* cited by examiner

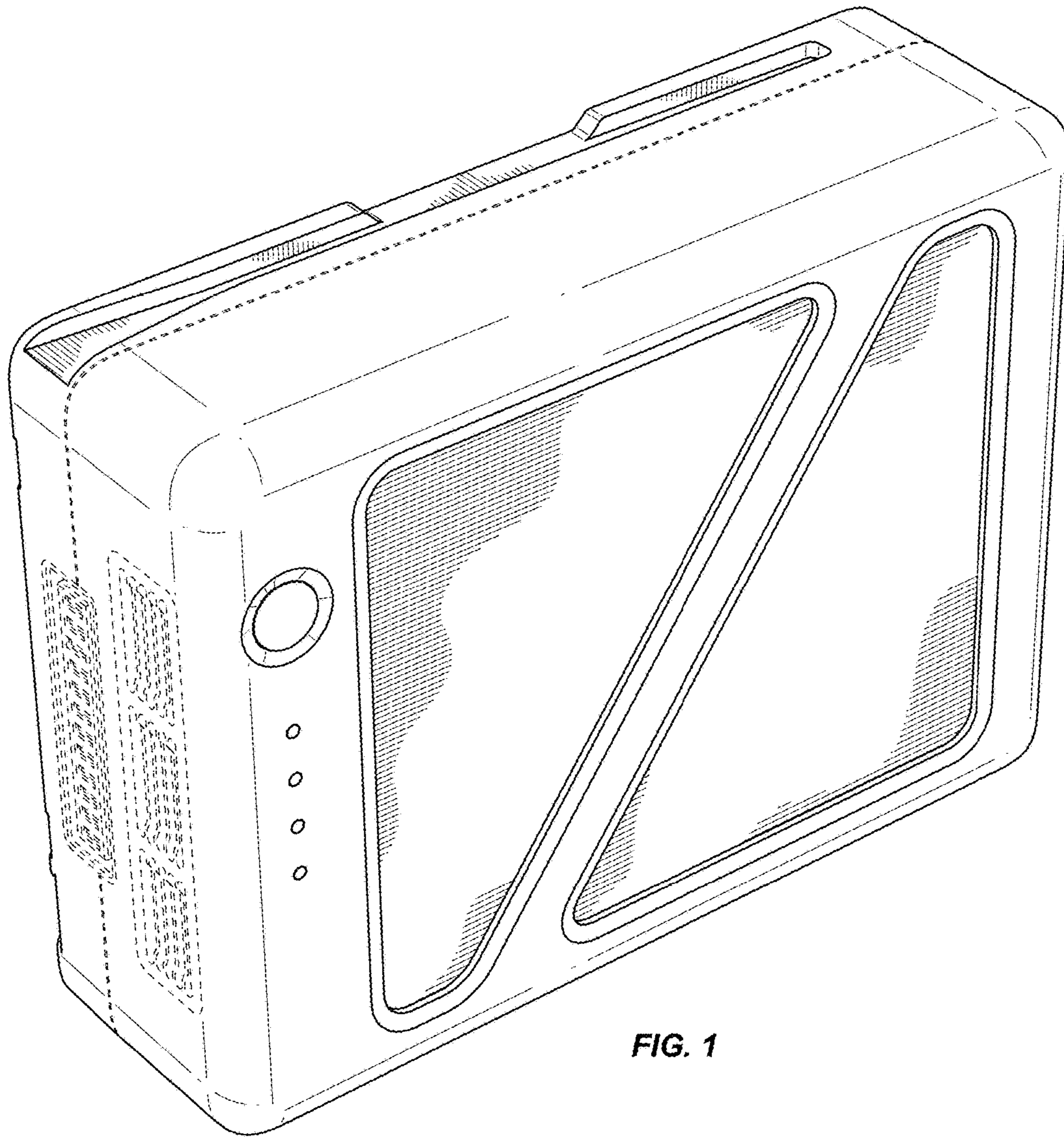

FIG. 1



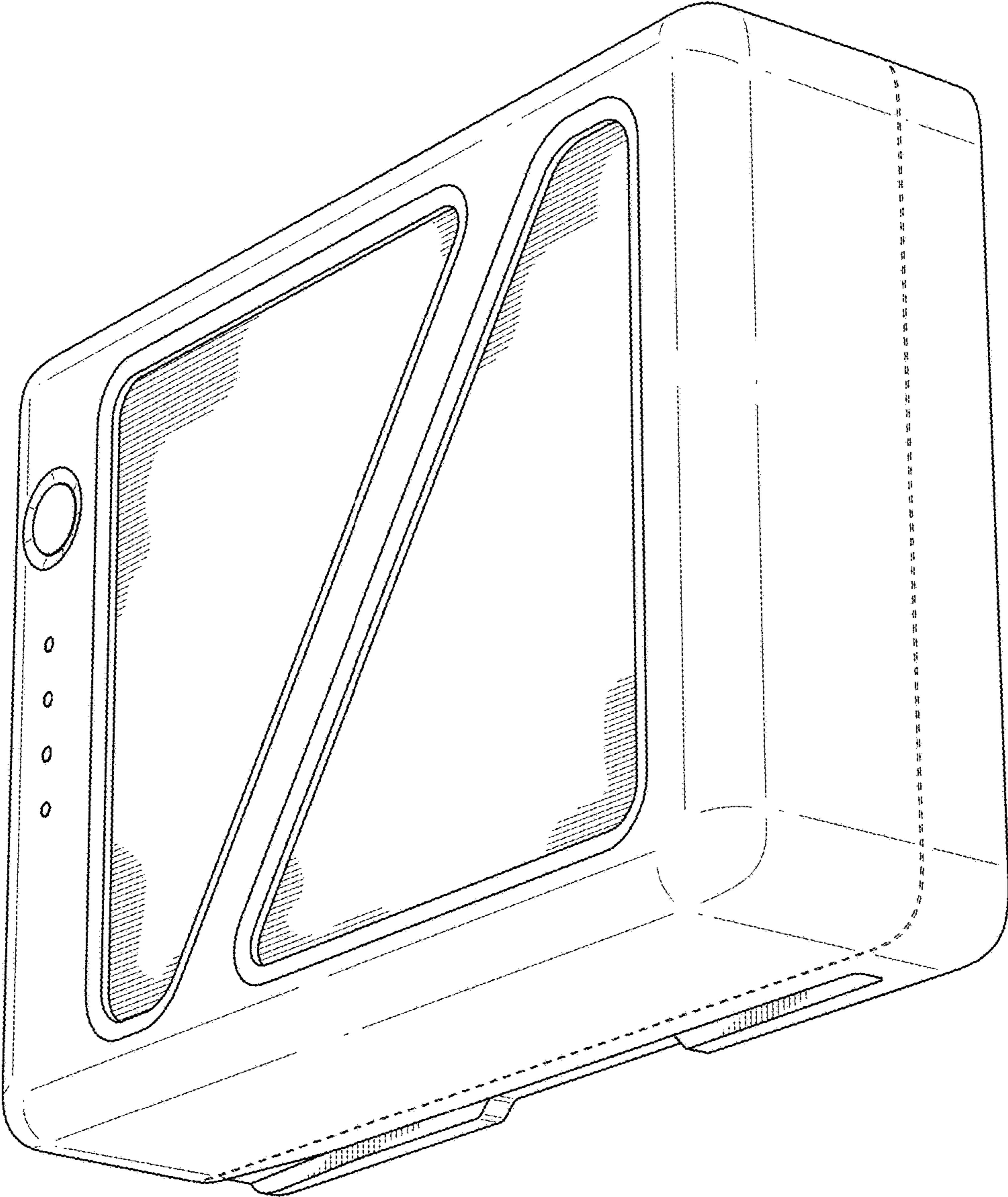

FIG. 2

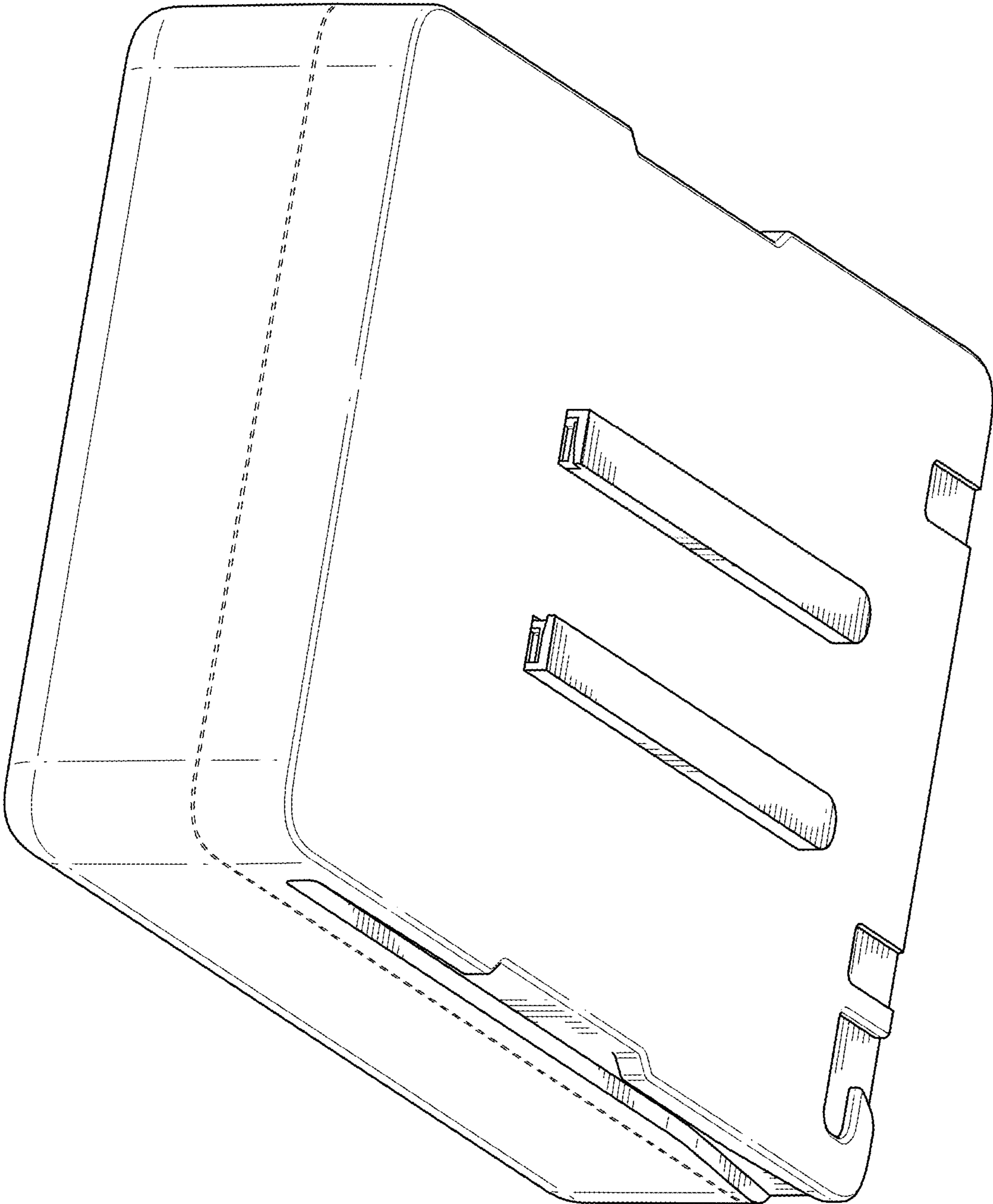

FIG. 3

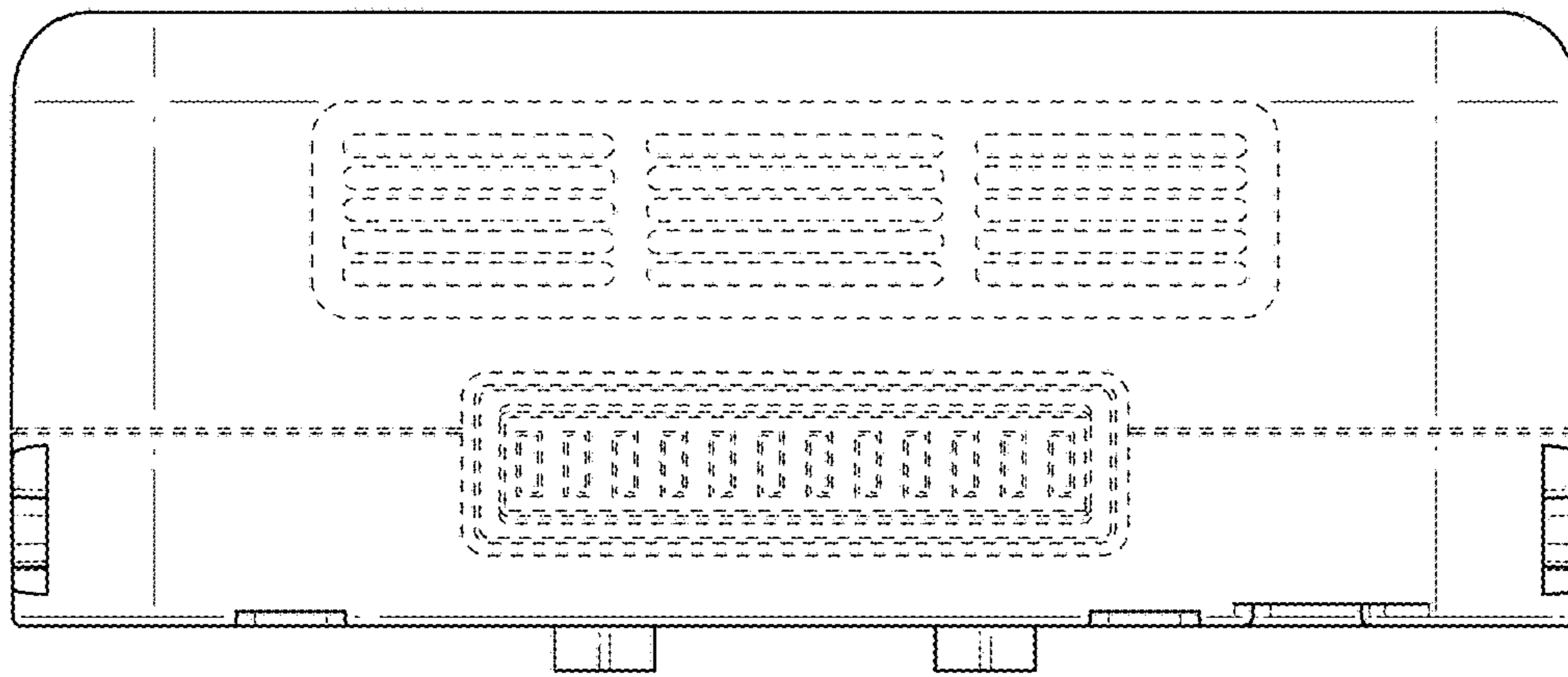

FIG. 4

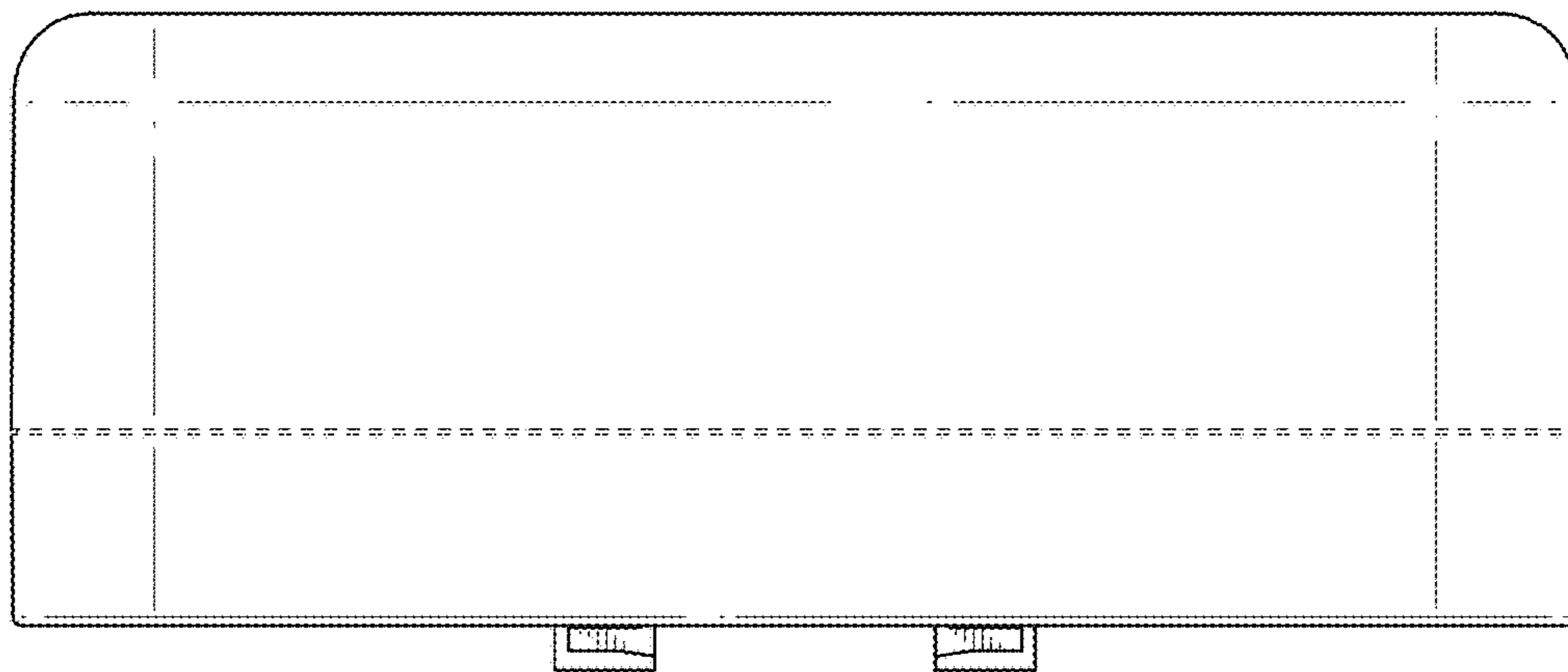

FIG. 5

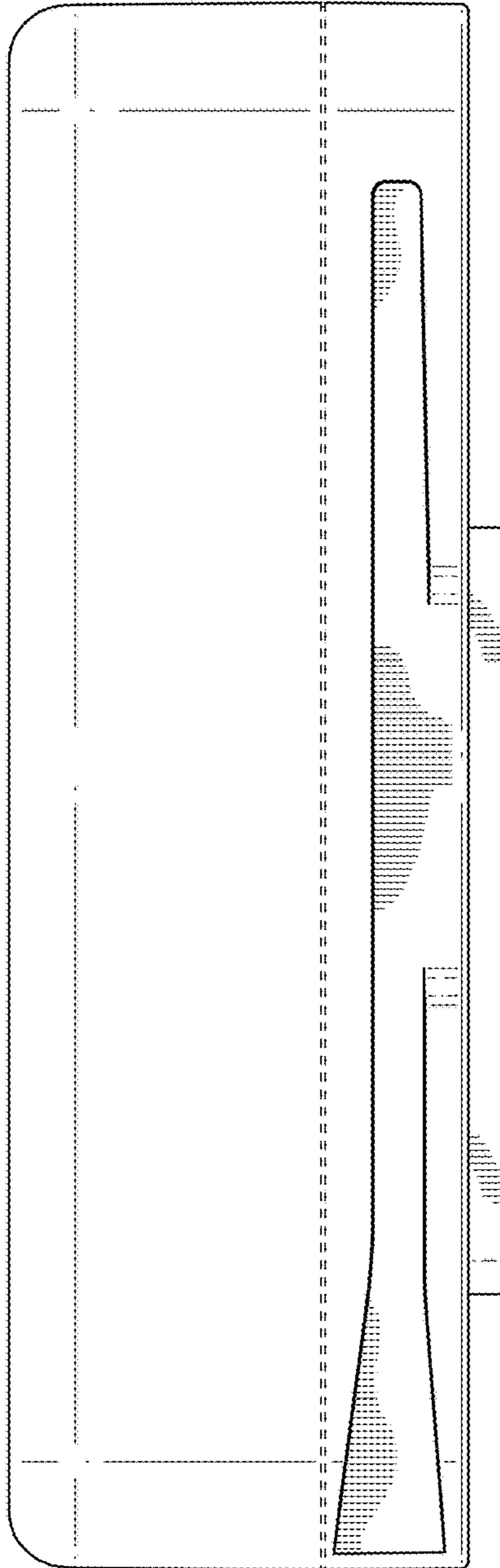

FIG. 6

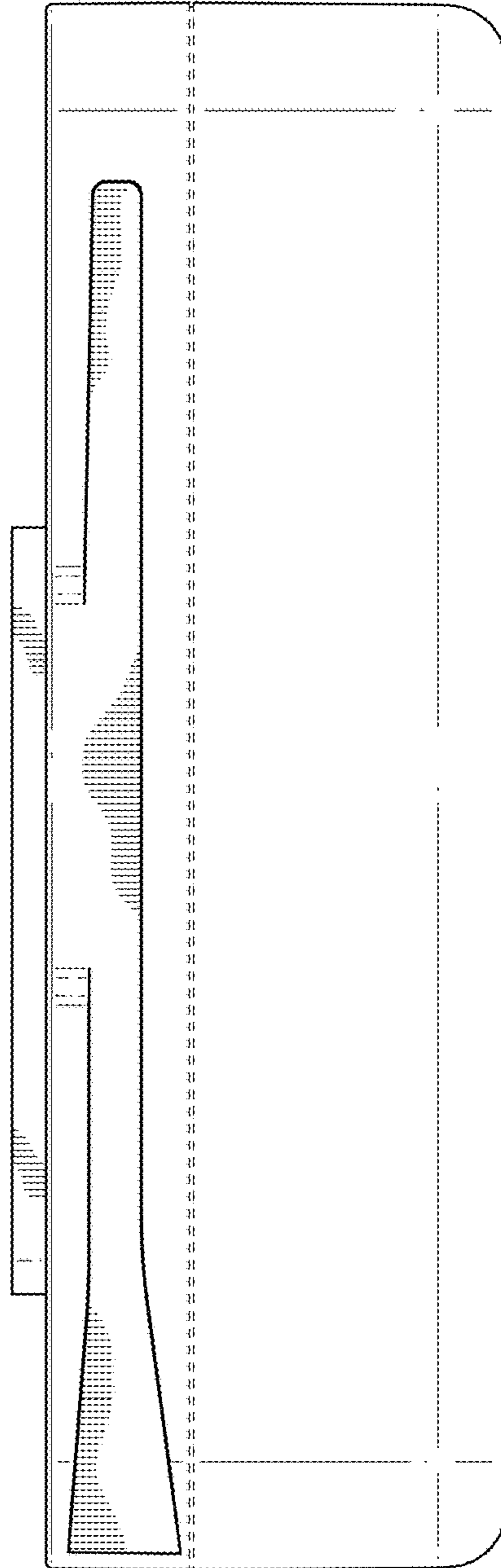

FIG. 7

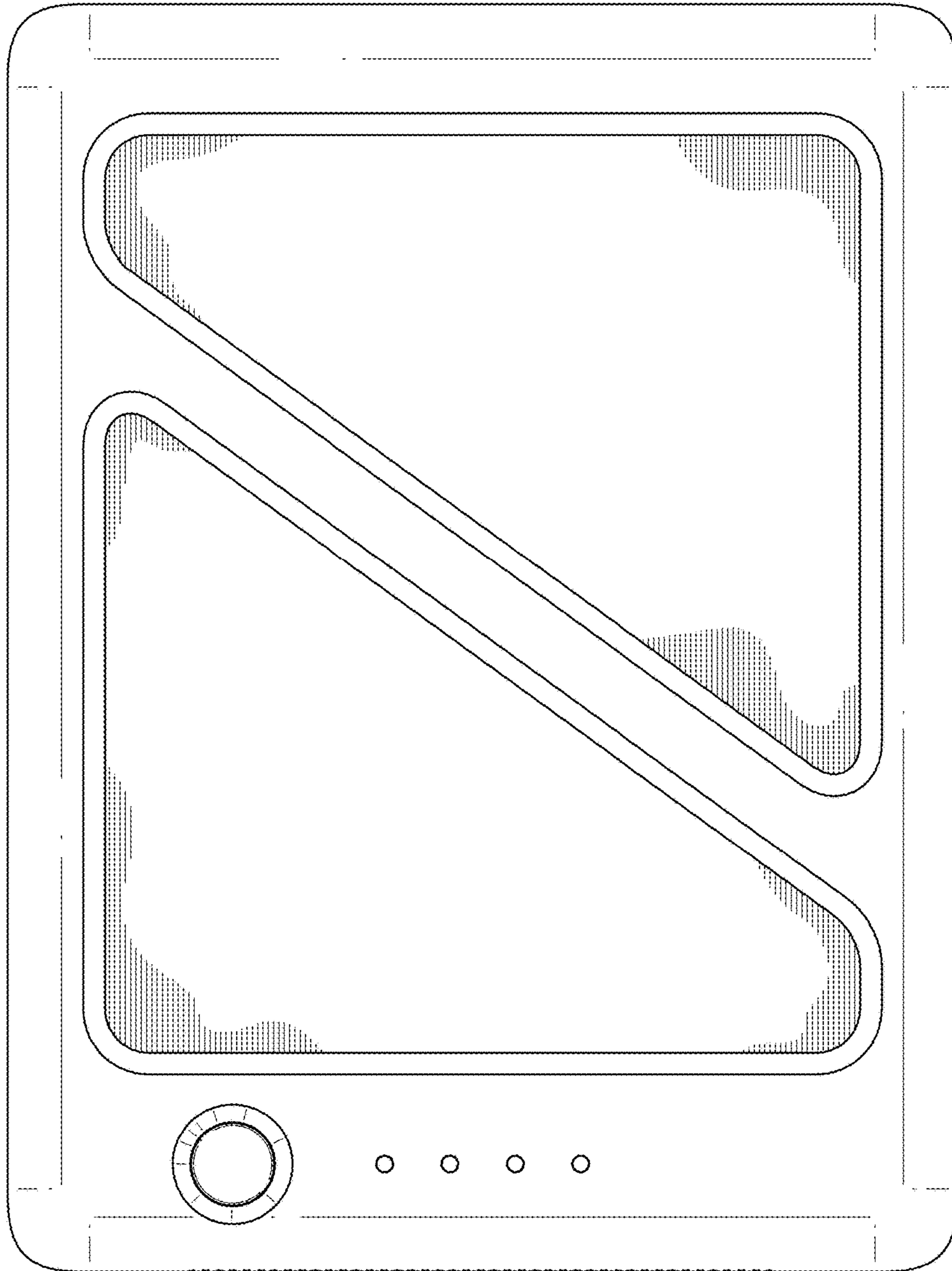

FIG. 8



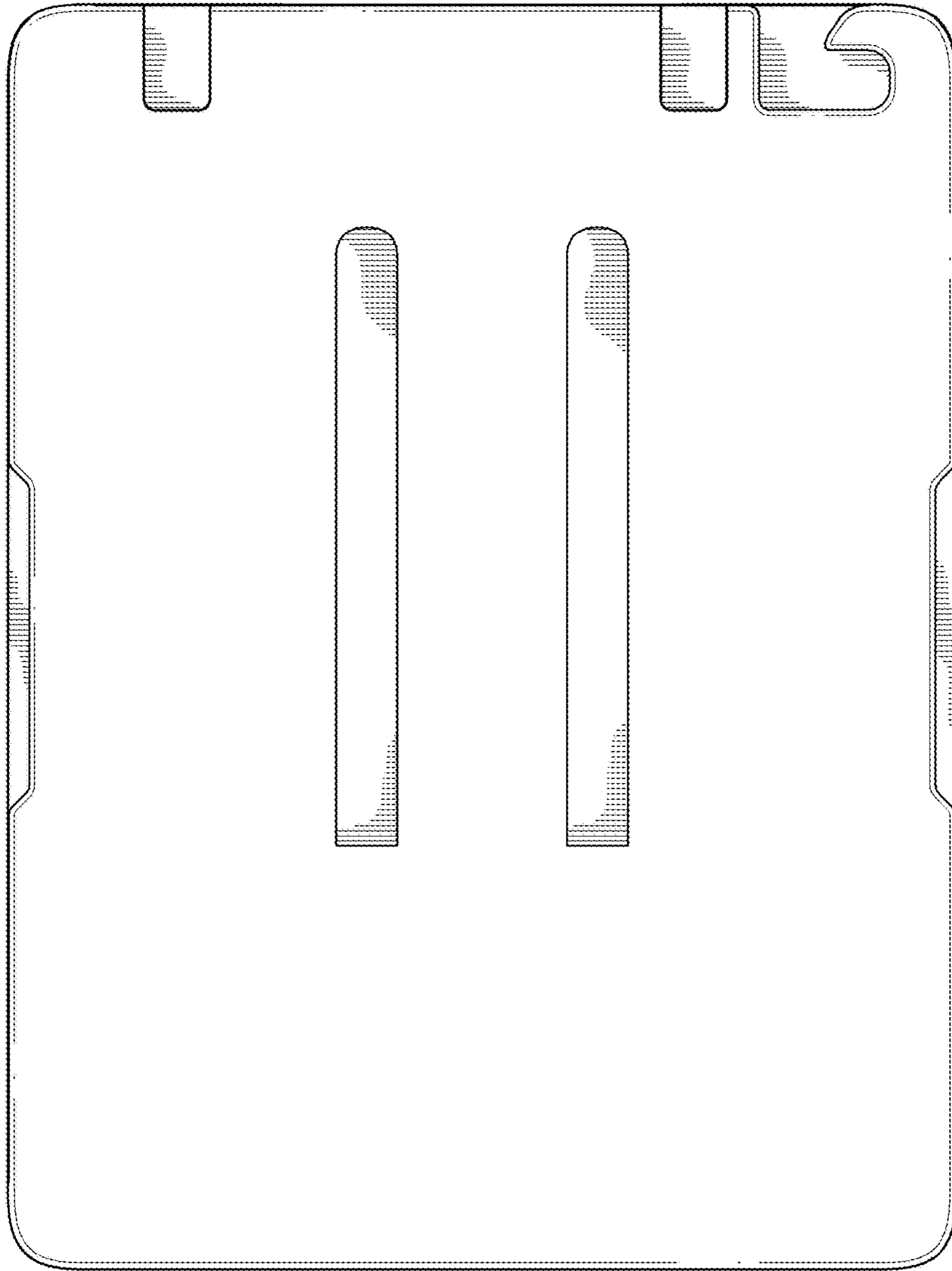

FIG. 9