



US00D819283S

(12) **United States Design Patent** (10) **Patent No.:** **US D819,283 S**
Hitchens (45) **Date of Patent:** **** *May 29, 2018**

(54) **DISPLACEABLE MANIFOLD FOR A CHEMICAL JUG WASHER**
(71) Applicant: **Paul Thomas Hitchens**, Hessel, MI (US)
(72) Inventor: **Paul Thomas Hitchens**, Hessel, MI (US)
(*) Notice: This patent is subject to a terminal disclaimer.

D744,707 S * 12/2015 Becker D32/25
D760,455 S * 6/2016 Shinozaki D32/25
D771,334 S * 11/2016 Cockman D32/25
2001/0010102 A1 * 8/2001 Spotti B08B 9/36
15/60
2004/0003832 A1 * 1/2004 Jerg A47L 15/4246
134/93
2005/0016569 A1 * 1/2005 Rosenbauer A47L 15/4246
134/105
2005/0145270 A1 7/2005 Ray
2008/0092934 A1 * 4/2008 Bechini B08B 9/36
134/167 R

(Continued)

(**) Term: **15 Years**

FOREIGN PATENT DOCUMENTS

(21) Appl. No.: **29/574,406**
(22) Filed: **Aug. 15, 2016**
(51) **LOC (11) Cl.** **15-05**
(52) **U.S. Cl.**
USPC **D32/25**
(58) **Field of Classification Search**
USPC D32/3, 25, 26, 58, 75
CPC B08B 9/28; B08B 9/0821; B08B 9/36;
B08B 9/30; A47L 15/4246
See application file for complete search history.

GB 1350361 A 4/1974
WO WO-2012/031955 A2 3/2012
WO WO-2015/075902 A1 5/2015

Primary Examiner — Michael A. Pratt
Assistant Examiner — Michelle E Wilson
(74) *Attorney, Agent, or Firm* — Dinsmore & Shohl LLP

(57) **CLAIM**

The ornamental design for a displaceable manifold for a chemical jug washer, as shown and described.

(56) **References Cited**

DESCRIPTION

U.S. PATENT DOCUMENTS

3,907,011 A * 9/1975 Edmunds B08B 9/28
134/166 R
3,916,924 A 11/1975 McGowan
4,039,351 A 8/1977 Butler
5,027,840 A 7/1991 Nezworski
5,542,440 A 8/1996 Weimer et al.
5,605,094 A * 2/1997 Besnier B08B 9/0821
100/102
5,702,536 A 12/1997 Carruth
7,726,593 B2 6/2010 Heidel
7,753,009 B2 7/2010 Quddus et al.
D655,060 S * 2/2012 Hermle D32/25
D657,509 S * 4/2012 Gabrielsson D32/25
D734,904 S * 7/2015 Dietvorst D32/25

FIG. 1 is an environmental plan view of the present design; FIG. 2 is a perspective of the present design; FIG. 3 is a front view of the present design and which is identical to a corresponding rear view; FIG. 4 is right side view of the present design and which is identical to a corresponding left side view; FIG. 5 is a top view of the present design; and, FIG. 6 is a bottom view of the present design. The broken line shown in the drawings are included for the purpose of illustrating environment and forms no part of the claimed design.

1 Claim, 4 Drawing Sheets

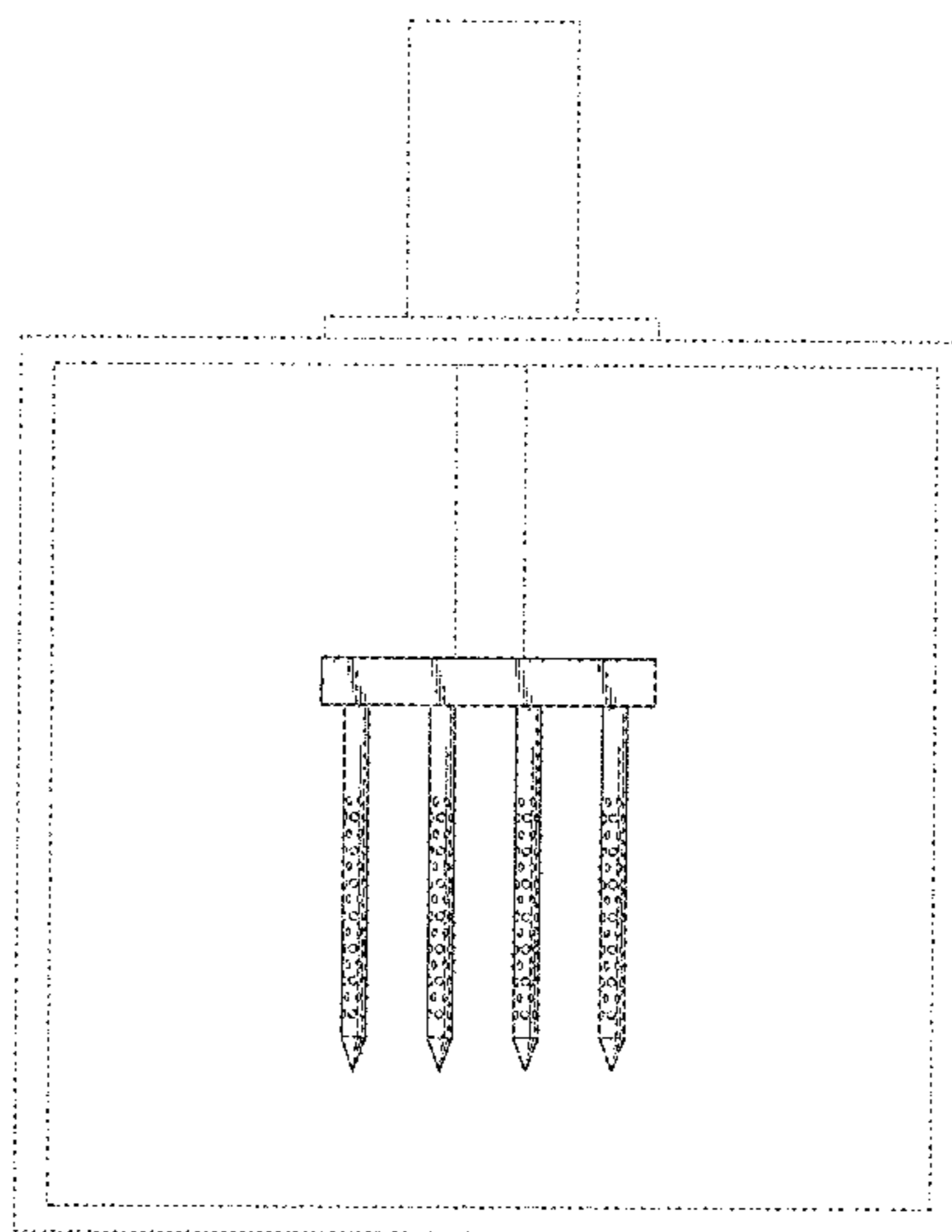

(56)

References Cited

U.S. PATENT DOCUMENTS

2010/0132740 A1 6/2010 Lehmann et al.
2015/0101286 A1 4/2015 Clarkson
2015/0239016 A1 8/2015 Spencer et al.
2016/0303624 A1 10/2016 Hitchens

* cited by examiner

FIG. 1

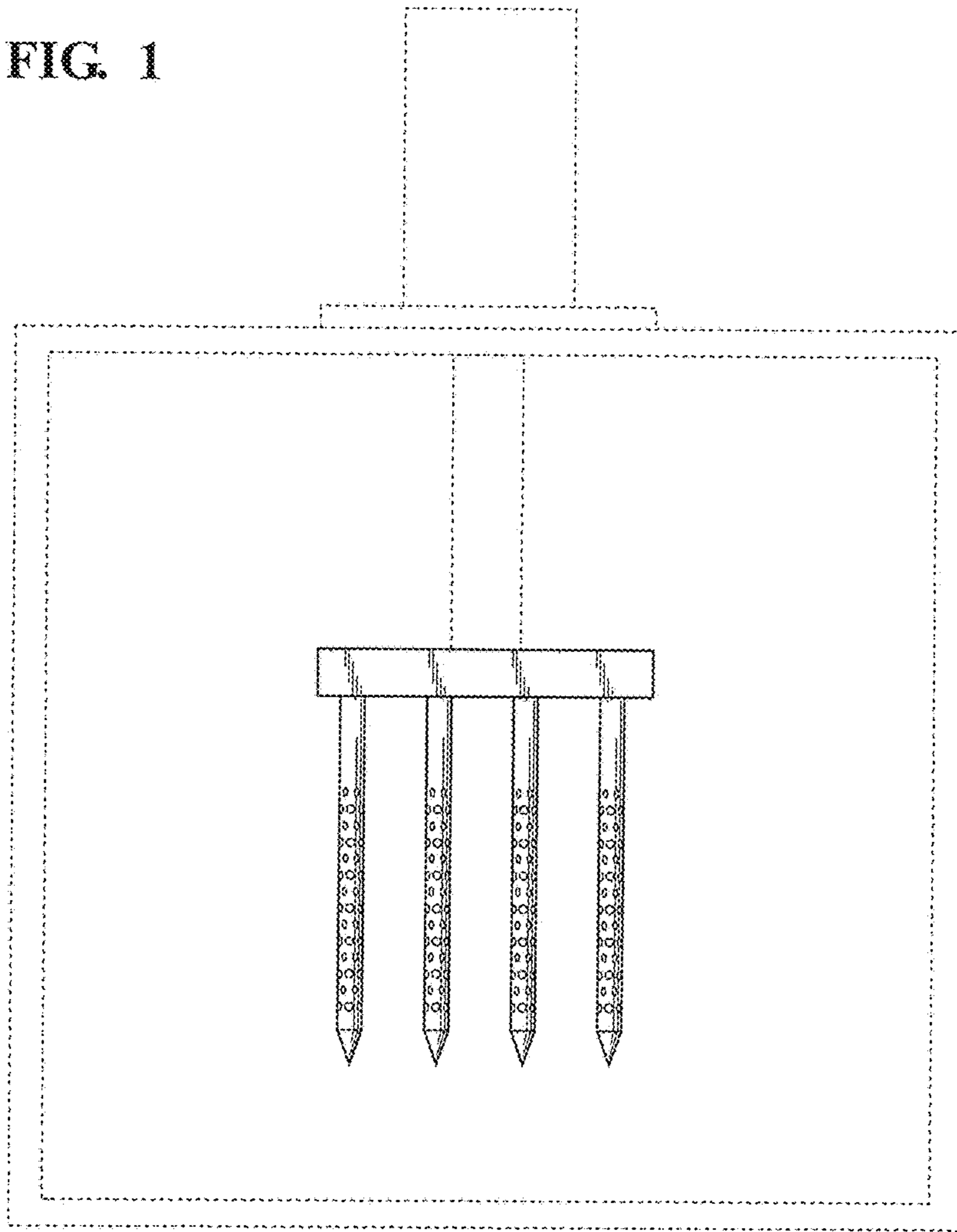

FIG. 2

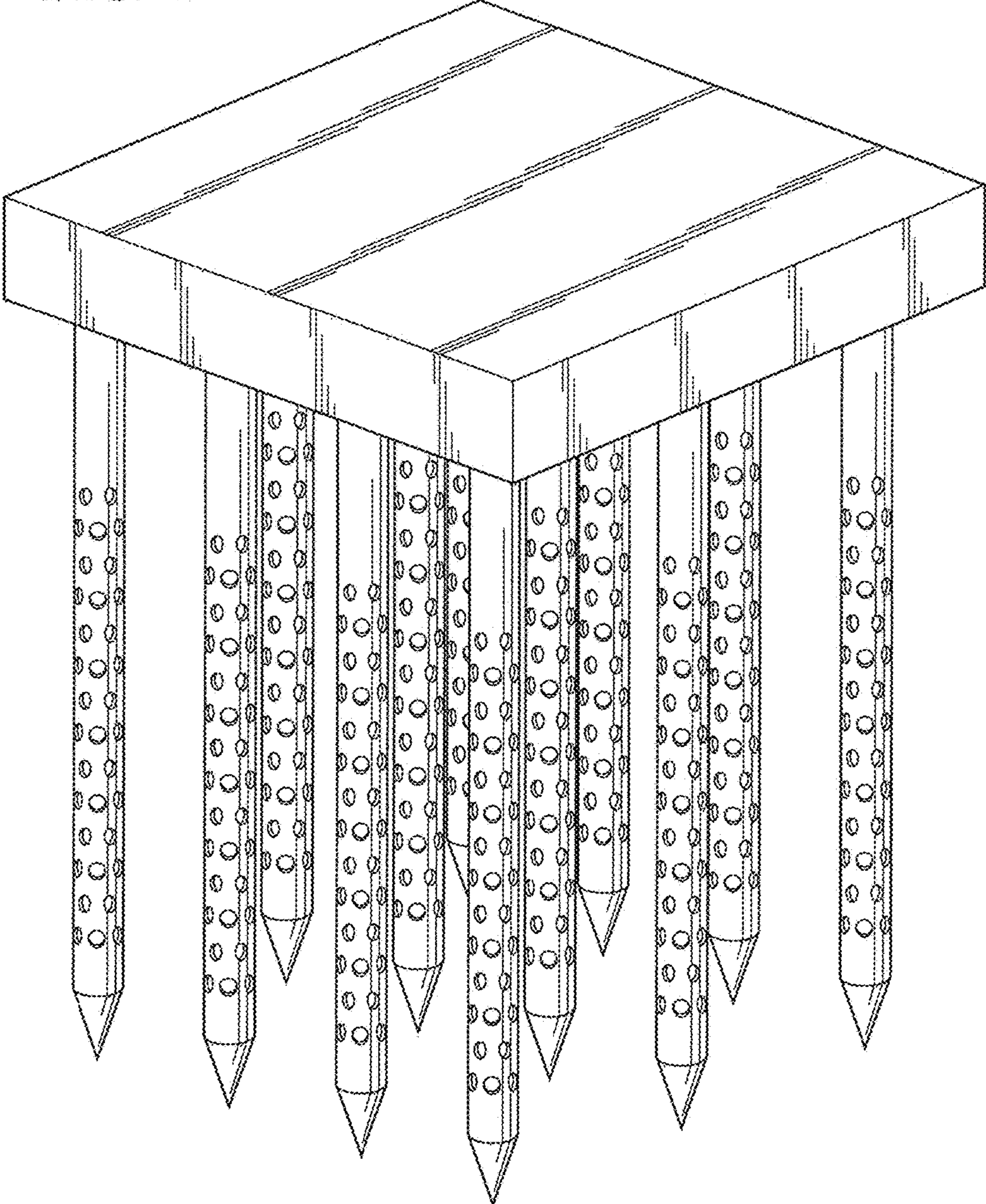

FIG. 3

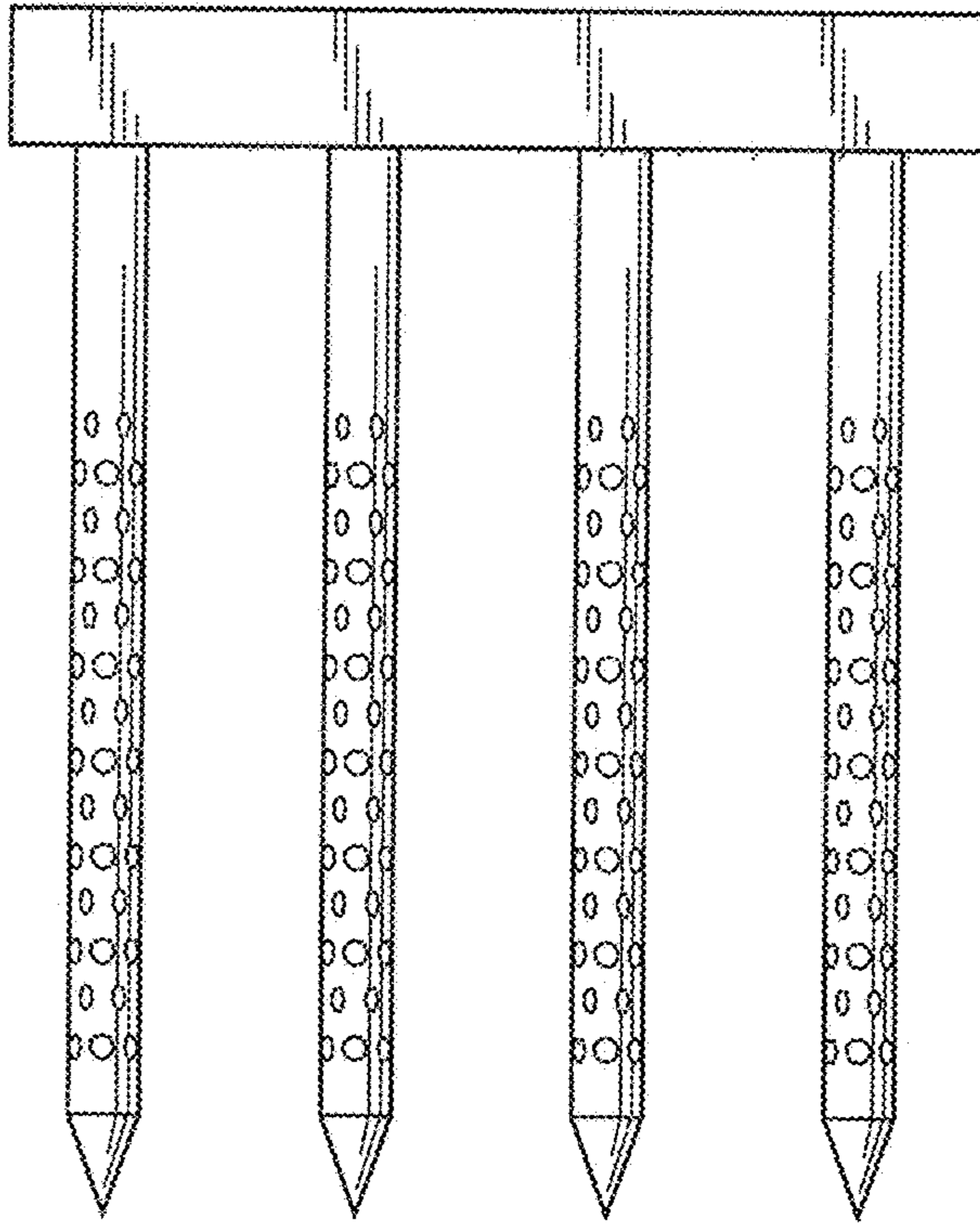

FIG. 4

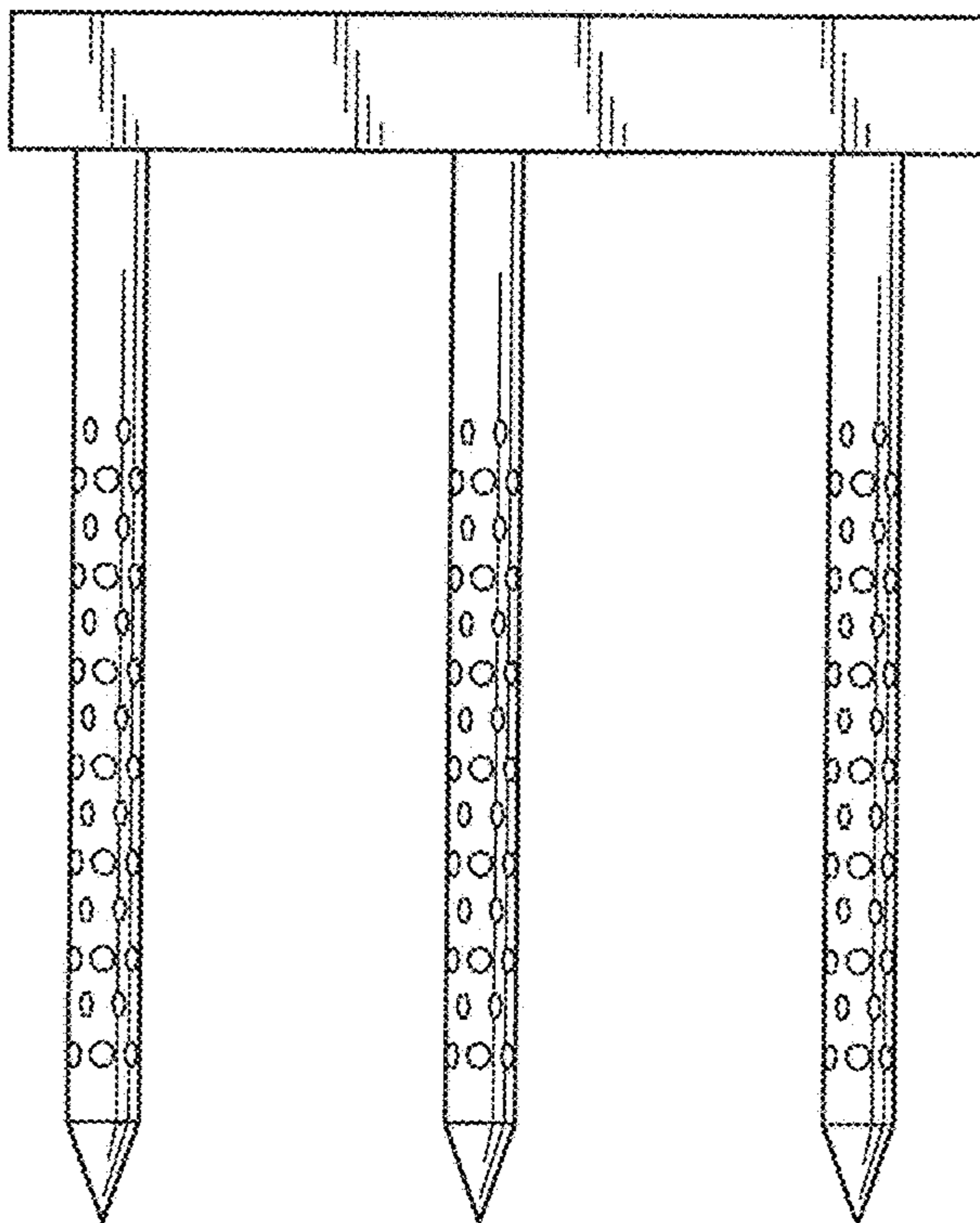

FIG. 5

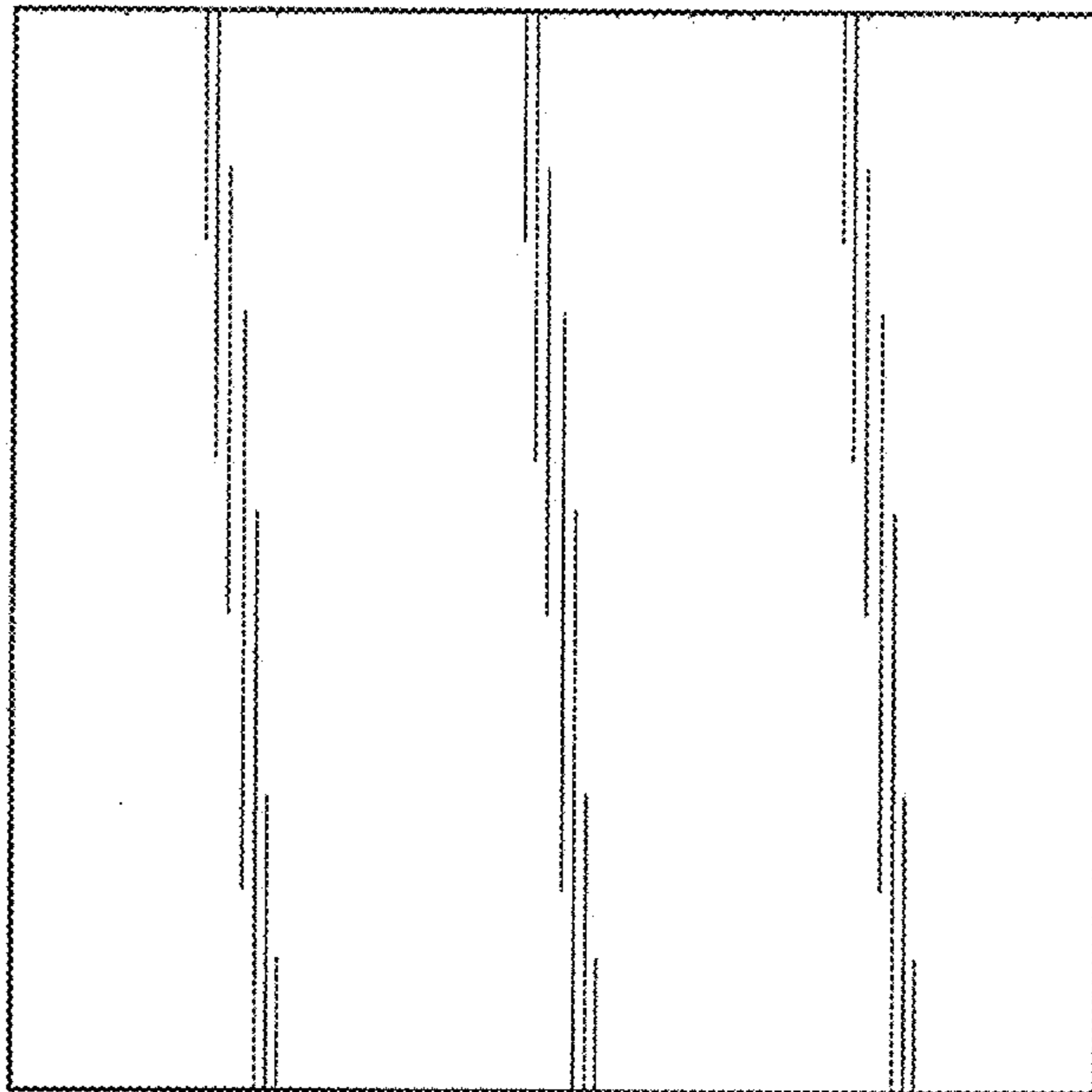

FIG. 6

