



US00D819155S

(12) **United States Design Patent** (10) **Patent No.:** **US D819,155 S**
Hunter (45) **Date of Patent:** **** May 29, 2018**

(54) **WATER RIDE** 5,527,646 A 6/1996 Ogino et al.
D375,775 S * 11/1996 King D21/818
(71) Applicant: **PROSLIDE TECHNOLOGY INC.,** D375,776 S * 11/1996 King D21/818
Ottawa, Ontario (CA) 5,716,282 A 2/1998 Ring
5,738,590 A 4/1998 Lochtefeld
(72) Inventor: **Richard D. Hunter,** Ottawa (CA) 6,006,672 A 12/1999 Newfarmer et al.
6,354,955 B1 * 3/2002 Stuart A63G 21/18
104/70
(73) Assignee: **Proslide Technology Inc.,** Ottawa (CA) 6,435,927 B1 8/2002 Fireman
6,527,646 B1 3/2003 Briggs
6,561,914 B2 5/2003 Henry
(**) Term: **15 Years** 6,702,687 B1 3/2004 Henry
6,743,108 B2 6/2004 Hunter
(21) Appl. No.: **29/571,273** 6,758,231 B1 7/2004 Lochtefeld et al.
D495,022 S * 8/2004 Auberger D21/818
(22) Filed: **Jul. 15, 2016** (Continued)

Related U.S. Application Data

(63) Continuation of application No. PCT/CA2015/050159, filed on Mar. 3, 2015.
(51) **LOC (11) Cl.** **21-03**
(52) **U.S. Cl.**
USPC **D21/821**
(58) **Field of Classification Search**
USPC D21/818-822
CPC A63G 21/00-21/22
See application file for complete search history.

FOREIGN PATENT DOCUMENTS

CA 2654714 A1 3/2002
CA 2674329 A1 1/2011
(Continued)

Primary Examiner — Mitchell I. Siegel
(74) *Attorney, Agent, or Firm* — Finnegan, Henderson, Farabow, Garrett & Dunner, L.L.P.

(57) **CLAIM**

The ornamental design of a water ride, as shown and described.

(56) **References Cited**

U.S. PATENT DOCUMENTS

2,604,055 A 7/1949 Snowden
3,000,022 A 9/1961 Cathey et al.
3,438,074 A 4/1969 Goyen
4,394,173 A * 7/1983 Aste A63C 19/10
104/124
D308,563 S * 6/1990 Knight D21/819
5,031,556 A 7/1991 Blee
5,213,547 A 5/1993 Lochtefeld
5,219,315 A 6/1993 Fuller et al.
5,230,662 A * 7/1993 Langford A63G 21/18
472/117
5,503,597 A 4/1996 Lochtefeld

DESCRIPTION

FIG. 1 is a perspective view of a water ride showing my new design;
FIG. 2 is a front view thereof;
FIG. 3 is a rear view thereof;
FIG. 4 is a left side view thereof;
FIG. 5 is a right side view thereof;
FIG. 6 is a top view thereof; and,
FIG. 7 is a bottom view thereof.

1 Claim, 7 Drawing Sheets

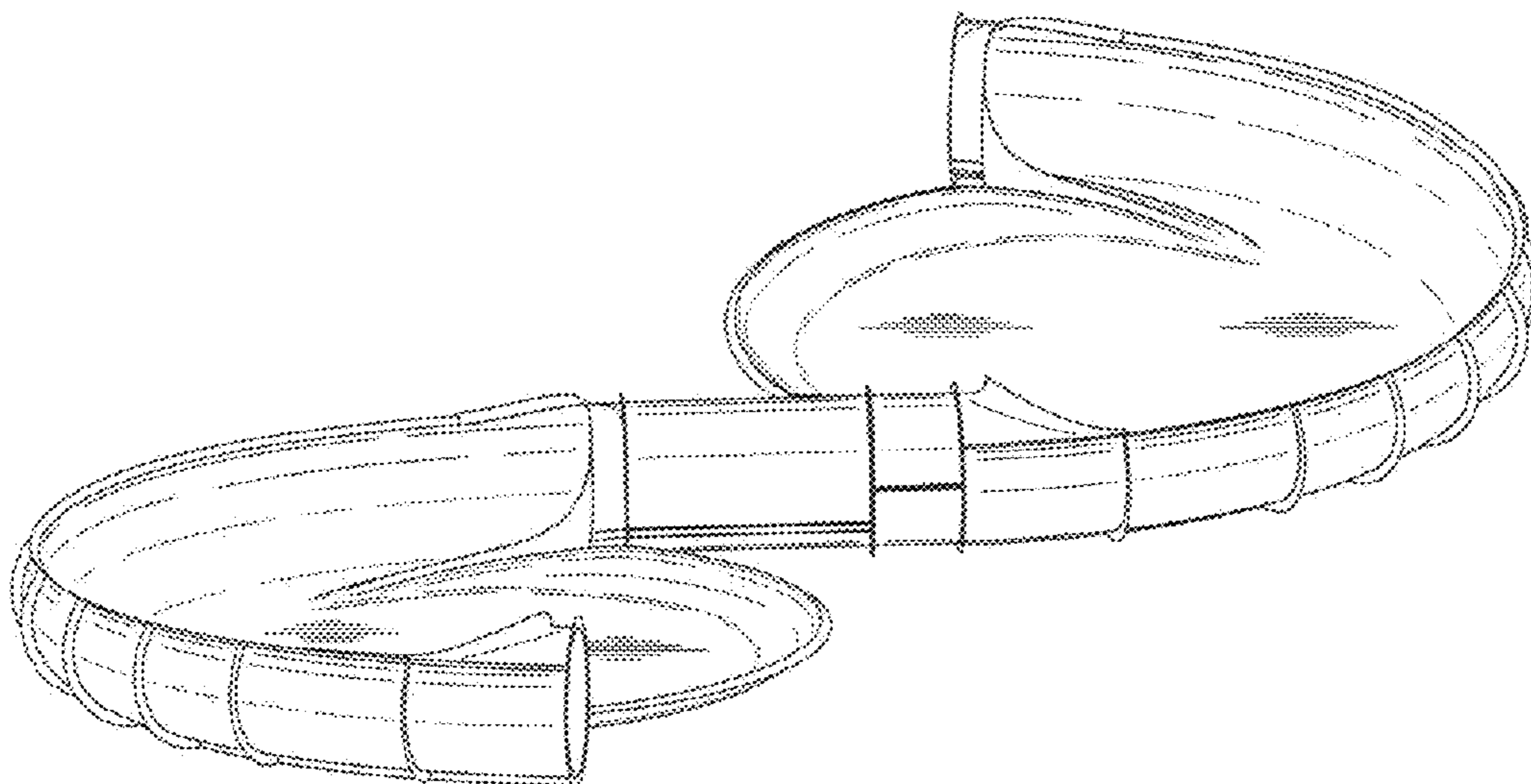

(56)

References Cited

U.S. PATENT DOCUMENTS

D521,098 S * 5/2006 Hunter A63G 31/007
 D21/819
 7,229,359 B2 6/2007 Henry
 D548,810 S * 8/2007 Hunter D21/821
 7,285,053 B2 10/2007 Henry et al.
 D567,322 S * 4/2008 Hunter D21/821
 D583,895 S * 12/2008 Hlynka D21/821
 7,497,784 B2 3/2009 Henry
 7,727,077 B2 6/2010 Henry et al.
 7,731,595 B2 6/2010 Hlynka
 7,740,542 B2 6/2010 Henry et al.
 7,758,435 B2 7/2010 Henry et al.
 7,758,535 B2 7/2010 Levine et al.
 7,762,900 B2 7/2010 Henry et al.
 7,766,753 B2 8/2010 Henry et al.
 7,780,537 B2 * 8/2010 Hlynka A63G 21/18
 472/117
 7,785,207 B2 8/2010 Henry et al.
 D629,861 S * 12/2010 Cuttell D21/821
 7,887,426 B2 * 2/2011 Hlynka A63G 21/18
 104/70
 7,942,752 B2 5/2011 Henry
 7,967,692 B2 6/2011 Werner
 D650,463 S * 12/2011 Degirmenci D21/819
 8,070,616 B2 12/2011 Dubois et al.
 8,075,413 B2 12/2011 Henry et al.
 8,079,916 B2 12/2011 Henry
 8,192,291 B2 * 6/2012 Brassard A63G 21/10
 104/69
 8,197,353 B2 * 6/2012 Brassard A63G 21/18
 104/69
 8,210,954 B2 7/2012 Henry et al.
 8,282,497 B2 10/2012 Henry et al.

8,360,894 B2 * 1/2013 Hlynka A63G 21/18
 472/117
 8,360,895 B2 1/2013 Brown
 8,430,760 B2 * 4/2013 Brassard A63G 21/18
 472/117
 8,453,579 B2 6/2013 Nemeth
 8,579,715 B2 * 11/2013 Olive A63G 21/18
 472/116
 D699,805 S * 2/2014 Green D21/818
 D705,381 S * 5/2014 Brassard D21/821
 D758,517 S * 6/2016 Gonzalez D21/818
 D771,213 S * 11/2016 Ozturk D21/821
 D779,010 S * 2/2017 Ozturk D21/821
 2010/0160054 A1 6/2010 Henry
 2012/0201605 A1 8/2012 Hill
 2012/0258812 A1 10/2012 Osterman et al.
 2013/0184087 A1 7/2013 Degirmenci
 2016/0136527 A1 5/2016 Hunter
 2017/0043264 A1 2/2017 Hunter et al.
 2017/0106295 A1 4/2017 Hunter

FOREIGN PATENT DOCUMENTS

CA 2778601 A1 5/2011
 CA 2690687 A1 6/2011
 CN 2905159 5/2007
 CN 101417179 A 4/2009
 JP H-03258280 11/1991
 WO WO 88/05745 A1 8/1988
 WO WO 2012/048016 A2 4/2012
 WO WO 2013/000090 A1 1/2013
 WO WO 2014/059551 A1 4/2014
 WO WO 2015/161382 A1 10/2015
 WO WO 2015/188265 A1 12/2015

* cited by examiner

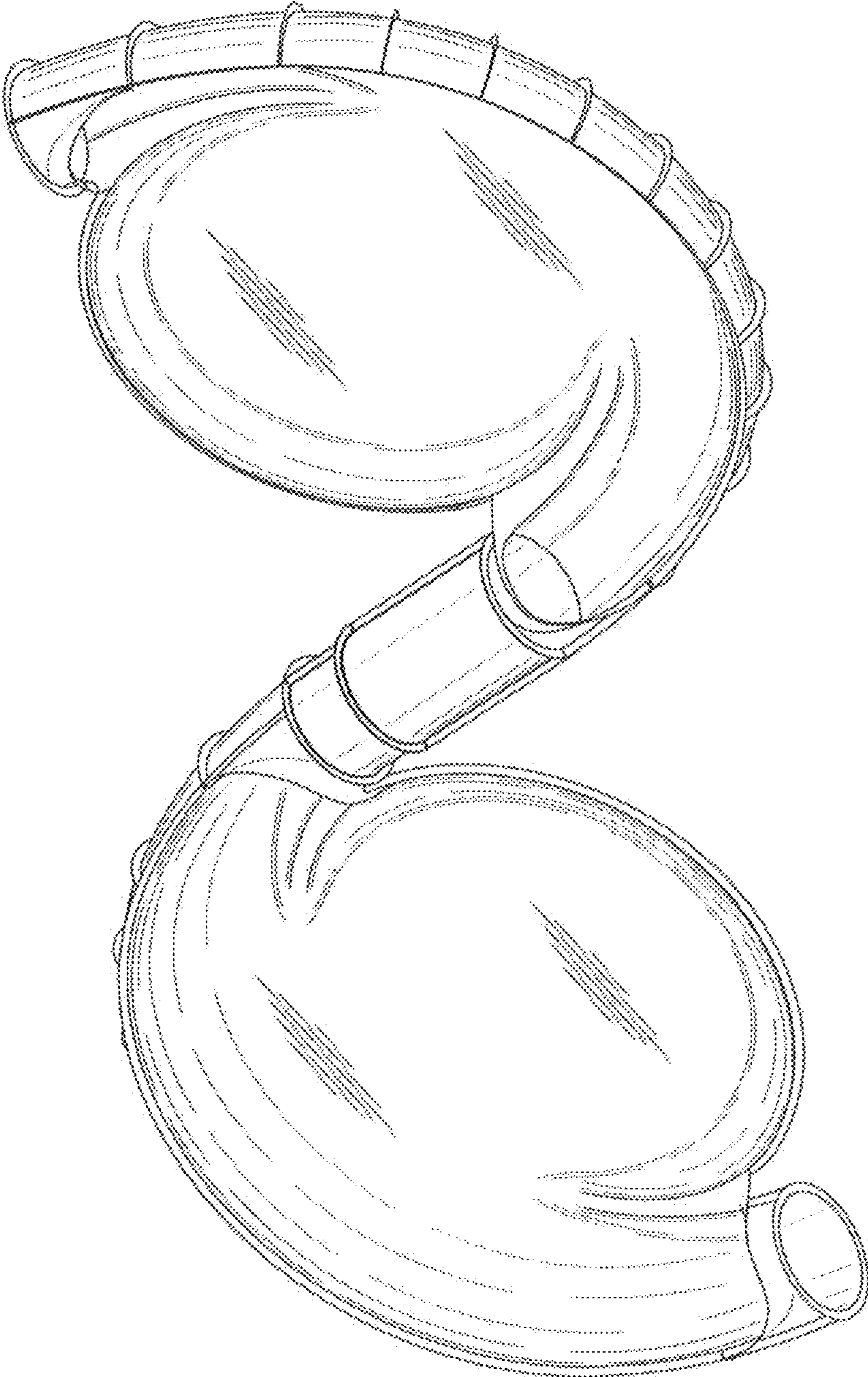

FIG. 1

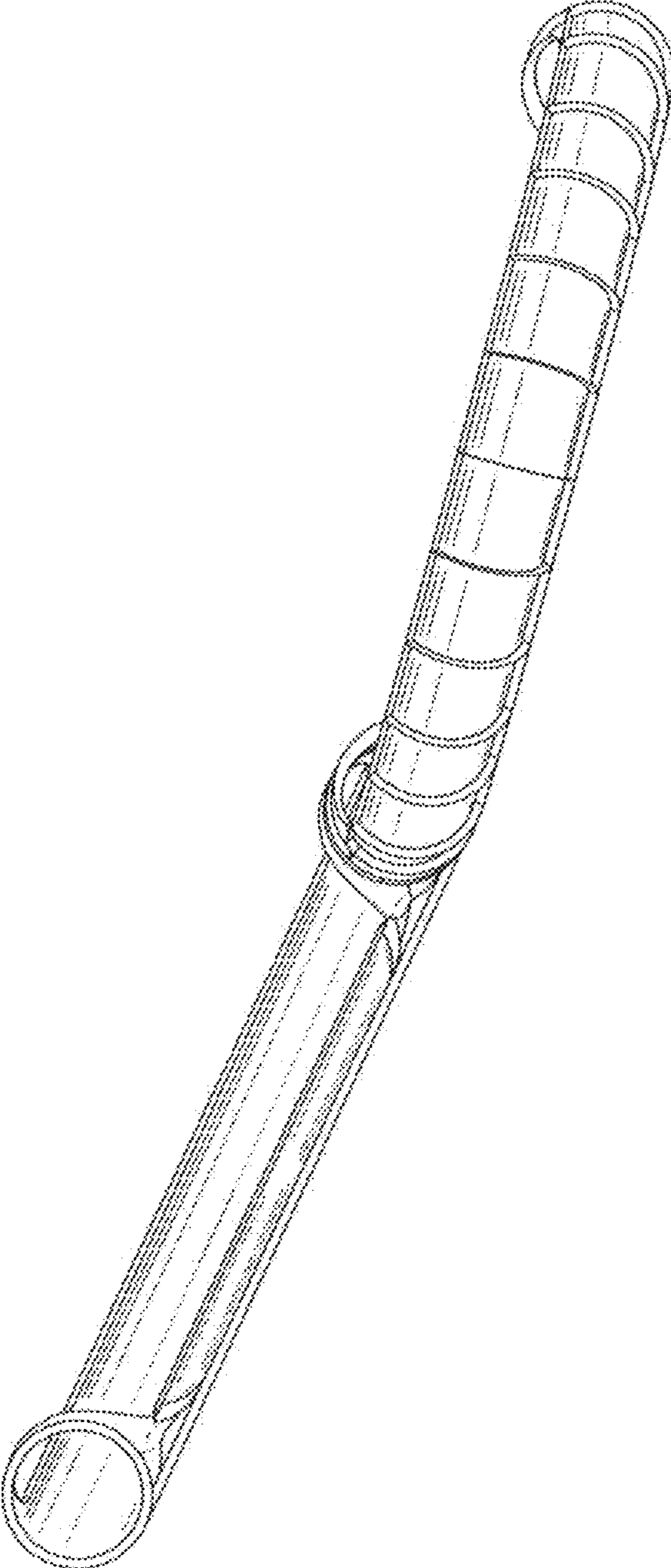

FIG. 2

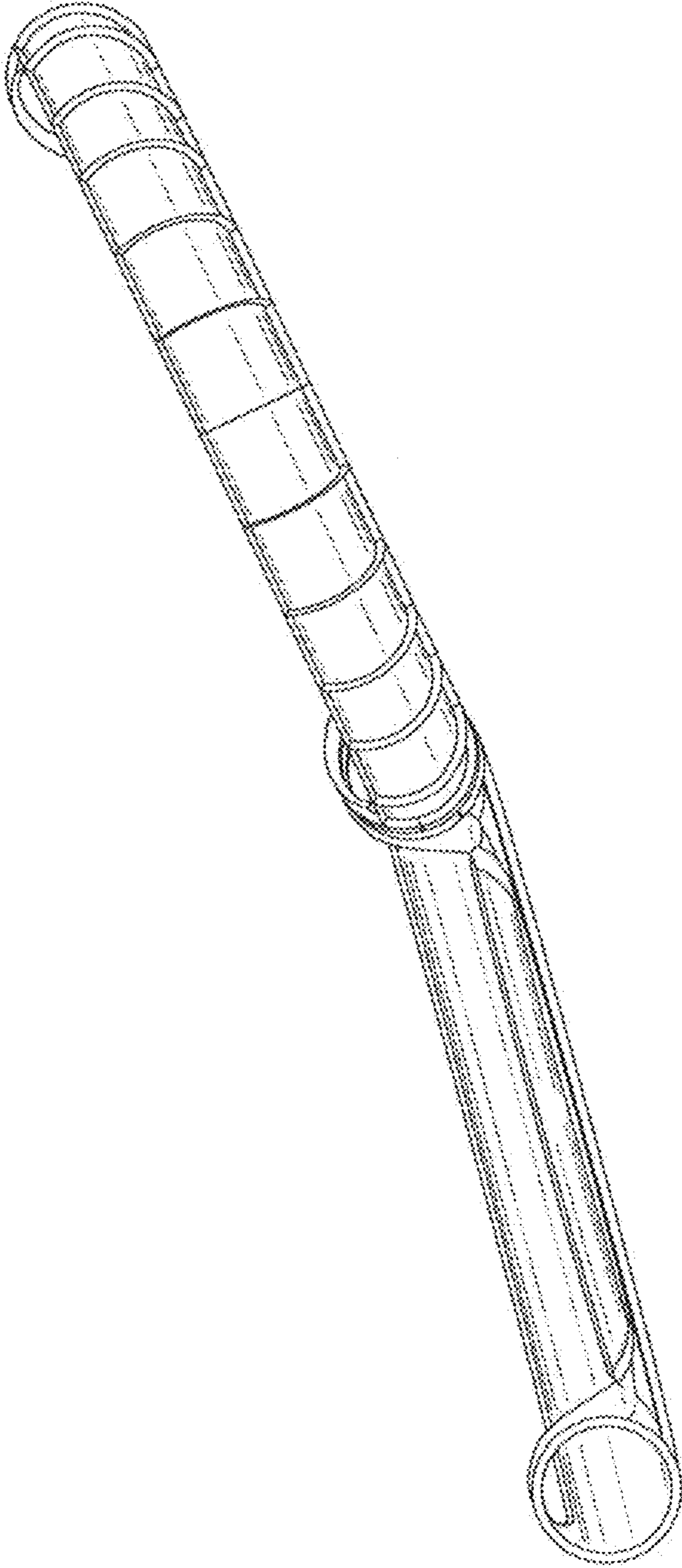

FIG. 3

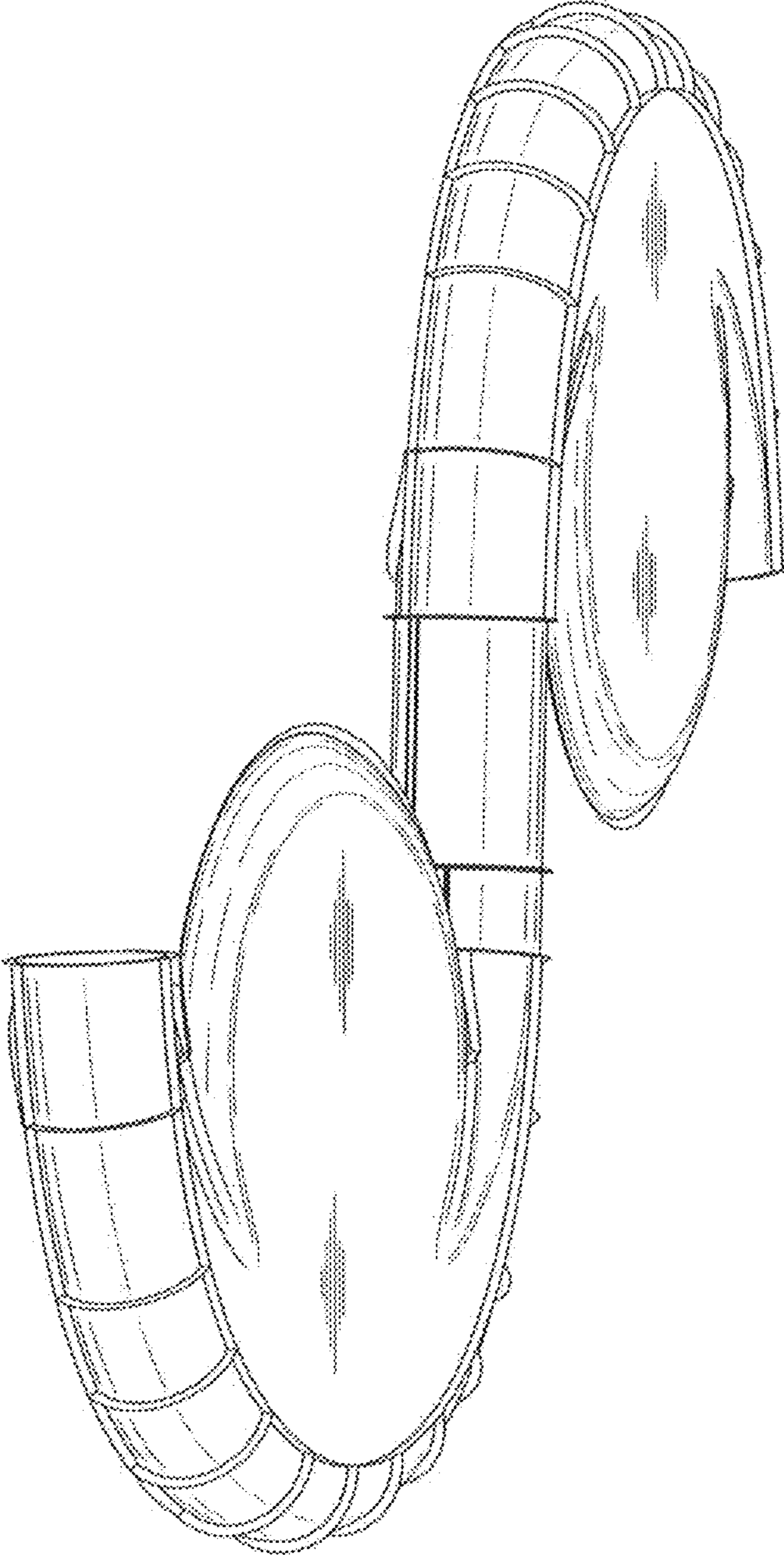

FIG. 4

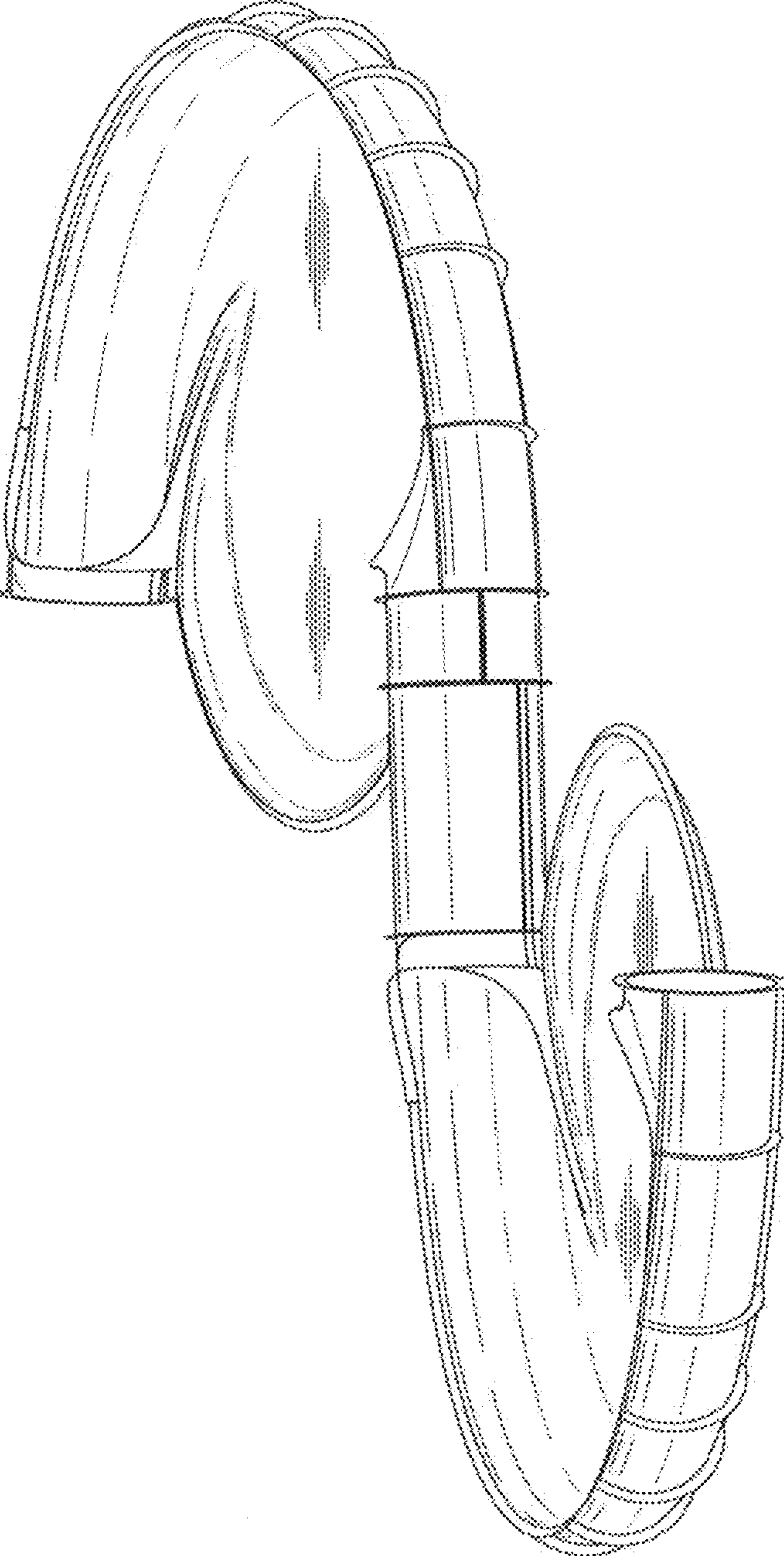

FIG. 5

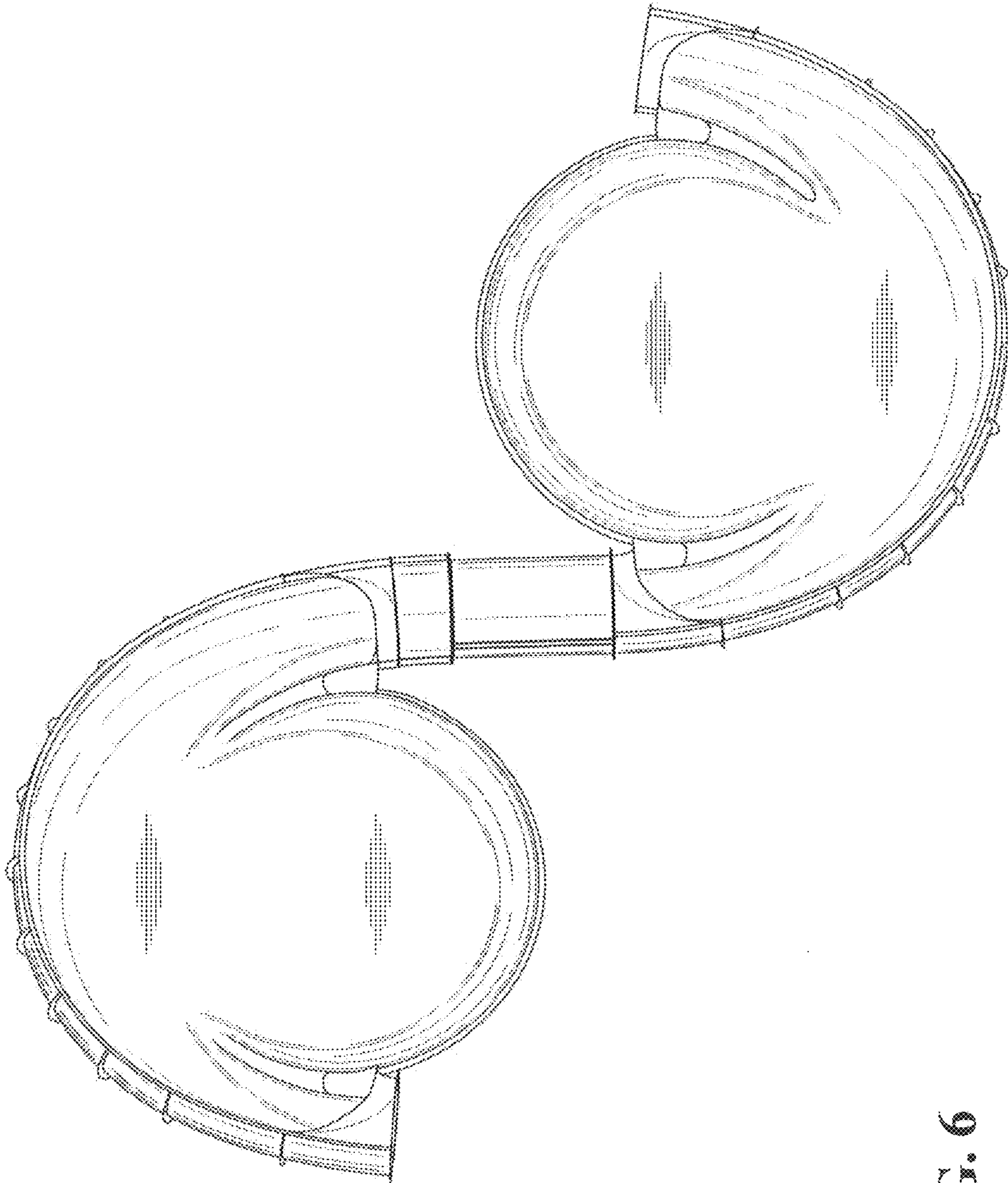

FIG. 6

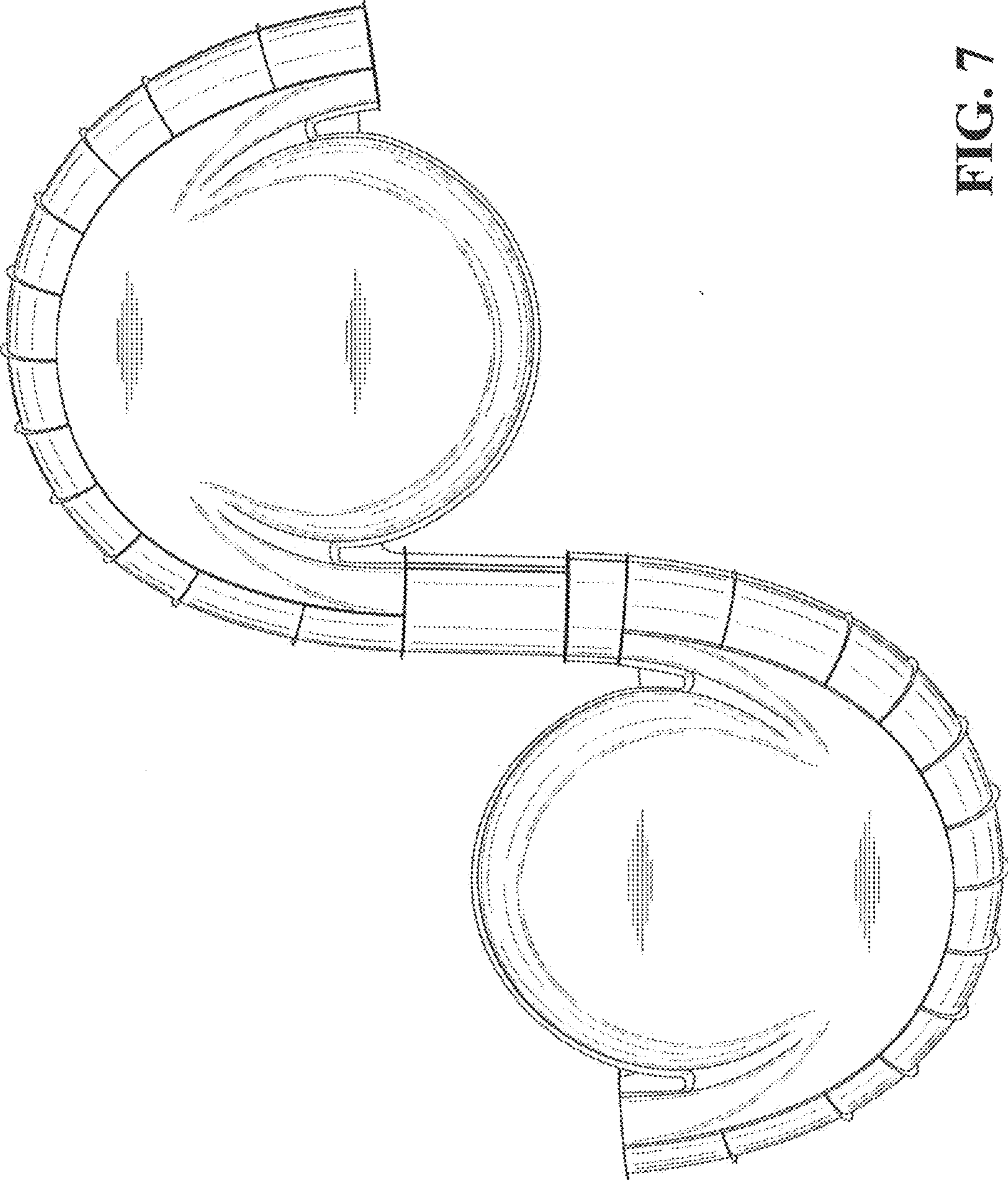

FIG. 7