



US00D818898S

(12) **United States Design Patent**
Anderson et al.

(10) **Patent No.:** **US D818,898 S**

(45) **Date of Patent:** **** May 29, 2018**

- (54) **BUMPER FOR VEHICLE**
- (71) Applicant: **Volvo Lastvagnar AB**, Göteborg (SE)
- (72) Inventors: **Ian Anderson**, Greensboro, NC (US);
Jeff Cotner, Greensboro, NC (US)
- (73) Assignee: **VOLVO LASTVAGNAR AB**,
Gothenburg (SE)
- (**) Term: **15 Years**
- (21) Appl. No.: **29/600,044**
- (22) Filed: **Apr. 10, 2017**
- (51) **LOC (11) Cl.** **12-16**
- (52) **U.S. Cl.**
USPC **D12/169**
- (58) **Field of Classification Search**
USPC D12/169, 216, 90-92, 86, 171, 196, 163;
293/102, 113, 115, 117, 120; 296/180.1,
296/180.2
CPC B60R 19/02; B60R 19/04; B62D 25/08
See application file for complete search history.

- D746,736 S * 1/2016 Wolff D12/169
- D746,737 S * 1/2016 Wolff D12/169
- D746,738 S * 1/2016 Wolff D12/169
- D774,428 S * 12/2016 Davidson D12/169
- D776,021 S * 1/2017 Kapitonov D12/169
- D778,213 S * 2/2017 Platto D12/169
- D803,737 S * 11/2017 Granlund D12/169
- D805,970 S * 12/2017 Villamizar D12/169

OTHER PUBLICATIONS

Images of Volvo VNL Truck, released 2002, 2 pages.

* cited by examiner

Primary Examiner — Melody N Brown

(74) *Attorney, Agent, or Firm* — Tucker Ellis LLP

(57) **CLAIM**

The ornamental design for a bumper for vehicle, as shown and described.

DESCRIPTION

FIG. 1 is a top, front and right side perspective view of a bumper for vehicle showing our new design;
FIG. 2 is a front elevational view thereof;
FIG. 3 is a bottom plan view thereof;
FIG. 4 is a right side elevational view thereof; and,
FIG. 5 is a left side elevational view thereof.

1 Claim, 3 Drawing Sheets

(56) **References Cited**
U.S. PATENT DOCUMENTS

- D629,728 S * 12/2010 Akasawa D12/169
- D683,670 S * 6/2013 Platto D12/169
- D699,164 S * 2/2014 Watabe D12/169
- D721,303 S * 1/2015 Platto D12/169
- D721,621 S * 1/2015 Platto D12/169

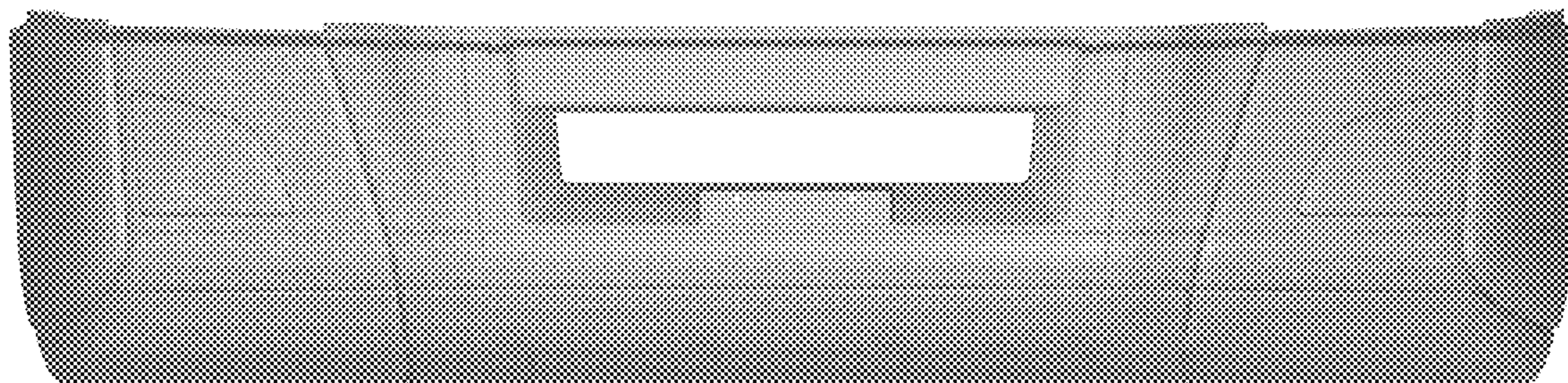

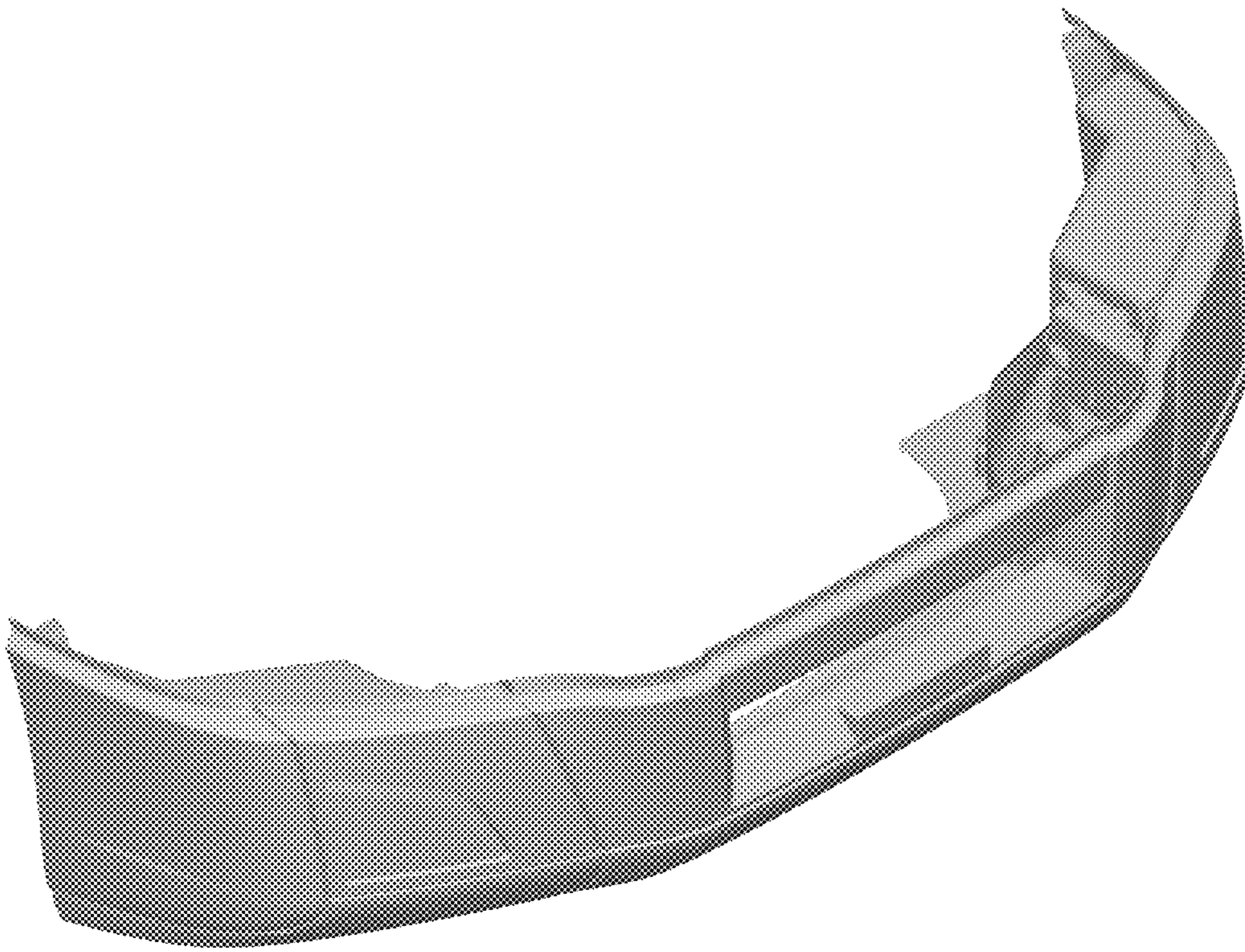

FIG. 1

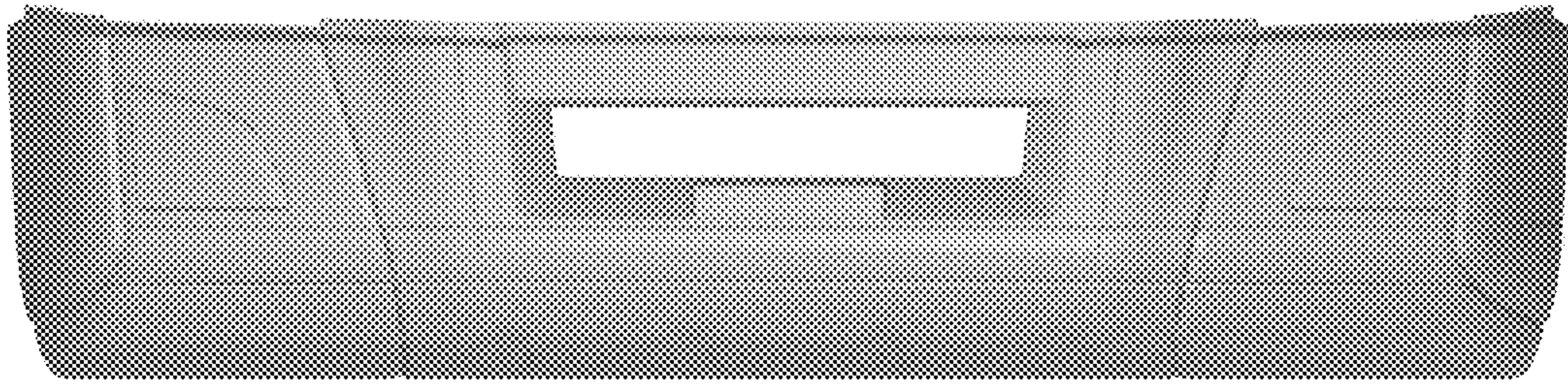

FIG. 2

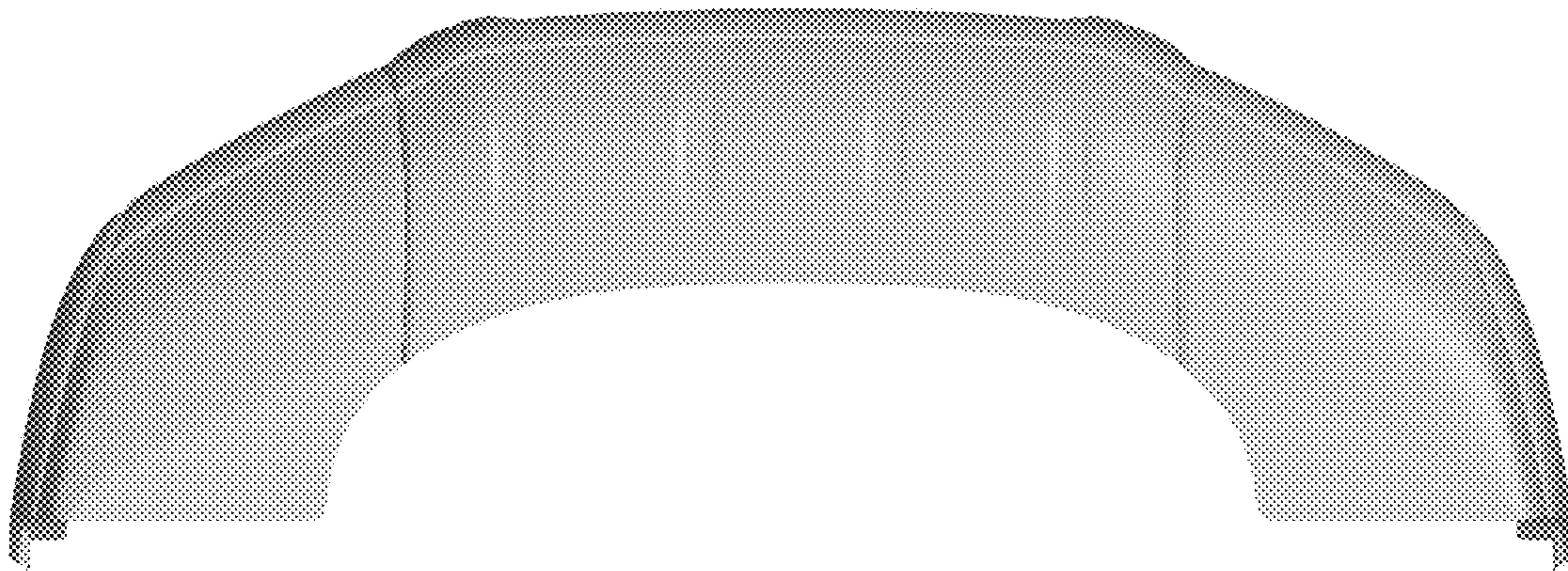

FIG. 3

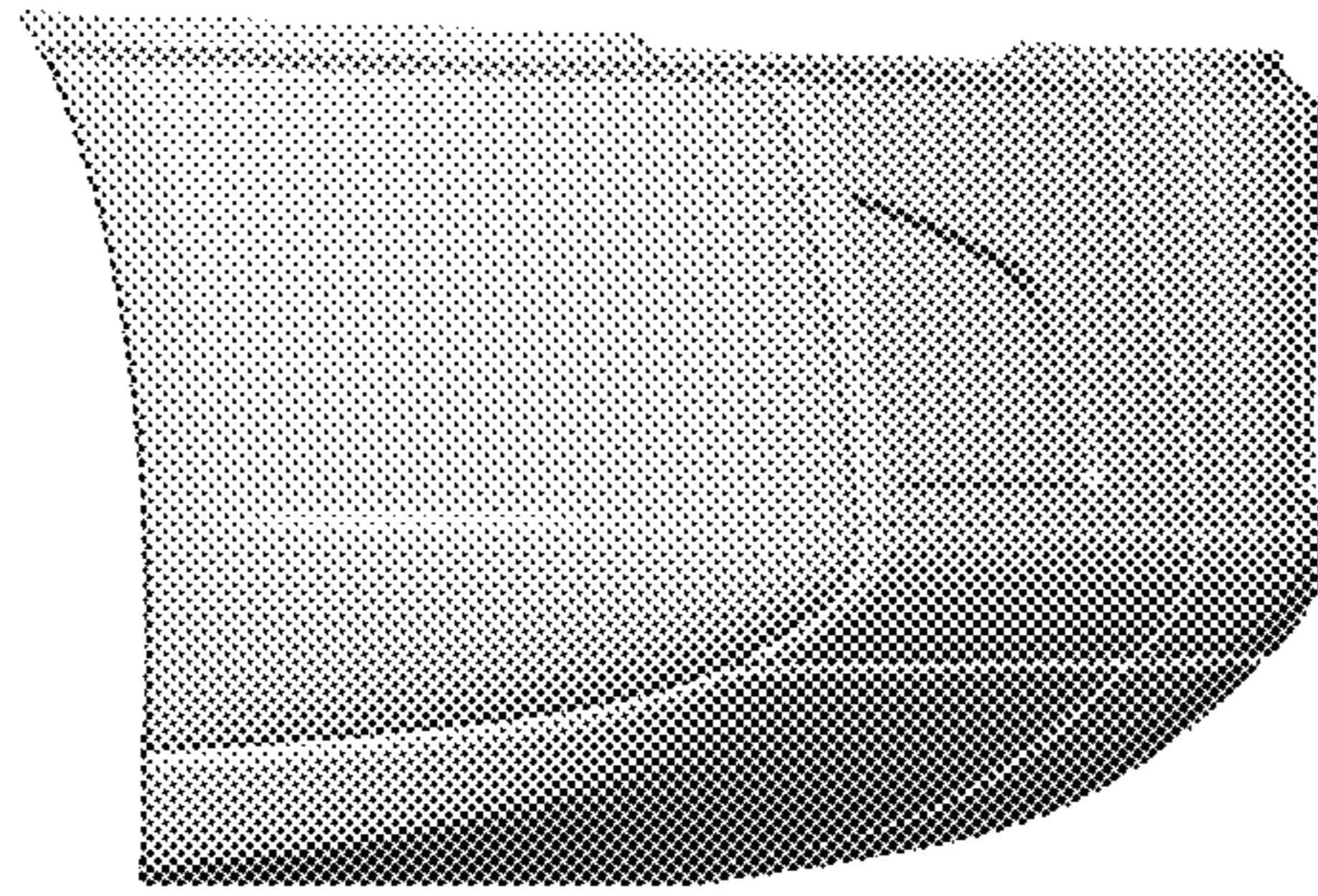

FIG. 4

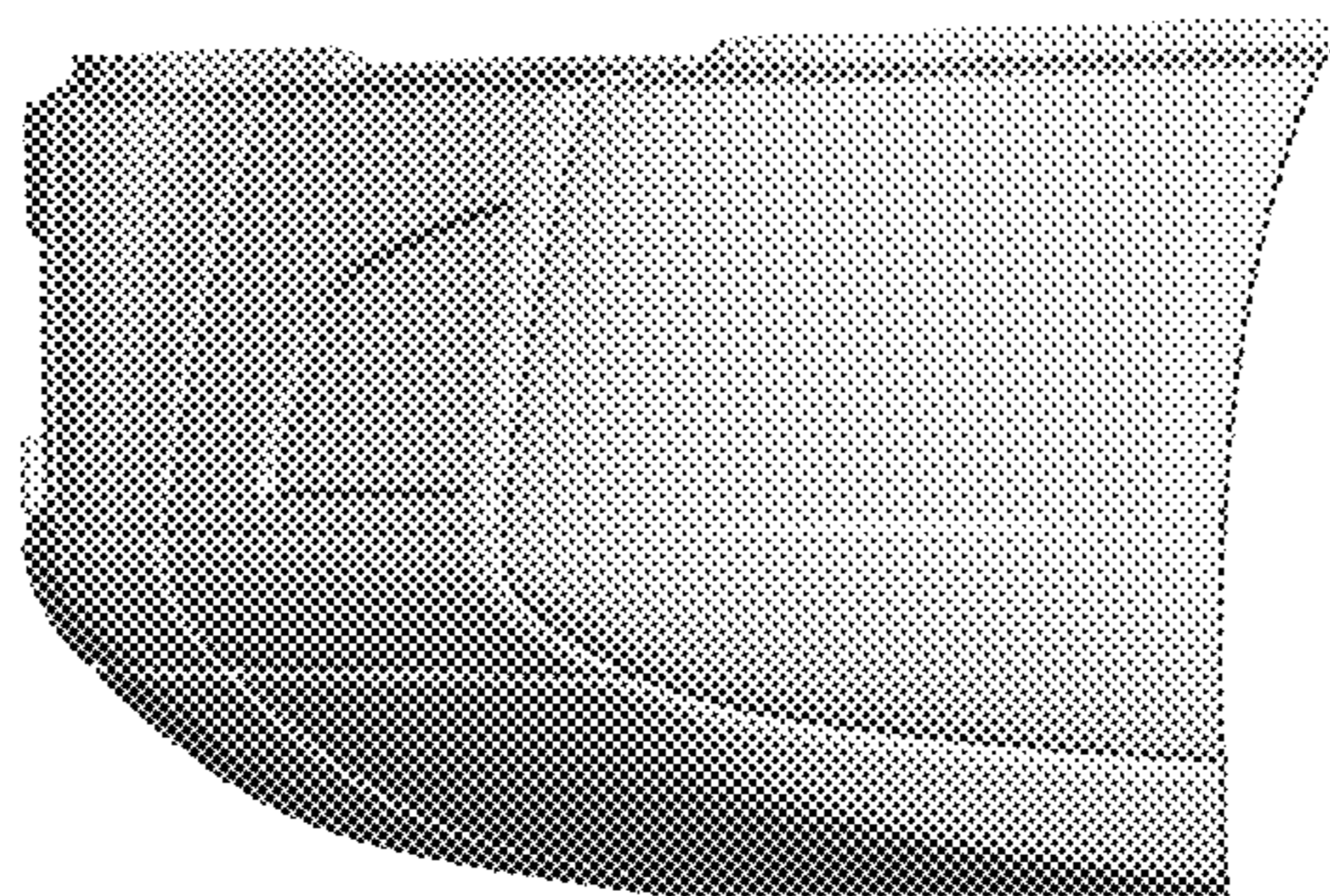

FIG. 5