



US00D818266S

(12) **United States Design Patent**  
**Hawkes**

(10) **Patent No.:** **US D818,266 S**

(45) **Date of Patent:** **\*\* May 22, 2018**

(54) **HANDBAG**

(71) Applicant: **Louis Vuitton Malletier**, Paris (FR)

(72) Inventor: **Erin Hawkes**, Paris (FR)

(73) Assignee: **LOUIS VUITTON MALLETIER**,  
Paris (FR)

(\*\*) Term: **15 Years**

(21) Appl. No.: **29/608,941**

(22) Filed: **Jun. 27, 2017**

(30) **Foreign Application Priority Data**

Dec. 28, 2016 (FR) ..... 2016-6463

(51) **LOC (11) Cl.** ..... **03-01**

(52) **U.S. Cl.**  
USPC ..... **D3/232**

(58) **Field of Classification Search**  
USPC ..... D3/232–233, 240–243, 245–246, 318  
CPC ..... A45C 1/024; A45C 3/06  
See application file for complete search history.

(56) **References Cited**

**U.S. PATENT DOCUMENTS**

D489,894 S *	5/2004	Guyon	.....	D3/246
D504,015 S *	4/2005	Delafontaine	.....	D3/233
D539,535 S *	4/2007	Guyon	.....	D3/243
D583,560 S *	12/2008	Gerbi	.....	D3/245
D595,050 S *	6/2009	Guyon	.....	D3/232
D609,909 S *	2/2010	Guyon	.....	D3/245
D615,297 S *	5/2010	Gerbi	.....	D3/245
D627,558 S *	11/2010	Gerbi	.....	D3/232
D658,369 S *	5/2012	Schiffman	.....	D3/243
D683,959 S *	6/2013	Guyon	.....	D3/245
D693,572 S *	11/2013	Kuster	.....	D3/243
D728,224 S *	5/2015	Puppa	.....	D3/243
D756,115 S *	5/2016	Slimane	.....	D3/245

D758,721 S *	6/2016	Maniez De La Hennerie	.....	D3/243
D767,887 S *	10/2016	Kim	.....	D3/245
D773,177 S *	12/2016	Abel	.....	D3/232
D783,278 S *	4/2017	Guyon	.....	D3/245
D794,327 S *	8/2017	Venturini Fendi	.....	D3/245
D799,209 S *	10/2017	Spaziani	.....	D3/245

**OTHER PUBLICATIONS**

Any (good or bad) thoughts on the Tuileries Besace and the Tuileries tote, by Sourisbrune, dated Feb. 14, 2017, forum.purseblog.com [online]. Retrieved from Internet <URL:https://forum.purseblog.com/threads/any-good-or-bad-thoughts-on-the-tuileries-besace-and-the-tuileries-tote.960662/> (Year: 2017).\*

\* cited by examiner

*Primary Examiner* — Cathron C Brooks

*Assistant Examiner* — Andrew T Nemeth

(74) *Attorney, Agent, or Firm* — Finnegan, Henderson, Farabow, Garrett & Dunner LLP

(57) **CLAIM**

The ornamental design for a handbag, as shown and described.

**DESCRIPTION**

FIG. 1 is a top, front, left perspective view of a handbag showing my new design;  
FIG. 2 is a front elevation view thereof;  
FIG. 3 is rear elevation view thereof;  
FIG. 4 is a left side view thereof;  
FIG. 5 a right side view thereof;  
FIG. 6 is a top plan view thereof; and,  
FIG. 7 is a bottom plan view thereof.  
The broken lines shown in the drawings represent stitching and form part of the claimed design.

**1 Claim, 7 Drawing Sheets**

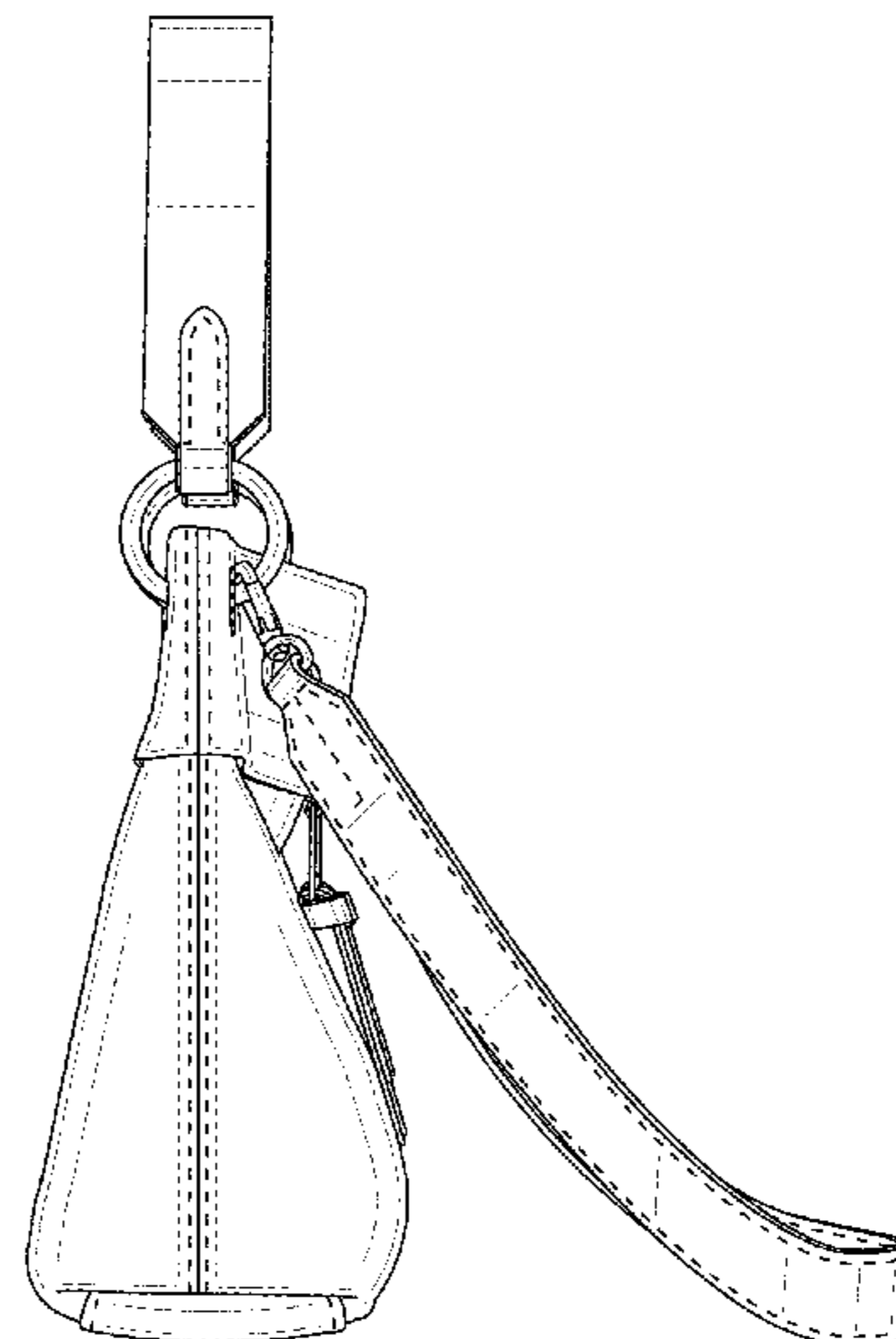

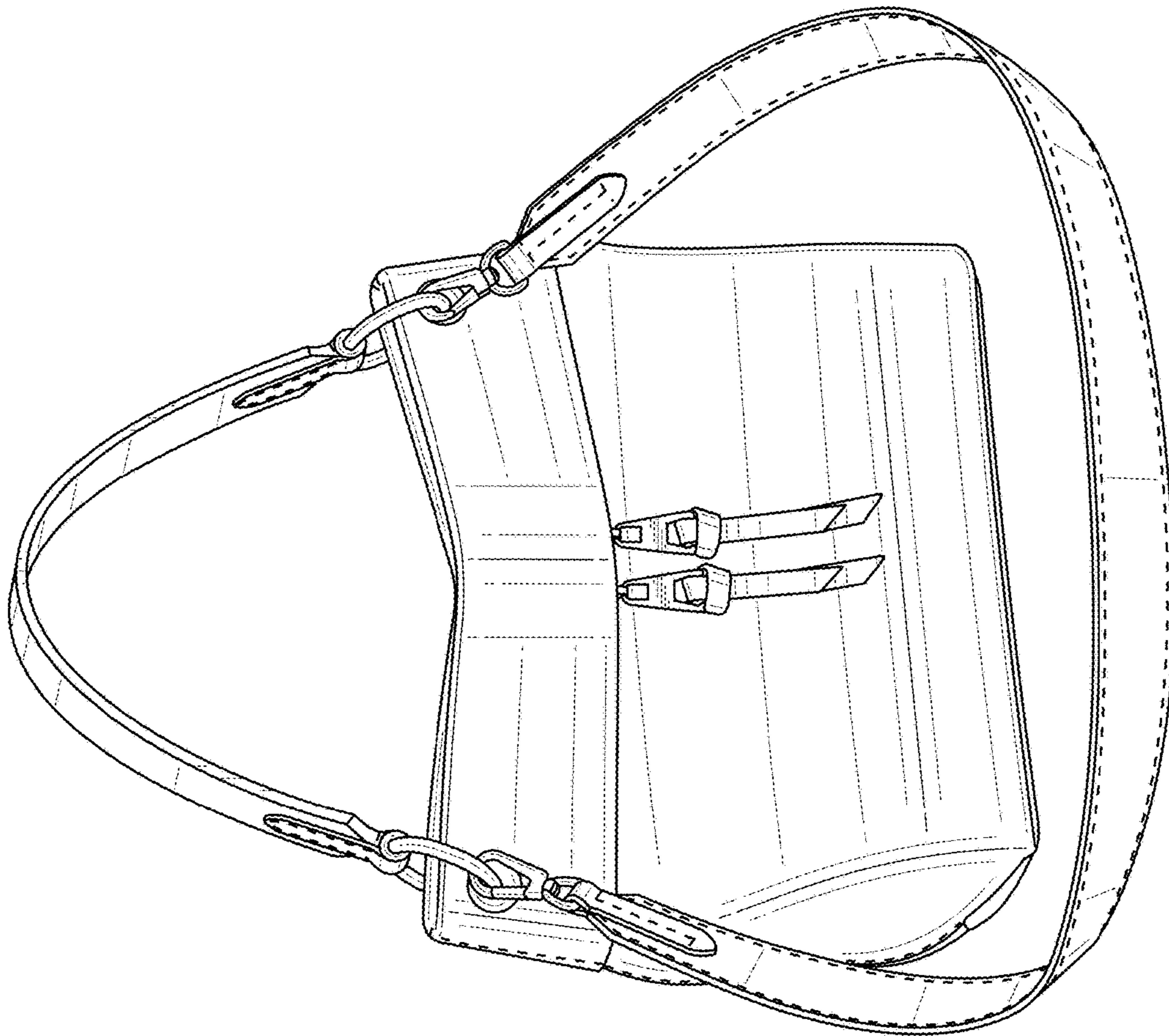

**FIG. 1**

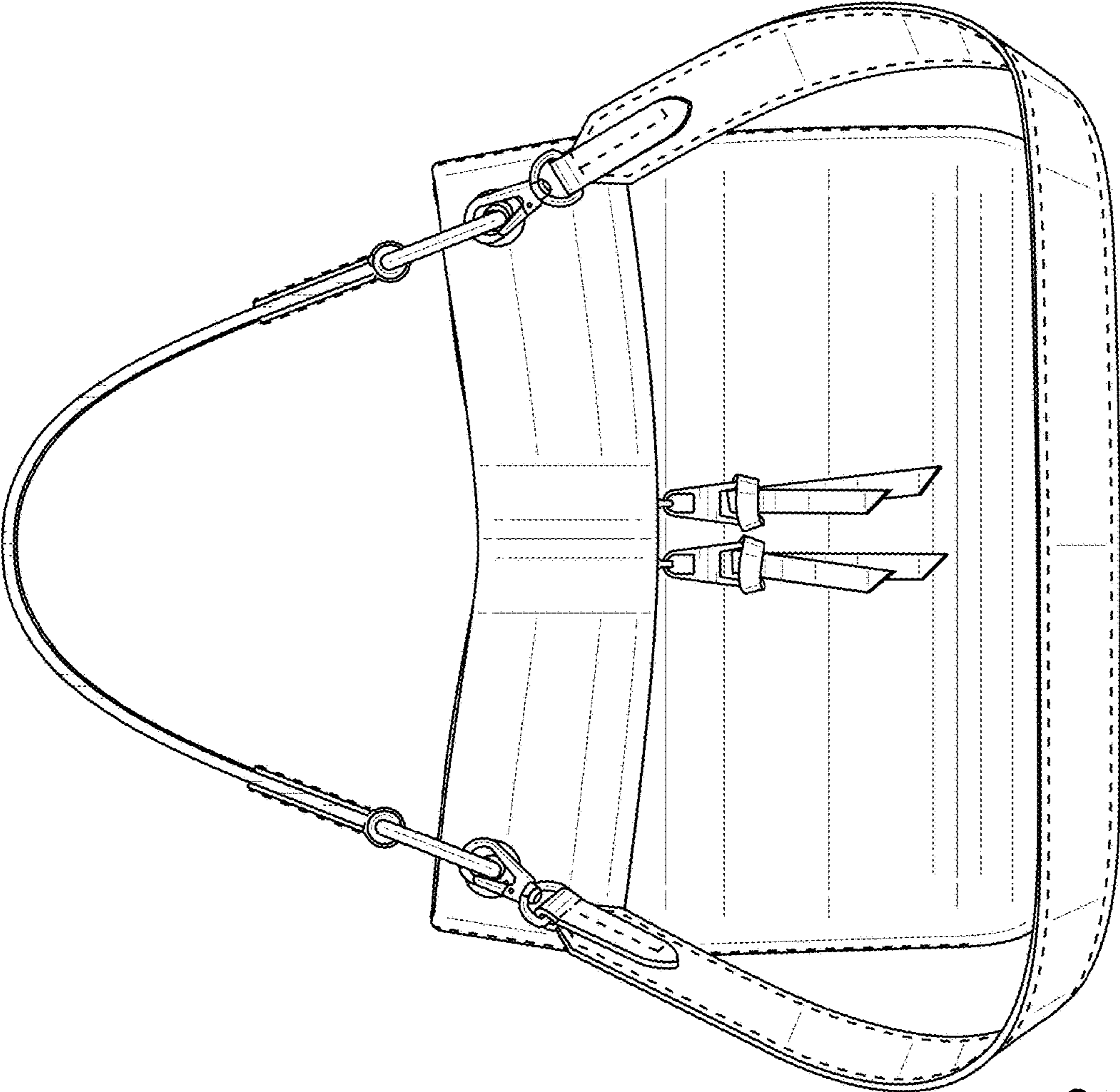
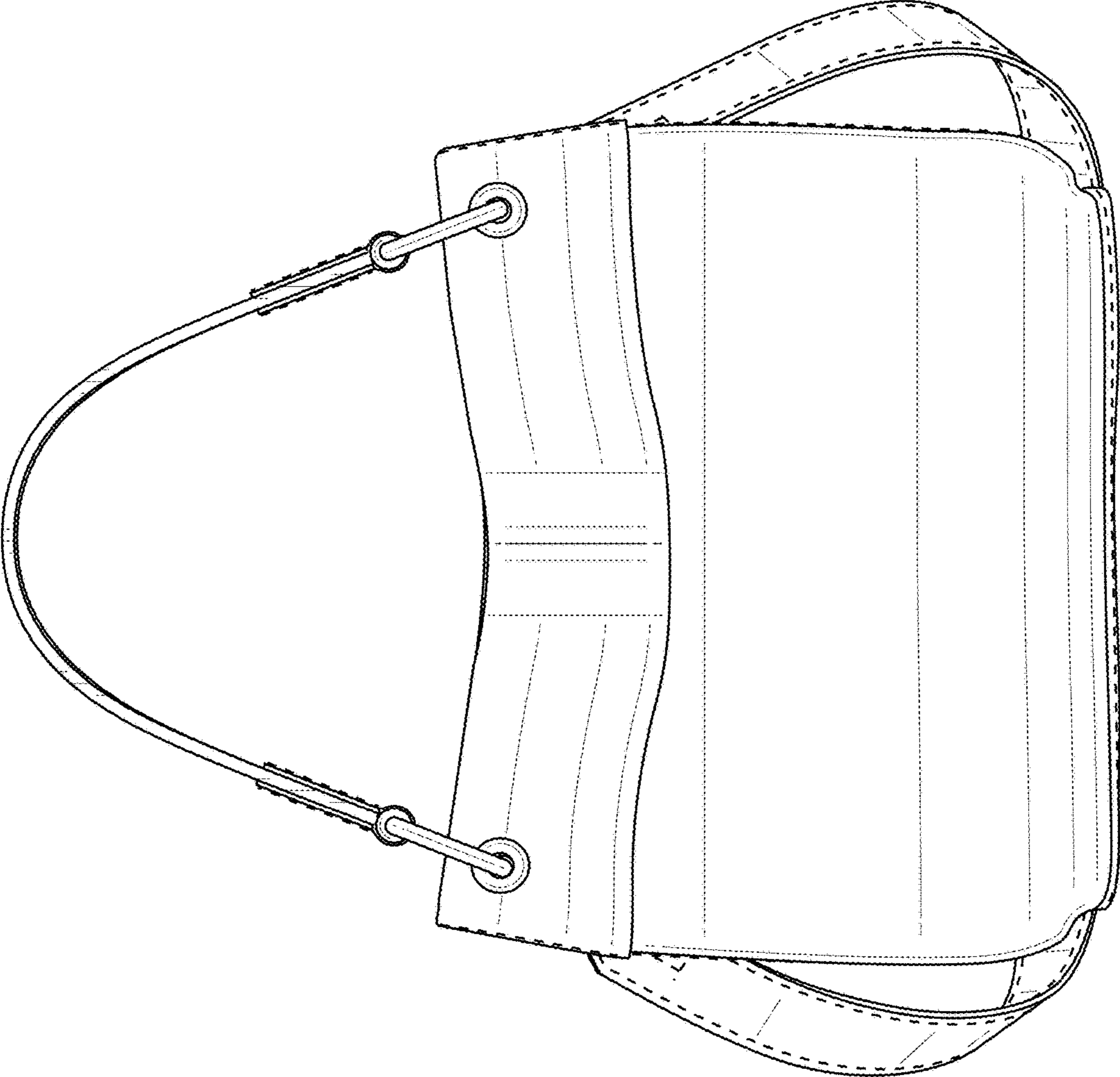
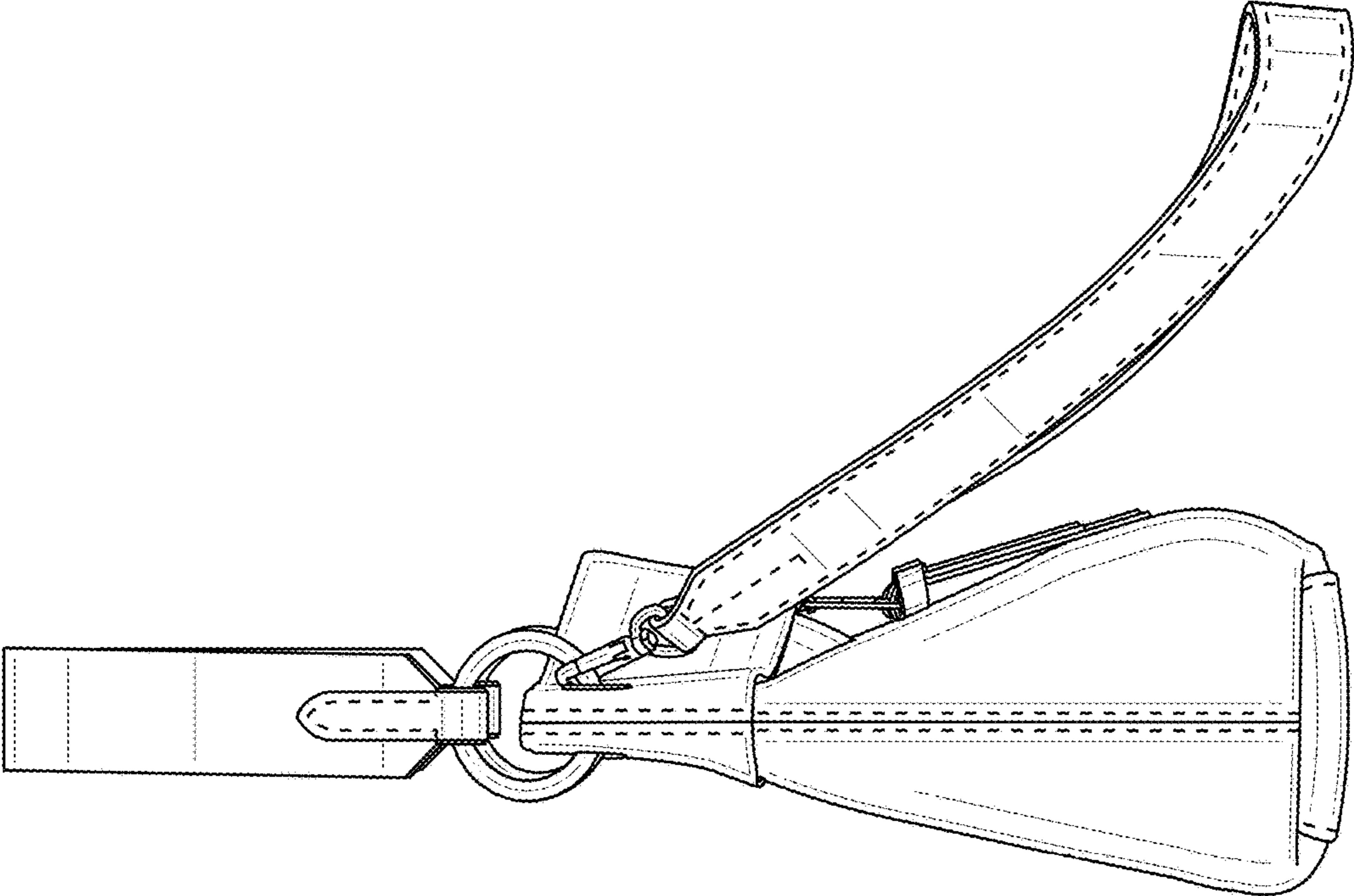

FIG. 2



**FIG. 3**



**FIG. 4**

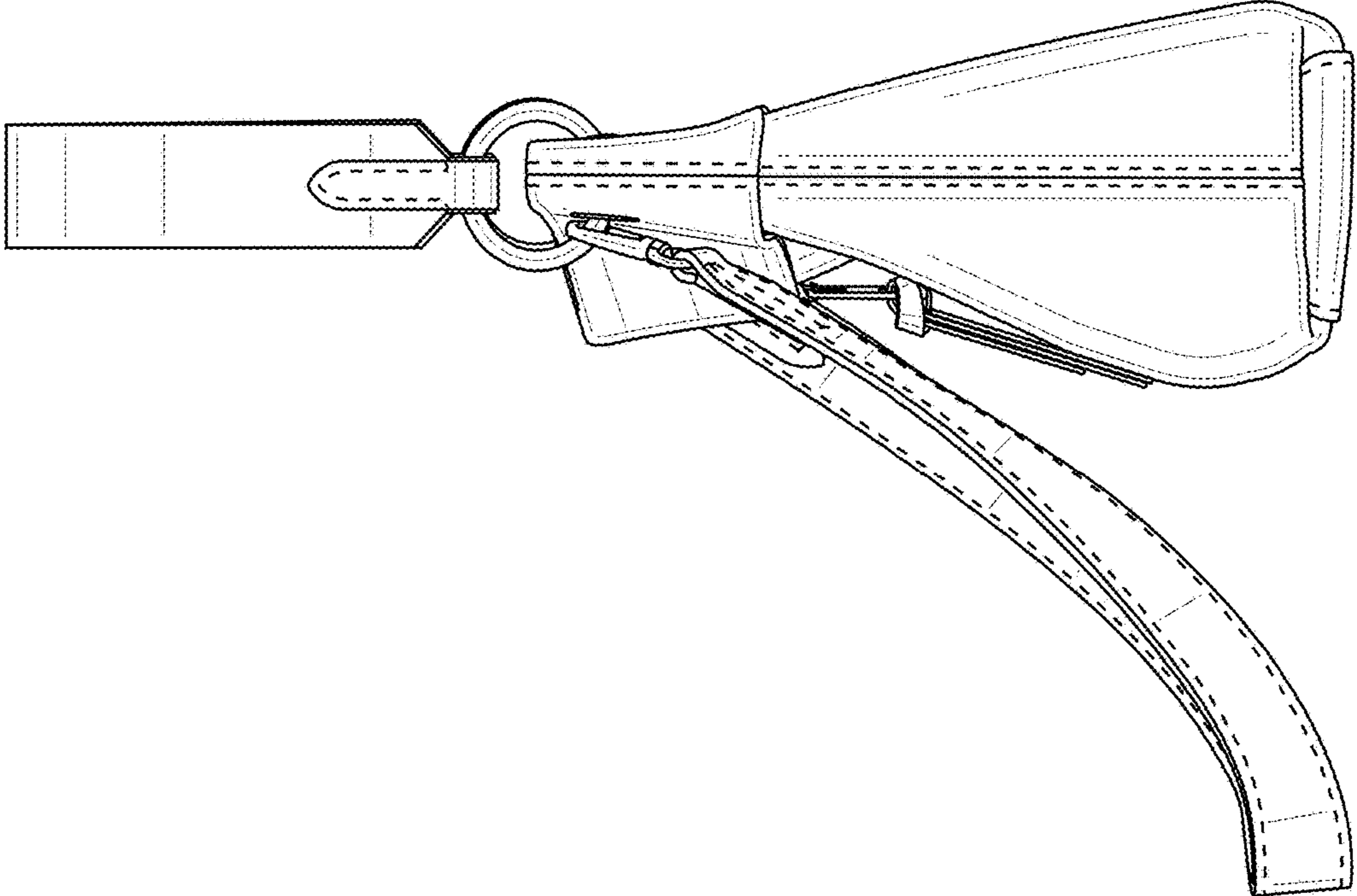

**FIG. 5**

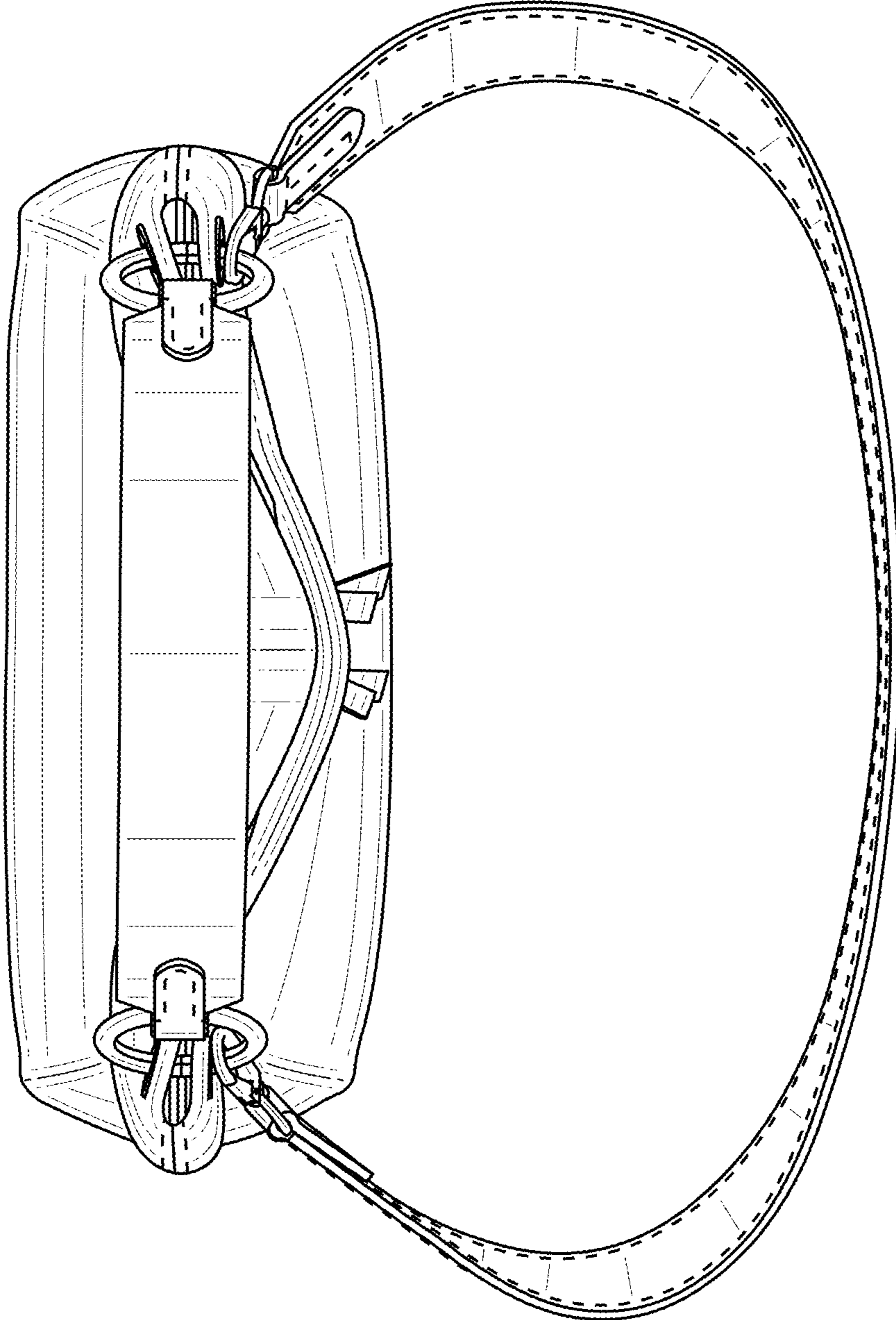

**FIG. 6**

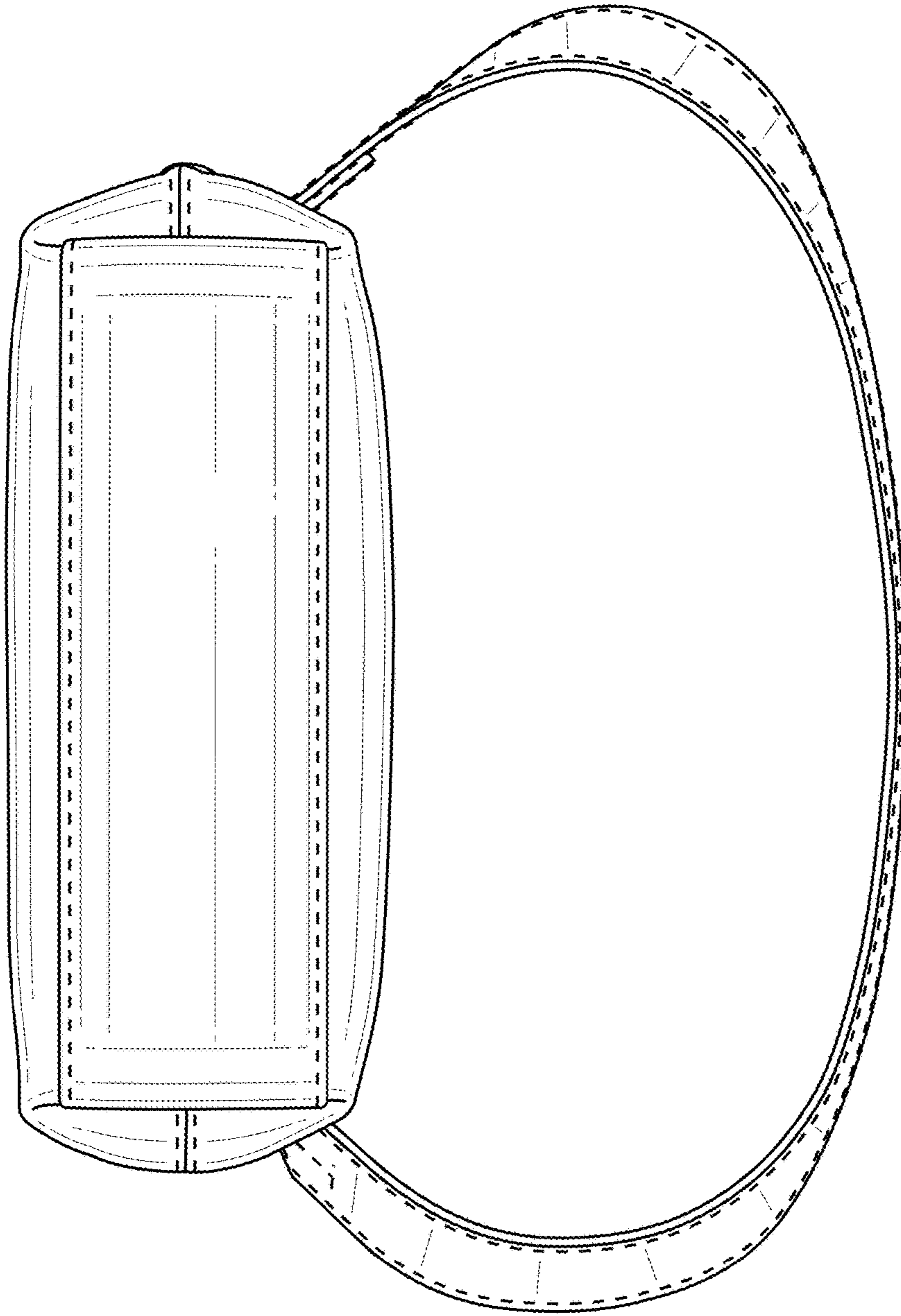

**FIG. 7**