



US00D818046S

(12) **United States Design Patent** (10) **Patent No.:** **US D818,046 S**
Benini et al. (45) **Date of Patent:** **** May 15, 2018**

(54) **VISUAL LANDING TARGET**
(71) Applicant: **Colorado Seminary Which Owns and Operates the University of Denver**, Denver, CO (US)
(72) Inventors: **Alessandro Benini**, Denver, CO (US); **Matthew J. Rutherford**, Denver, CO (US); **Kimon P. Valavanis**, Denver, CO (US)

4,470,818 A * 9/1984 Marshall F41G 3/2611
273/348.1
4,700,912 A * 10/1987 Corbett B64F 1/00
244/110 E
4,890,802 A * 1/1990 Burgess B64F 1/125
244/100 R
6,193,190 B1 2/2001 Nance
D567,296 S * 4/2008 Kharitonova D21/302
(Continued)

(73) Assignee: **Colorado Seminary Which Owns and Operates the University of Denver**, Denver, CO (US)

EP 2518580 A3 10/2012

(**) Term: **15 Years**

(21) Appl. No.: **29/585,482**

(22) Filed: **Nov. 23, 2016**

(51) **LOC (11) Cl.** **21-01**

(52) **U.S. Cl.**
USPC **D21/302**

(58) **Field of Classification Search**
USPC D21/300, 302, 303, 305, 334, 335;
273/348, 336, 398-402, 407, 317, 371.1,
273/343, 367-369, 371, 381, 386;
244/63, 110 E, 114 R; 455/39, 521, 73,
455/575.1; 340/815.4, 286.01, 5.32,
340/426.18, 426.17, 154, 138, 601
CPC A63F 7/06; A63F 3/02; A63F 3/06; A63F
9/02; A63B 67/00; A63B 63/08; A63B
7/00; B64F 1/00; B64F 1/18; B64F 1/20;
B64F 3/00; B64C 15/00; G08G 5/0026
See application file for complete search history.

FOREIGN PATENT DOCUMENTS

OTHER PUBLICATIONS

Yang, et al., "Autonomous Landing of MAVS on an Arbitrarily Textured Landing Site Using Onboard Monocular Vision", "Journal of Intelligent and Robotic Systems", Oct. 25, 2013, pp. 27-43, No. 74, Publisher: Springer Science+Business Media Dordrecht, Published in: GE.

(Continued)

Primary Examiner — Prabhakar G Deshmukh
(74) *Attorney, Agent, or Firm* — Neugeboren O'Dowd PC

(57) **CLAIM**

The ornamental design for a visual landing target, as shown and described.

DESCRIPTION

FIG. 1 is a front elevational view of a visual landing target showing our new design;
FIG. 2 is a front elevational view of a second embodiment of a visual landing target thereof;
FIG. 3 is a left side elevational view of FIGS. 1 and 2;
FIG. 4 is a bottom plan view of FIGS. 1 and 2;
FIG. 5 is a top plan view of FIGS. 1 and 2; and,
FIG. 6 is a right side elevational view of FIGS. 1 and 2.
The broken lines which define the bounds of the claimed design form no part thereof.

1 Claim, 3 Drawing Sheets

(56) **References Cited**

U.S. PATENT DOCUMENTS

4,260,160 A * 4/1981 Ejnell F41J 2/02
250/503.1
4,346,901 A * 8/1982 Booth F41J 2/02
219/548

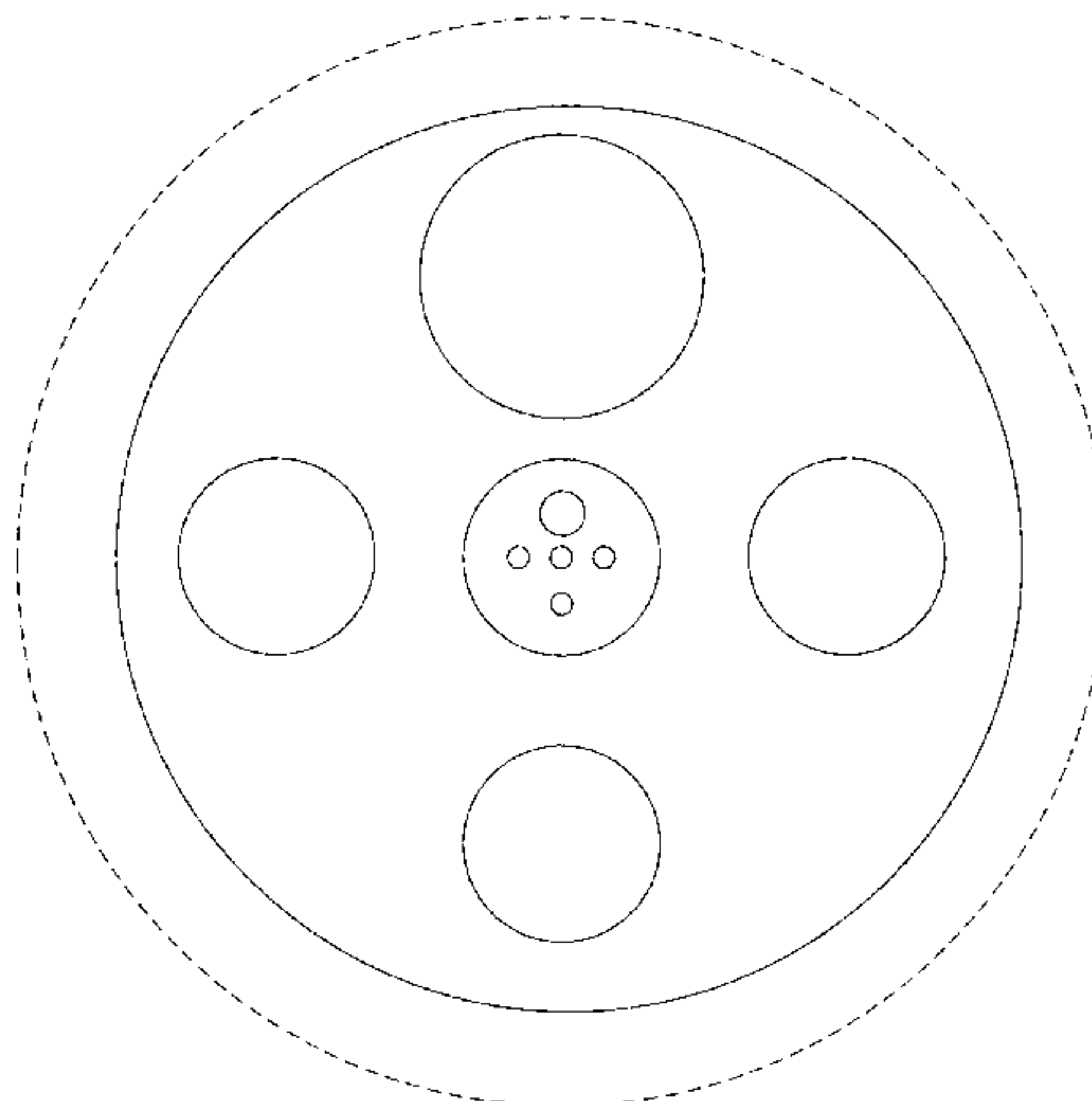

(56)

References Cited

U.S. PATENT DOCUMENTS

D599,412 S * 9/2009 Sandman D21/301
 7,857,450 B1 * 12/2010 Hofeldt A61B 3/022
 351/233
 8,297,552 B2 * 10/2012 Ying B64F 1/005
 244/110 E
 D721,137 S * 1/2015 Sindaco D21/303
 D781,959 S * 3/2017 Thur D21/302
 2009/0306840 A1 12/2009 Blenkhorn et al.

OTHER PUBLICATIONS

Lee, et al., "Autonomous Landing System for Aerial Mobile Robot Cooperation", "Soft Computing and Intelligent Systems", Dec. 3, 2014, p. 6, Publisher: Institute of Electrical and Electronics Engineers, Published in: JP.
 Cocchioni, et al., "Autonomous Navigation, Landing and Recharge of a Quadrotor Using Artificial Vision", "Unmanned Aircraft Sys-

tems", May 27, 2014, p. 12, Publisher: Institute of Electrical and Electronics Engineers, Published in: EP.

Masselli, et al., "A Cross-Platform Comparison of Visual Marker Based Approaches for Autonomous Flight of Quadcopters", "Journal of Intelligent and Robotic Systems", Oct. 23, 2013, pp. 349-359, No. 73, Publisher: Springer Science+Business Media Dordrecht, Published in: GE.

Li, et al., "Development of an Unmanned Aerial Vehicle for Rooftop Landing and Surveillance", "Unmanned Aircraft Systems", Jun. 9, 2015, p. 7, Publisher: Institute of Electrical and Electronics Engineers, Published in: SP.

Jung, et al., "Study on Ellipse Fitting Problem for Vision-Based Autonomous Landing of an VA V", "Control, Automation and Systems", Oct. 22, 2014, p. 4, Publisher: Institute of Electrical and Electronics Engineers, Published in: KR.

Lange, et al., "A Vision Based Onboard Approach for Landing and Position Control of an Autonomous Multirotor UAV in GPS-Denied Environments", "Advanced Robotics", Jun. 22, 2009, p. 6, Publisher: Institute of Electrical and Electronics Engineers, Published in: GE.

* cited by examiner

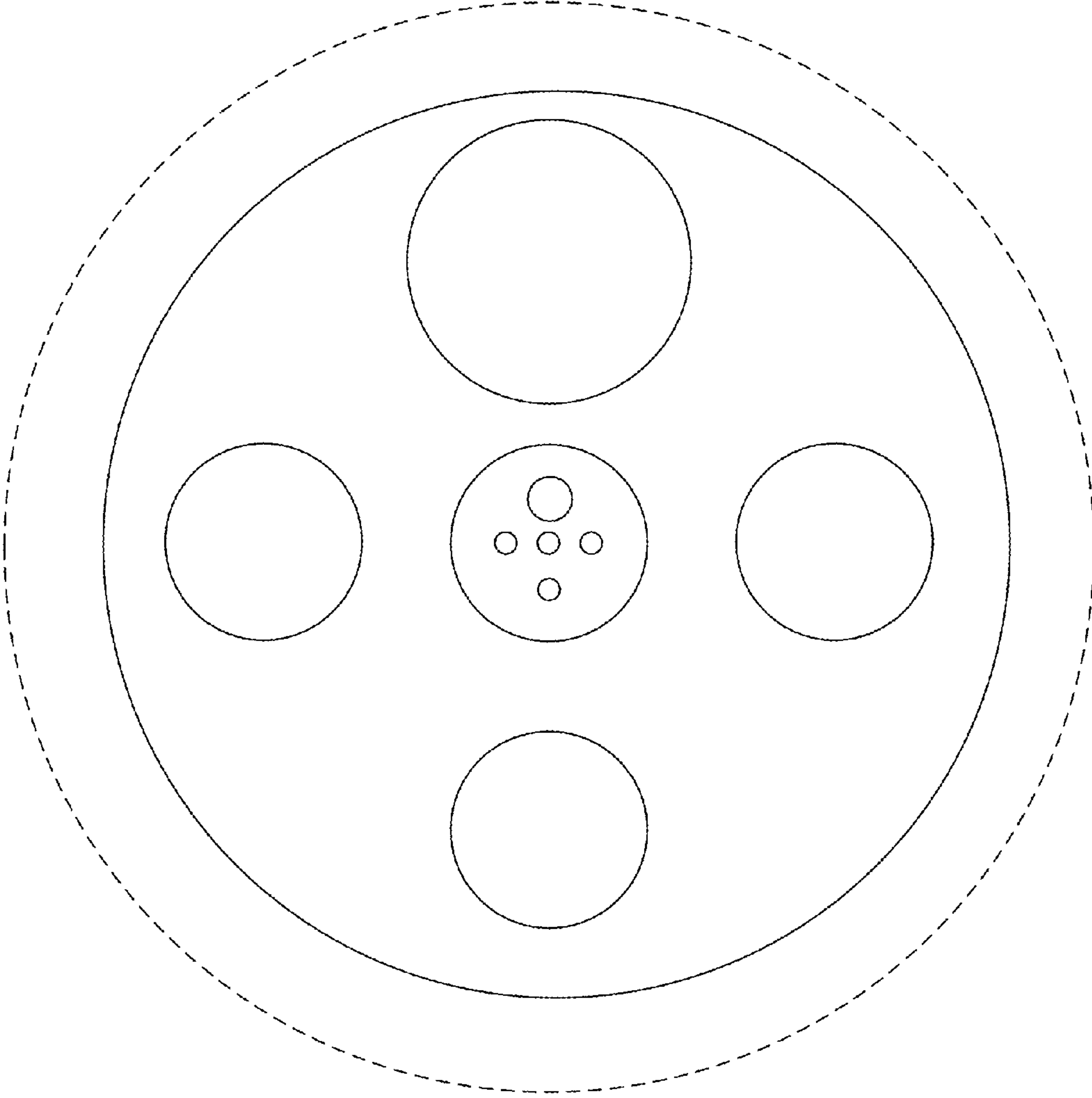

FIG. 1

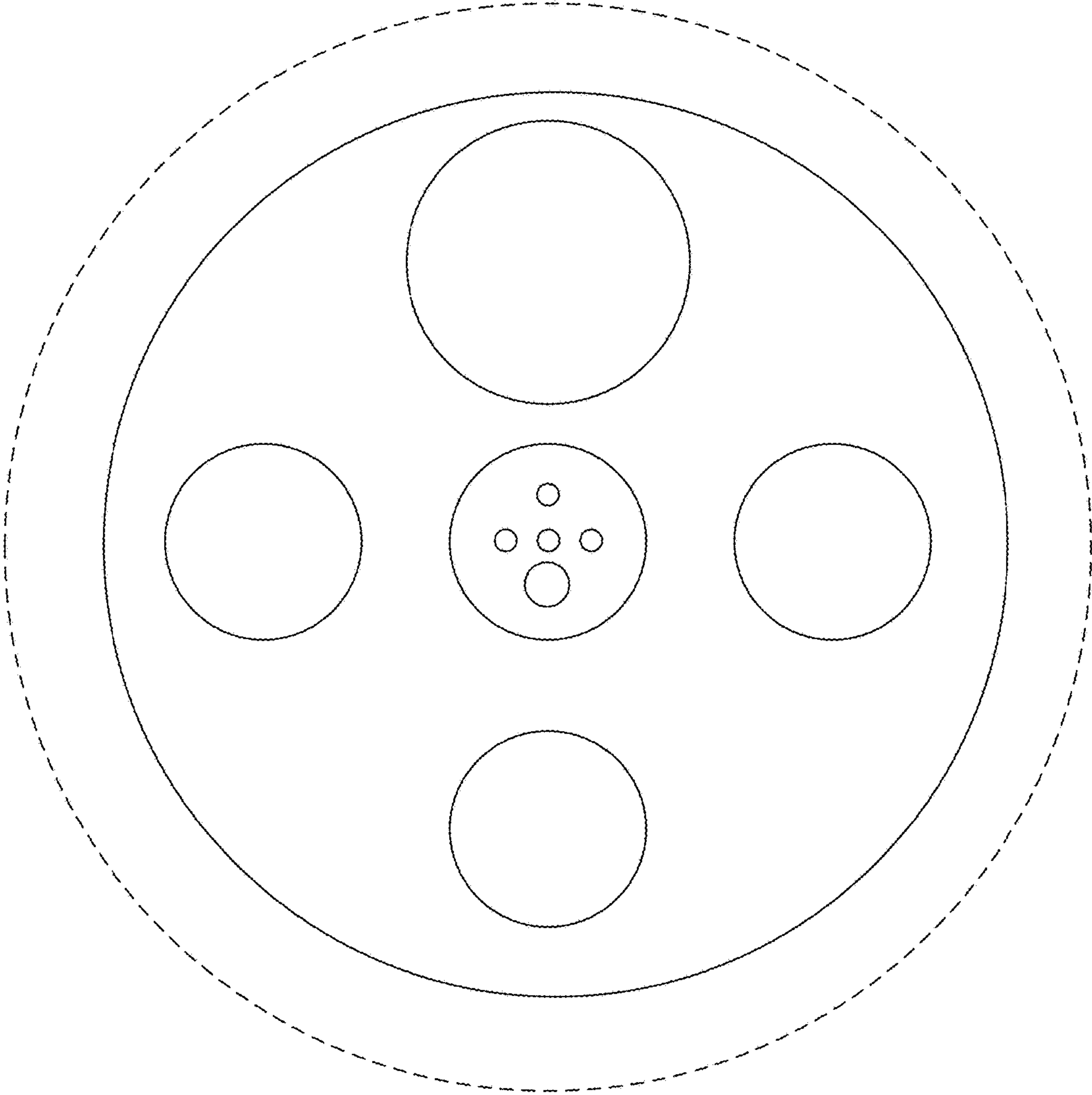

FIG. 2



FIG. 5



FIG. 3

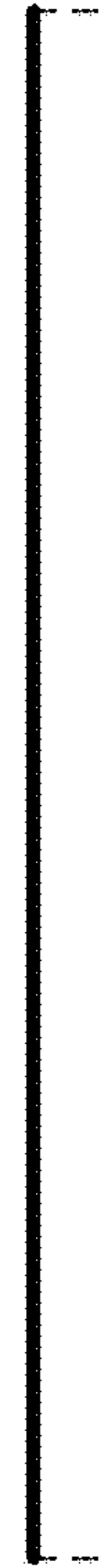

FIG. 6

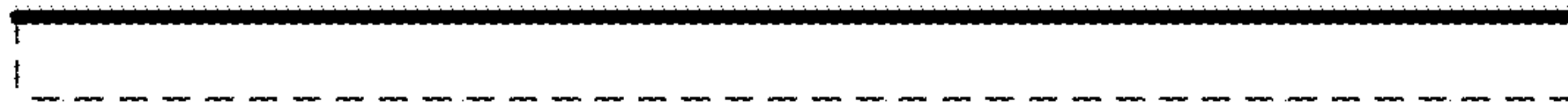

FIG. 4