



US00D817939S

(12) **United States Design Patent** (10) **Patent No.:** **US D817,939 S**
Cho et al. (45) **Date of Patent:** **** May 15, 2018**

(54) **STAND FOR TELEVISION RECEIVER**

(71) Applicant: **Samsung Electronics Co., Ltd.**,
Suwon-si (KR)

(72) Inventors: **Chulyong Cho**, Seoul (KR); **Sin-Wi Moon**, Seoul (KR); **Jaeneung Lee**,
Ansan-si (KR)

(73) Assignee: **Samsung Electronics Co., Ltd.**,
Suwon-si (KR)

(**) Term: **15 Years**

(21) Appl. No.: **29/595,419**

(22) Filed: **Feb. 28, 2017**

(30) **Foreign Application Priority Data**

Sep. 1, 2016 (KR) 30-2016-0043093

(51) **LOC (11) Cl.** **14-03**

(52) **U.S. Cl.**
USPC **D14/239**; D14/126

(58) **Field of Classification Search**
USPC D14/125-134, 239, 371, 136, 374-377,
D14/440, 450, 448, 336, 342, 159;
312/7.2; 348/836, 838, 180, 184, 325,
348/739; 248/917-924, 465; 345/104,
345/133, 156, 168, 87, 173; D21/329,
D21/515, 577, 622, 333, 433, 448, 452,
D21/450, 331, 505; D10/15, 26;
446/484, 175, 356; D6/477, 479, 300;
D24/185; D34/14

CPC ... G06F 1/1601; G06F 1/1643; H05K 5/0004;
H05K 5/0017; H05K 5/02; H05K 5/0217

See application file for complete search history.

(56) **References Cited**

U.S. PATENT DOCUMENTS

D743,953 S	*	11/2015	Ann	D14/239
D745,864 S	*	12/2015	Jung	D14/239
D760,706 S	*	7/2016	Son	D14/239

* cited by examiner

Primary Examiner — Randall H Gholson

(74) *Attorney, Agent, or Firm* — NSIP Law

(57) **CLAIM**

We claim the ornamental design for a stand for television receiver, as shown and described.

DESCRIPTION

FIG. 1 is a front perspective view of a stand for television receiver showing our new design;
 FIG. 2 is a front view thereof;
 FIG. 3 is a rear view thereof;
 FIG. 4 is a left-side view thereof;
 FIG. 5 is a right-side view thereof;
 FIG. 6 is a top view thereof;
 FIG. 7 is a bottom view thereof;
 FIG. 8 is a rear perspective view thereof; and,
 FIG. 9 is a front perspective view thereof shown in an example environment.

The dot-dash broken lines in the figures represent a boundary of the claimed design. The dash-dash broken lines in the figures depict environmental subject matter. The broken lines form no part of the claimed design.

1 Claim, 8 Drawing Sheets

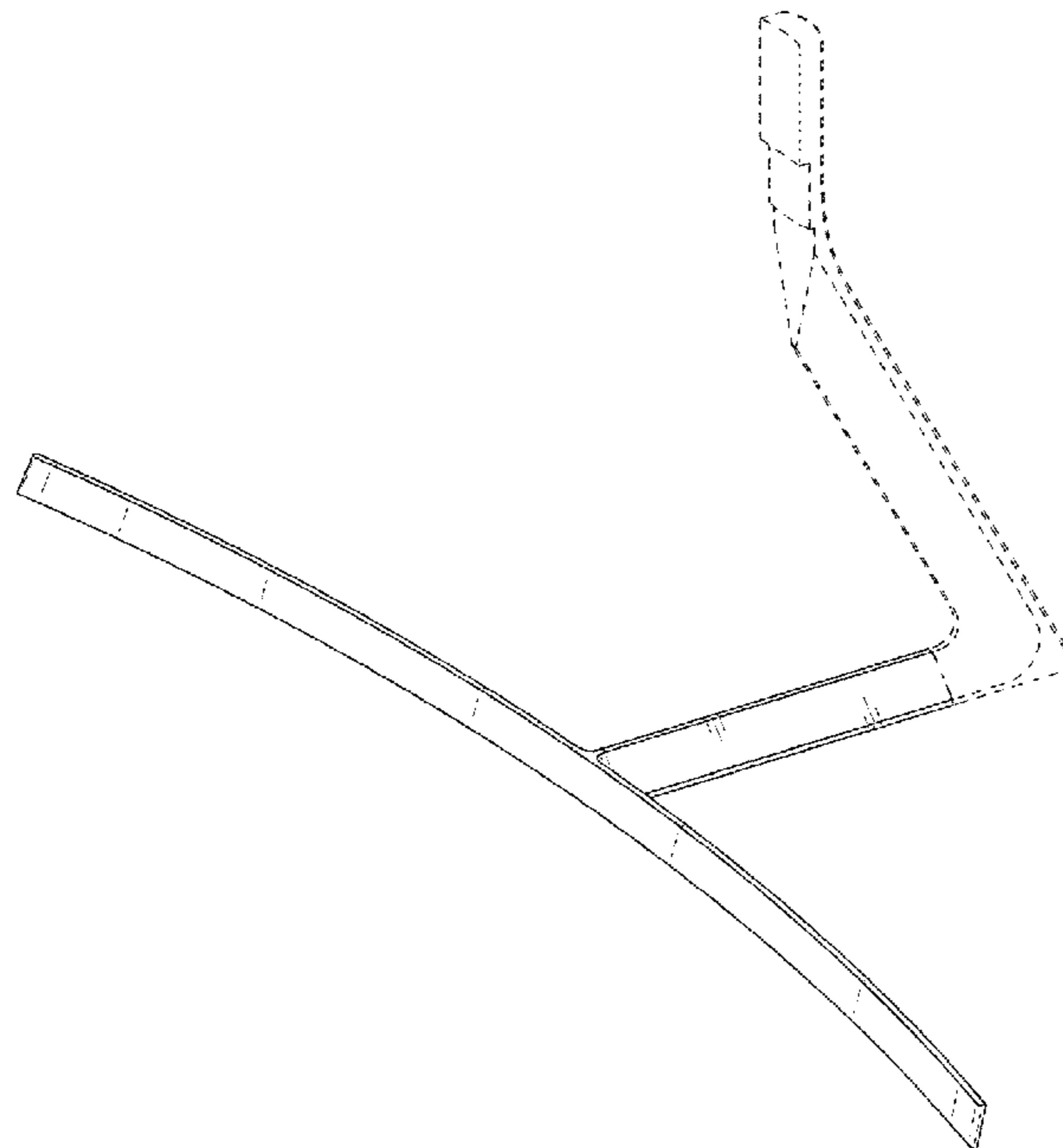

FIG. 1

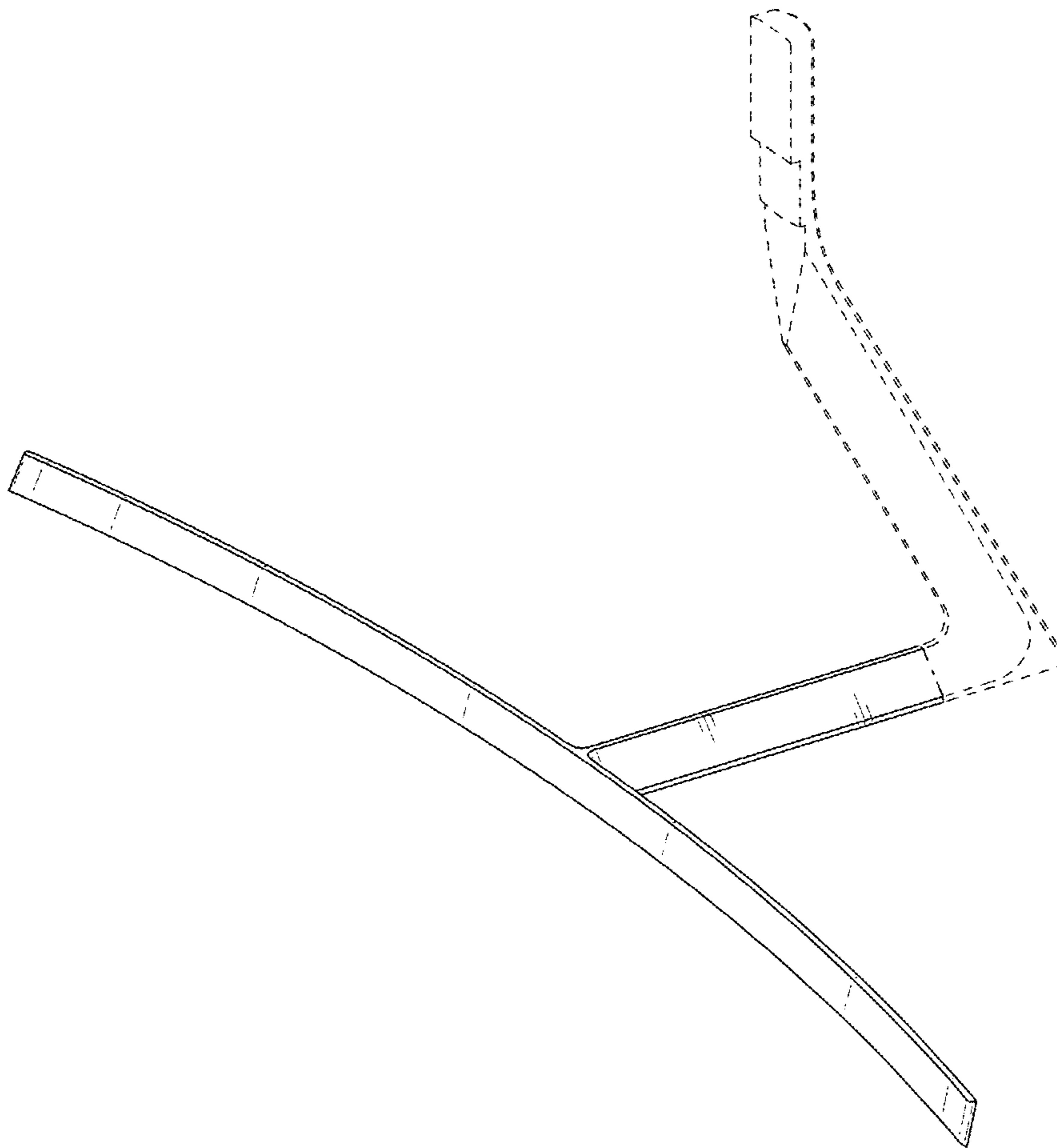

FIG. 2

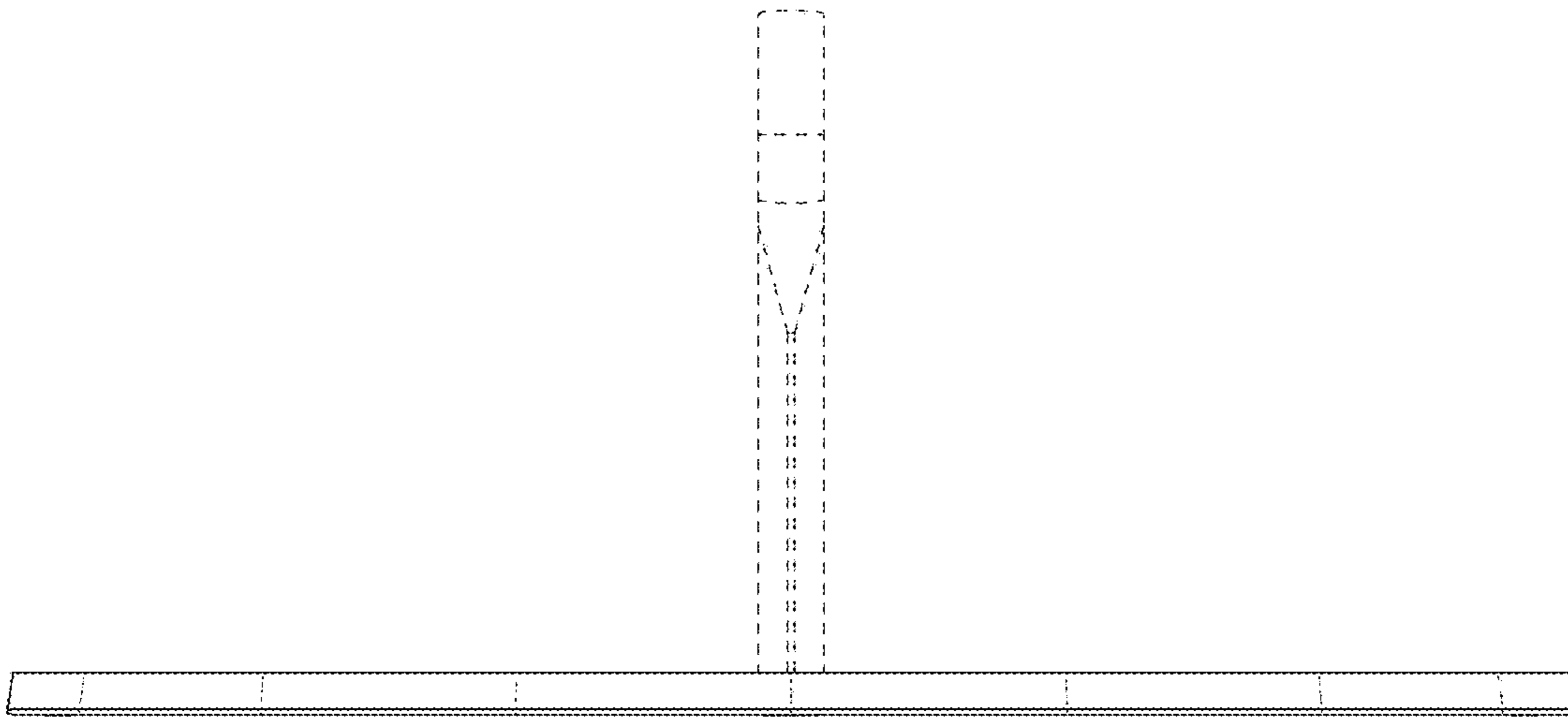

FIG. 3

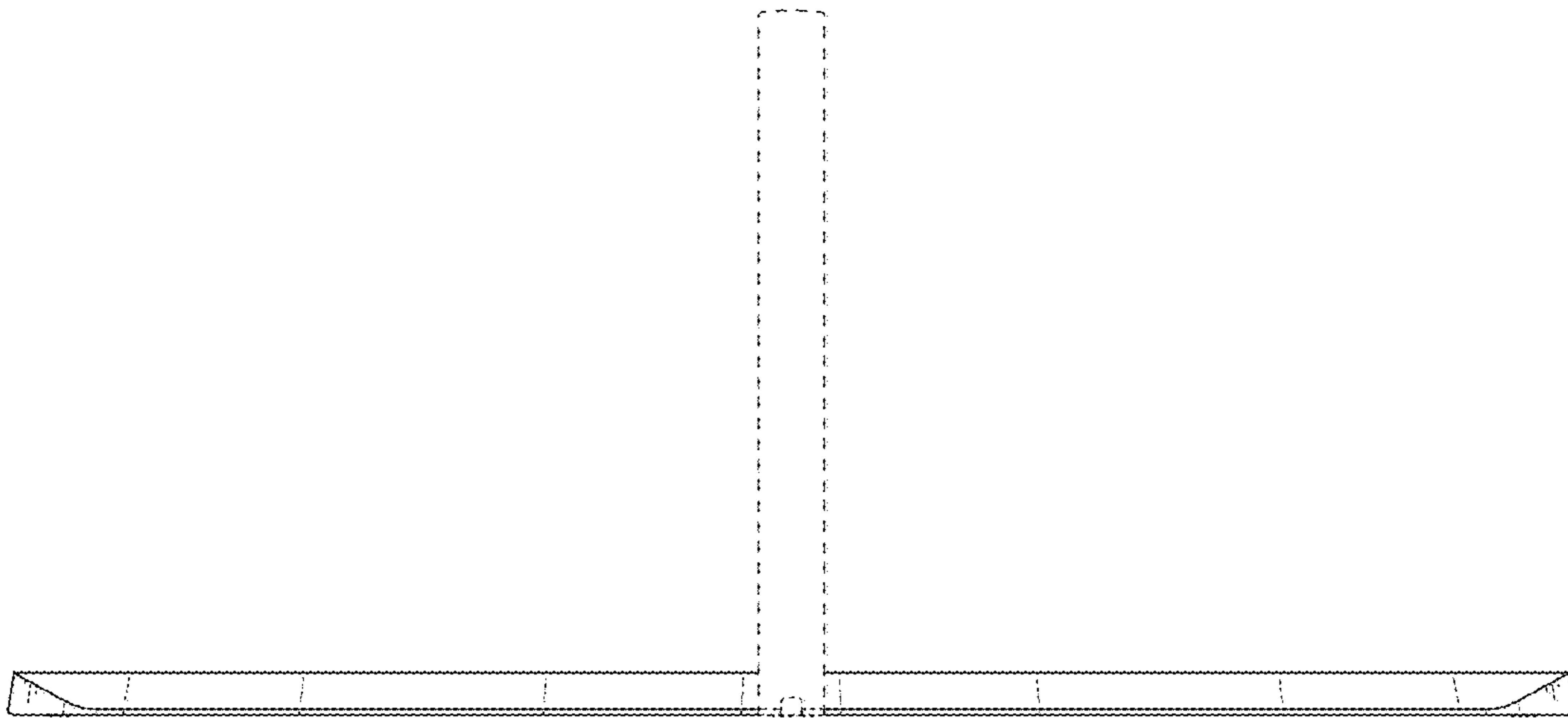

FIG. 4

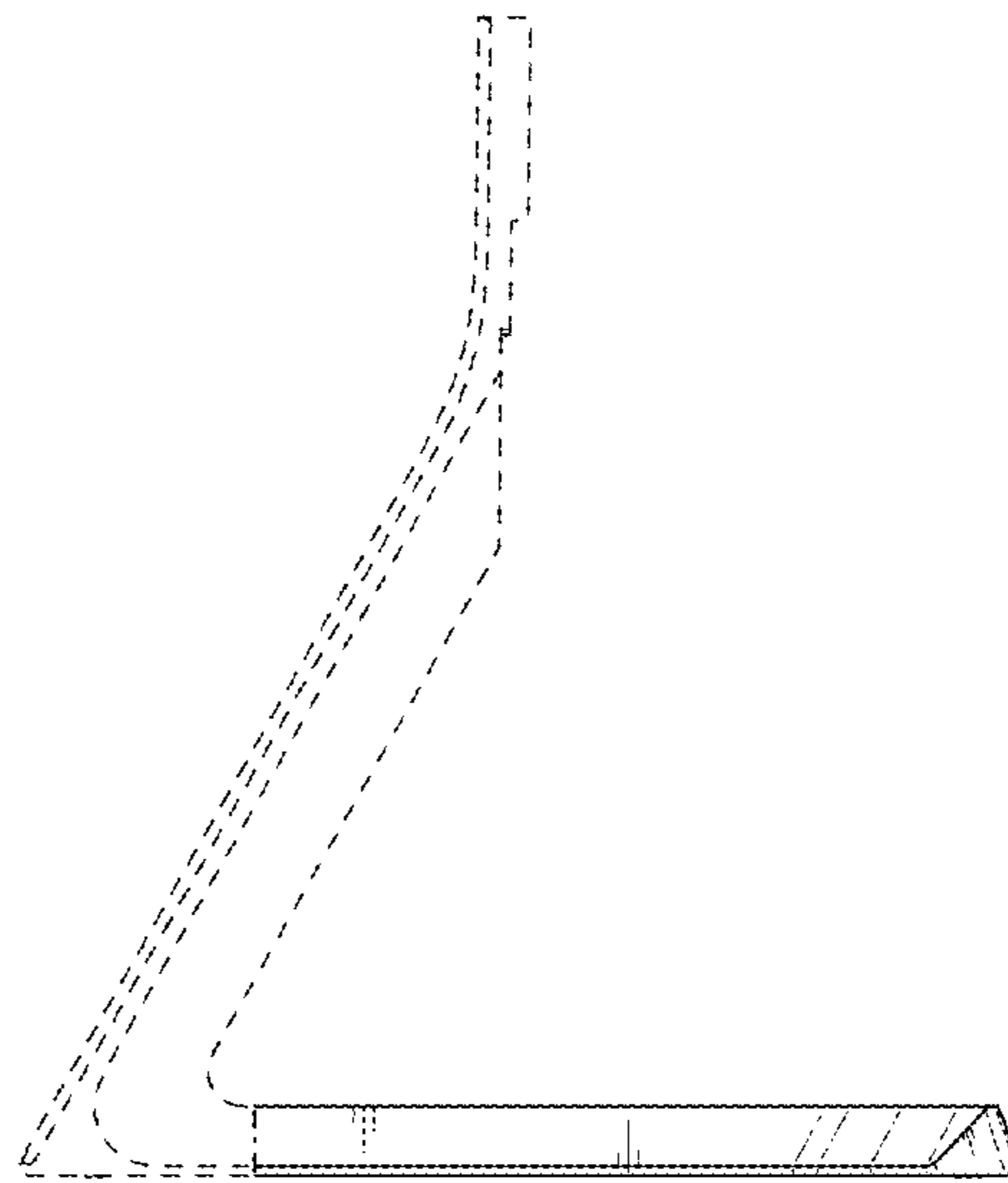

FIG. 5

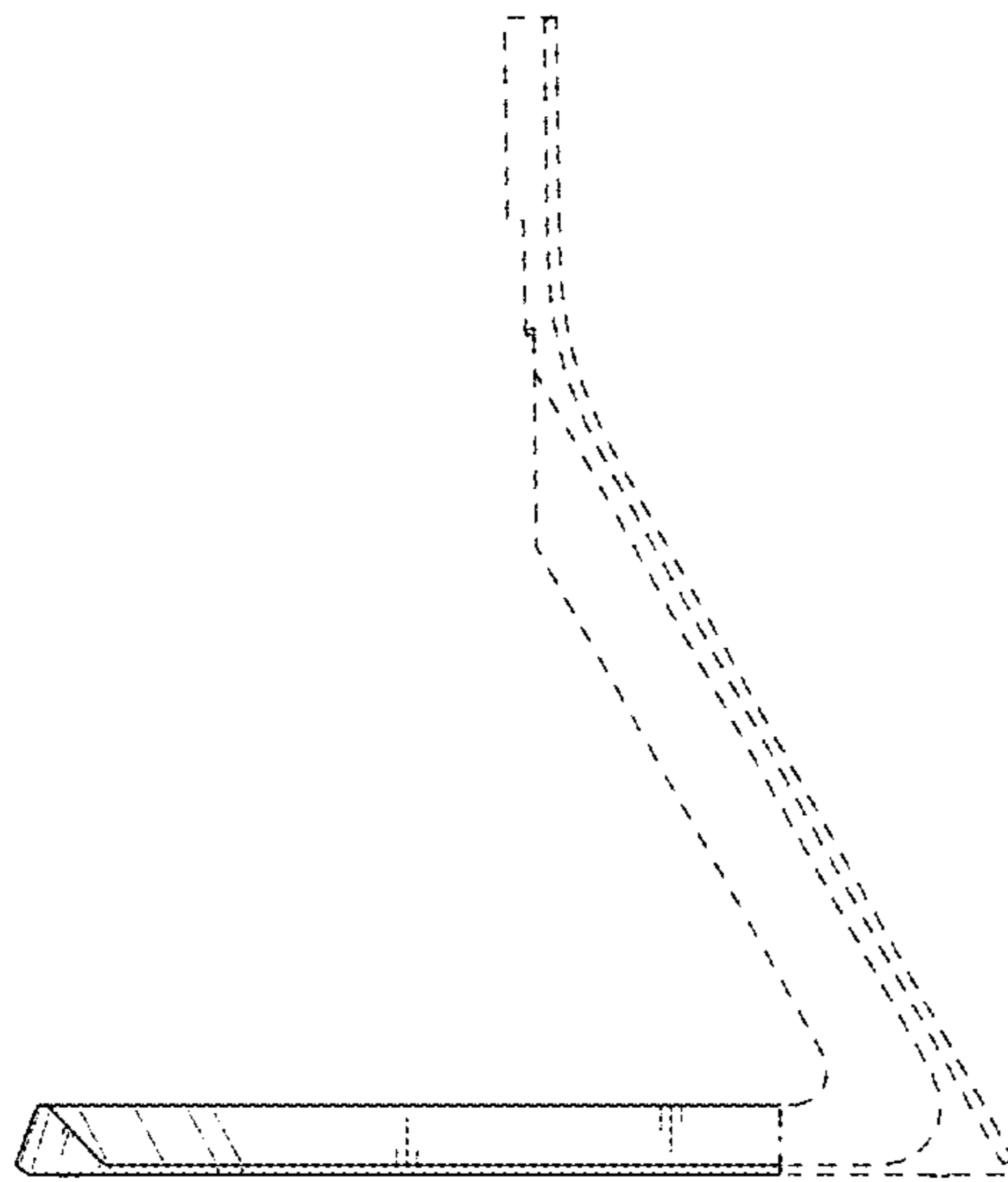

FIG. 6

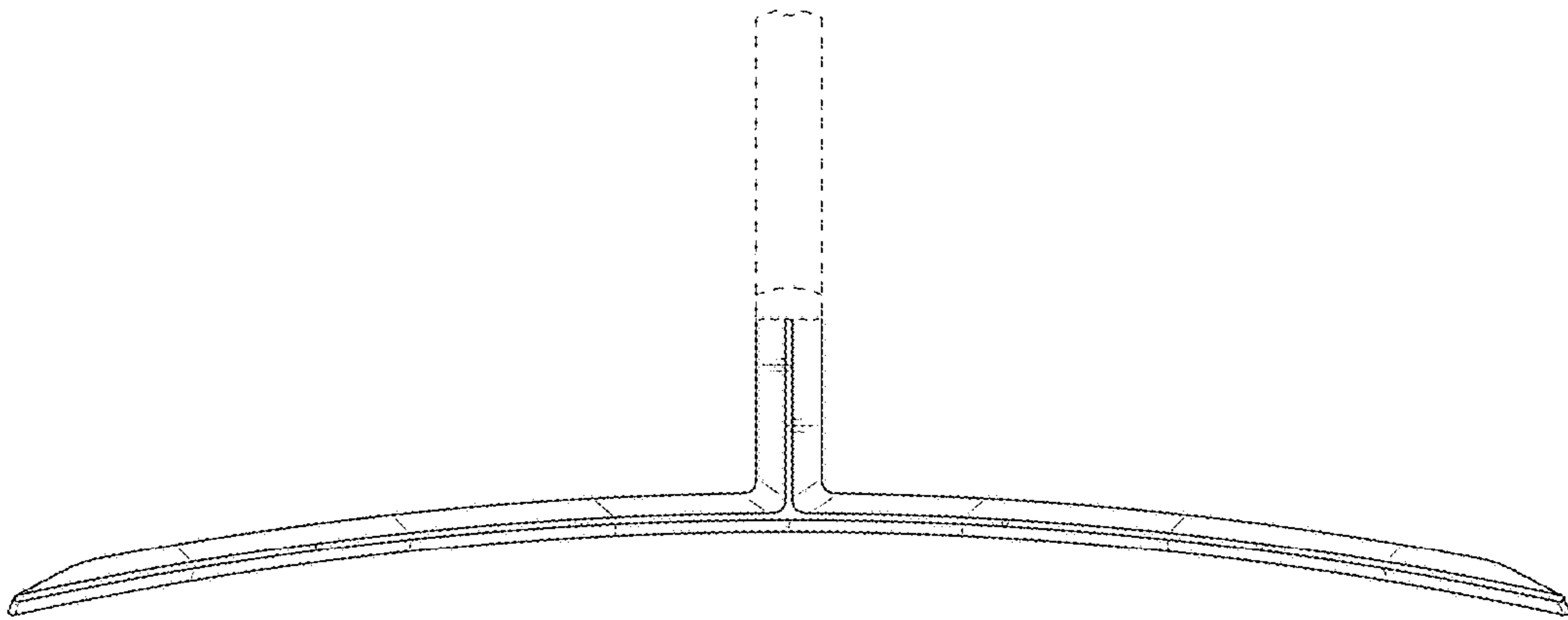

FIG. 7

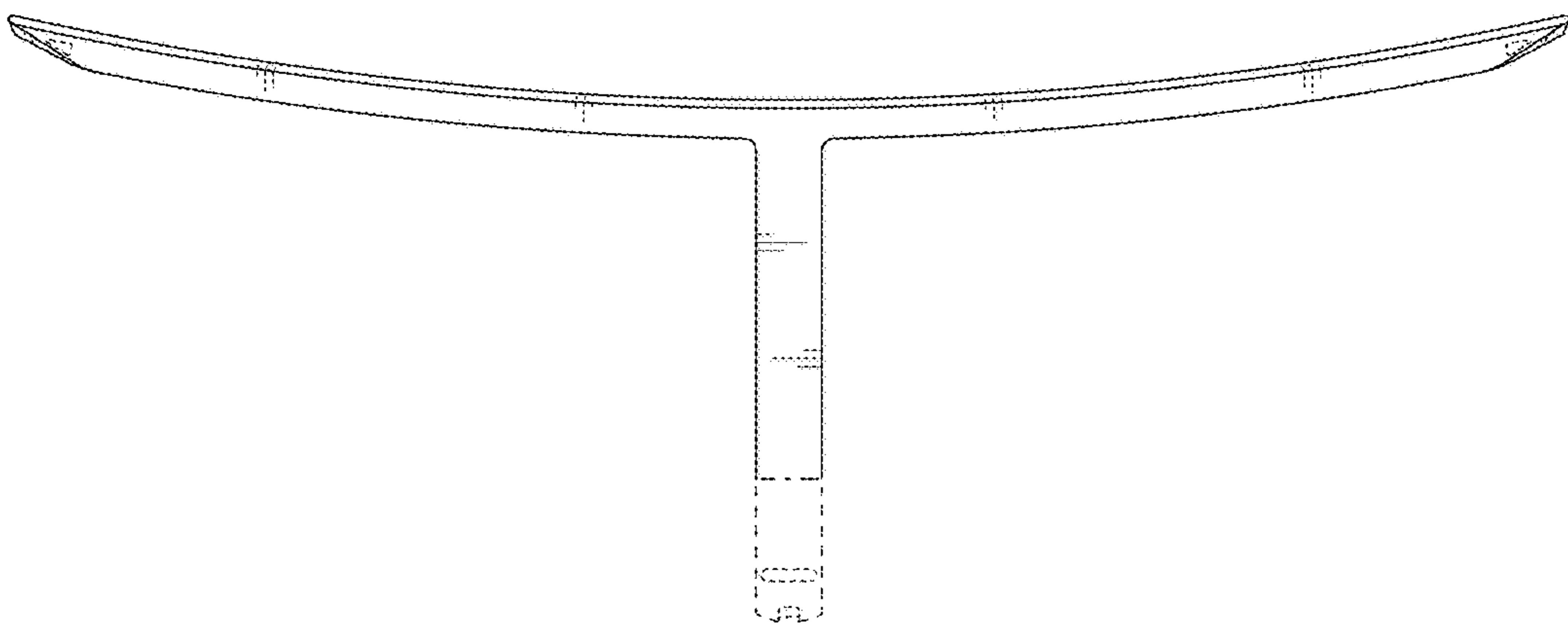

FIG. 8

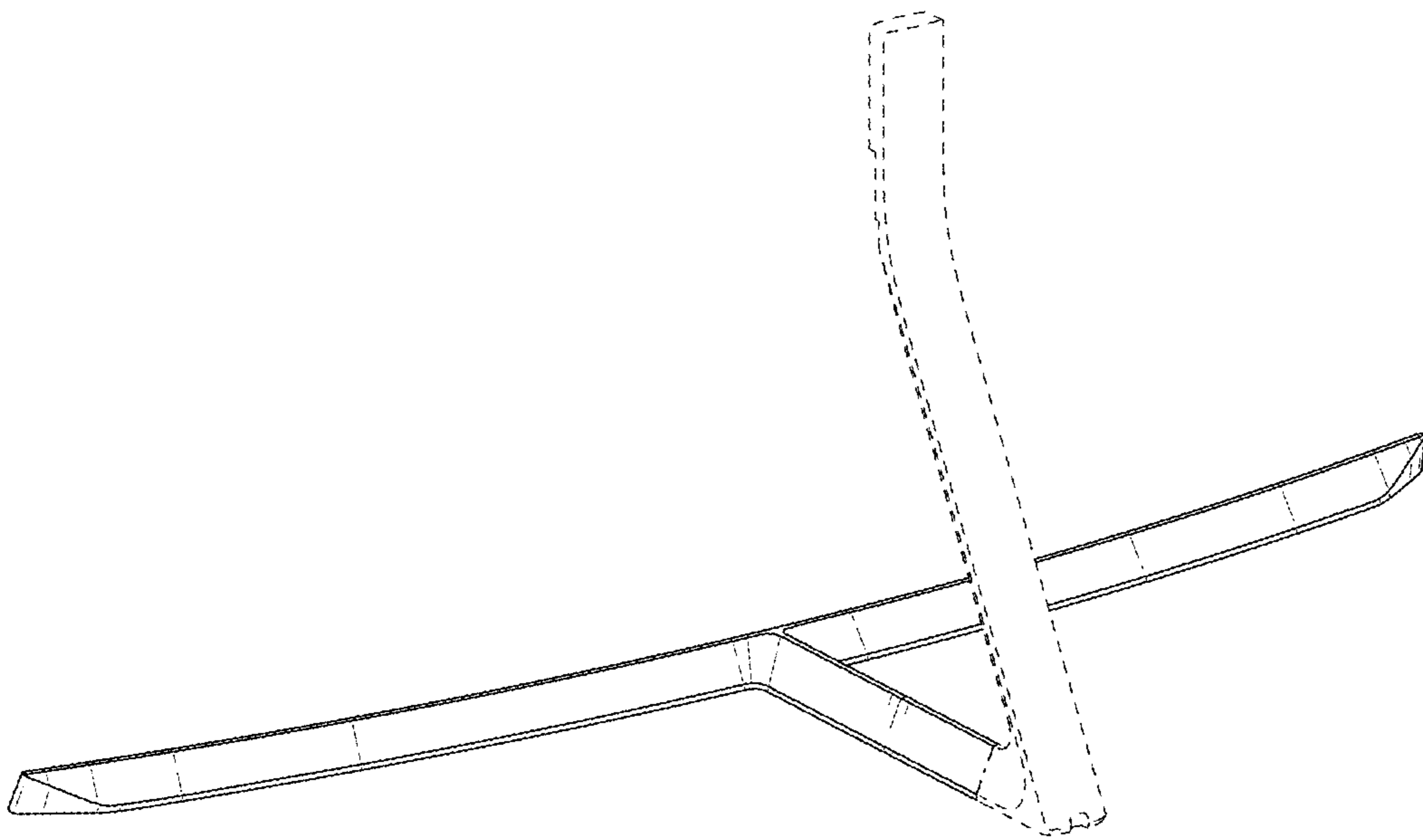

FIG. 9

