



US00D817827S

(12) **United States Design Patent** (10) **Patent No.:** **US D817,827 S**
Zeptner (45) **Date of Patent:** **** May 15, 2018**

(54) **HEAVY TRUCK FENDER BRACKET**

(71) Applicant: **Travis Zeptner**, Fort Worth, TX (US)

(72) Inventor: **Travis Zeptner**, Fort Worth, TX (US)

(73) Assignee: **PACCAR Inc**, Bellevue, WA (US)

(**) Term: **15 Years**

(21) Appl. No.: **29/565,171**

(22) Filed: **May 18, 2016**

(51) **LOC (11) Cl.** **12-08**

(52) **U.S. Cl.**
USPC **D12/181**

(58) **Field of Classification Search**
USPC D12/202, 213, 223, 400, 196, 184, 181;
D8/14, 349, 382, 499
CPC B62D 35/00; B62D 35/001; B62D 35/005;
B62D 35/007; B62D 35/008; B62D
35/02; B62D 25/163; B60R 2019/247
See application file for complete search history.

(56) **References Cited**

U.S. PATENT DOCUMENTS

D160,470 S	*	10/1950	Buerger	454/128
D321,946 S	*	11/1991	Falck	D26/35
D351,820 S	*	10/1994	Knapp, Jr.	D12/190
D388,043 S	*	12/1997	Elwell	D12/100
5,697,644 A		12/1997	Logan et al.	
D401,198 S		11/1998	Mueller et al.	
D412,689 S		8/1999	Onopa	

(Continued)

OTHER PUBLICATIONS

“AeroCab,” Kenworth Truck Company, Kirkland, Washington, 1993, 6-page brochure.

(Continued)

Primary Examiner — Sandra S Snapp

Assistant Examiner — Ieisha N Price

(74) *Attorney, Agent, or Firm* — Christensen O’Connor Johnson Kindness PLLC

(57) **CLAIM**

The ornamental design for a heavy truck fender bracket, as shown and described.

DESCRIPTION

FIG. 1 is a perspective view of a heavy truck fender bracket according to a first embodiment of our new design; FIG. 2 is a front elevational view of the heavy truck fender bracket of FIG. 1; FIG. 3 is a right side elevational view of the heavy truck fender bracket of FIG. 1; FIG. 4 is a left side elevational view of the heavy truck fender bracket of FIG. 1; FIG. 5 is a top plan view of the heavy truck fender bracket of FIG. 1; FIG. 6 is a bottom plan view of the heavy truck fender bracket of FIG. 1; FIG. 7 is a perspective view of a heavy truck fender bracket according to a second embodiment of our new design; FIG. 8 is a front elevational view of the heavy truck fender bracket of FIG. 7; FIG. 9 is a right side elevational view of the heavy truck fender bracket of FIG. 7; FIG. 10 is a left side elevational view of the heavy truck fender bracket of FIG. 7; FIG. 11 is a top plan view of the heavy truck fender bracket of FIG. 7; and, FIG. 12 is a bottom plan view of the heavy truck fender bracket of FIG. 7.

The rear of the heavy truck fender bracket is unornamented. The broken lines shown in the drawings illustrate portions of the heavy truck fender bracket that form no part of the claimed design.

1 Claim, 6 Drawing Sheets

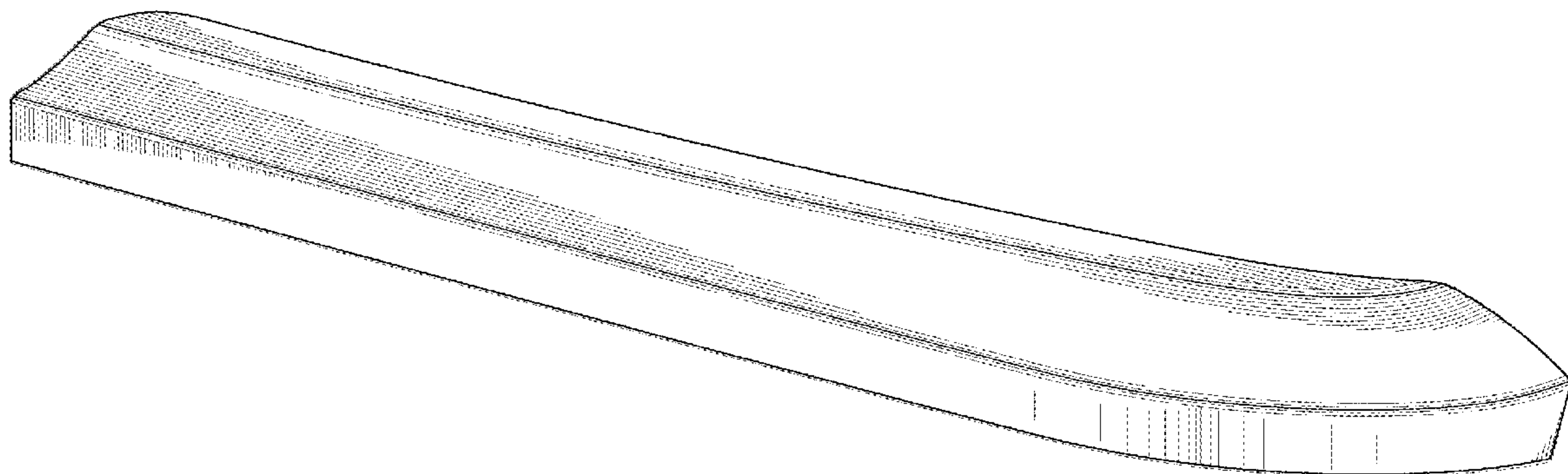

(56)

References Cited

U.S. PATENT DOCUMENTS

5,947,520	A *	9/1999	McHorse	B62D 25/168 280/154
D422,957	S *	4/2000	Damon	D12/196
D424,495	S *	5/2000	Damon	D12/196
D424,496	S *	5/2000	Damon	D12/196
D431,511	S *	10/2000	Damon	D12/196
D478,300	S	8/2003	Chiang		
D483,312	S	12/2003	Saleen		
D484,077	S	12/2003	Conway et al.		
D495,633	S	9/2004	Chiang		
D497,581	S	10/2004	Conway et al.		
D504,642	S	5/2005	Perfetti et al.		
D511,727	S	11/2005	Shaw et al.		
D523,793	S	6/2006	Beigel et al.		
D531,947	S	11/2006	Angelo et al.		
D532,352	S	11/2006	Angelo et al.		
D543,914	S *	6/2007	Lai	D12/181
D545,250	S	6/2007	Angelo et al.		
D545,253	S	6/2007	Jones et al.		
D545,254	S	6/2007	Angelo et al.		
D560,148	S	1/2008	Leclercq		
D560,575	S	1/2008	Simons et al.		
D560,582	S	1/2008	Simons et al.		
D560,583	S	1/2008	Simons et al.		
D561,647	S	2/2008	Simons et al.		
D564,427	S	3/2008	Beigel et al.		
D580,328	S	11/2008	Jones		
D584,667	S	1/2009	Leclercq		
D584,668	S *	1/2009	Raghavendran	D12/184
D591,657	S	5/2009	Golden et al.		
D592,546	S	5/2009	Hammick		
D602,414	S	10/2009	Sunbeam		
D602,415	S	10/2009	Sunbeam		
D602,828	S	10/2009	Sunbeam		
D602,829	S	10/2009	Sunbeam		
D614,102	S *	4/2010	Raghavendran	D12/190
D617,695	S *	6/2010	Lamm	D12/169
D632,224	S	2/2011	Peltola et al.		
D632,234	S	2/2011	Peltola et al.		
D637,536	S *	5/2011	Peltola	D12/190
D647,016	S	10/2011	Medina et al.		
D654,401	S	2/2012	Peltola et al.		
D654,417	S	2/2012	Peltola et al.		
D660,207	S	5/2012	Hanson et al.		
D681,516	S *	5/2013	Jara	D12/169
D684,908	S	6/2013	Lee et al.		
D685,294	S	7/2013	Hanson et al.		
D694,683	S	12/2013	Lee		
D694,684	S	12/2013	Lee		
D694,685	S	12/2013	Lee		
D700,120	S	2/2014	Lee		
D700,552	S	3/2014	Lee		
D700,874	S *	3/2014	Lee	D12/184
D707,164	S	6/2014	Lee		
D710,771	S	8/2014	Hovind et al.		
D736,451	S *	8/2015	Smith	D26/120
D778,795	S *	2/2017	Johns	D12/184
D789,868	S *	6/2017	Enz	D12/400
2007/0187940	A1	8/2007	Presby		
2009/0167011	A1	7/2009	Braga		
2012/0038127	A1	2/2012	Bybee		
2013/0025954	A1	1/2013	Miller et al.		
2013/0193300	A1 *	8/2013	Eklund	B62D 25/188 248/610
2015/0151794	A1	6/2015	Gray		

OTHER PUBLICATIONS

“AeroCab,” Kenworth Truck Company, Kirkland, Washington, as early as 1995, 3-page brochure.
 “AG130 Front Air Suspension,” Kenworth Truck Company, Kirkland, Washington, 2008, 2-page brochure.
 “Class Pays, Truck Models,” Peterbilt Motors Company, Denton, Texas, Mar. 2005, 24-page brochure.

“Construction Trucks,” Canadian Kenworth Truck, Mississauga, Ontario, Canada, Jul. 1990, 16-page brochure.
 “Freightliner Cascadia XT Sleeper,” Mar. 15, 2012, <<http://www.arrowtruckparts.net/servlet/the-90/Freightliner-Columbia-120-Hood/Details>> [retrieved Oct. 12, 2013], 2 pages.
 “Freightliner Columbia 120 Hood,” Jun. 24, 2010, <<http://www.arrowtruckparts.net/servlet/the-90/Freightliner-Columbia-120-Hood/Detail>> [retrieved Oct. 12, 2013], 2 pages.
 Freightliner Custom Chassis: S2 Chassis Shuttle Bus, Sep. 29, 2009, <<http://freightlinerchassis.com/documents/S2SpecSheet-20100127005322000000.pdf>> [retrieved Oct. 12, 2013], 2 pages.
 “Kenworth Truck Models,” Kenworth Truck Company, Kirkland, Washington, 2010, 16-page brochure.
 “Model 357, New Sloped Hood,” Peterbilt Motors Company, Denton, Texas, May 2002, 2-page brochure.
 “PACCAR Engines, 2010 Medium Duty Engines,” PACCAR Inc, Bellevue, Washington, 2010, 6-page brochure.
 “PACCAR MX,” PACCAR Inc, Bellevue, Washington, 2010, 4-page brochure.
 “Studio Sleeper,” Kenworth Truck Company, Kirkland, Washington, 1993, 5-page brochure.
 “T170 Class 5,” Kenworth Truck Company, Kirkland, Washington, 2008, 4-page brochure.
 “T270 Class 6 and T370 Class 7 Hybrid,” Kenworth Truck Company, Kirkland, Washington, 2009, 6-page brochure.
 “T270 Class 6 and T370 Class 7,” Kenworth Truck Company, Kirkland, Washington, 2008, 6-page brochure.
 “T270 Class 6 and T370 Class 7,” Kenworth Truck Company, Kirkland, Washington, 2009, 6-page brochure.
 “T300,” Kenworth Truck Company, Kirkland, Washington, 1994, 4-page brochure.
 “T300,” Kenworth Truck Company, Kirkland, Washington, 1997, 5-page brochure.
 “T300,” Kenworth Truck Company, Kirkland, Washington, 2001, 16-page brochure.
 “T300,” Kenworth Truck Company, Kirkland, Washington, 2005, 16-page brochure.
 “T400B and T450B,” Kenworth Truck Company, Kirkland, Washington, 1992, 10-page brochure.
 “T440,” Kenworth Truck Company, Kirkland, Washington, 2010, 2-page brochure.
 “T440,” Kenworth Truck Company, Kirkland, Washington, 2010, 6-page brochure.
 “T470,” Kenworth Truck Company, Kirkland, Washington, 2010, 6-page brochure.
 T470H, Kenworth Truck Company, Kirkland, Washington, 2009, 2-page brochure.
 “T600,” Kenworth Truck Company, Kirkland, Washington, 1996, 7-page brochure.
 “T600,” Kenworth Truck Company, Kirkland, Washington, 2002, 28-page brochure.
 “T600,” Kenworth Truck Company, Kirkland, Washington, 2005, 24-page brochure.
 “T600, Ten Years of Innovation,” Kenworth Truck Company, Kirkland, Washington, 1995, 6-page brochure.
 “T600A,” Kenworth Truck Company, Kirkland, Washington, 1985, 10-page brochure.
 “T660,” Kenworth Truck Company, Kirkland, Washington, 2007, 36-page brochure.
 T660, Kenworth Truck Company, Kirkland, Washington, 2009, 36-page brochure.
 “T700,” Kenworth Truck Company, Kirkland, Washington, 2010, 6-page brochure.
 “T800,” Kenworth Truck Company, Kirkland, Washington, 1996, 7-page brochure.
 “T800,” Kenworth Truck Company, Kirkland, Washington, 2002, 32-page brochure.
 “T800,” Kenworth Truck Company, Kirkland, Washington, 2003, 32-page brochure.
 “T800,” Kenworth Truck Company, Kirkland, Washington, 2005, 28-page brochure.
 “T800,” Kenworth Truck Company, Kirkland, Washington, 2009, 28-page brochure.

(56)

References Cited

OTHER PUBLICATIONS

T800B, Kenworth Truck Company, Kirkland, Washington, 1993, 8-page brochure.

"The World's Best," Kenworth Truck Company, Kirkland, Washington, 1992, 12-page brochure.

"W900," Kenworth Truck Company, Kirkland, Washington, 1996, 7-page brochure.

"W900," Kenworth Truck Company, Kirkland, Washington, 2002, 32-page brochure.

"W900," Kenworth Truck Company, Kirkland, Washington, 2005, 28-page brochure.

"W900L Aero Cab," Kenworth Truck Company, Kirkland, Washington, 1994, 2-page brochure.

* cited by examiner

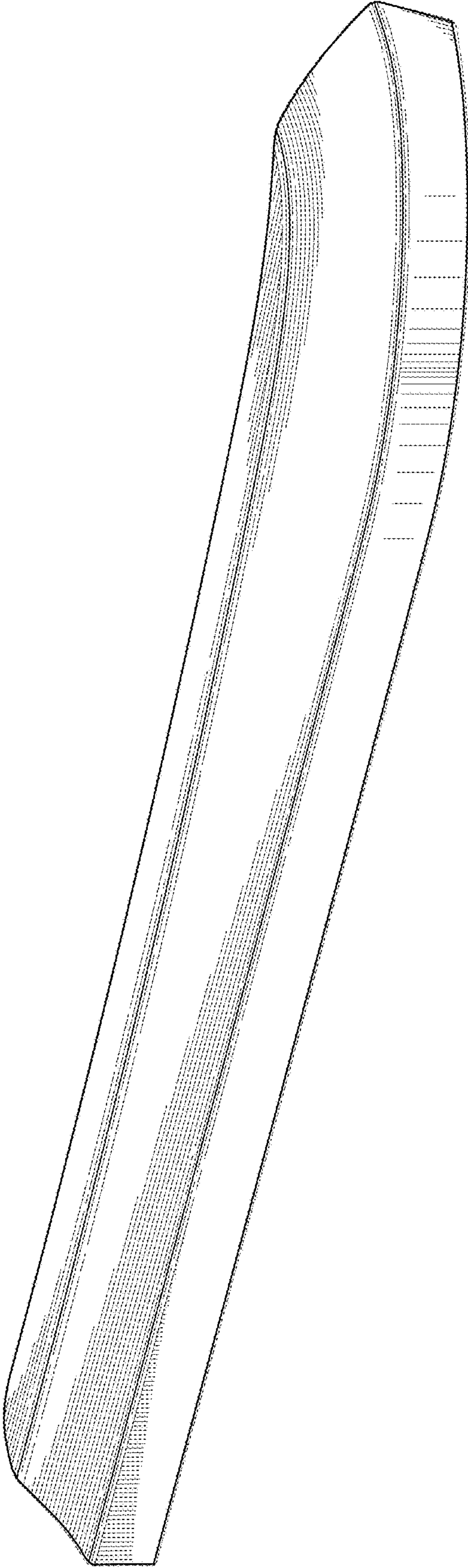

Fig. 1.

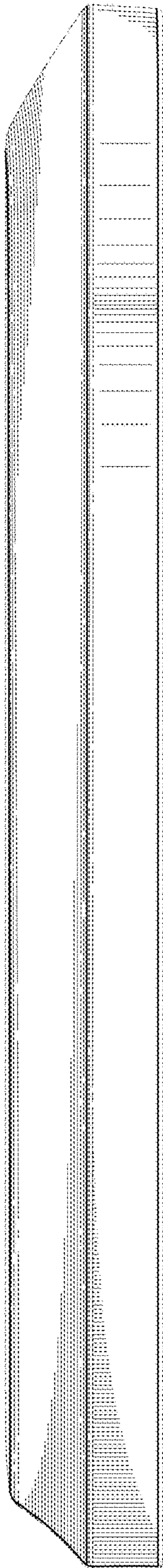

Fig. 2.

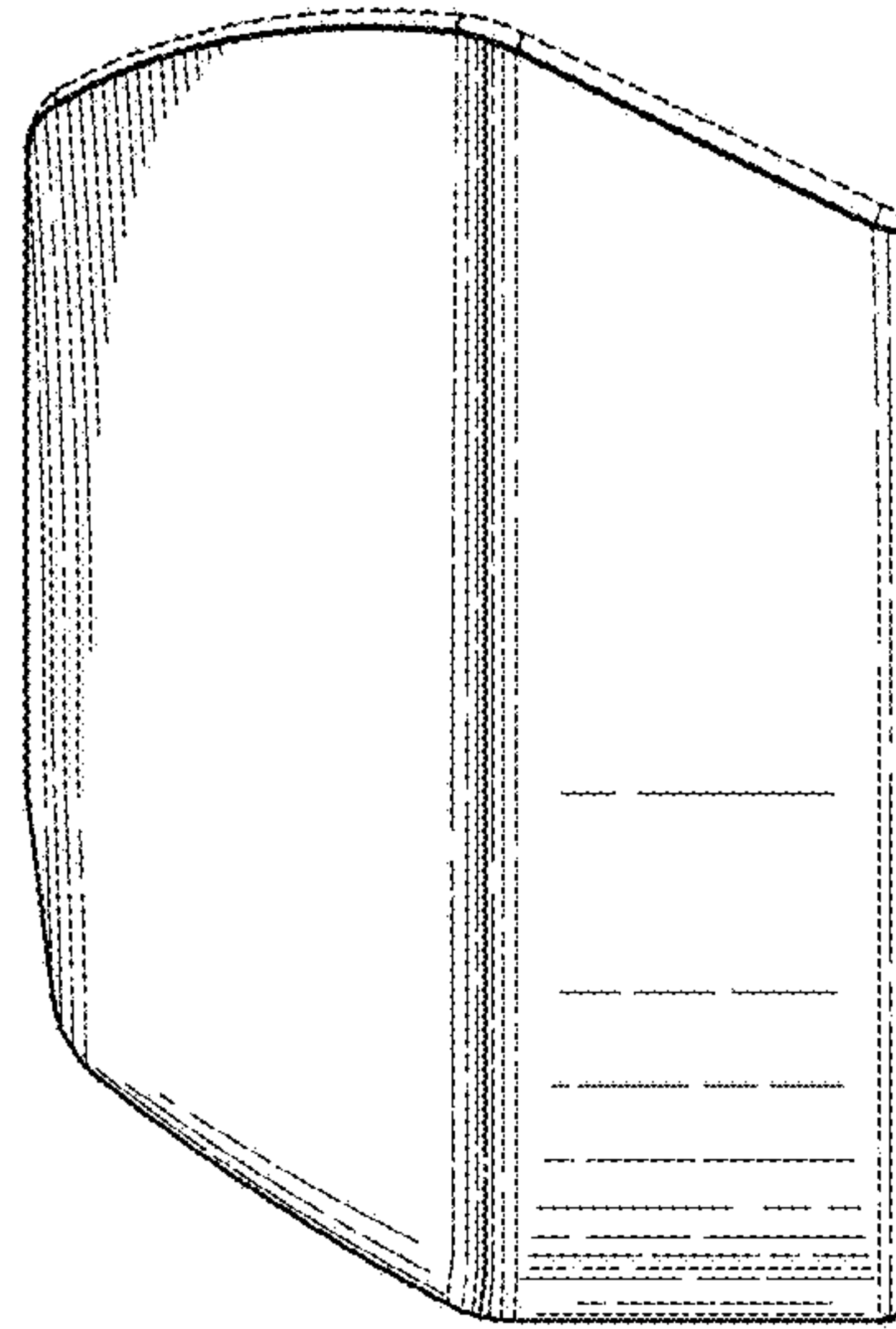

Fig. 4.

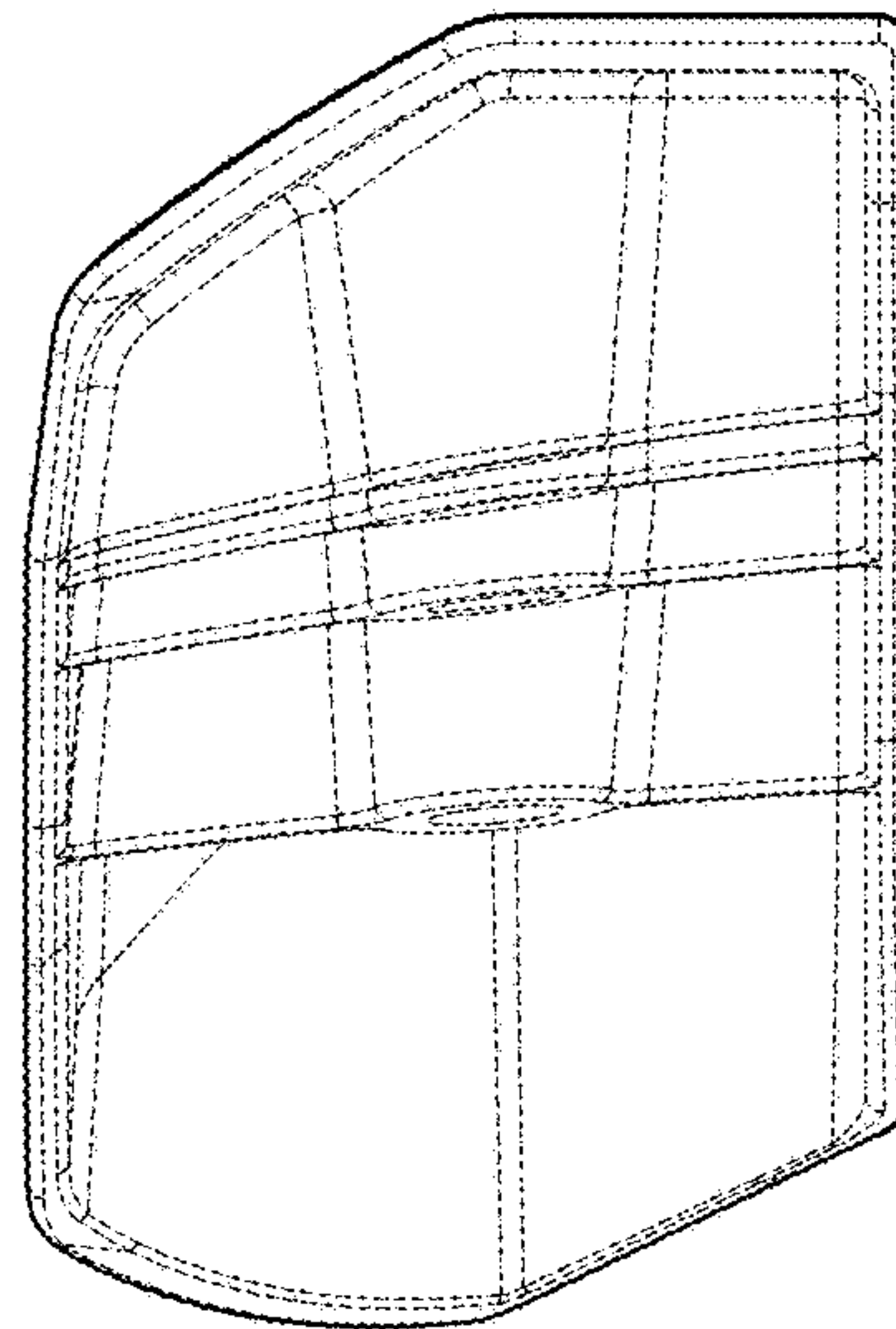

Fig. 3.

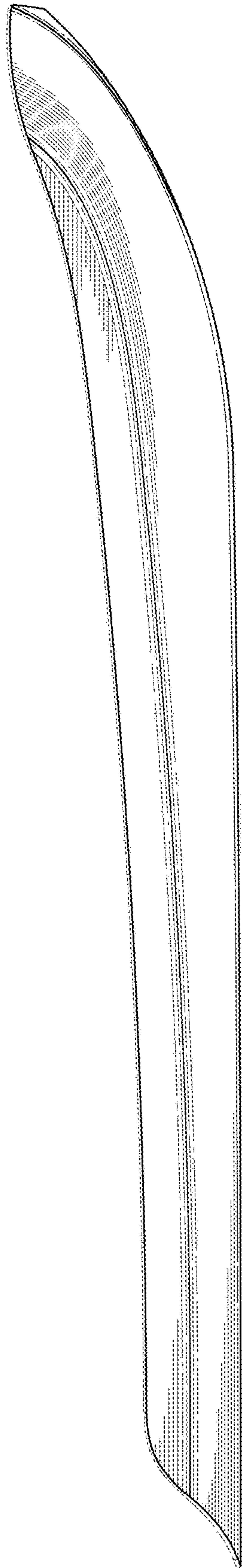

Fig. 5.

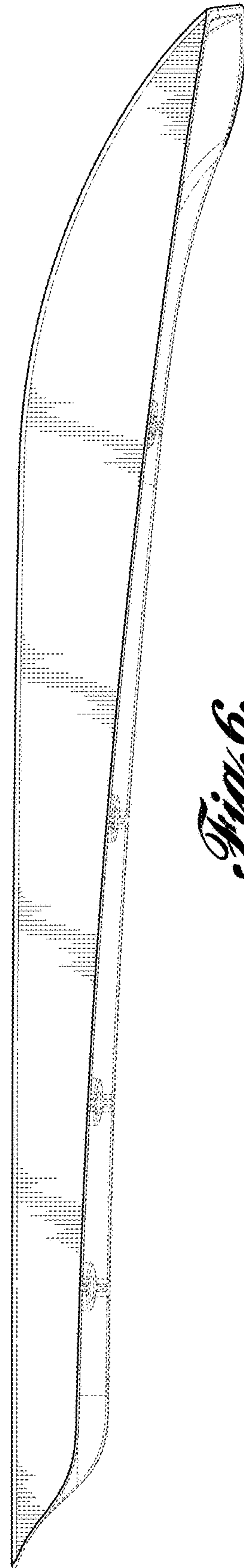

Fig. 6.

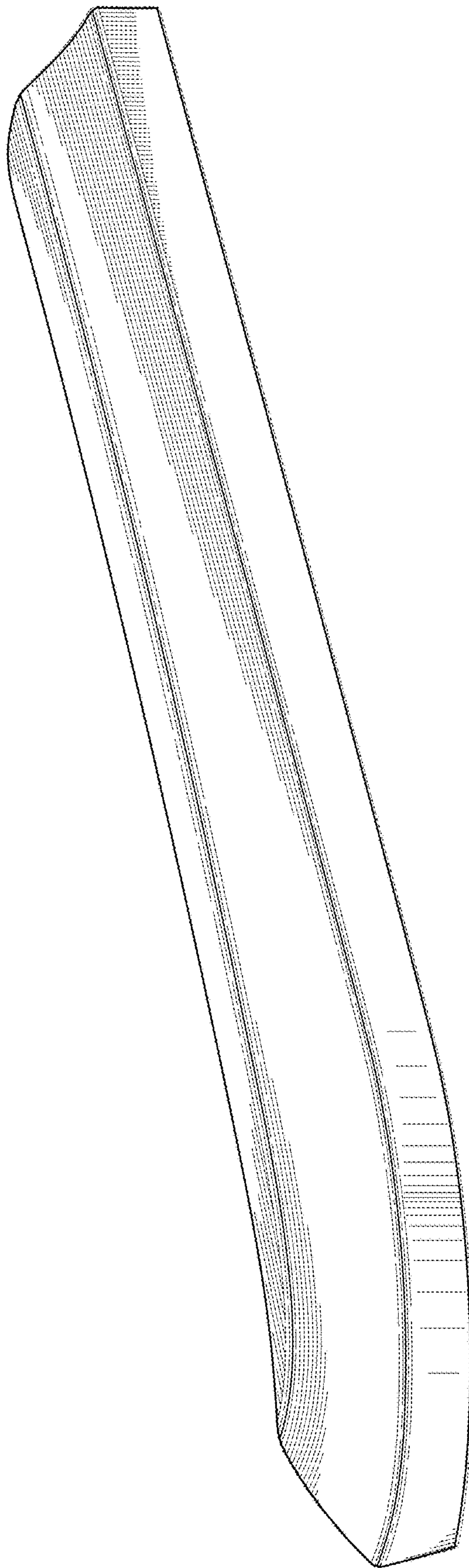

Fig. 7.

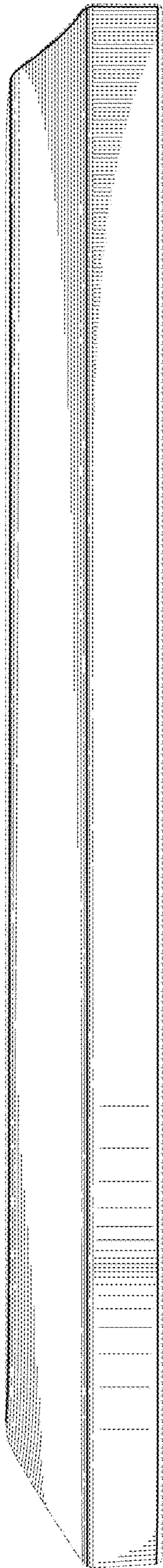

Fig. 8.

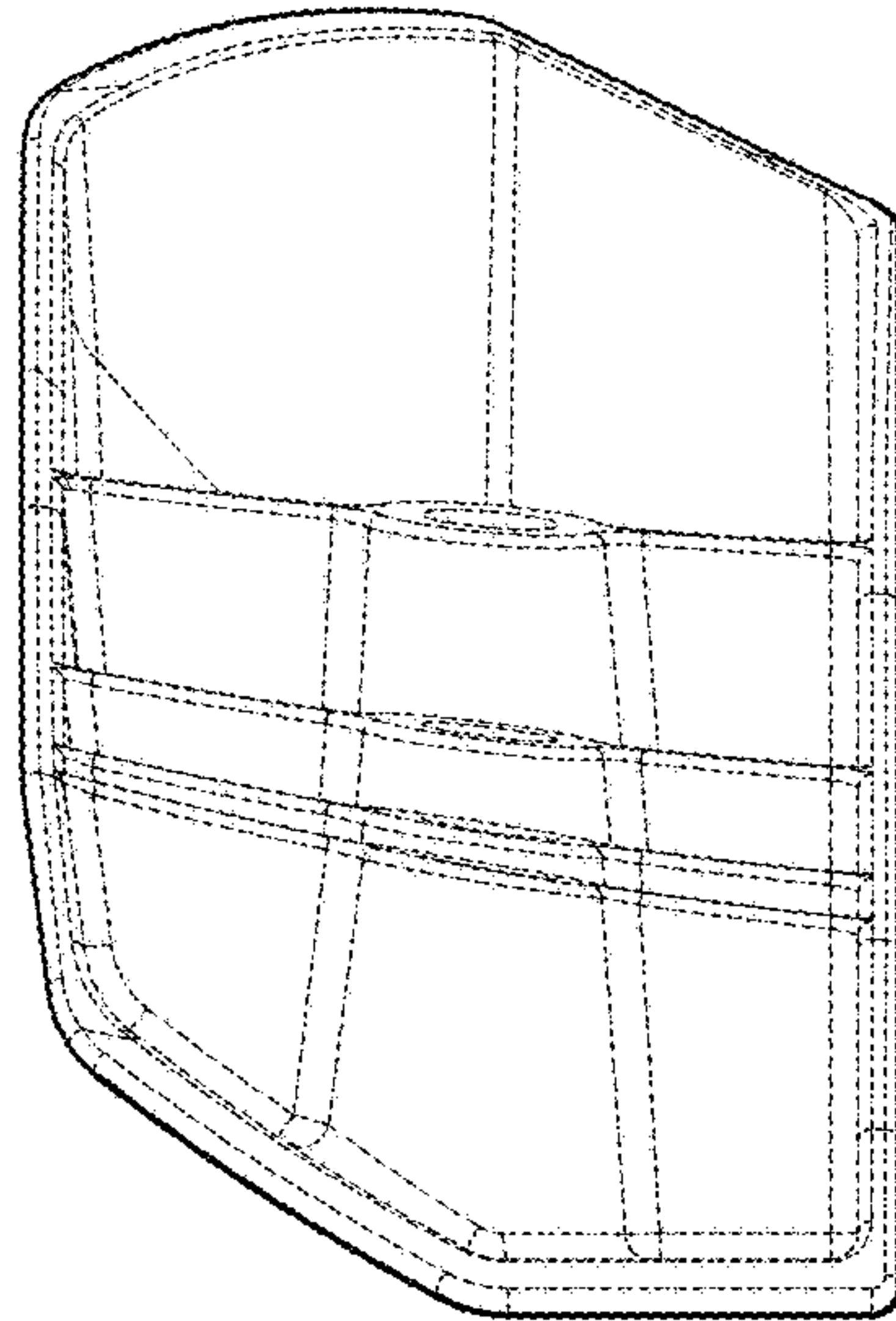

Fig. 10.

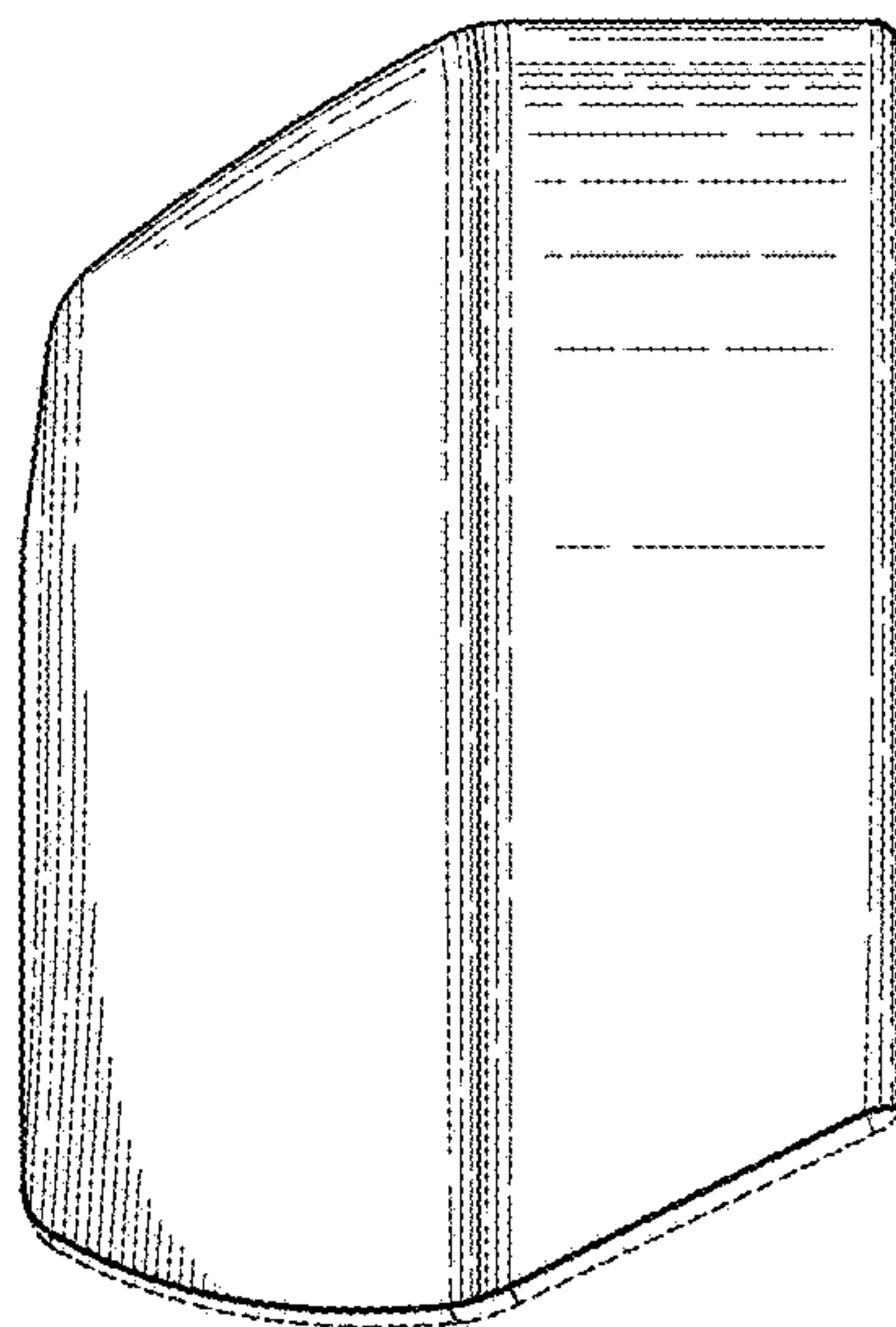

Fig. 9.

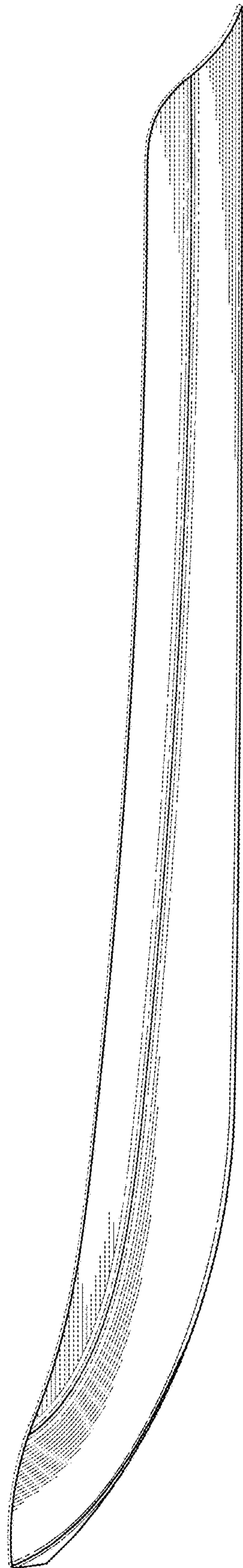

Fig. 11.

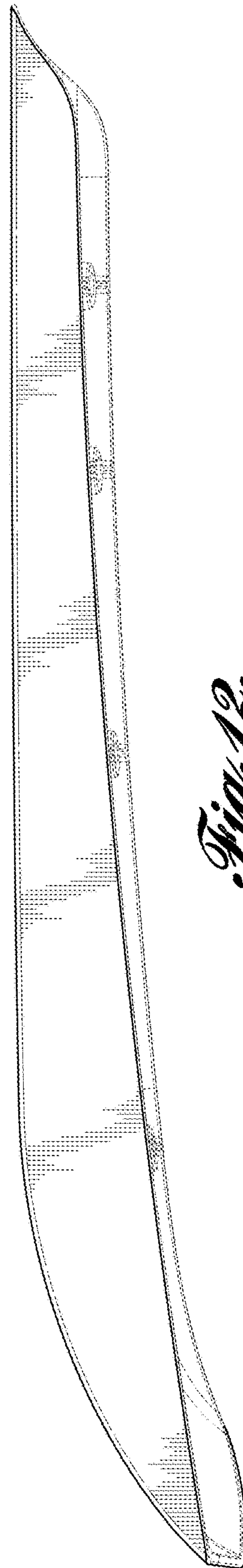

Fig. 12.