



US00D817489S

(12) **United States Design Patent** (10) **Patent No.:** **US D817,489 S**  
**Nelson et al.** (45) **Date of Patent:** **\*\* May 8, 2018**

(54) **ANGLE DRILL GUIDE**

(71) Applicant: **DePuy Synthes Products, Inc.**,  
Raynham, MA (US)

(72) Inventors: **Adam Nelson**, West Chester, PA (US);  
**Steven Greco**, West Chester, PA (US);  
**Dominic D'Andrea**, Wallingford, PA  
(US)

(73) Assignee: **DePuy Synthes Products, Inc.**,  
Raynham, MA (US)

(\*\*) Term: **15 Years**

(21) Appl. No.: **29/584,081**

(22) Filed: **Nov. 11, 2016**

(51) **LOC (11) Cl.** ..... **24-02**

(52) **U.S. Cl.**  
USPC ..... **D24/140**

(58) **Field of Classification Search**  
USPC ..... D24/140, 144, 146, 133, 135, 136  
CPC ..... A61B 17/1622; A61B 17/1664; A61B  
17/1671; A61B 17/1673; A61B 17/1675;  
A61B 17/1677; A61B 17/17; A61B  
17/1742; A61B 17/1746; A61B 17/175;  
A61B 17/1753; A61B 17/1757; A61B  
17/176; A61B 17/1764; A61B 17/1767;  
A61B 17/80

See application file for complete search history.

(56) **References Cited**

**U.S. PATENT DOCUMENTS**

D291,246 S *	8/1987	Lower	.....	D24/140
D382,959 S *	8/1997	Arpe	.....	D24/133
D398,996 S *	9/1998	Simmons	.....	D24/146
D404,126 S *	1/1999	Asfora	.....	D24/140
D420,132 S *	2/2000	Bucholz	.....	D24/140
D492,995 S *	7/2004	Rue	.....	D24/113
D574,495 S *	8/2008	Petersen	.....	D24/140
D669,984 S *	10/2012	Cheney	.....	D24/140
D708,324 S *	7/2014	Schwarz	.....	D24/133

D747,479 S *	1/2016	Knight	.....	D24/140
D747,803 S *	1/2016	Knight	.....	D24/140
D791,944 S *	7/2017	Palazzolo	.....	D24/140
2012/0253353 A1 *	10/2012	McBride	.....	A61B 17/1757 606/97

**FOREIGN PATENT DOCUMENTS**

WO	WO 2008064211 A1 *	5/2008	.....	A61B 17/1728
WO	WO 2015/100325 A1	7/2015		
WO	WO 2015105979 A1 *	7/2015	.....	A61B 17/1728
WO	WO 2017075060 A1 *	5/2017	.....	A61B 17/15

**OTHER PUBLICATIONS**

medGadget. <URL: <https://www.medgadget.com/2014/04/new-anspach-eg1-high-speed-electric-surgical-drill-from-depuy-synthes.html>> Apr. 8, 2014. DePuy Synthes High Speed Electric Surgical Drill.\*

\* cited by examiner

*Primary Examiner* — Bridget L Eland

*Assistant Examiner* — Lauren McVey

(74) *Attorney, Agent, or Firm* — Wayne C. Jaeschke, Jr.

(57) **CLAIM**

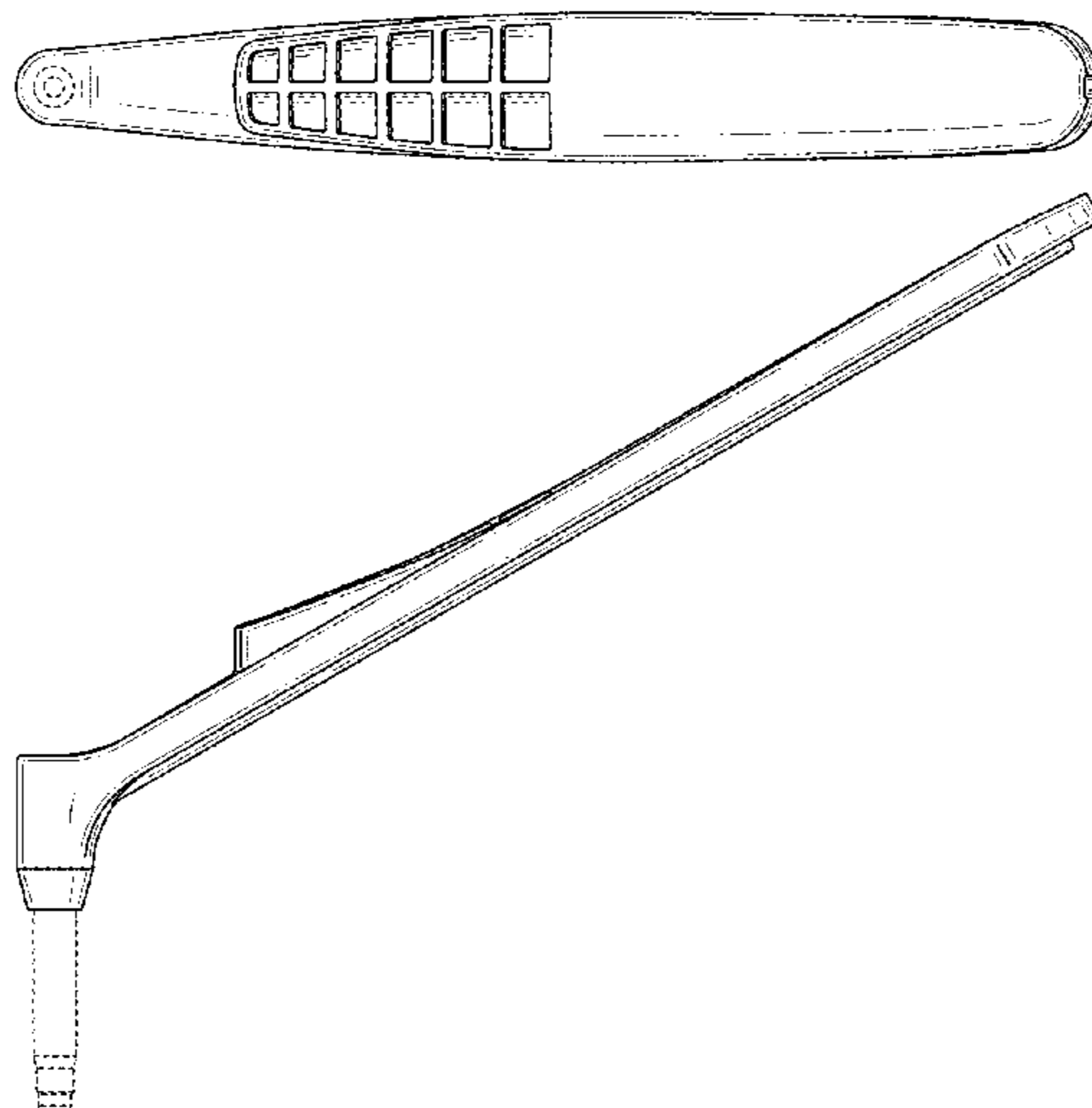
We claim the ornamental design for a angle drill guide, as shown and described.

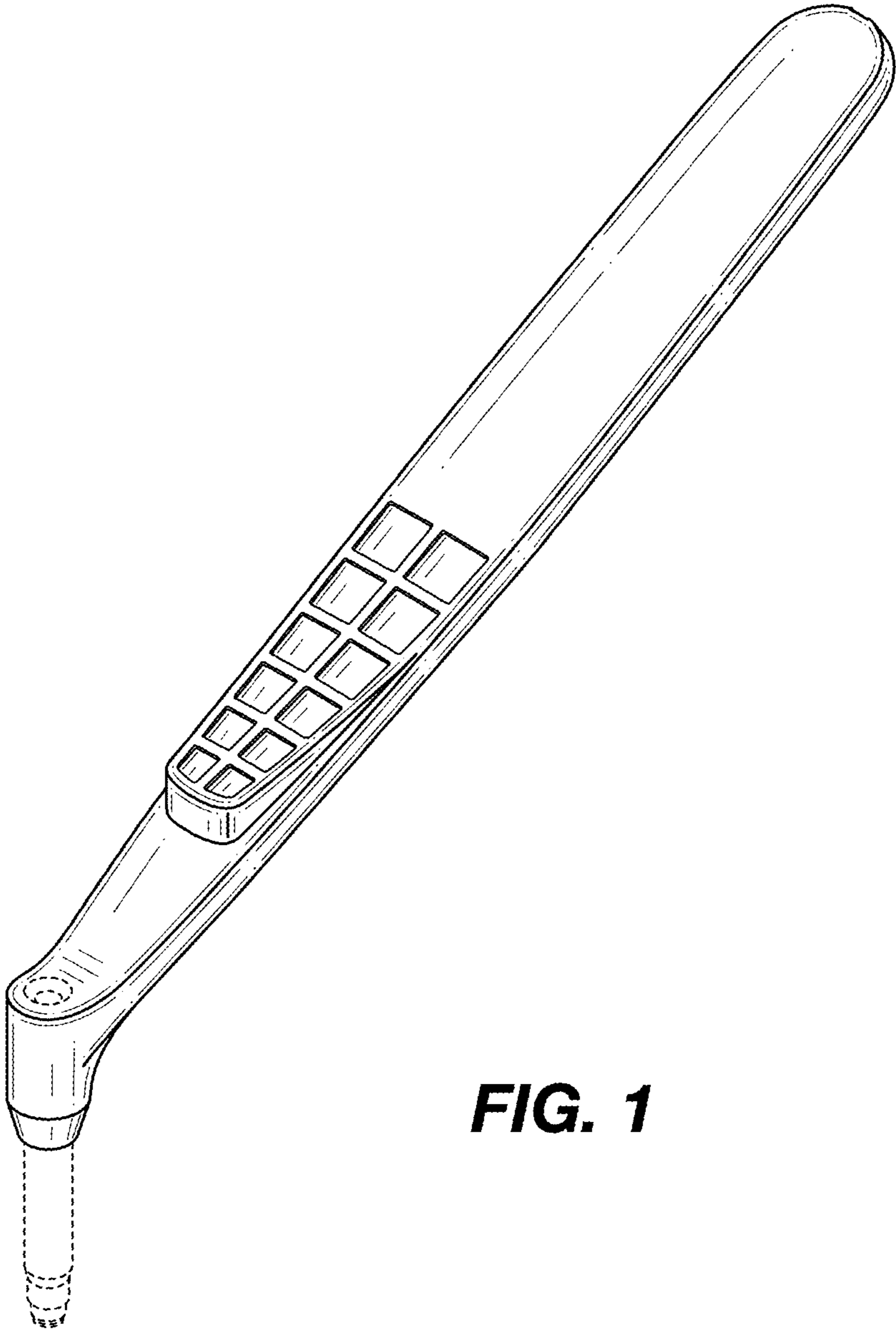
**DESCRIPTION**

FIG. 1 is a top perspective view of an angle drill guide, showing our new design;  
FIG. 2 is a top plan view thereof;  
FIG. 3 is a side elevation view thereof;  
FIG. 4 is a bottom plan view thereof;  
FIG. 5 is a front elevation view thereof; and,  
FIG. 6 is a rear elevation view thereof.

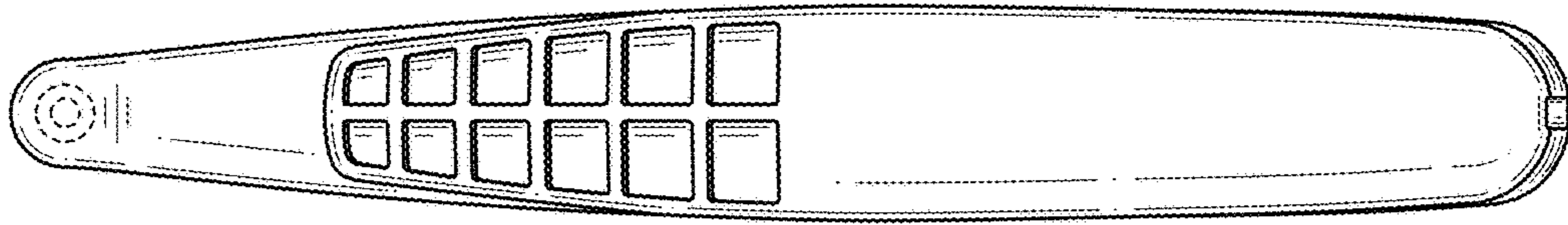
The broken lines immediately adjacent the claim represent the bounds of the claimed design while all other broken lines are directed to environment and are for illustrative purposes only; the broken lines form no part of the claimed design.

**1 Claim, 3 Drawing Sheets**

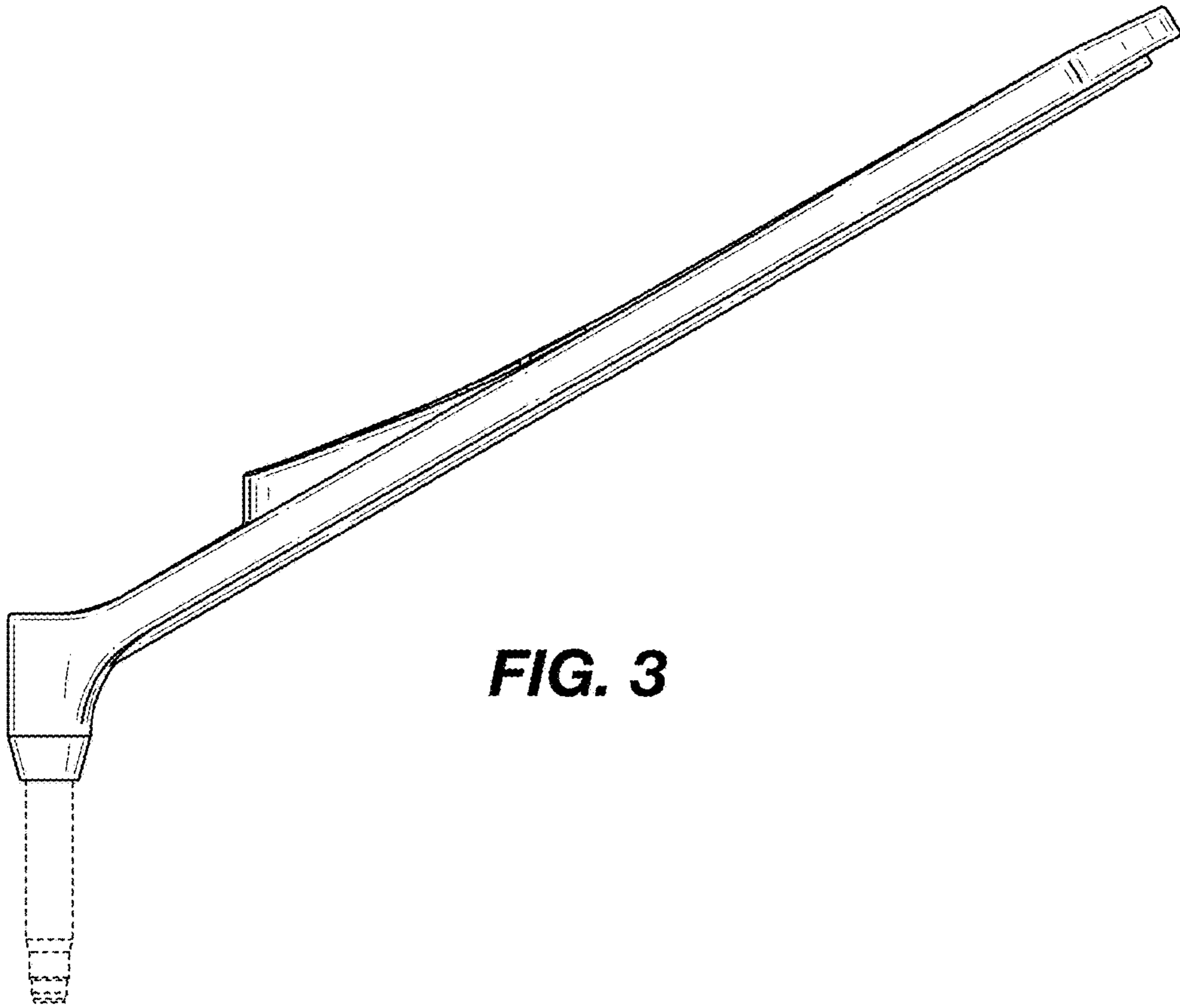




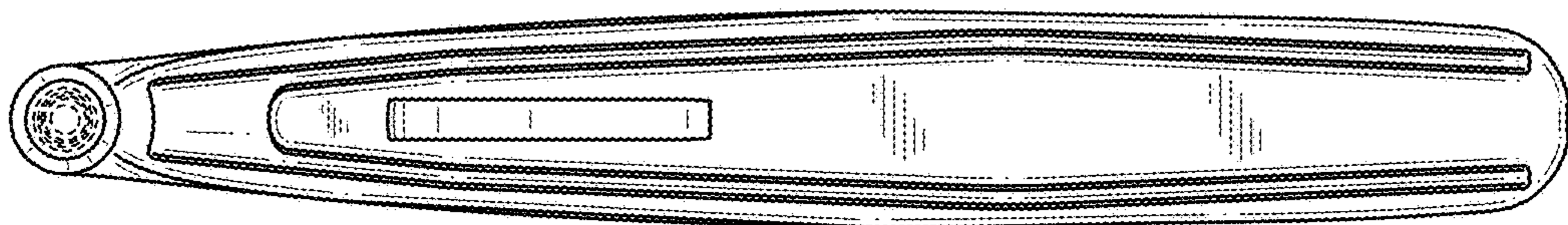
**FIG. 1**



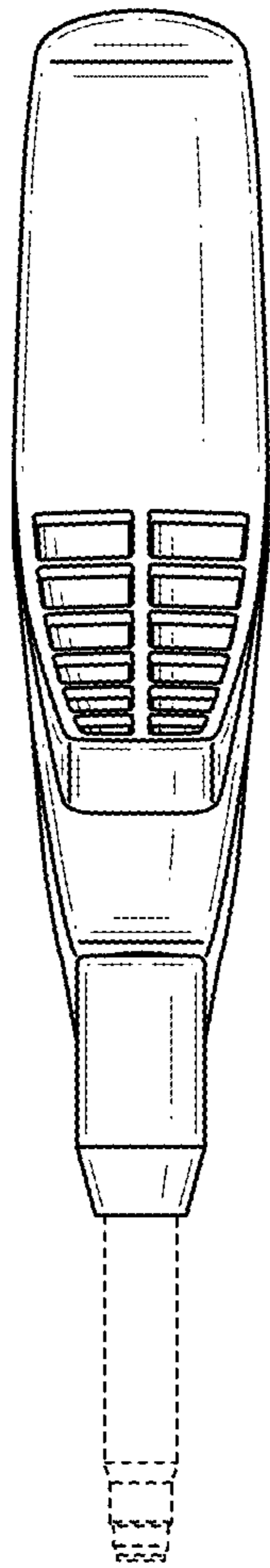
**FIG. 2**



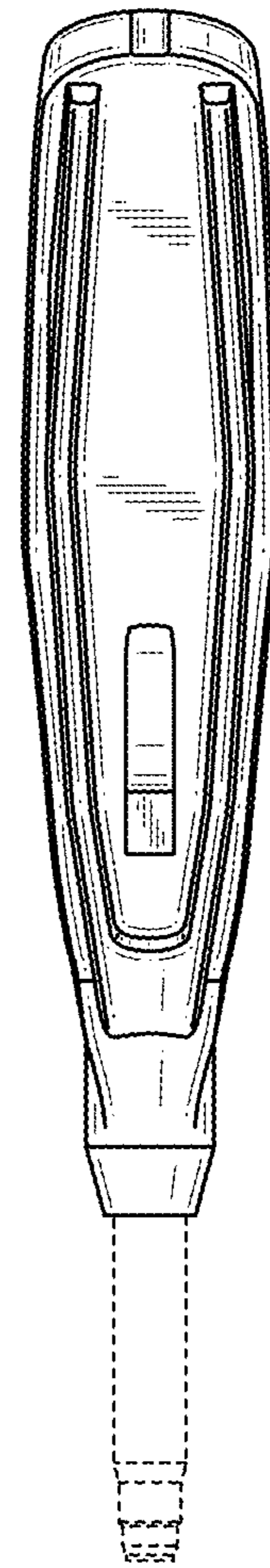
**FIG. 3**



**FIG. 4**



**FIG. 5**



**FIG. 6**