



US00D817440S

(12) **United States Design Patent**
Lossie et al.

(10) **Patent No.:** **US D817,440 S**
(45) **Date of Patent:** **** May 8, 2018**

- (54) **OIL FILTER HOUSING**
- (71) Applicant: **General Electric Company,**
Schenectady, NY (US)
- (72) Inventors: **Jared James Lossie,** Erie, PA (US);
Paul John Fontecchio, Erie, PA (US)
- (73) Assignee: **General Electric Company,**
Schenectady, NY (US)
- (**) Term: **15 Years**
- (21) Appl. No.: **29/574,762**
- (22) Filed: **Aug. 18, 2016**
- (51) **LOC (11) Cl.** **23-07**
- (52) **U.S. Cl.**
USPC **D23/209**
- (58) **Field of Classification Search**
USPC D23/207, 209; 123/196 A, 196 R
CPC F16N 39/005; F01M 11/03; C02F 1/003;
B01D 35/30
See application file for complete search history.

- D591,825 S * 5/2009 Quintel D23/209
- D719,635 S * 12/2014 Reed D23/209
- D757,212 S 5/2016 Fontecchio et al.
- 9,333,448 B2 * 5/2016 Braunheim B01D 35/153
- 2014/0291230 A1 10/2014 Fontecchio
- 2016/0160715 A1 6/2016 Fontecchio et al.

* cited by examiner

Primary Examiner — Robin V Webster
(74) *Attorney, Agent, or Firm* — GE Global Patent
Operation; John A. Kramer

(57) **CLAIM**

The ornamental design for an oil filter housing, as shown and described.

DESCRIPTION

FIG. 1 is a top right perspective view of a design for an oil filter housing according to the present disclosure.
 FIG. 2 is a front view of the oil filter housing of FIG. 1.
 FIG. 3 is a back view of the oil filter housing of FIG. 1.
 FIG. 4 is a left side view of the oil filter housing of FIG. 1.
 FIG. 5 is a right side view of the oil filter housing of FIG. 1.
 FIG. 6 is a top view of the oil filter housing of FIG. 1; and,
 FIG. 7 is a bottom view of the oil filter housing of FIG. 1.
 The solid lines in FIGS. 1-7 illustrate an oil filter housing according to the present invention.
 The broken lines in FIGS. 1-7 are included for the purpose of illustrating environmental structure and form no part of the claimed design.

1 Claim, 6 Drawing Sheets

(56) **References Cited**

U.S. PATENT DOCUMENTS

- D113,679 S * 3/1939 Neely D15/150
- D129,867 S * 10/1941 Dunmire D15/150
- 3,762,467 A * 10/1973 Poon F01M 5/00
165/119
- D460,146 S * 7/2002 Setser D23/209

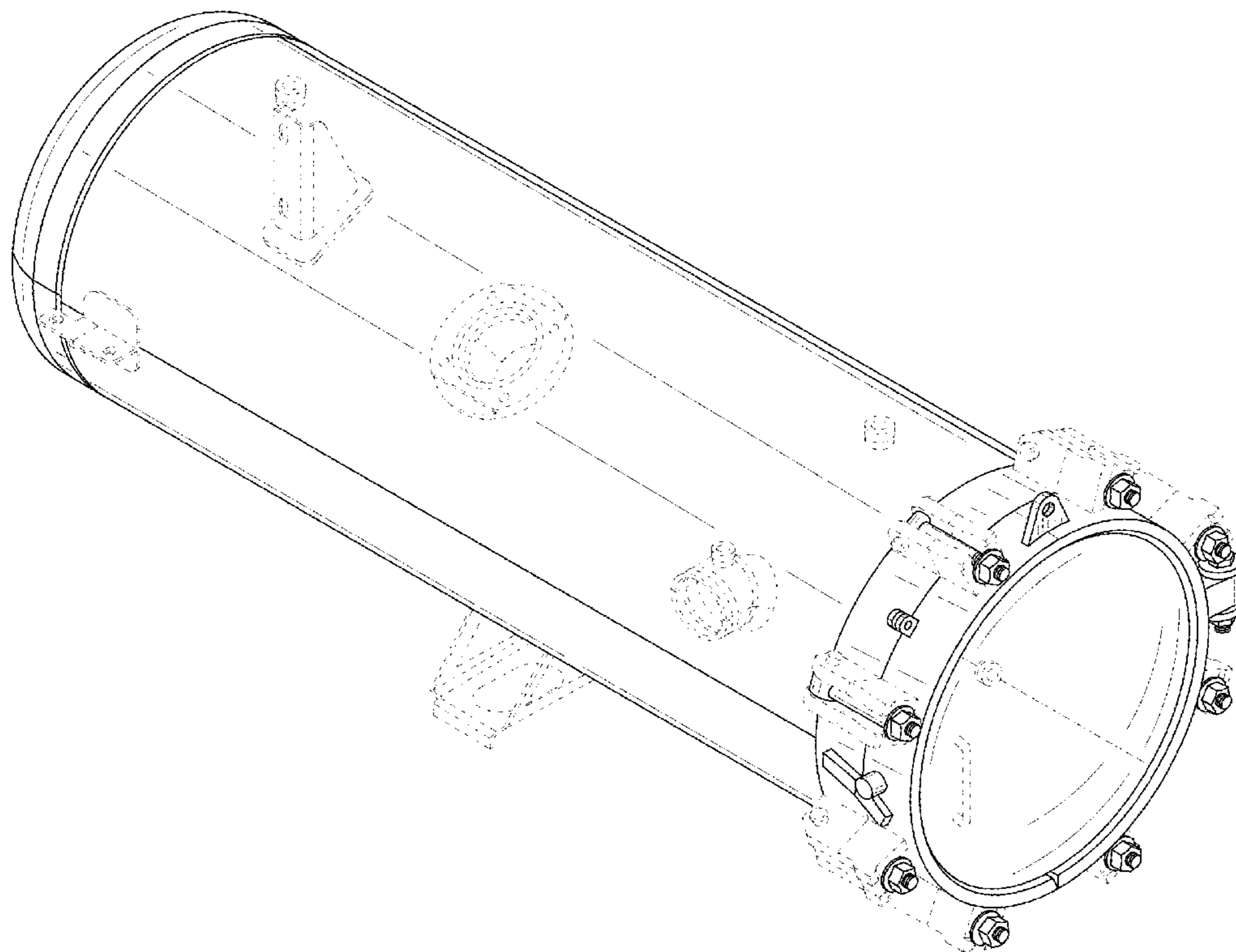

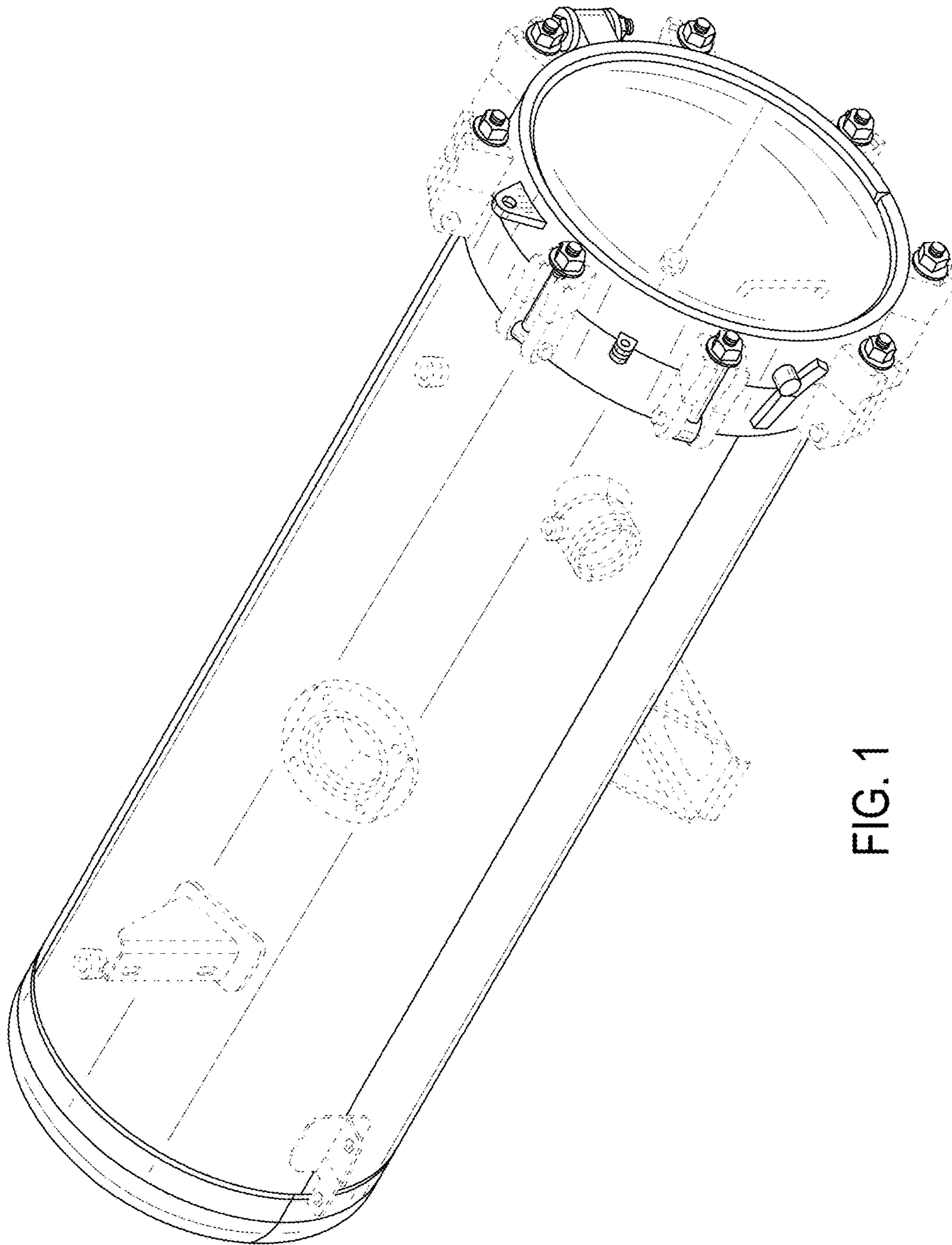

FIG. 1

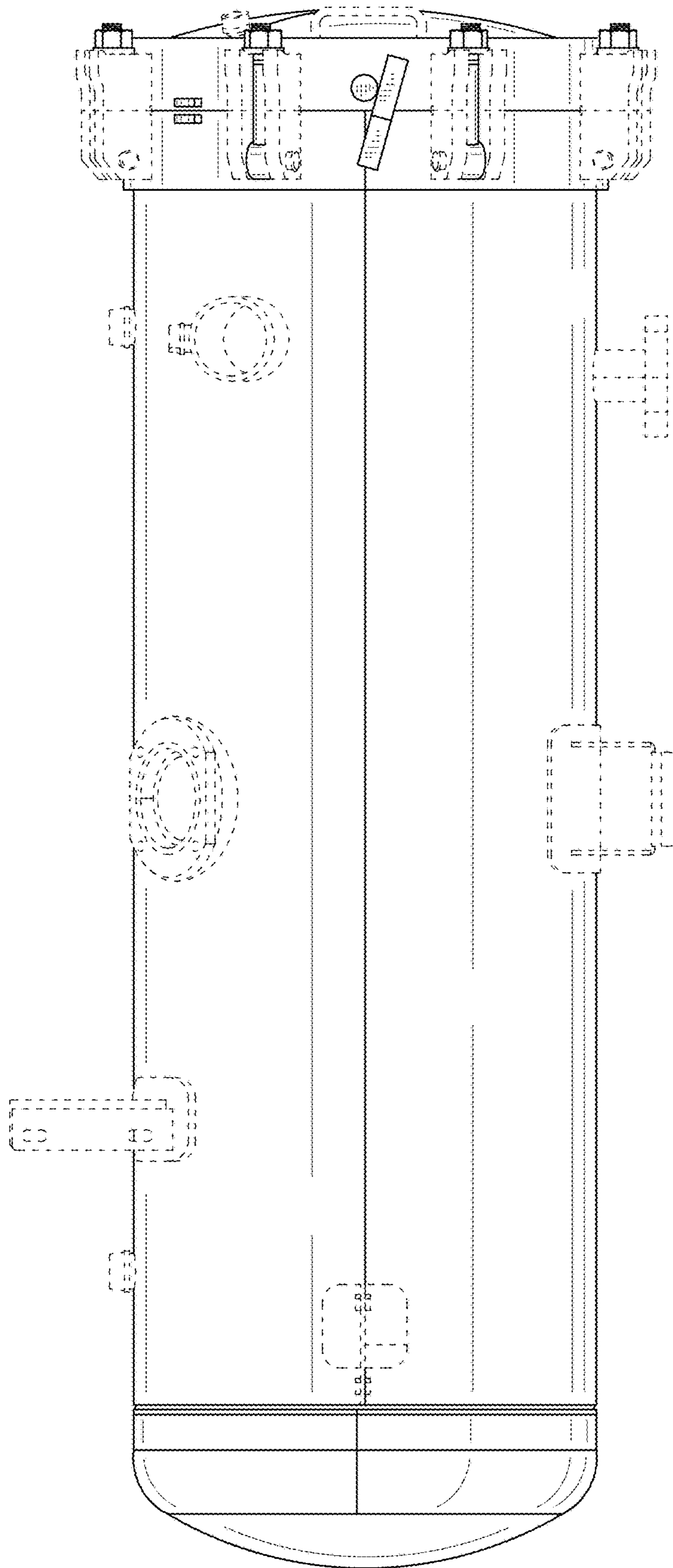

FIG. 2

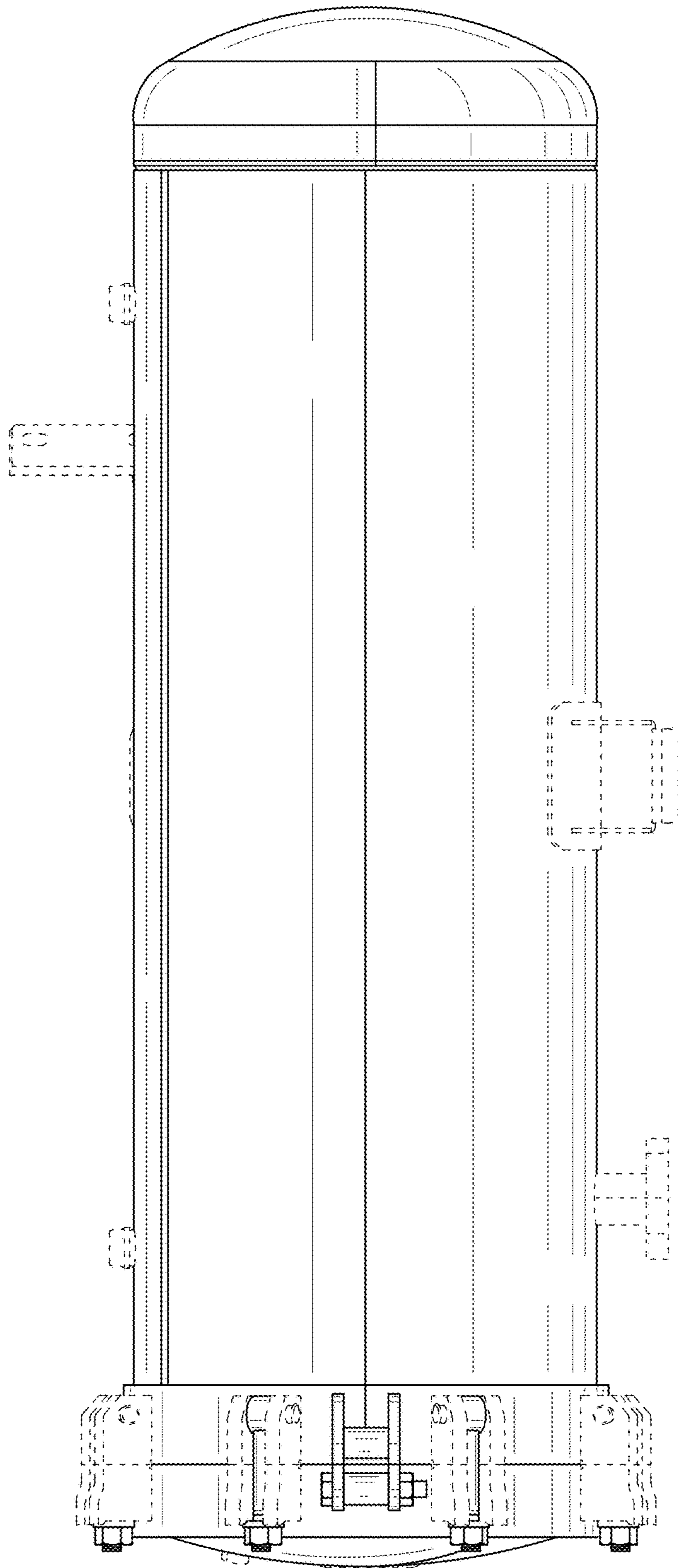

FIG. 3

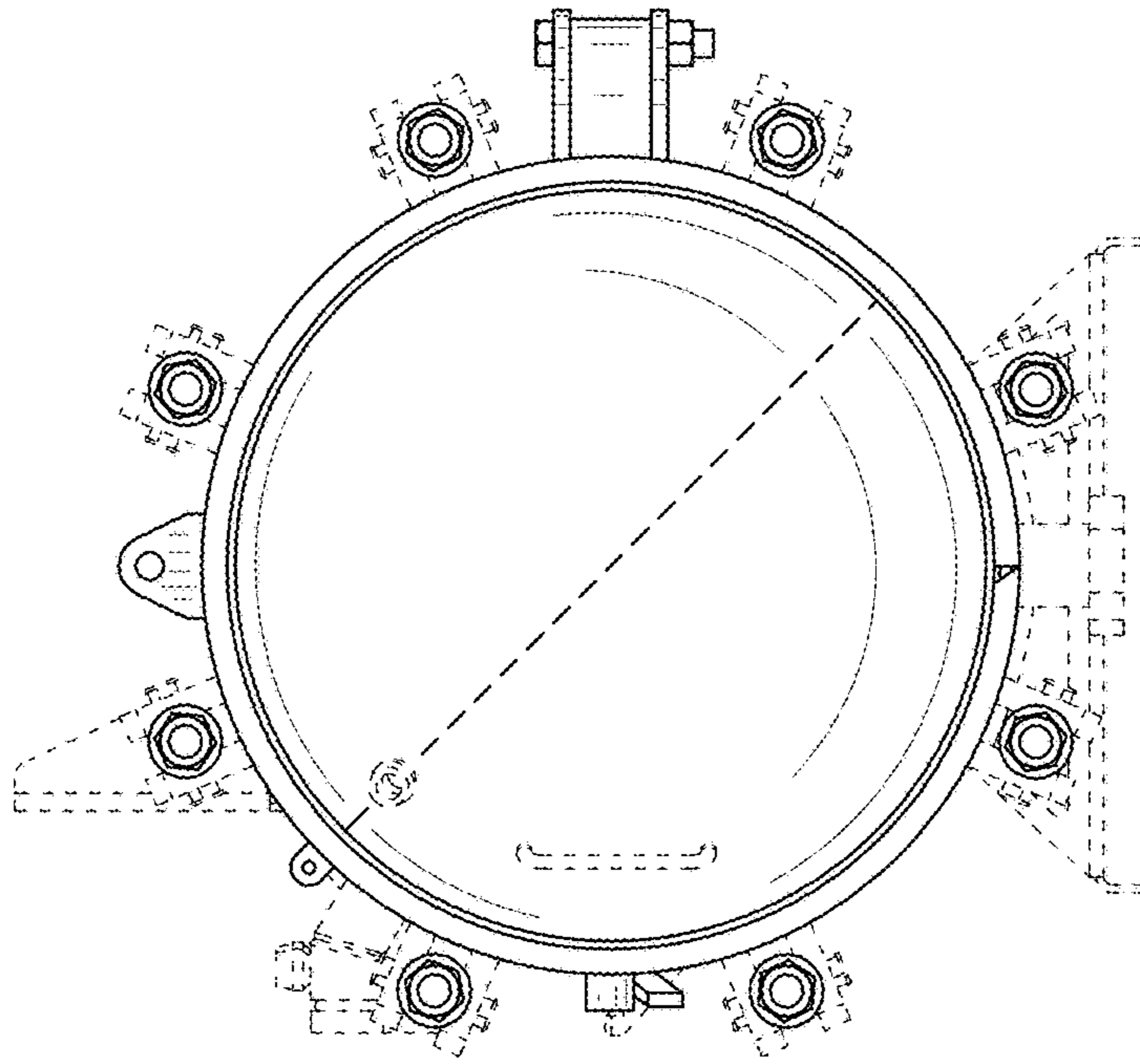

FIG. 5

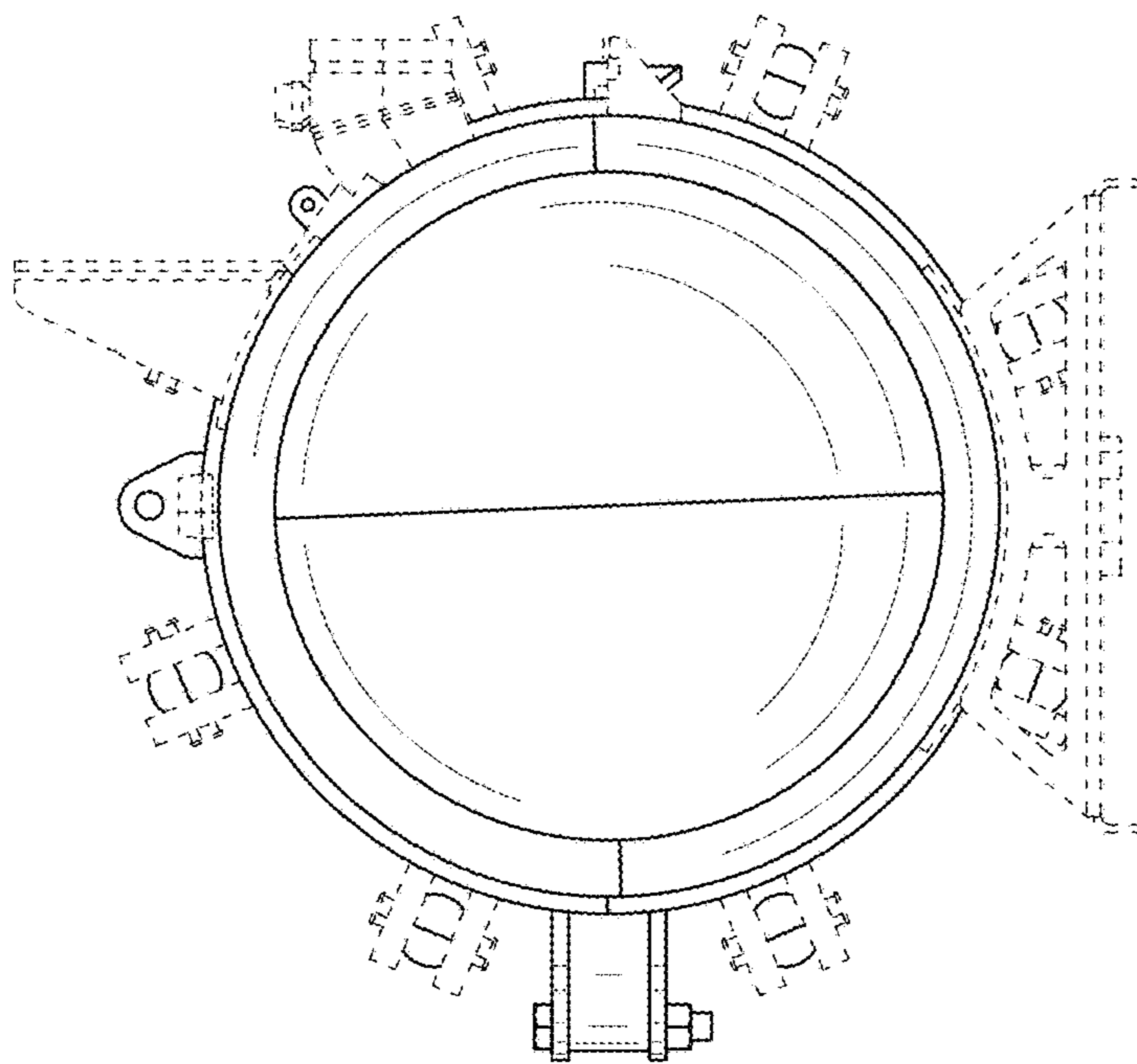

FIG. 4

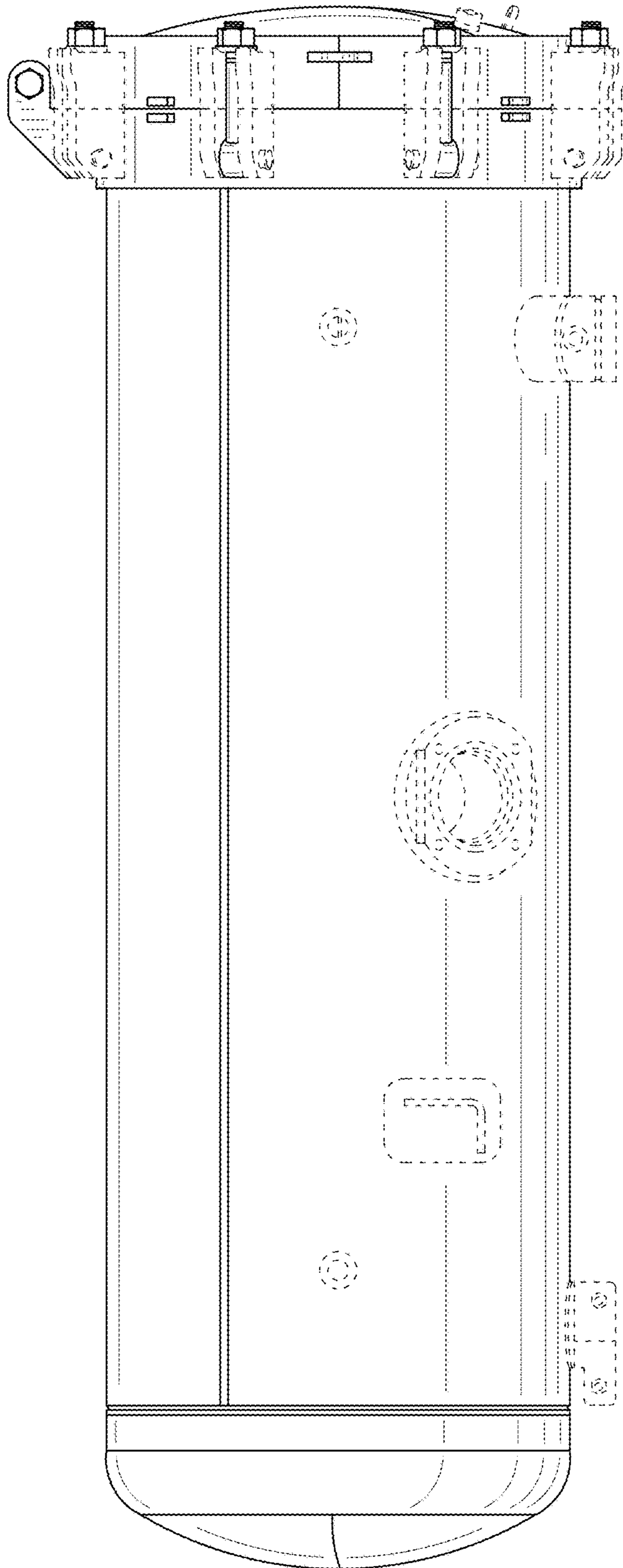

FIG. 6

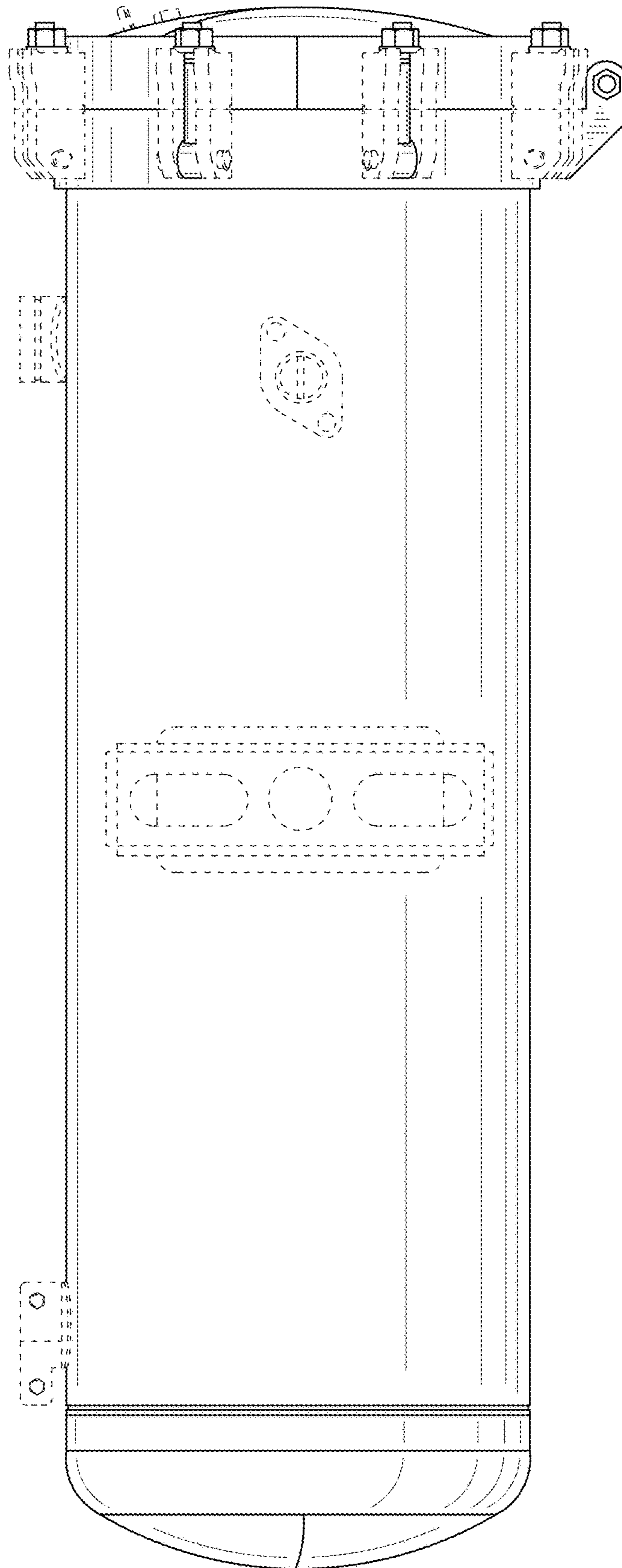

FIG. 7