



US00D817385S

(12) **United States Design Patent** (10) **Patent No.:** **US D817,385 S**  
**Shaw et al.** (45) **Date of Patent:** **\*\* May 8, 2018**

(54) **HUMBUCKING PICKUP**

FOREIGN PATENT DOCUMENTS

(71) Applicants: **Fender Musical Instruments Corporation**, Scottsdale, AZ (US);  
**E.L.V.H., Inc.**, Los Angeles, CA (US)

CA 2869073 A1 \* 4/2016 ..... G10H 3/181

(72) Inventors: **Timothy P. Shaw**, Hendersonville, TN (US); **Edward Lodewijk Van Halen**, Los Angeles, CA (US); **Matthew Jonathon Bruck**, Studio City, CA (US); **Joshua D. Hurst**, Nashville, TN (US)

OTHER PUBLICATIONS

Amazon, BQLZ Silver Smooth pickup, first available on Feb. 26, 2016, [online], [site visited on Jan. 19, 2018]. Available from Internet, < URL: [https://www.amazon.co.uk/BQLZR-Silver-Smooth-Aluminum-Electric/dp/B01C8FPA68/ref=sr\\_1\\_3?ie=UTF8&qid=1516388721&sr=8-3&keywords=pickup+with+no+holes](https://www.amazon.co.uk/BQLZR-Silver-Smooth-Aluminum-Electric/dp/B01C8FPA68/ref=sr_1_3?ie=UTF8&qid=1516388721&sr=8-3&keywords=pickup+with+no+holes)> (Year: 2016).\*

(73) Assignees: **Fender Musical Instruments Corporation**, Scottsdale, AZ (US);  
**E.L.V.H., Inc.**, Los Angeles, CA (US)

(Continued)

(\*\*) Term: **15 Years**

*Primary Examiner* — Sheryl Lane

*Assistant Examiner* — Samantha N Wood

(21) Appl. No.: **29/580,771**

(74) *Attorney, Agent, or Firm* — Robert D. Atkins; Patent Law Group: Atkins and Associates, P.C.

(22) Filed: **Oct. 12, 2016**

(51) **LOC (11) Cl.** ..... **17-03**

(52) **U.S. Cl.**

USPC ..... **D17/20**

(58) **Field of Classification Search**

USPC .... D17/4, 9, 13, 14, 15–21, 24, 99; D99/43, D99/99; D10/83, 94–95, 103, 121; D11/164, 184

CPC ..... G10D 13/00; G10D 13/02; G10D 13/06; G10D 13/08; G10D 13/12; G10D 13/14; G10D 13/143; G10D 13/146; G10D 1/00;

(Continued)

(56) **References Cited**

U.S. PATENT DOCUMENTS

2,119,584 A 6/1938 Knoblaugh  
2,896,491 A 7/1959 Lover  
2,911,871 A 11/1959 Schultz

(Continued)

(57) **CLAIM**

The ornamental design for a humbucking pickup, as shown and described.

**DESCRIPTION**

FIG. 1 is a perspective view of a first embodiment of a humbucking pickup;

FIG. 2 is a side view of the humbucking pickup of FIG. 1;

FIG. 3 is a front view of the humbucking pickup of FIG. 1;

FIG. 4 is a top view of the humbucking pickup of FIG. 1;

FIG. 5 is a bottom view of the humbucking pickup of FIG. 1;

FIG. 6 is a perspective view of a second embodiment of the humbucking pickup;

FIG. 7 is a side view of the humbucking pickup of FIG. 2;

FIG. 8 is a front view of the humbucking pickup of FIG. 2;

FIG. 9 is a top view of the humbucking pickup of FIG. 2;

and,

FIG. 10 is a bottom view of the humbucking pickup of FIG. 2.

**1 Claim, 4 Drawing Sheets**

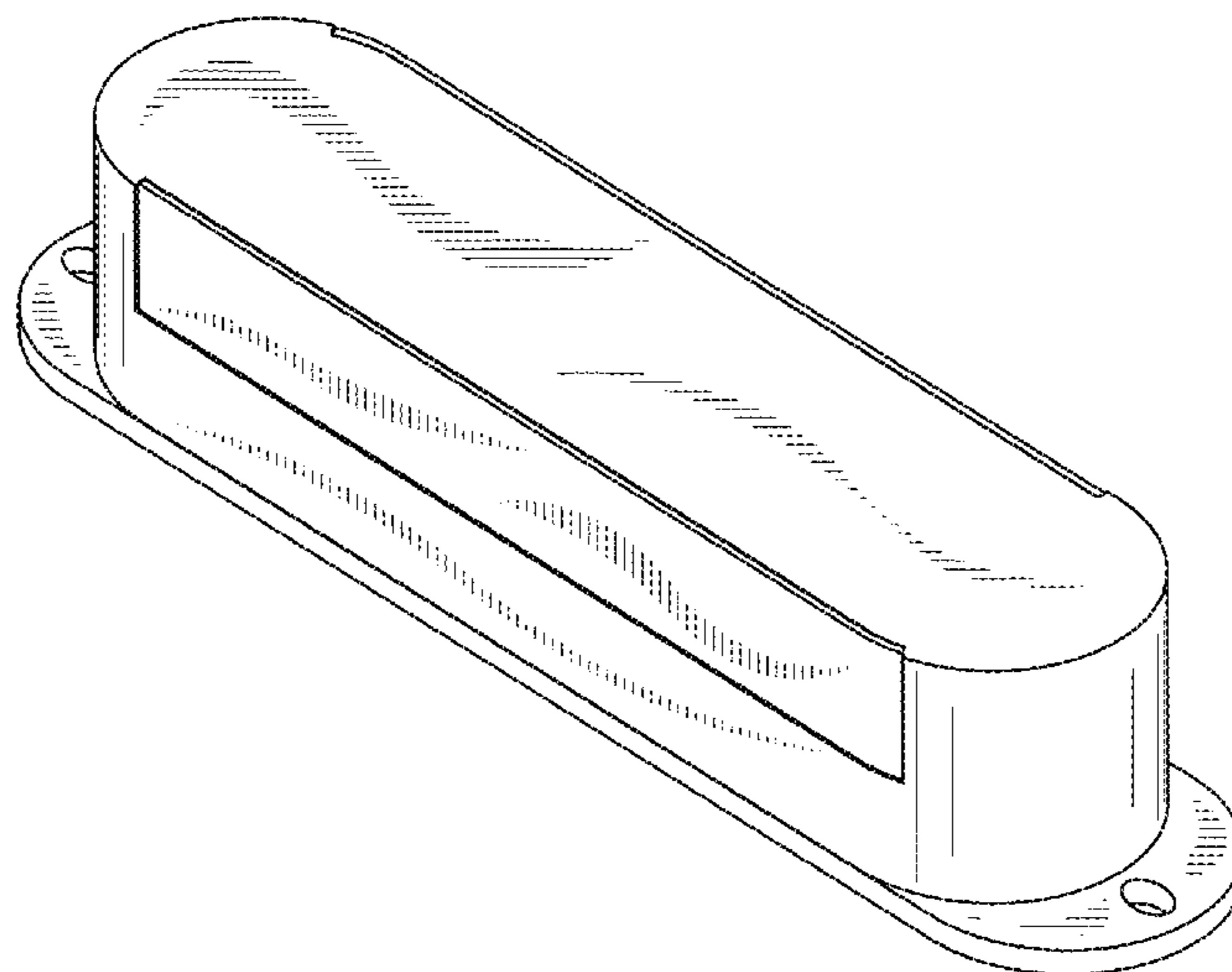

(58) **Field of Classification Search**  
 CPC ..... G10D 1/06; G10D 1/08; G10D 1/085;  
 G10H 3/00; G10H 3/18; G10H 3/181  
 See application file for complete search history.

(56) **References Cited**

U.S. PATENT DOCUMENTS

3,236,930 A \* 2/1966 Fender ..... G10H 3/181  
 84/728  
 3,657,461 A 4/1972 Freeman  
 3,902,394 A 9/1975 Stich  
 3,916,751 A 11/1975 Stich  
 4,026,178 A 5/1977 Fuller  
 4,069,732 A 1/1978 Moskowitz et al.  
 4,133,243 A 1/1979 DiMarzio  
 4,184,398 A 1/1980 Siegelman  
 4,220,069 A 9/1980 Fender  
 4,379,421 A \* 4/1983 Nunan ..... G10H 3/18  
 84/728  
 4,442,749 A 4/1984 DiMarzio et al.  
 4,450,748 A 5/1984 Shaw et al.  
 4,524,667 A 6/1985 Duncan  
 4,657,114 A 4/1987 Shaw  
 4,809,578 A 3/1989 Lace, Jr.  
 4,854,210 A 8/1989 Palazzolo  
 D323,669 S \* 2/1992 Pagelli ..... D17/14  
 5,148,733 A 9/1992 Beller  
 5,168,117 A 12/1992 Anderson  
 5,200,569 A \* 4/1993 Moore ..... G10H 3/18  
 84/723  
 5,288,119 A 2/1994 Crawford, Jr. et al.  
 5,290,968 A 3/1994 Mirigliano et al.  
 5,292,998 A 3/1994 Knapp  
 5,336,845 A 8/1994 Lace, Sr.  
 5,378,850 A 1/1995 Tumura  
 D355,207 S \* 2/1995 Beller ..... D17/20  
 5,389,731 A 2/1995 Lace  
 5,391,831 A \* 2/1995 Lace ..... G10H 3/181  
 84/726  
 5,391,832 A \* 2/1995 Lace ..... G10H 3/181  
 84/726  
 5,408,043 A 4/1995 Lace  
 5,422,432 A 6/1995 Lace  
 5,455,381 A 10/1995 Juskiewicz et al.  
 5,464,948 A 11/1995 Lace  
 5,508,474 A 4/1996 Tumura  
 5,525,750 A 6/1996 Beller  
 5,530,199 A 6/1996 Blucher  
 5,610,357 A 3/1997 Frank-Braun  
 5,789,691 A 8/1998 Stich  
 5,811,710 A 9/1998 Blucher et al.  
 5,834,999 A 11/1998 Kinman  
 5,908,998 A 6/1999 Blucher et al.  
 6,103,966 A 8/2000 Kinman  
 6,111,185 A 8/2000 Lace  
 6,271,456 B1 8/2001 Nelson

6,291,759 B1 9/2001 Turner  
 7,022,909 B2 4/2006 Kinman  
 D520,048 S \* 5/2006 Krozack ..... D17/20  
 7,166,793 B2 1/2007 Beller  
 7,227,076 B2 6/2007 Stich  
 7,285,714 B2 10/2007 Juskiewicz et al.  
 7,427,710 B2 9/2008 Hara  
 7,718,886 B1 5/2010 Lace  
 7,994,413 B2 8/2011 Salo  
 8,969,701 B1 3/2015 Dixon  
 9,601,100 B1 3/2017 Dixon  
 2002/0020281 A1 2/2002 Devers  
 2002/0083819 A1 7/2002 Kinman  
 2005/0109197 A1 5/2005 Garrett et al.  
 2005/0162247 A1 \* 7/2005 Beller ..... G10H 3/181  
 335/179  
 2007/0017355 A1 \* 1/2007 Lace ..... G10H 3/181  
 84/728  
 2010/0122623 A1 \* 5/2010 Salo ..... G10H 3/181  
 84/726  
 2012/0103170 A1 5/2012 Kinman  
 2013/0019736 A1 \* 1/2013 Finkle ..... G10D 3/00  
 84/313  
 2013/0312591 A1 11/2013 Mills  
 2013/0327202 A1 12/2013 Mills  
 2014/0202319 A1 7/2014 Osborne  
 2014/0245877 A1 \* 9/2014 Gelvin ..... G10H 3/181  
 84/727  
 2014/0373701 A1 12/2014 Yaron  
 2015/0262568 A1 9/2015 Krasnow  
 2015/0317966 A1 11/2015 Liptac  
 2015/0379978 A1 12/2015 Jang  
 2016/0314775 A1 10/2016 Wolf

OTHER PUBLICATIONS

Guitar Center, DiMarzio DP218 Super Distortion Strat Humbucker Pickup, customer review May 9, 2016, [online], [site visited on Jan. 19, 2018]. Available from Internet, <URL: <http://www.guitarcenter.com/DiMarzio/DP218-Super-Distortion-S-Strat-Humbucker-Pickup-White-1296839766977.gc>> (Year: 2016).\*

Guitar Center, Seymour Duncan STR-1 Vintage '54 Electric Guitar Pickup, customer review Nov. 9, 2010, [online], [site visited on Jan. 19, 2018]. Available from Internet, <URL: <http://www.guitarcenter.com/Seymour-Duncan/STR-1-Vintage-54-Tele-Rhythm-Electric-Guitar-Pickup.gc>> (Year: 2010).\*

Guitar Center, Lace Sensor Gold Guitar Pickups, customer review Jan. 19, 2007, [online], [site visited on Jan. 26, 2018]. Available from Internet, <URL: <http://www.guitarcenter.com/Lace/Sensor-Gold-Guitar-Pickups-3-Pack-S-S-S-Set.gc>> (Year: 2007).\*

Mike & Mike's Guitar Bar, Demystifying the Fender Jazzmaster and Jaguar pt. 4: Pickup Lines, posted Jul. 23, 2013, [online], [site visited Jan. 26, 2018]. Available from Internet, <URL: <https://mmguitarbar.com/2013/07/23/demystifying-the-fender-jazzmaster-and-jaguar-pt-4-pickup-lines/>> (Year: 2013).\*

\* cited by examiner

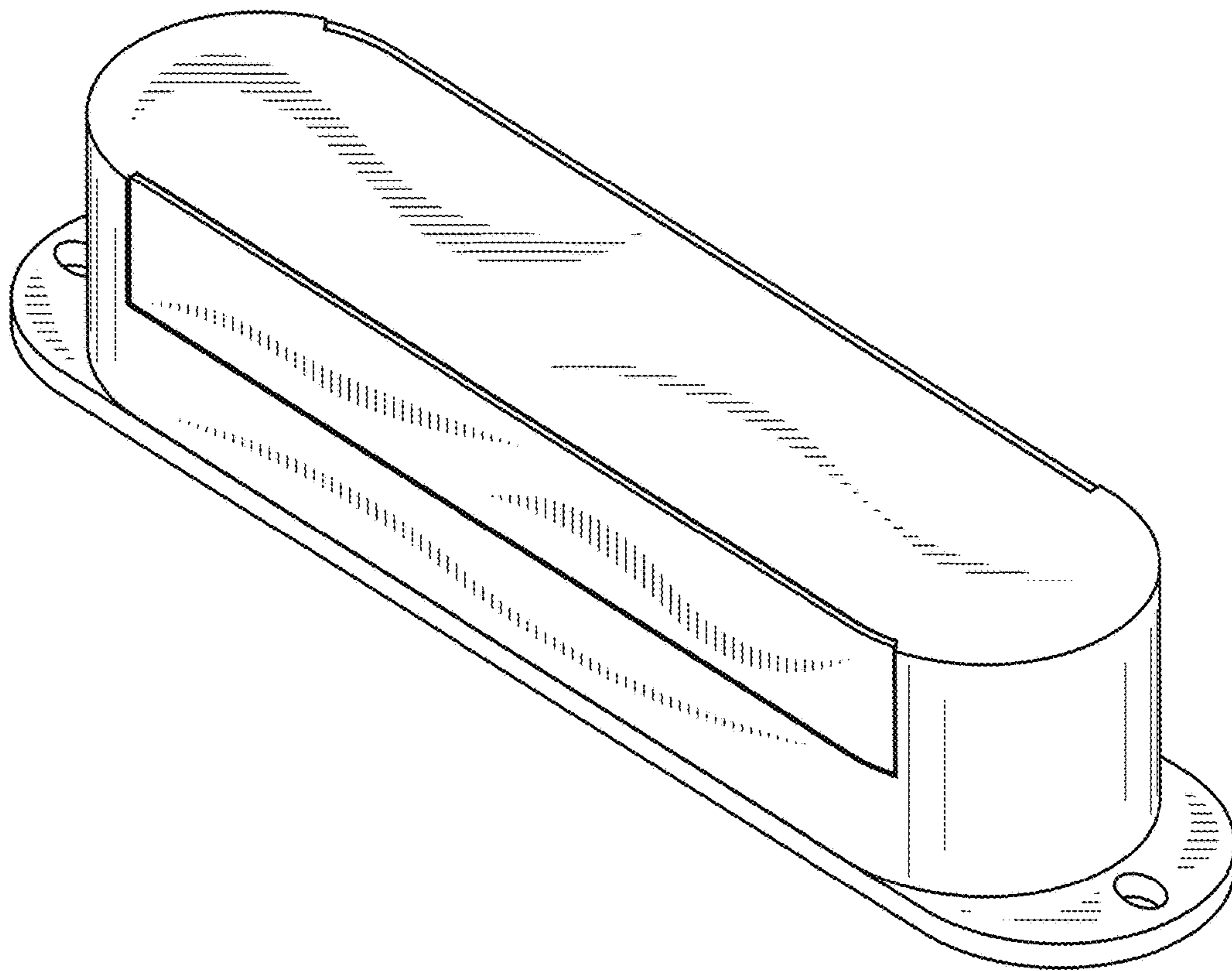

*FIG. 1*

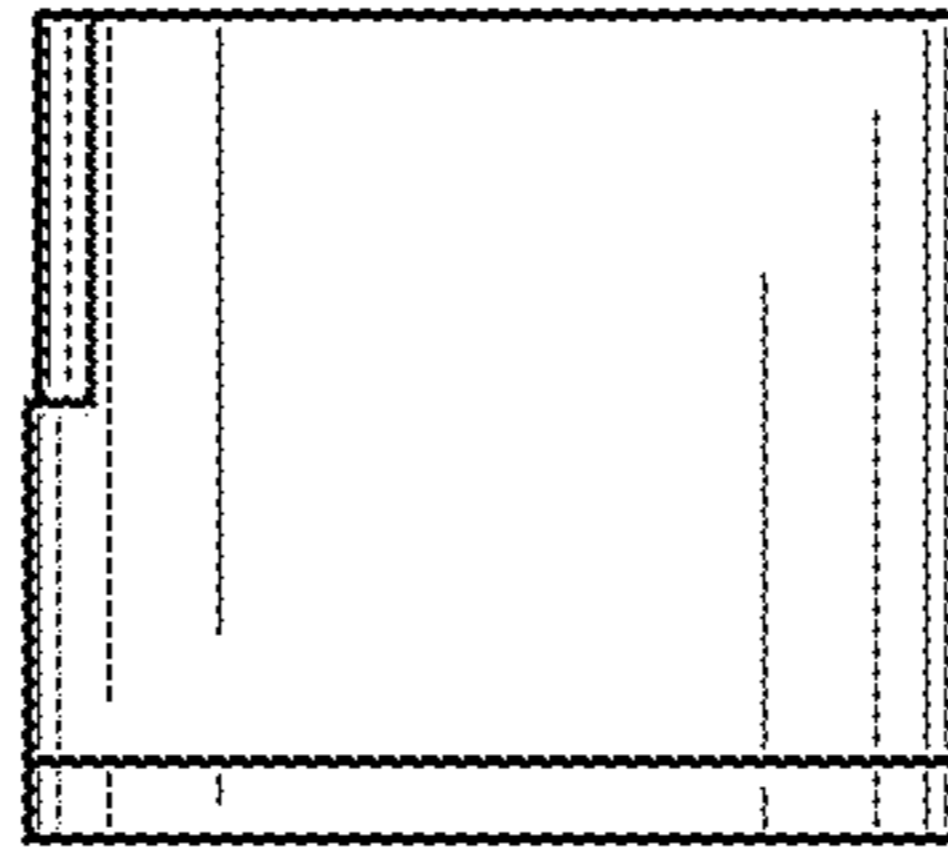

FIG. 2

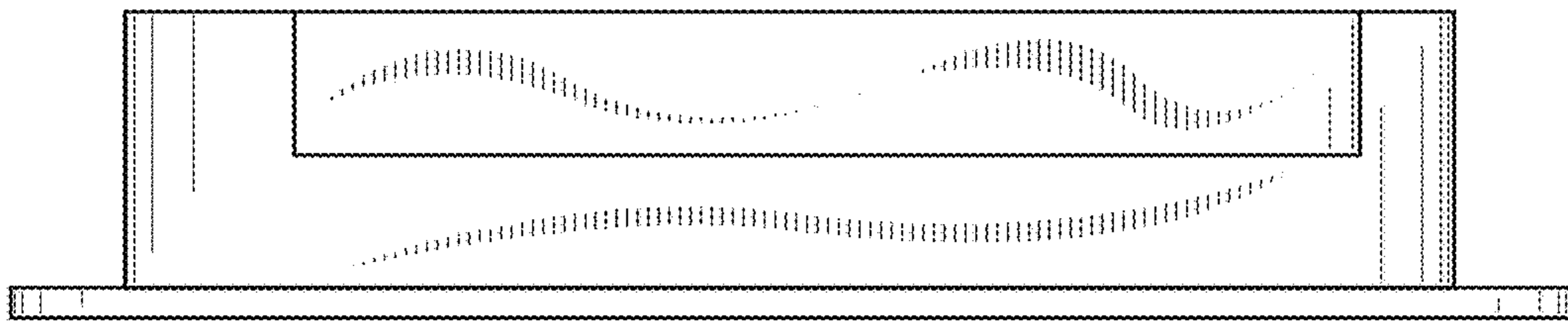

FIG. 3

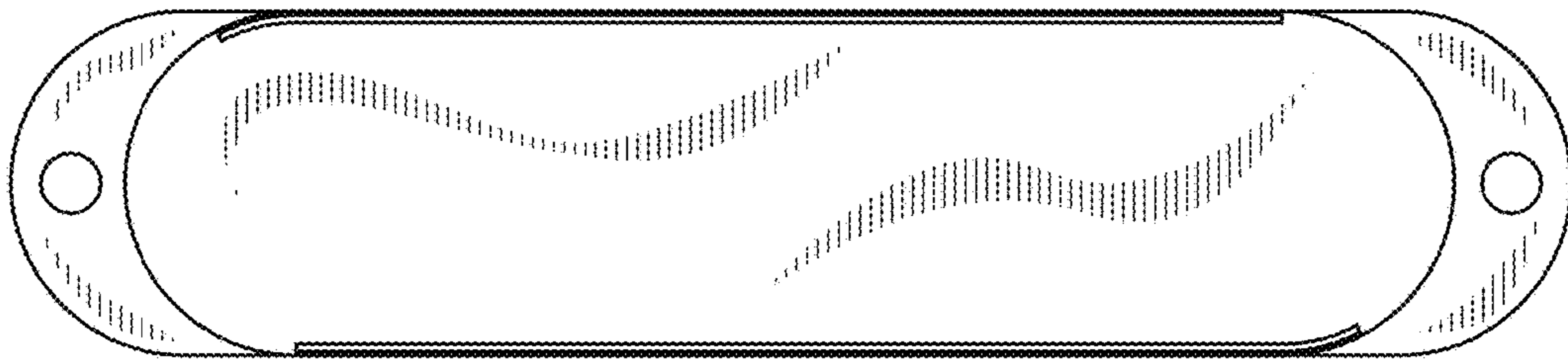

FIG. 4

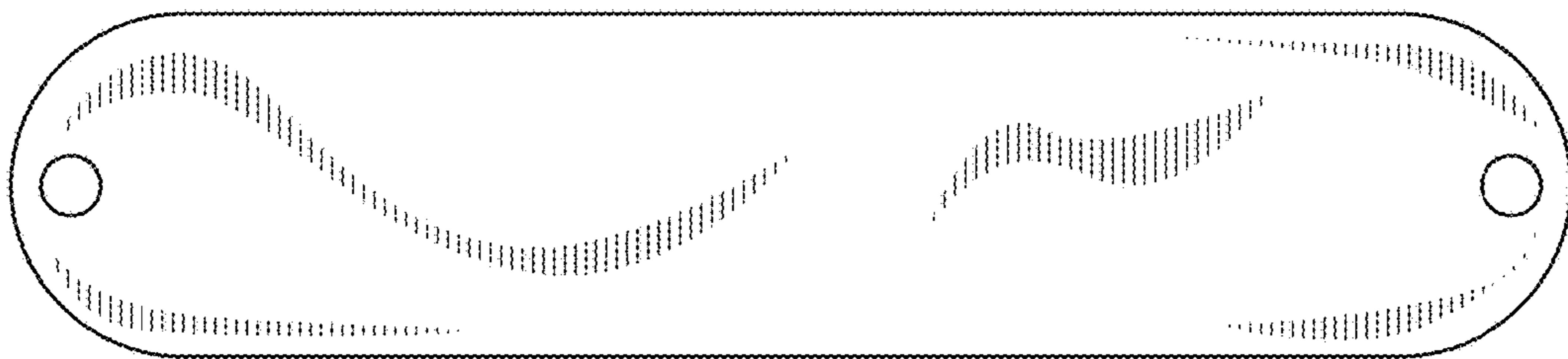

FIG. 5

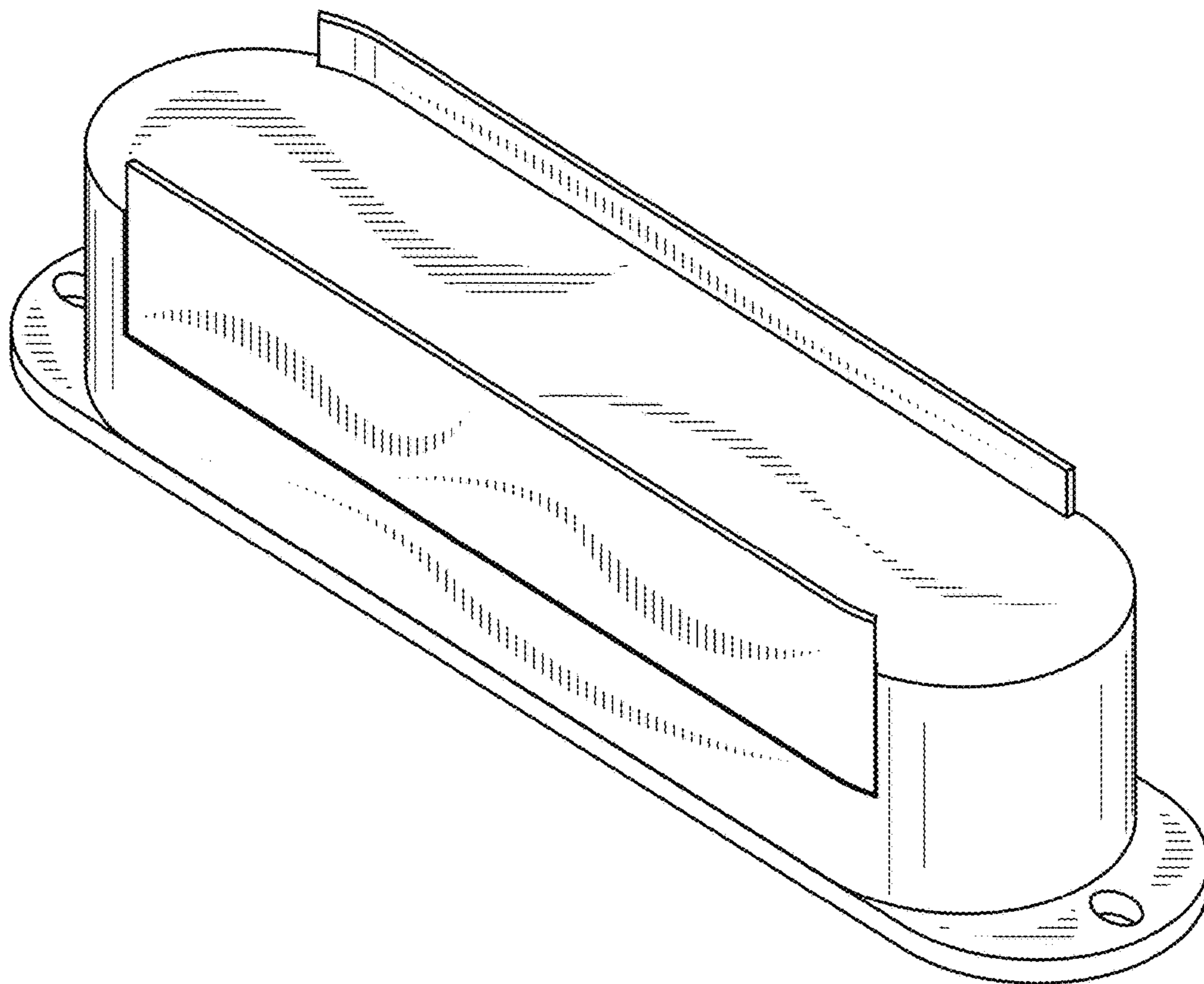

FIG. 6

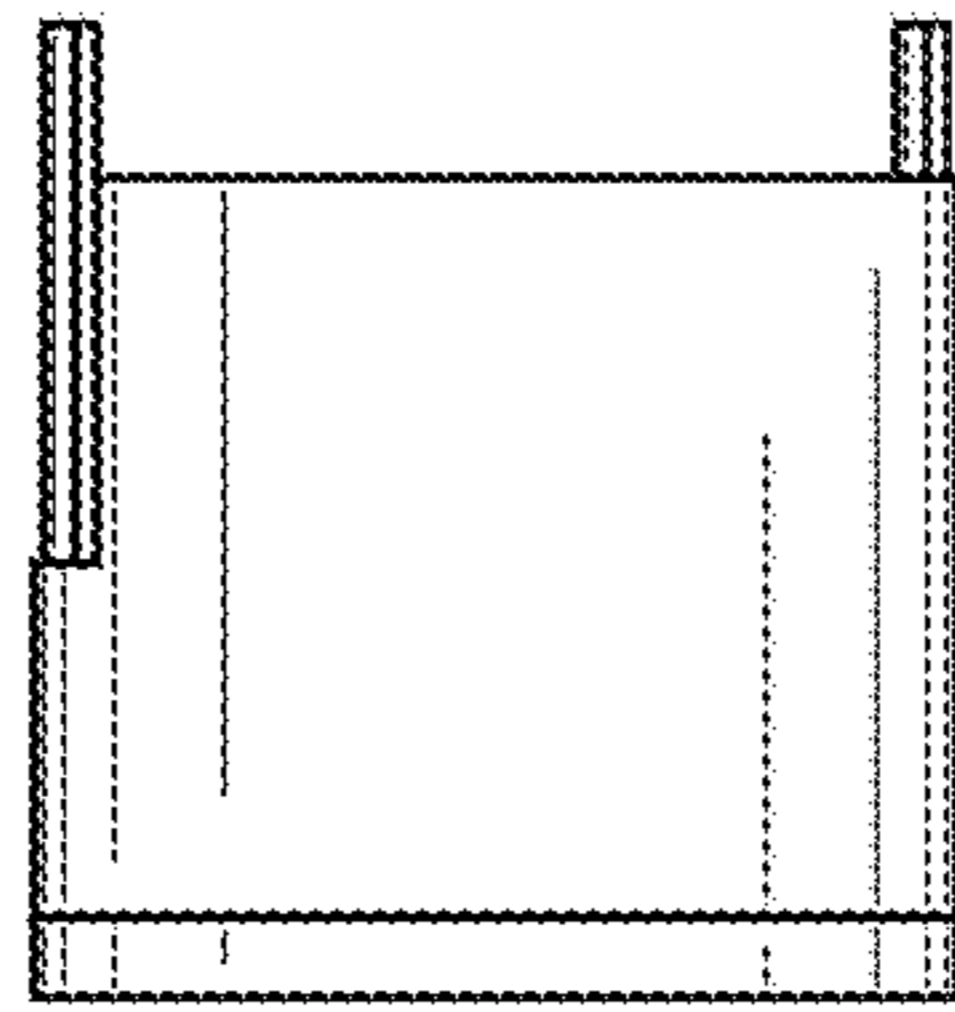

FIG. 7

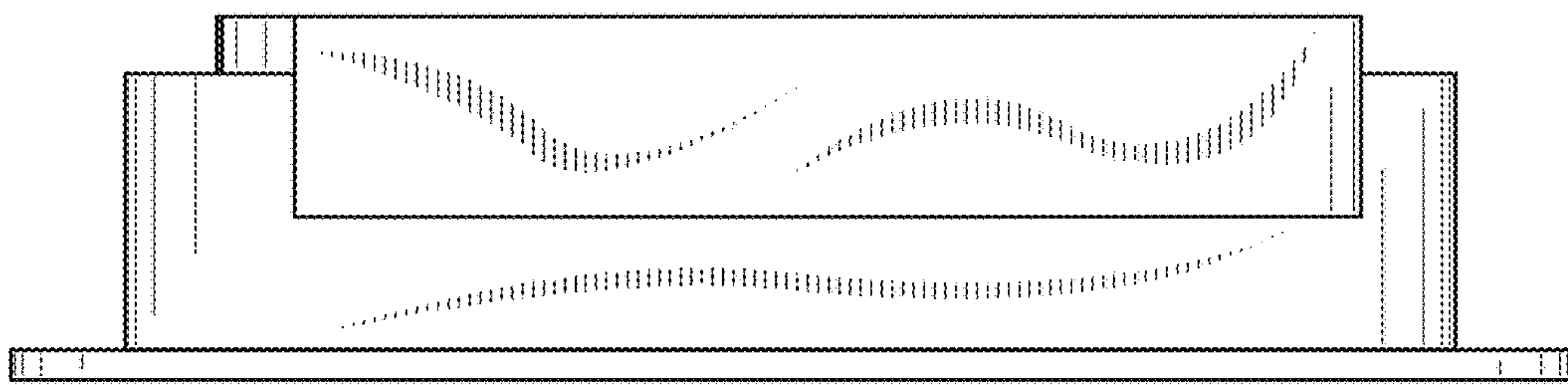

FIG. 8

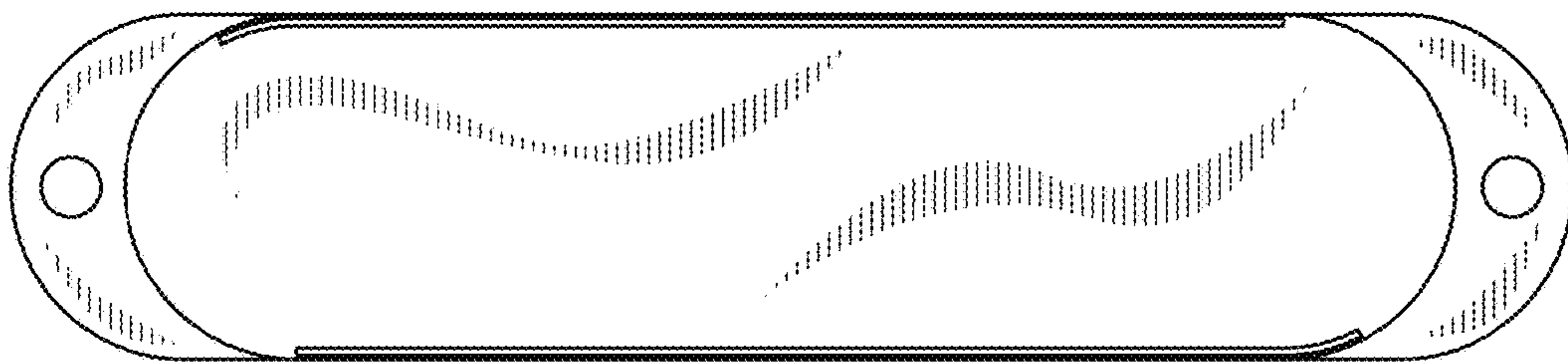

FIG. 9

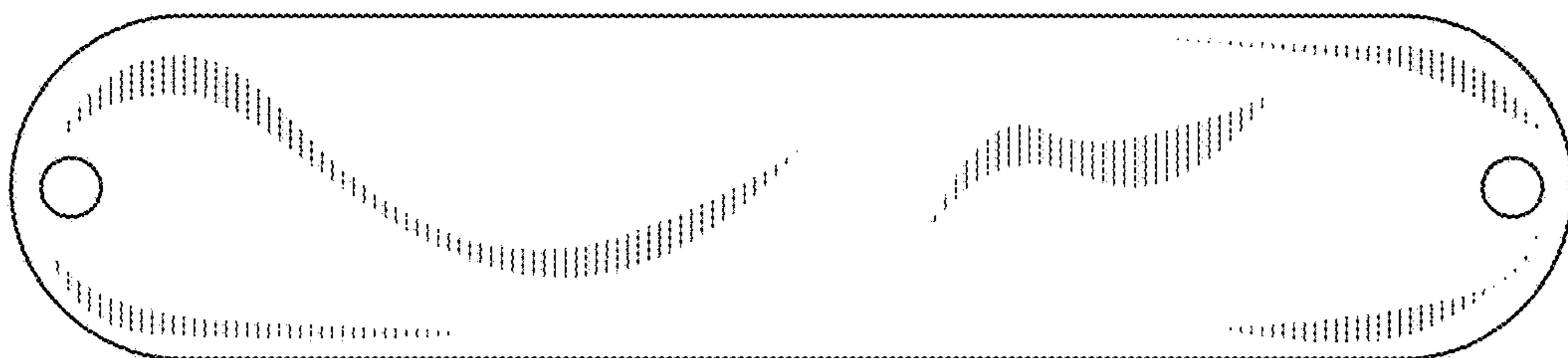

FIG. 10