



US00D817138S

(12) **United States Design Patent** (10) **Patent No.:** **US D817,138 S**
Thompson (45) **Date of Patent:** **** May 8, 2018**

(54) **FASTENING TOOL**

(71) Applicant: **William J. Thompson**, Las Vegas, NV (US)

(72) Inventor: **William J. Thompson**, Las Vegas, NV (US)

(**) Term: **15 Years**

(21) Appl. No.: **29/580,878**

(22) Filed: **Oct. 13, 2016**

(51) **LOC (11) Cl.** **08-05**

(52) **U.S. Cl.**
USPC **D8/68**

(58) **Field of Classification Search**
USPC D8/61, 67, 68
CPC B62D 23/005; B62D 29/00; B62D 29/043;
B62D 31/00; B62D 33/046; B62D 35/00;
B62D 35/001; B60Q 1/0005
See application file for complete search history.

(56) **References Cited**

U.S. PATENT DOCUMENTS

4,147,223	A	4/1979	Swiderski, Jr. et al.	
4,153,193	A	5/1979	Urbanowicz	
4,284,223	A	8/1981	Salcido et al.	
4,479,599	A	10/1984	Conrad	
D337,038	S *	7/1993	Sakamoto	D8/68
5,361,851	A	11/1994	Fox	
5,423,469	A	6/1995	Armstrong	
5,425,488	A	6/1995	Thompson	
5,465,893	A	11/1995	Thompson	
5,544,800	A	8/1996	Armstrong	
5,598,892	A	2/1997	Fox	
D402,872	S *	12/1998	Clowers	D8/68
D406,741	S *	3/1999	Zurwelle	D8/68
D467,481	S *	12/2002	Watson	D8/68
D470,028	S *	2/2003	Cooper	D8/68
7,014,087	B1	3/2006	White et al.	

(Continued)

Primary Examiner — Darlington Ly

(57) **CLAIM**

The ornamental design for a fastening tool, as shown and described.

DESCRIPTION

FIG. 1 is a right side perspective of a fastening tool showing my new design in accordance to a first embodiment;
 FIG. 2 is a front elevational view thereof;
 FIG. 3 is a rear elevational view thereof;
 FIG. 4 is a right side elevational view thereof;
 FIG. 5 is a left side elevational view thereof;
 FIG. 6 is a top plan view thereof;
 FIG. 7 is a bottom plan view thereof;
 FIG. 8 is a right side perspective view a fastening tool showing my new design in accordance to a second embodiment;
 FIG. 9 is a front elevational view thereof;
 FIG. 10 is a rear elevational view thereof;
 FIG. 11 is a right side elevational view thereof;
 FIG. 12 is a left side elevational view thereof;
 FIG. 13 is a top plan view thereof;
 FIG. 14 is a bottom plan view thereof;
 FIG. 15 is a right side perspective view a fastening tool showing my new design in accordance to a third embodiment;
 FIG. 16 is a front elevational view thereof;
 FIG. 17 is a rear elevational view thereof;
 FIG. 18 is a right side elevational view thereof;
 FIG. 19 is a left side elevational view thereof;
 FIG. 20 is a top plan view thereof; and,
 FIG. 21 is a bottom plan view thereof.

The broken lines on the shaft of the fastening tool define the bounds of the claimed design and form no part thereof; all other broken lines showing of the fastening tool is for the purpose of illustrating environmental structure and form no part of the claimed design.

1 Claim, 21 Drawing Sheets

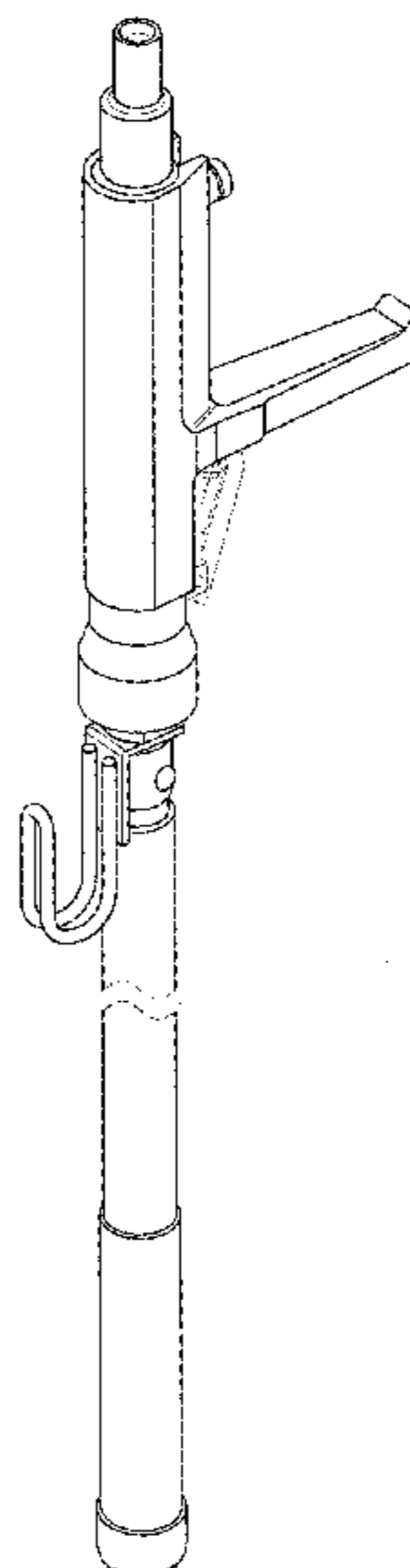

(56)

References Cited

U.S. PATENT DOCUMENTS

7,032,482 B1 * 4/2006 Hoffman B25B 23/045
227/8
7,121,598 B2 10/2006 Pourtier et al.
D534,405 S * 1/2007 Concari D8/68
D592,478 S * 5/2009 Wright D8/68
7,584,879 B2 9/2009 Blessing et al.
7,896,210 B2 3/2011 Popovich et al.
8,726,765 B2 * 5/2014 Hoffman B25B 23/045
81/434
2004/0123704 A1 * 7/2004 Kigel B21J 15/32
81/434
2012/0073410 A1 * 3/2012 Hoffman B25B 23/04
81/434
2012/0210831 A1 * 8/2012 Liang B25B 23/045
81/434
2013/0112046 A1 * 5/2013 Desmond B25B 23/045
81/57

* cited by examiner

FIG. 1

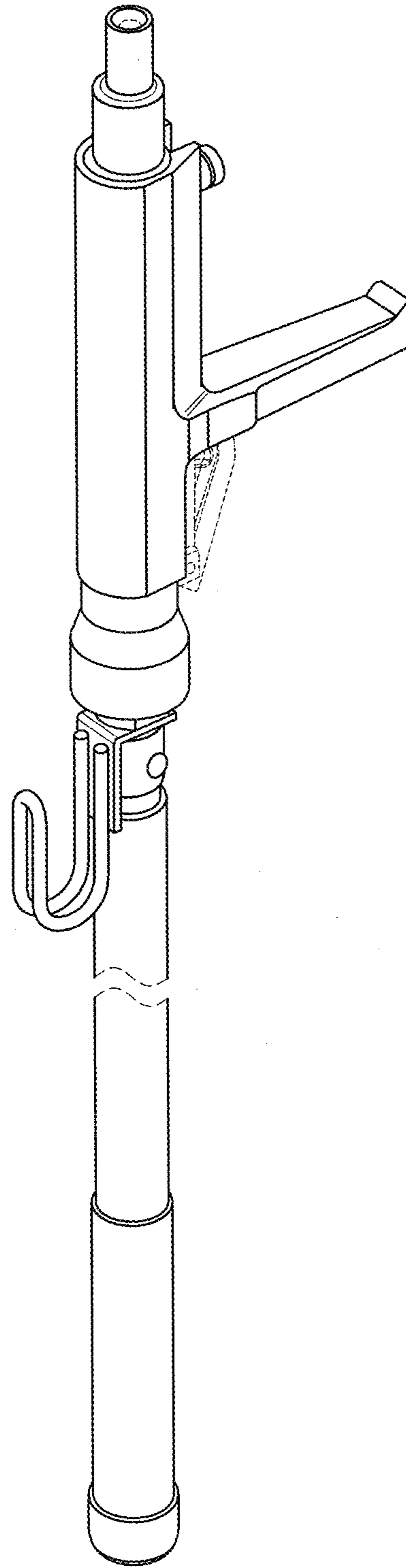

FIG. 2

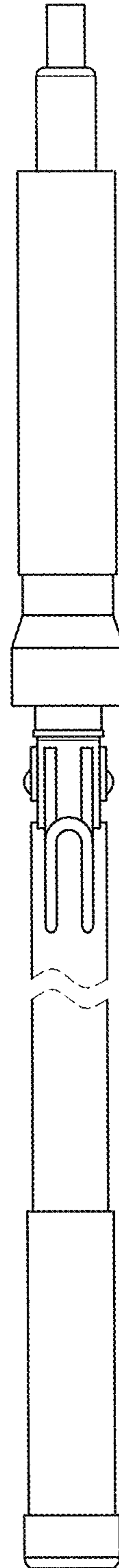

FIG. 3

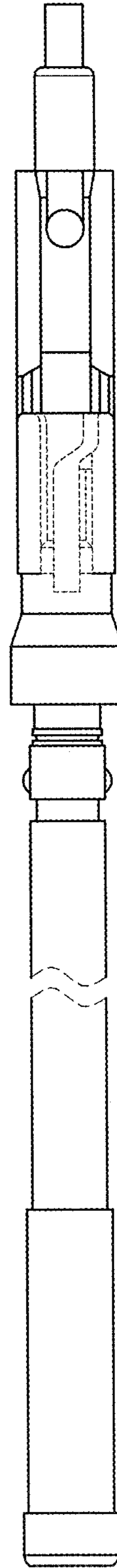

FIG. 4

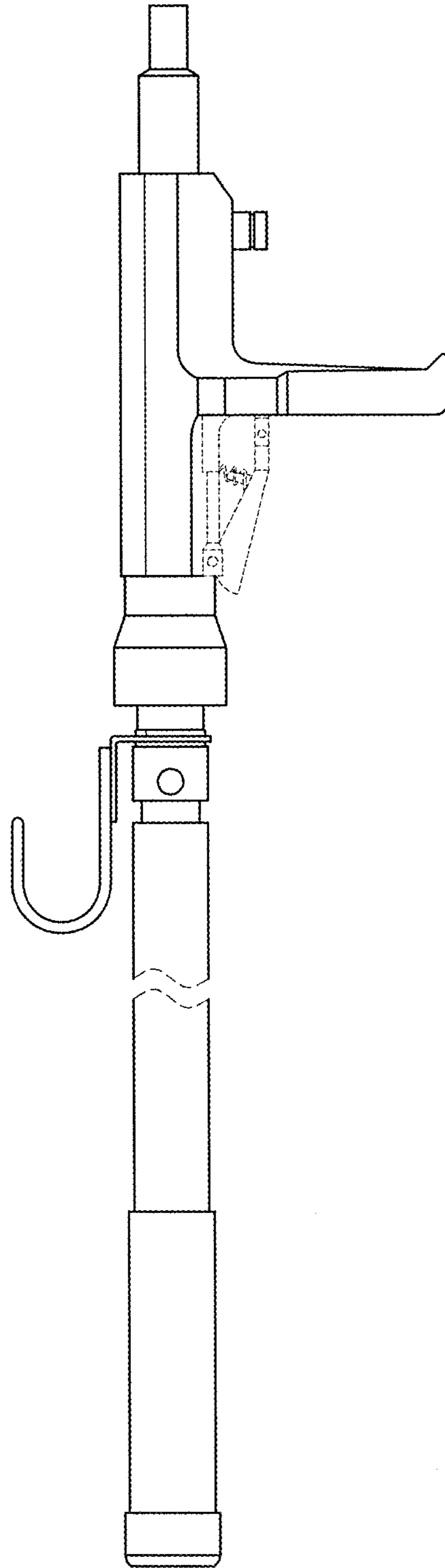
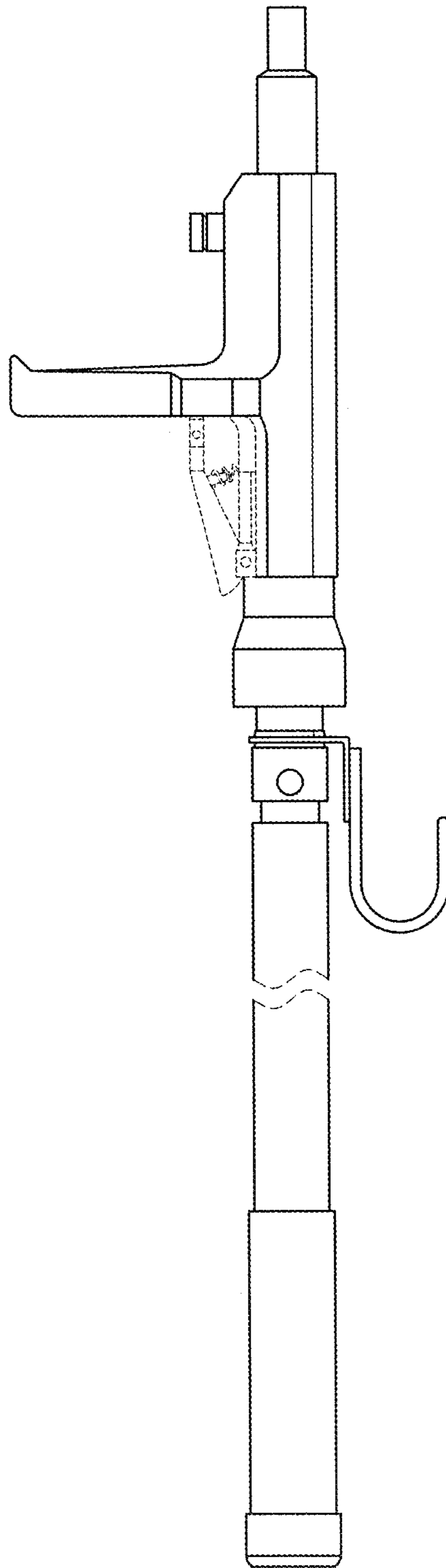

FIG. 5



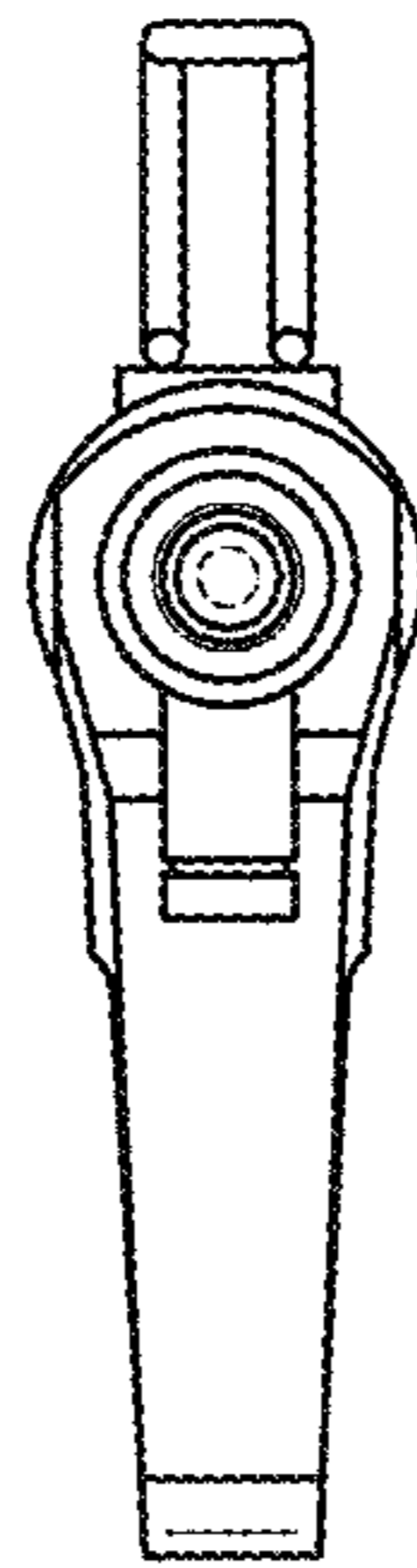

FIG. 6

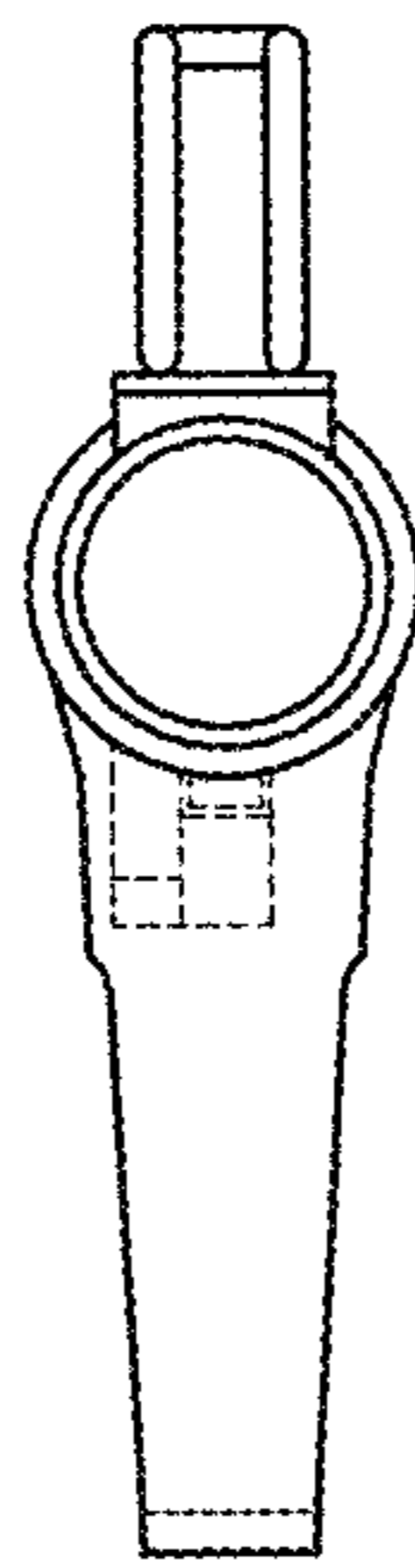

FIG. 7

FIG. 8

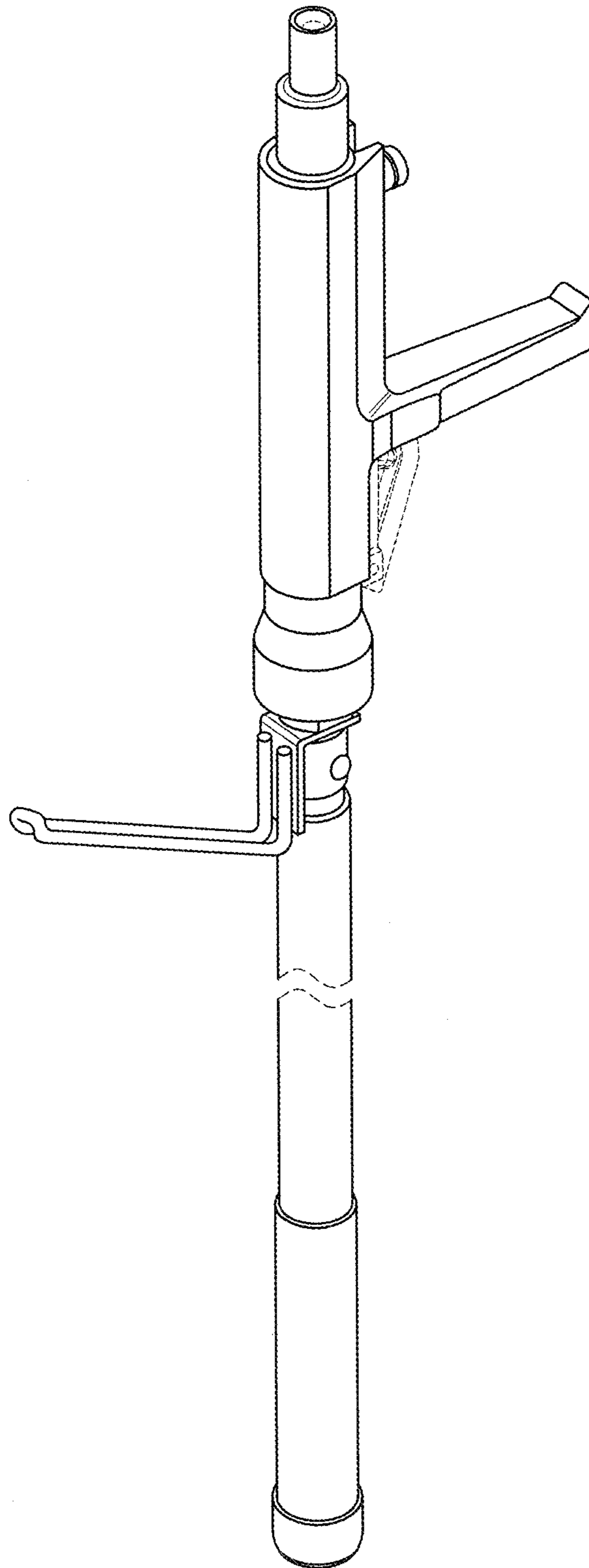

FIG. 9

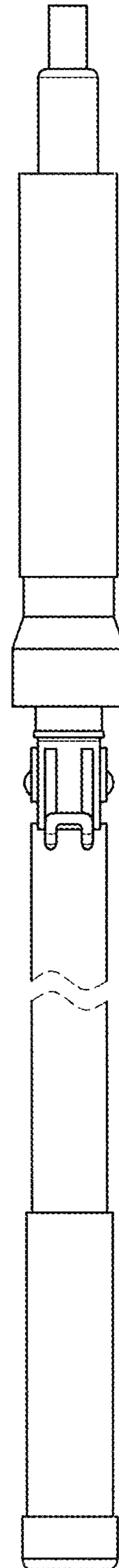

FIG. 10

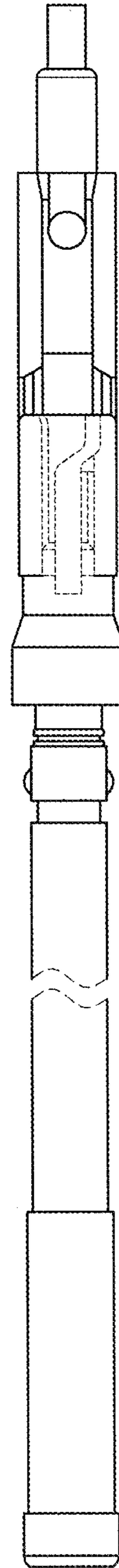

FIG. 11

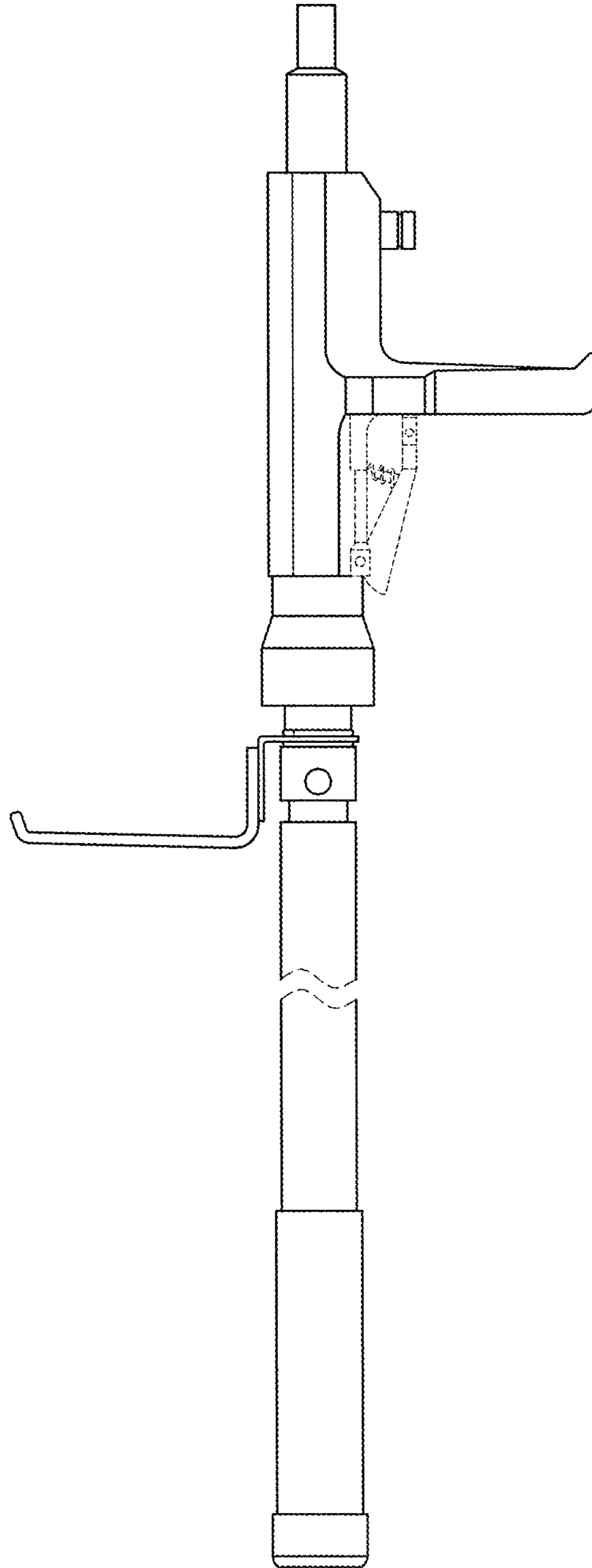
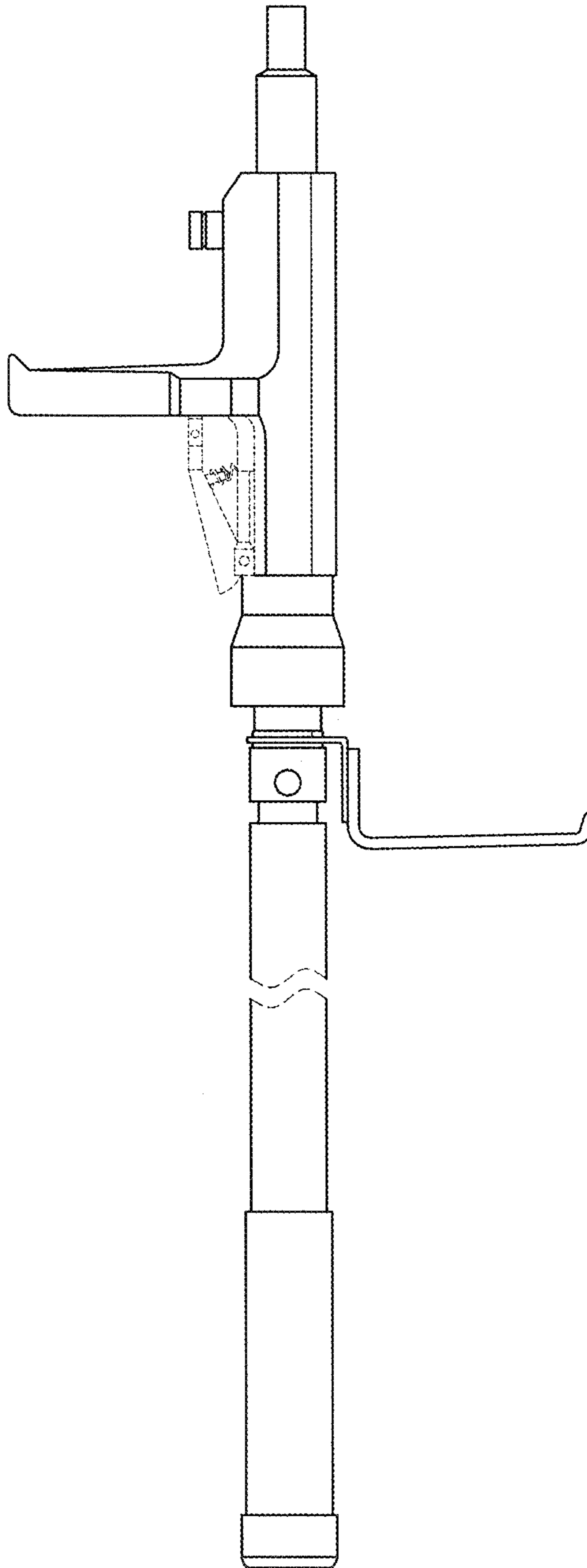

FIG. 12



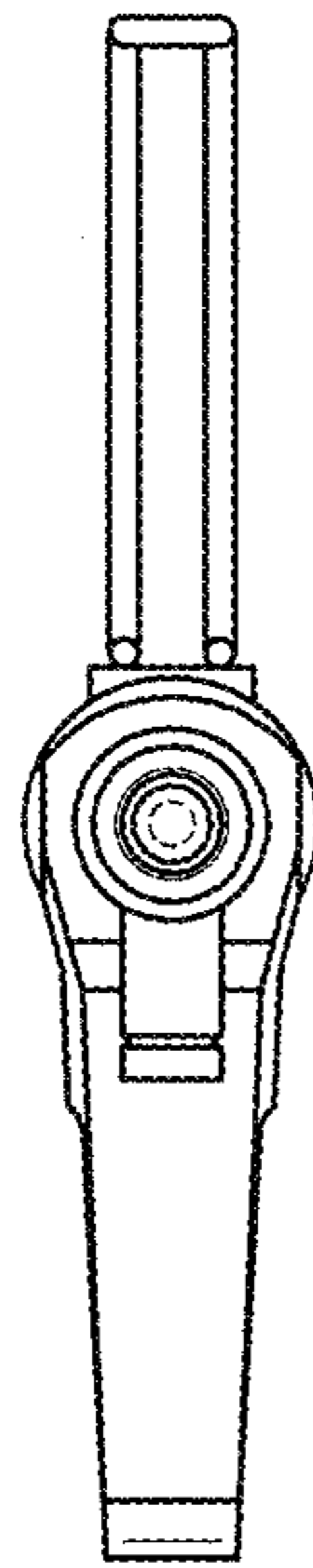

FIG. 13

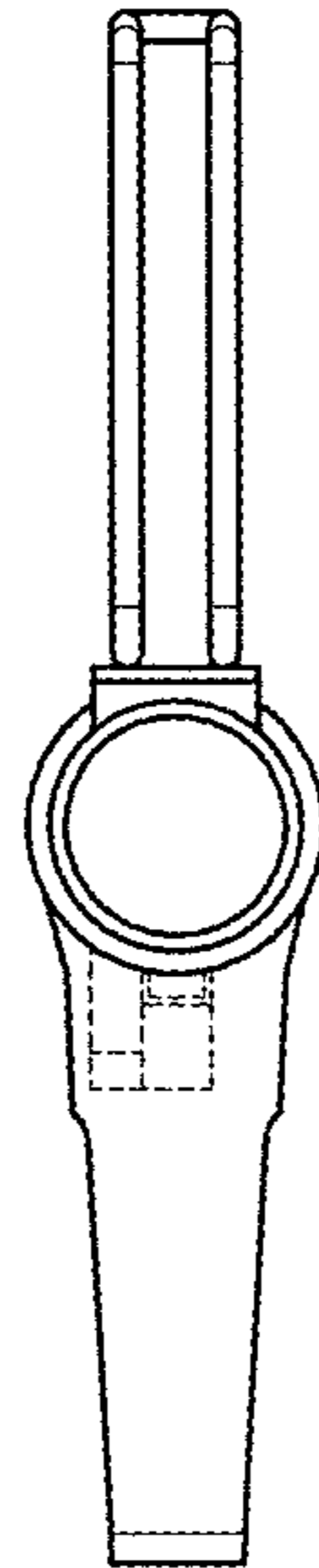

FIG. 14

FIG. 15

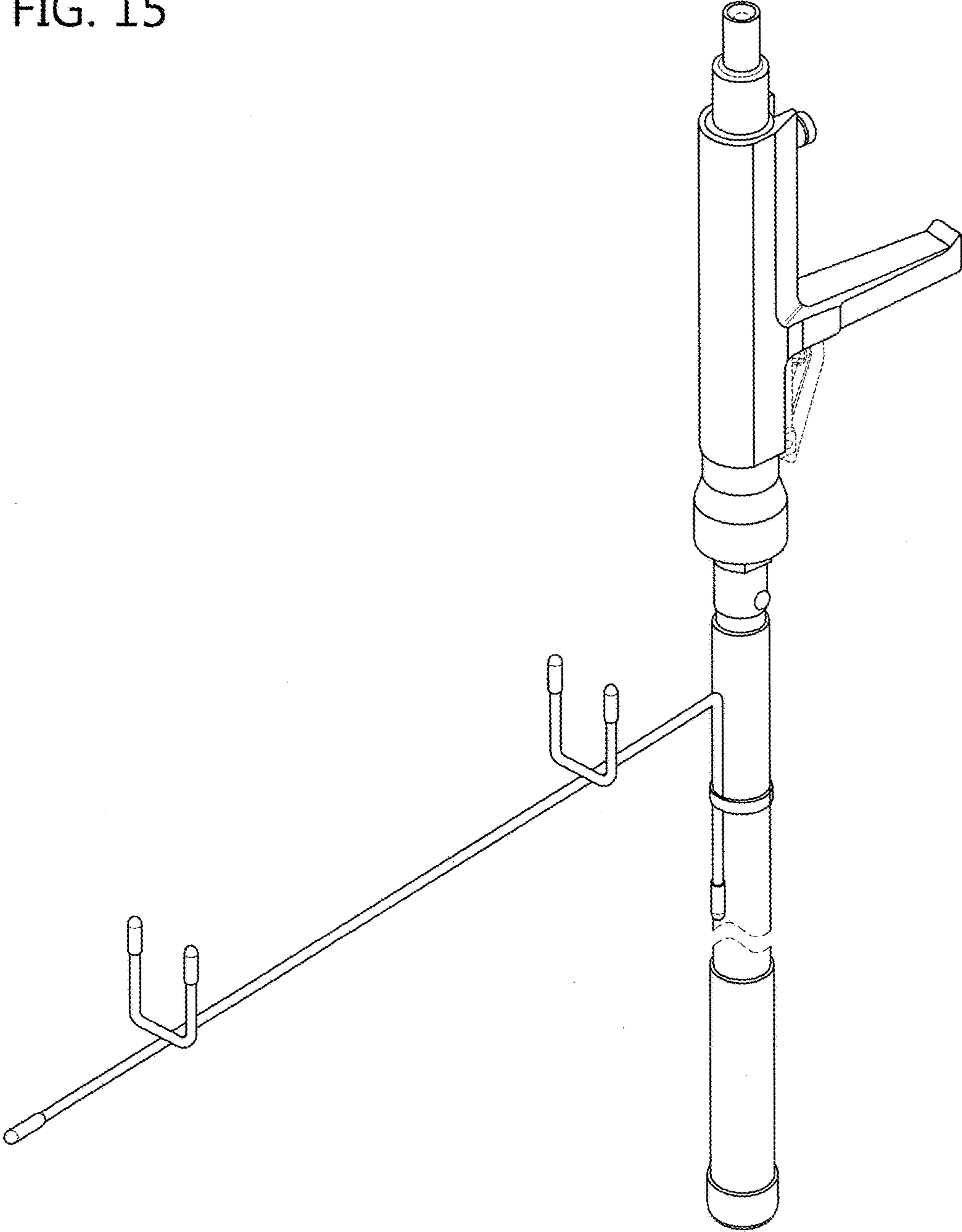

FIG. 16

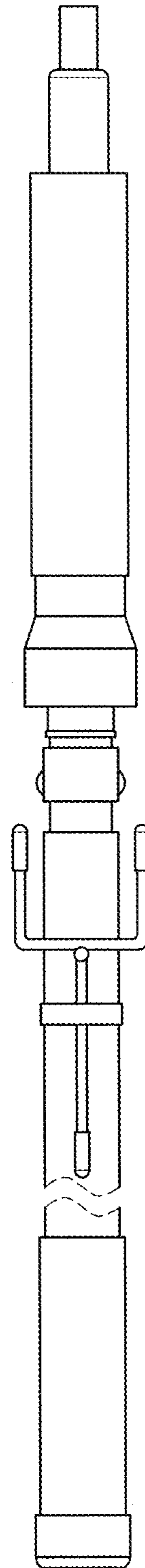

FIG. 17

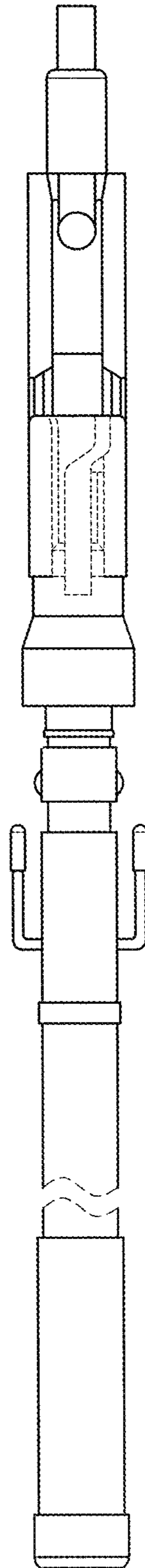

FIG. 18

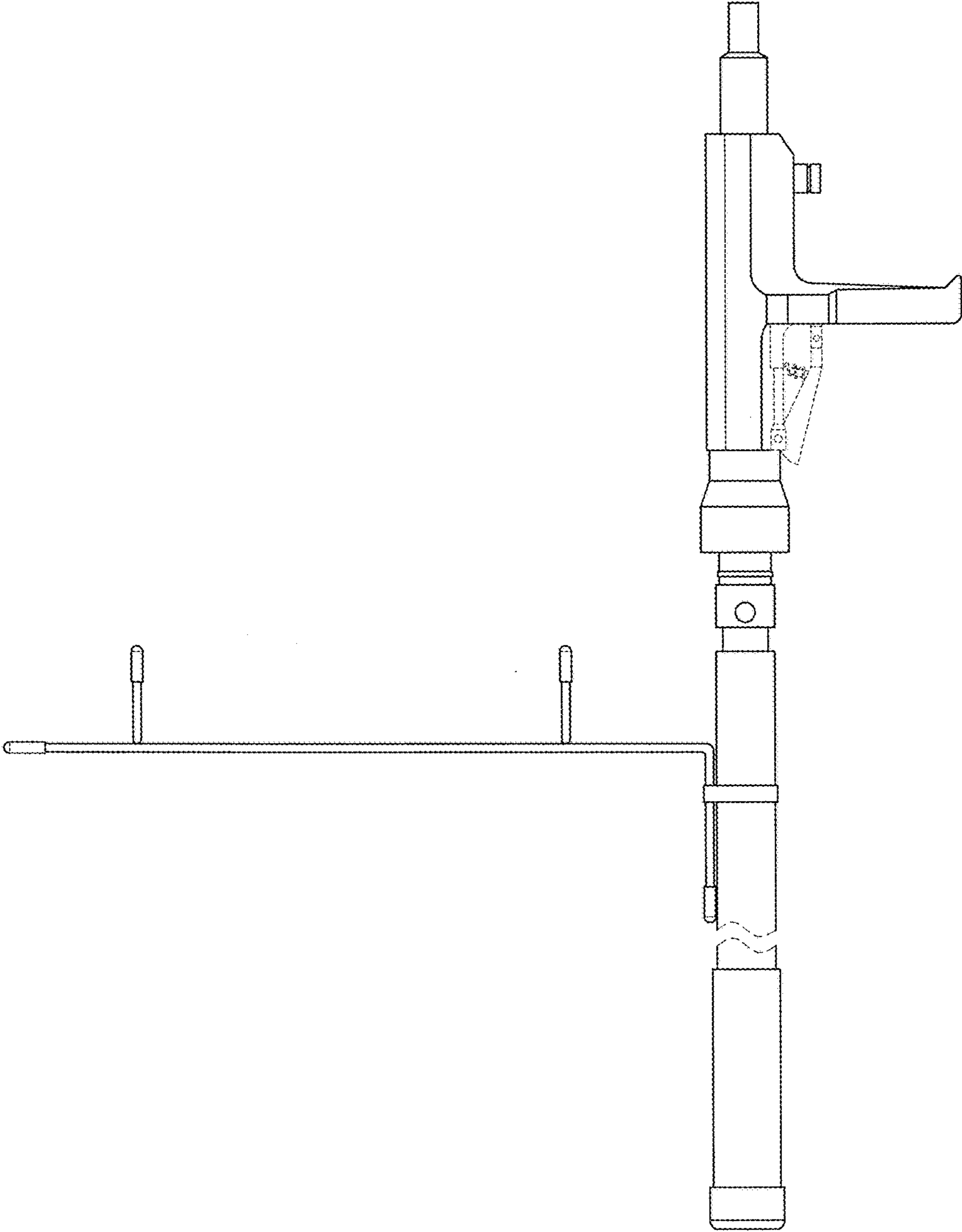
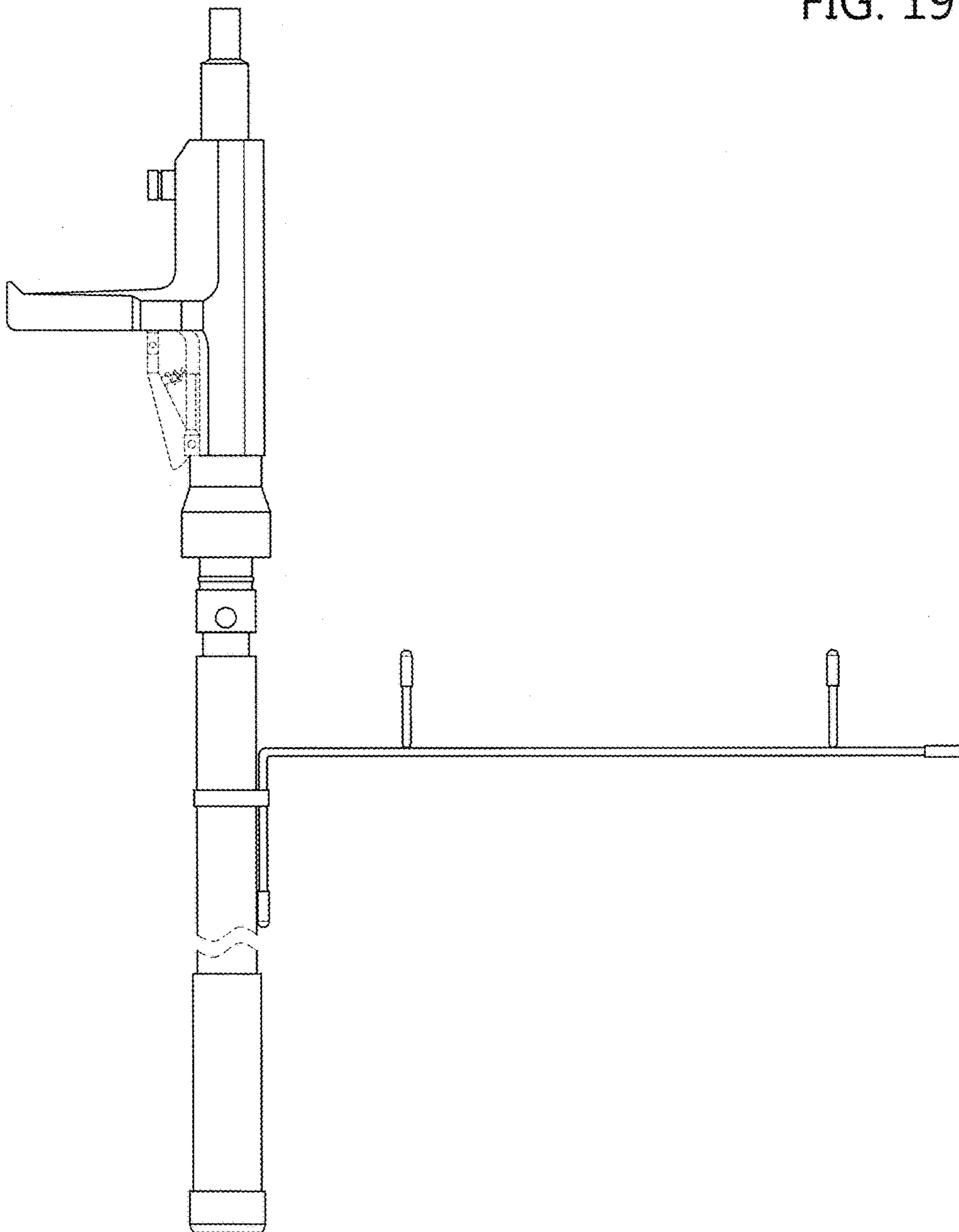

FIG. 19



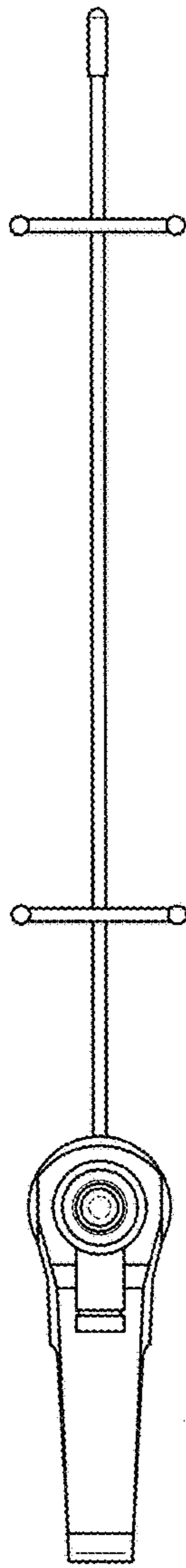

FIG. 20

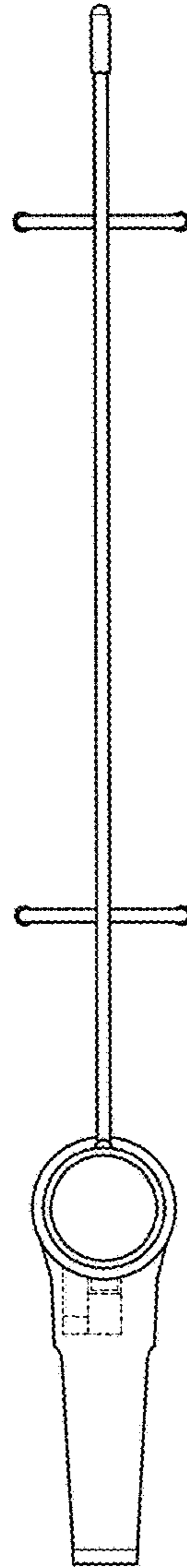

FIG. 21