



US00D816841S

(12) **United States Design Patent** (10) **Patent No.:** **US D816,841 S**
Thome et al. (45) **Date of Patent:** **** May 1, 2018**

(54) **BONE IMPLANT** 3,293,663 A * 12/1966 Cronin A61F 2/12
128/DIG. 21

(71) Applicant: **JJGC INDUSTRIA E COMERCIO DE MATERIAIS DENTARIOS S/A,** 3,481,380 A 12/1969 Breed
Curitiba (BR) 3,672,058 A 6/1972 Nikoghossian
3,797,113 A 3/1974 Brainin
(Continued)

(72) Inventors: **Geninho Thome,** Curitiba (BR); **Felix Andreas Mertin,** Curitiba (BR);
Alexsander Luiz Golin, Curitiba (BR); **Ilderaldo Jose Lucca,** Curitiba (BR)
BR MU8801468 U2 11/2009
BR PI0902500 A2 4/2011
(Continued)

FOREIGN PATENT DOCUMENTS

(73) Assignee: **JJGC Industria E Comercio De Materiais Dentarios S/A,** Curitiba, Parana (BR)

OTHER PUBLICATIONS

(**) Term: **15 Years** U.S. Appl. No. 14/874,145, filed Oct. 2, 2015, Thome, et al.
(Continued)

(21) Appl. No.: **29/530,135**
(22) Filed: **Jun. 12, 2015**
Primary Examiner — Charles D Hanson
(74) *Attorney, Agent, or Firm* — Foley & Lardner LLP; Christopher C. Bolten; Christopher M. King

(30) **Foreign Application Priority Data** (57) **CLAIM**

Dec. 15, 2014 (BR) 3020140063120
(51) **LOC (11) Cl.** **24-02**
(52) **U.S. Cl.**
USPC **D24/155**
We claim the ornamental design for a bone implant, as shown and described.

(58) **Field of Classification Search** (57) **DESCRIPTION**
USPC D24/155-157
CPC A61C 8/00; A61C 8/0089; A61C 8/0069;
A61C 8/0054; A61C 8/0096; A61C 8/0039; A61C 8/0063; A61C 8/006; A61C 8/0001; A61C 8/0012; A61C 8/0075; A61C 8/0083; A61C 13/225
See application file for complete search history.
FIG. 1 is a front perspective view from below of the claimed design;
FIG. 2 is a bottom view from above of the claimed design of FIG. 1;
FIG. 3 is a left side view of the claimed design of FIG. 1, the right side view is identical to the left side view;
FIG. 4 is a front view of the claimed design of FIG. 1, the rear view is identical to the front view;
FIG. 5 is a front perspective view from above of the claimed design of FIG. 1; and,
FIG. 6 is a top view of the claimed design of FIG. 1.
Any portion of the article depicted in broken lines forms no part of the claimed design.

(56) **References Cited** **1 Claim, 3 Drawing Sheets**
U.S. PATENT DOCUMENTS
422,307 A 2/1890 Libbey
1,698,951 A 1/1929 Holmes
2,215,770 A 9/1940 Sheffield
2,788,046 A 4/1957 Rosan

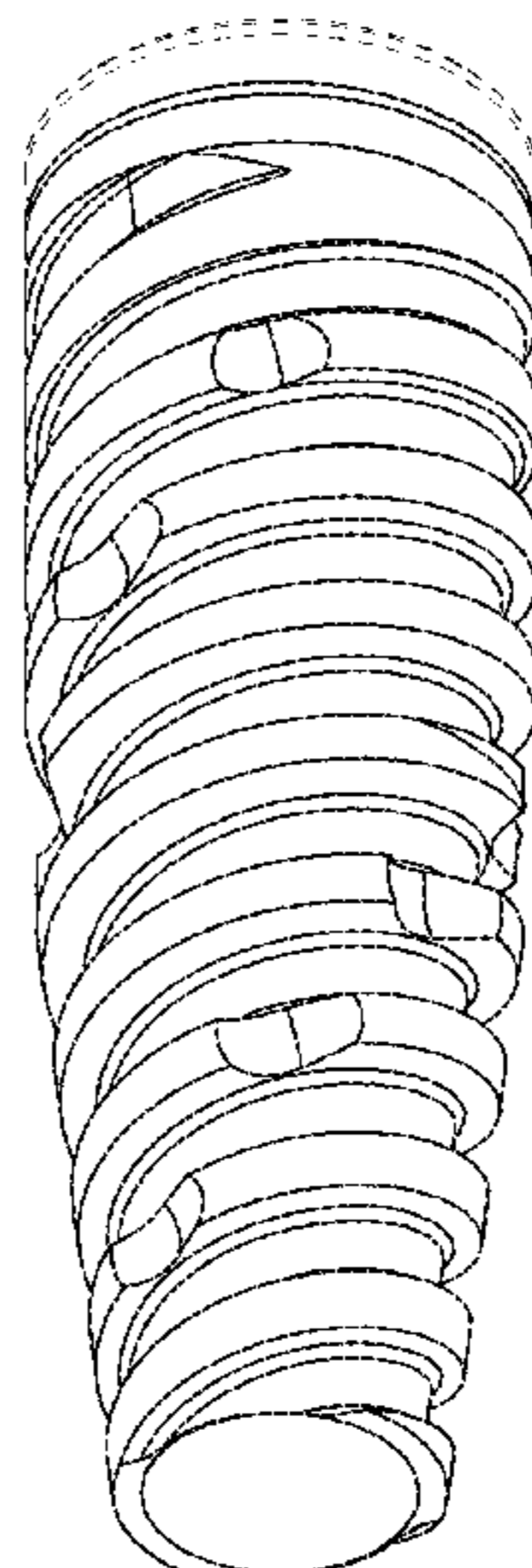

(56)

References Cited

U.S. PATENT DOCUMENTS

3,849,887 A	11/1974	Brainin	5,823,777 A	10/1998	Misch et al.
4,103,422 A	8/1978	Weiss et al.	5,858,079 A	1/1999	Ohtsu et al.
4,144,795 A	3/1979	Gutshall	5,868,747 A	2/1999	Ochoa et al.
4,293,302 A	10/1981	Hassler et al.	5,871,356 A	2/1999	Guedj
4,406,623 A	9/1983	Grafelmann et al.	5,876,453 A	3/1999	Beaty
4,431,416 A	2/1984	Niznick	5,897,319 A	4/1999	Wagner et al.
4,468,200 A	8/1984	Munch	5,915,968 A	6/1999	Kirsch et al.
4,531,915 A	7/1985	Tatum, Jr.	5,931,675 A	8/1999	Callan
4,547,157 A	10/1985	Driskell	5,938,444 A	8/1999	Hansson et al.
4,645,453 A	2/1987	Niznick	5,954,504 A	9/1999	Misch et al.
4,713,003 A	12/1987	Symington et al.	5,964,768 A	10/1999	Huebner
4,723,913 A	2/1988	Bergman	5,967,783 A	10/1999	Ura
4,738,623 A	4/1988	Driskell	6,039,568 A	3/2000	Hinds
4,740,208 A *	4/1988	Cavon A61F 2/12 623/8	6,048,204 A	4/2000	Klardie et al.
4,758,161 A	7/1988	Niznick	6,068,479 A	5/2000	Kwan
4,826,434 A	5/1989	Krueger	6,116,904 A	9/2000	Kirsch et al.
4,863,383 A	9/1989	Grafelmann	6,129,730 A	10/2000	Bono et al.
4,865,603 A	9/1989	Noiles	6,135,772 A	10/2000	Jones
4,932,868 A	6/1990	Linkow et al.	6,149,432 A	11/2000	Shaw et al.
4,960,381 A	10/1990	Niznick	6,168,633 B1	1/2001	Shoher et al.
4,976,739 A	12/1990	Duthie, Jr.	6,200,345 B1	3/2001	Morgan
5,000,686 A	3/1991	Lazzara et al.	6,227,857 B1	5/2001	Morgan et al.
5,002,488 A	3/1991	Homsy	6,227,859 B1	5/2001	Sutter
5,007,835 A	4/1991	Valen	6,273,722 B1	8/2001	Phillips
5,061,181 A	10/1991	Niznick	6,283,754 B1	9/2001	Wohrle
5,062,800 A	11/1991	Niznick	6,287,117 B1	9/2001	Niznick
5,071,350 A	12/1991	Niznick	D450,123 S *	11/2001	Atkin D24/155
5,074,790 A	12/1991	Bauer	6,312,259 B1	11/2001	Kvarnstrom et al.
5,076,788 A	12/1991	Niznick	6,315,564 B1	11/2001	Levisman
RE33,796 E	1/1992	Niznick	6,364,663 B1	4/2002	Dinkelacker
5,078,607 A	1/1992	Niznick	6,371,709 B1	4/2002	Papafotiou et al.
5,087,201 A	2/1992	Mondani et al.	6,394,806 B1	5/2002	Kumar
5,095,817 A	3/1992	Takamura	6,398,786 B1	6/2002	Sesic
5,120,171 A	6/1992	Lasner	6,402,515 B1	6/2002	Palti et al.
5,194,000 A	3/1993	Dury	6,419,491 B1	7/2002	Ricci et al.
5,195,892 A	3/1993	Gersberg	6,431,869 B1	8/2002	Reams et al.
5,226,766 A	7/1993	Lasner	6,481,760 B1	11/2002	Noel et al.
5,230,590 A	7/1993	Bohannan et al.	6,482,076 B1	11/2002	Straub et al.
5,328,371 A	7/1994	Hund et al.	6,527,554 B2	3/2003	Hurson et al.
5,343,391 A	8/1994	Mushabac	6,547,564 B1	4/2003	Hansson
5,427,527 A	6/1995	Niznick et al.	6,626,671 B2	9/2003	Klardie et al.
5,433,606 A	7/1995	Niznick et al.	6,648,643 B2	11/2003	Hollander et al.
5,435,723 A	7/1995	O'Brien	6,655,961 B2	12/2003	Cottrell
5,439,381 A	8/1995	Cohen	6,655,962 B1	12/2003	Kennard
5,484,286 A	1/1996	Hansson	6,667,701 B1	12/2003	Tao
5,527,183 A	6/1996	O'Brien	6,726,481 B1	4/2004	Zickmann et al.
5,571,017 A	11/1996	Niznick	6,726,689 B2	4/2004	Jackson
5,580,246 A	12/1996	Fried et al.	6,733,291 B1	5/2004	Hurson
5,584,629 A	12/1996	Bailey et al.	6,733,503 B2	5/2004	Layrolle et al.
5,588,838 A	12/1996	Hansson et al.	6,769,913 B2	8/2004	Hurson
5,593,410 A	1/1997	Vrespa	6,840,769 B2	1/2005	Augthun et al.
D378,132 S *	2/1997	Strain D24/155	6,846,180 B1	1/2005	Joos
5,601,429 A	2/1997	Blacklock	6,887,077 B2	5/2005	Porter et al.
5,628,630 A	5/1997	Misch et al.	6,896,517 B1	5/2005	Bjorn et al.
5,639,237 A	6/1997	Fontenot	6,913,465 B2	7/2005	Howlett et al.
5,642,996 A	7/1997	Mochida et al.	6,955,258 B2	10/2005	Howlett et al.
5,645,740 A	7/1997	Naiman et al.	6,981,873 B2	1/2006	Choi et al.
D382,962 S *	8/1997	Schaffner D24/155	6,997,711 B2	2/2006	Miller
D383,541 S *	9/1997	Strain D24/155	7,008,227 B2	3/2006	Carmichael et al.
5,674,072 A	10/1997	Moser et al.	7,014,464 B2	3/2006	Niznick
5,702,445 A	12/1997	Branemark	7,108,510 B2	9/2006	Niznick
5,716,412 A	2/1998	Decarlo et al.	7,198,488 B2	4/2007	Lang et al.
5,725,375 A	3/1998	Rogers	7,207,800 B1	4/2007	Kwan
5,727,943 A	3/1998	Beaty et al.	7,210,933 B2	5/2007	Haessler
5,733,123 A	3/1998	Blacklock et al.	7,249,949 B2	7/2007	Carter
5,752,830 A	5/1998	Suarez	7,273,373 B2	9/2007	Horiuchi
5,759,034 A	6/1998	Daftary	7,281,925 B2	10/2007	Hall
5,782,918 A	7/1998	Klardie et al.	7,341,454 B2	3/2008	Balfour et al.
5,795,160 A	8/1998	Hahn et al.	7,377,781 B1	5/2008	Karapetyan
5,810,589 A	9/1998	Michnick et al.	7,383,163 B2	6/2008	Holberg
5,810,590 A	9/1998	Fried et al.	D605,767 S *	12/2009	Laurysen D2/853
5,816,812 A	10/1998	Kownacki et al.	D612,498 S *	3/2010	Johnson D24/155
5,820,374 A	10/1998	Simmons et al.	7,677,891 B2	3/2010	Niznick
5,823,776 A	10/1998	Duerr et al.	D616,096 S *	5/2010	Laurysen D2/853
			7,806,693 B2	10/2010	Hurson
			8,016,594 B2	9/2011	Ferris et al.
			8,029,285 B2	10/2011	Holmen et al.
			D648,436 S *	11/2011	Stelter D24/155
			8,066,511 B2	11/2011	Wohrle et al.

(56)

References Cited

U.S. PATENT DOCUMENTS

8,083,442 B2 12/2011 Pan
 D653,758 S * 2/2012 Stelter D24/155
 D662,593 S * 6/2012 Prosser D24/155
 8,192,199 B2 6/2012 Arni
 8,221,119 B1 7/2012 Valen
 8,277,218 B2 10/2012 D'Alise
 8,408,904 B2 4/2013 Purga et al.
 8,485,819 B2 7/2013 Callan
 8,491,302 B2 7/2013 Arni
 8,714,977 B2 5/2014 Fromovich et al.
 8,758,012 B2 6/2014 Hurson
 8,764,443 B2 7/2014 Hall
 8,858,230 B2 10/2014 Hsieh
 8,870,573 B2 10/2014 Hung
 9,220,582 B2 12/2015 Thome et al.
 2001/0000748 A1 5/2001 Rogers et al.
 2002/0064758 A1 5/2002 Lee
 2002/0102518 A1 8/2002 Mena
 2002/0106612 A1 8/2002 Back et al.
 2002/0177106 A1 11/2002 May et al.
 2003/0064349 A1 4/2003 Simmons
 2003/0124487 A1 7/2003 McDevitt
 2004/0006346 A1 1/2004 Holmen et al.
 2004/0033469 A1 2/2004 Blacklock
 2004/0063069 A1 4/2004 Lombardi
 2004/0063071 A1 4/2004 Schroering
 2005/0053897 A1 3/2005 Wu
 2005/0100863 A1 5/2005 Chang
 2005/0214714 A1 9/2005 Wohrle
 2005/0244789 A1 11/2005 Crohin et al.
 2005/0260540 A1 11/2005 Hall
 2005/0266381 A1 12/2005 Abarno
 2005/0287497 A1 12/2005 Carter
 2006/0003290 A1 1/2006 Niznick
 2006/0078847 A1 4/2006 Kwan
 2006/0099153 A1 5/2006 Kato et al.
 2006/0147880 A1 7/2006 Krumsiek et al.
 2006/0172257 A1 8/2006 Niznick
 2006/0172258 A1 8/2006 Niznick
 2006/0183078 A1 8/2006 Niznick
 2006/0223030 A1 10/2006 Dinkelacker
 2007/0065778 A1 3/2007 Lippe
 2007/0287128 A1 12/2007 Claudio et al.
 2008/0014556 A1 1/2008 Neumeyer
 2008/0032264 A1 2/2008 Hall
 2008/0182227 A1 7/2008 Wolf et al.
 2008/0187886 A1 8/2008 Robb
 2008/0293014 A1 11/2008 Chung
 2009/0220914 A1 9/2009 Gershenzon
 2009/0233256 A1 9/2009 Schroering
 2009/0305191 A1 12/2009 Jandali
 2010/0092920 A1 4/2010 Hsieh
 2010/0190138 A1 7/2010 Giorno
 2011/0027756 A1 2/2011 Benatouil et al.
 2011/0097689 A1 4/2011 Thome
 2011/0117522 A1 5/2011 Verma et al.
 2011/0123953 A1 5/2011 Jorneus et al.
 2011/0143317 A1 6/2011 Thome
 2011/0244427 A1 10/2011 Hung
 2011/0294094 A1 12/2011 Moshavi
 2012/0077151 A1 3/2012 Filho et al.
 2012/0135378 A1 5/2012 Thome
 2012/0156647 A1 6/2012 Yoon et al.
 2012/0178048 A1 7/2012 Cottrell
 2012/0237898 A1 9/2012 Palti et al.
 2012/0237899 A1 9/2012 Holmstrom et al.
 2012/0237900 A1 9/2012 Lancieux et al.
 2012/0288824 A1 11/2012 Nordin et al.
 2013/0045144 A1 2/2013 Perozziello et al.
 2013/0177874 A1 7/2013 Hori et al.
 2013/0224687 A1 8/2013 Karmon
 2013/0260339 A1 10/2013 Reddy et al.
 2013/0273500 A1 10/2013 Giorno
 2013/0309630 A1 11/2013 Bolleter
 2014/0045144 A1 2/2014 Dukhan

2014/0186799 A1 7/2014 Pan et al.
 2014/0234800 A1 8/2014 Laster
 2015/0044638 A1 2/2015 Baez
 2015/0111175 A1 4/2015 Thome et al.
 2015/0230889 A1 8/2015 Kim
 2015/0297321 A1 10/2015 Chen
 2016/0166358 A1 6/2016 Thome et al.

FOREIGN PATENT DOCUMENTS

CN 203029412 U 7/2013
 DE 39 04 528 A1 8/1990
 DE 102 31 743 A1 2/2004
 EP 0 707 835 A1 4/1996
 EP 0 819 410 A1 1/1998
 EP 0 895 757 A1 2/1999
 EP 1 396 236 A1 3/2004
 EP 1 728 486 A1 12/2006
 EP 2 145 600 A1 1/2010
 FR 2600246 A1 12/1987
 FR 2610512 A1 8/1988
 JP H08-19555 A 1/1996
 RU 2190373 C1 10/2002
 RU 2202982 C1 4/2003
 WO WO-01/49199 A2 7/2001
 WO WO-03/005928 A1 1/2003
 WO WO-2006/026938 A1 3/2006
 WO WO-2006/082050 A1 8/2006
 WO WO-2007/091997 A1 8/2007
 WO WO-2008/096294 A1 8/2008
 WO WO-2008/157137 A1 12/2008
 WO WO-2009/007891 A1 1/2009
 WO WO-2009/054005 A2 4/2009
 WO WO-2009/130415 A2 10/2009
 WO WO-2011/083400 A2 7/2011
 WO WO-2011/132007 A2 10/2011
 WO WO-2012/007118 A1 1/2012
 WO WO-2012/059908 A1 5/2012
 WO WO-2012/075614 A1 6/2012
 WO WO-2012/123661 A1 9/2012
 WO WO-2012/126466 A1 9/2012
 WO WO-2013/004703 A1 1/2013
 WO WO-2013/068088 A1 5/2013
 WO WO-2006/094997 A1 6/2016

OTHER PUBLICATIONS

ADIN Dental Implant Systems, Tourag (TM)-S, Website Catalog, 2 pages, Sep. 14, 2014.
 AlphaBio Product Catalog, 16 pages (1995).
 AlphaBio System Product Catalog, 53 pages, Mar. 2003.
 Anthogyr Implants SAS Catalog, The Implantology Serenly, 40 pages (2002).
 Bicon Dental Implants Catalog, 7 pages (1997).
 Hansson, The Implant Neck: Smooth or Provided With Retention Elements, A Biomechanical Approach, Clin. Oral Impl. Res, 10:394-405 (1999).
 Intradent Catalog—"Facility Implants—The Solution For Narrow Restorative Spaces", 4 pages (2014).
 Intradent Catalog—"Neodent—20 Years of Advancement in Implantology", 8 pages (2013).
 Intradent Catalog—"One Step Hybrid—The Definitive Solution For The Immediate Loading of a Full Arch Prosthesis", 8 pages (2014).
 Intradent Catalog—"The CM Implant Line", 8 pages (2013).
 Intradent Catalog—"The CM Implant Line-Overview", 2 pages (2013).
 Intradent Catalog—"The Smart Implant Line—External Hex—Overview", 2 pages (2013).
 Intradent Catalog—"The Smart Implant Line—External Hex, A Classic in Versatility", 8 pages (2013).
 Intradent Catalog—"The WS Implant Line—Overview", 2 pages (2013).

(56)

References Cited

OTHER PUBLICATIONS

Judy, et al., Improved Technique of endodontic stabilization—biofunctional considerations, *Oral Health*, vol. 65, No. 4, pp. 36-44 (1975).

Ledermann, et al., Long-Lasting Osseointegration of Immediately Loaded, Bar-Connected TPS Screws After 12 Years of Function: A Histologic Case Report of a 95-year-old Patient, *The International Journal of Periodontics & Restorative Dentistry*, 18(6):553-563 (1998).

Ledermann, et al., Titanium-Coated Screw Implants as Alloplastic Endosteal Retention Element in the Edentulous Problematic Mandible (I), Systematic Procedure to the Time of Impression-Taking, *Color Atlas, Quintessence International*, pp. 895-901 (1981).

M Implant—Double Morse Taper Connection, <http://en.tbr-implants.com/home/products/implants/implant-m>, 3 pages, Sep. 2014.

Spiekermann, et al., *Color Atlas of Dental Medicine, Implantology, Ledermann Screw Implant*, p. 52, (1995).

SwissPlus Implant System—Product Catalog, “Centerpulse”, 28 pages (2003).

Tapered SwissPlus Self-Tapping Design & Double Lead Threads, Zimmer Dental, http://www.zimmerdental.com/products/implants/im_tswpFSelfTap.aspx, 1 page, (2014).

Weiss, Charles M., DDS, *Principles and Practice of Implant Dentistry*, Chapter 19—Endodontic Stabilizer Implants-Tooth Root Extension For Improved Prognosis, 17 pages (2001).

International Search Report and Written Opinion dated Jan. 8, 2016 in Int'l PCT Patent Application Serial No. PCT/BR2015/050240.

* cited by examiner

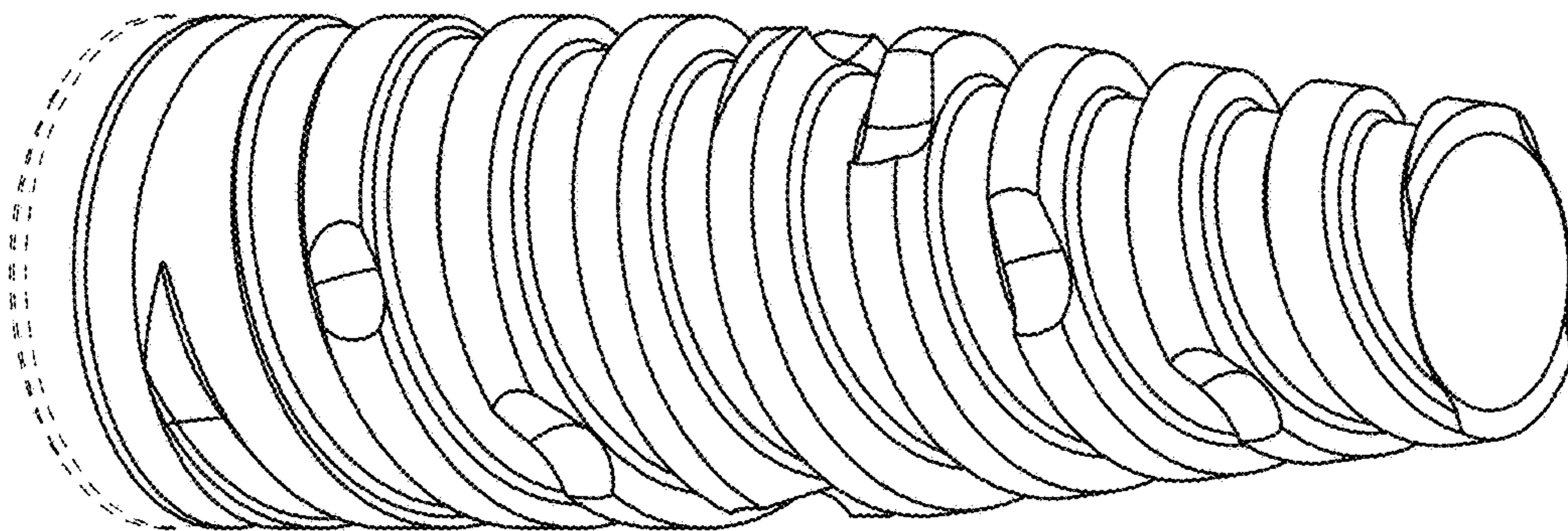

FIG. 1

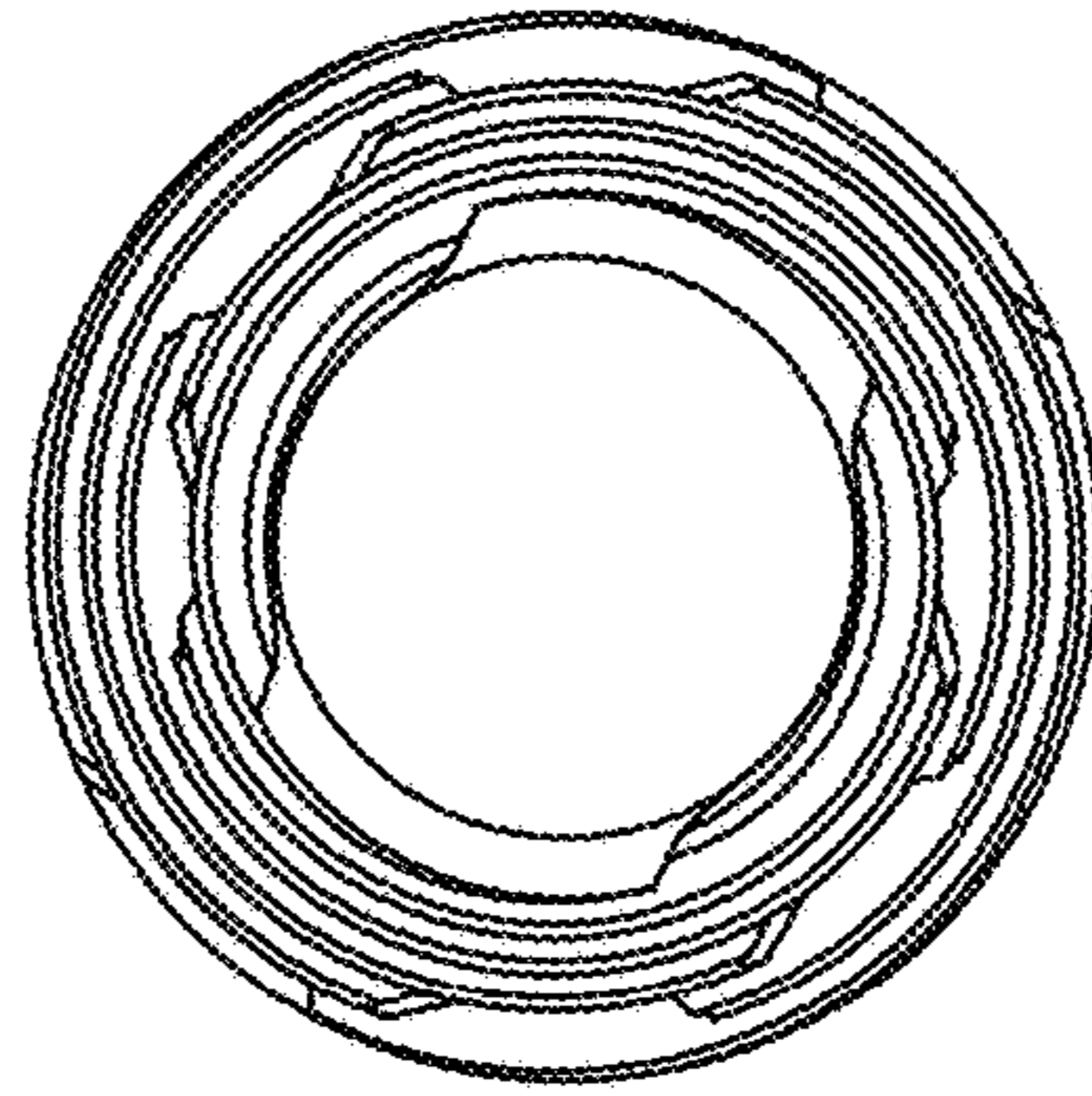

FIG. 2

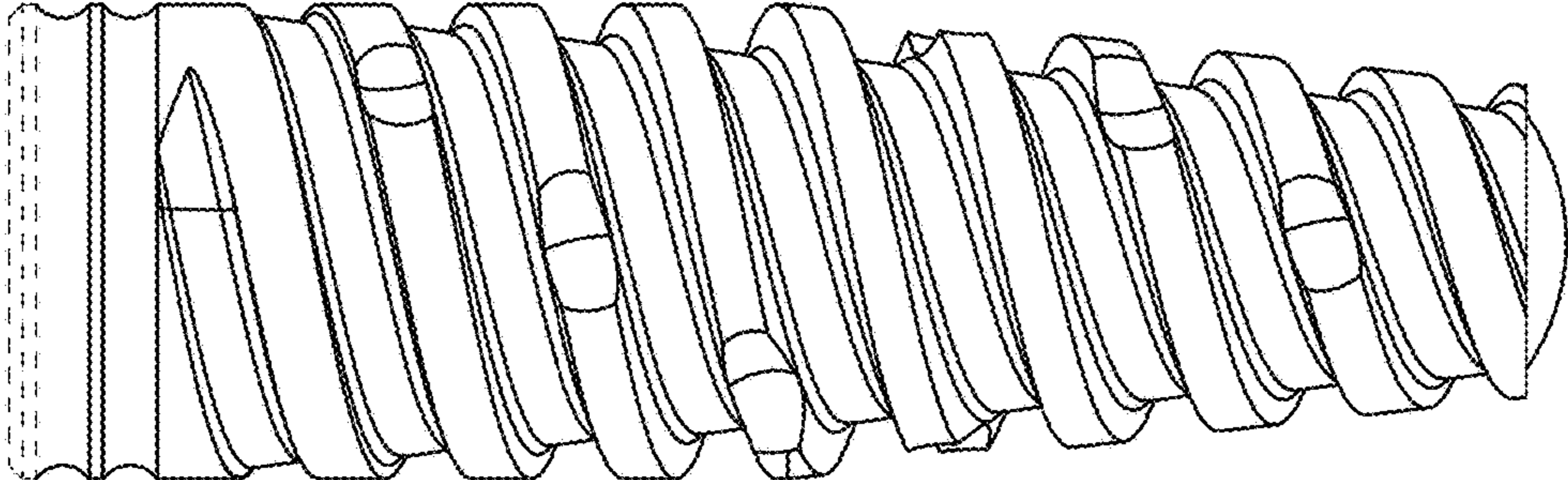

FIG. 4

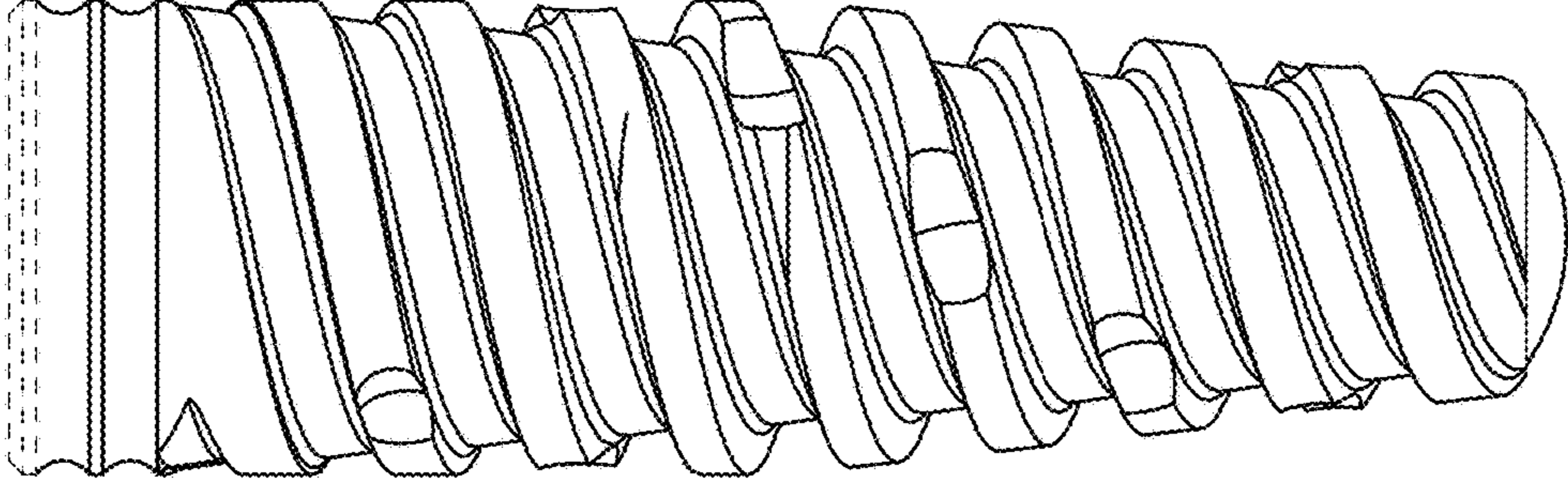

FIG. 3

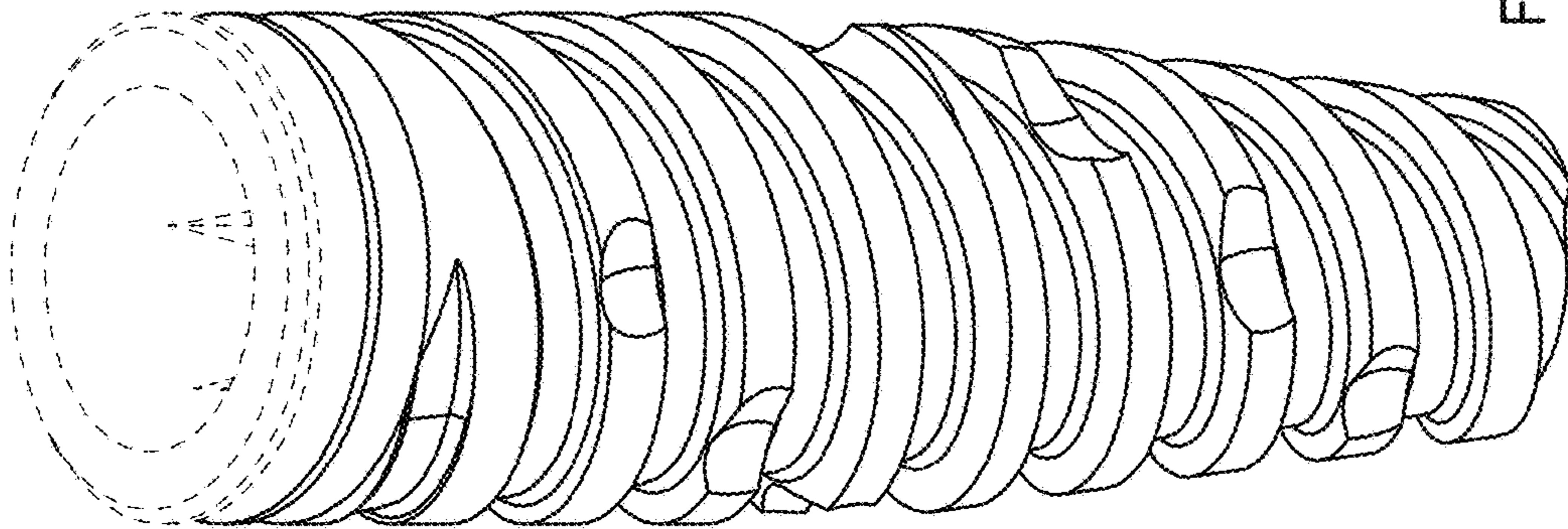

FIG. 5

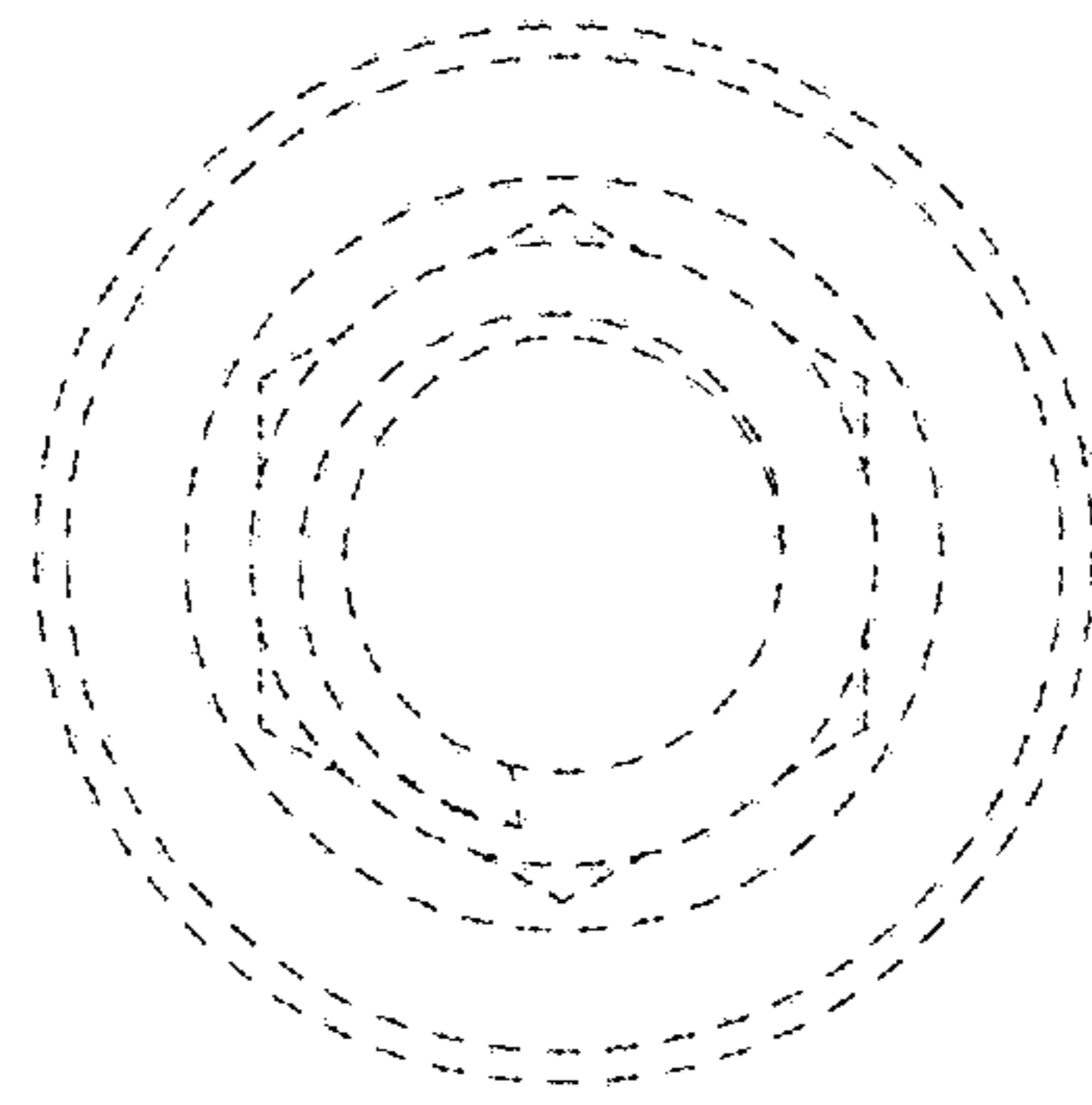

FIG. 6