



US00D816797S

(12) **United States Design Patent**  
**Lim**

(10) **Patent No.:** **US D816,797 S**

(45) **Date of Patent:** **\*\* May 1, 2018**

(54) **ALKALINE WATER IONIZER**  
(71) Applicant: **Lifecore Instrument Inc.**, Suwon-si (KR)  
(72) Inventor: **Dong Won Lim**, Seoul (KR)  
(73) Assignee: **LIFECORE INSTRUMENT INC.**, Gyeonggi-Do (KR)

D697,356 S \* 1/2014 Choi ..... D23/207  
D707,791 S \* 6/2014 Beghelli ..... D23/207  
D718,413 S \* 11/2014 Choi ..... D23/207  
D718,414 S \* 11/2014 Lo ..... D23/207  
D762,809 S \* 8/2016 Kim ..... D23/207  
D769,407 S \* 10/2016 Lee ..... D23/207  
D788,877 S \* 6/2017 Yoon ..... D23/207  
9,856,126 B2 \* 1/2018 Jeon ..... B67D 1/0859

\* cited by examiner

*Primary Examiner* — Robin V Webster

(74) *Attorney, Agent, or Firm* — Cantor Colburn LLP

(\*\*) Term: **15 Years**

(21) Appl. No.: **29/594,753**

(22) Filed: **Feb. 22, 2017**

(51) **LOC (11) Cl.** ..... **23-01**

(52) **U.S. Cl.**  
USPC ..... **D23/207**

(58) **Field of Classification Search**  
USPC ..... D23/200, 207, 209; 210/232, 282, 238, 210/87  
CPC .. B01D 35/143; B01D 35/30; B01D 19/0031; C02F 1/003; C02F 1/283  
See application file for complete search history.

(56) **References Cited**

**U.S. PATENT DOCUMENTS**

D669,154 S \* 10/2012 Choi ..... D23/207  
D683,421 S \* 5/2013 Choi ..... D23/207

(57) **CLAIM**

The ornamental design for an alkaline water ionizer, as shown and described.

**DESCRIPTION**

FIG. 1 is a perspective view of an alkaline water ionizer showing my new design;  
FIG. 2 is a front elevational view thereof;  
FIG. 3 is a rear elevational view thereof;  
FIG. 4 is a left side elevational view thereof;  
FIG. 5 is a right side elevational view thereof;  
FIG. 6 is a top plan view thereof; and,  
FIG. 7 is a bottom plan view thereof.

**1 Claim, 7 Drawing Sheets**

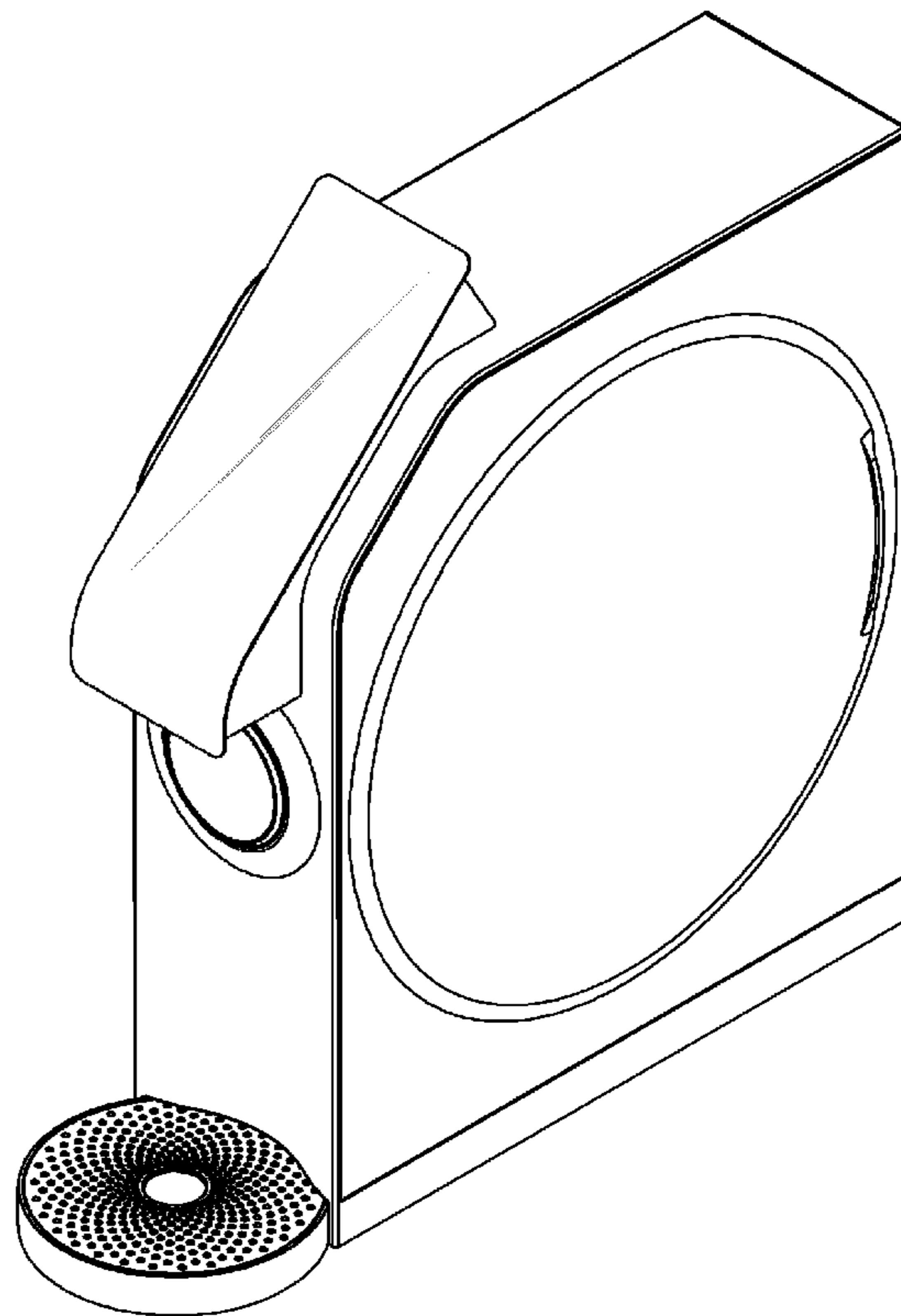

FIG. 1

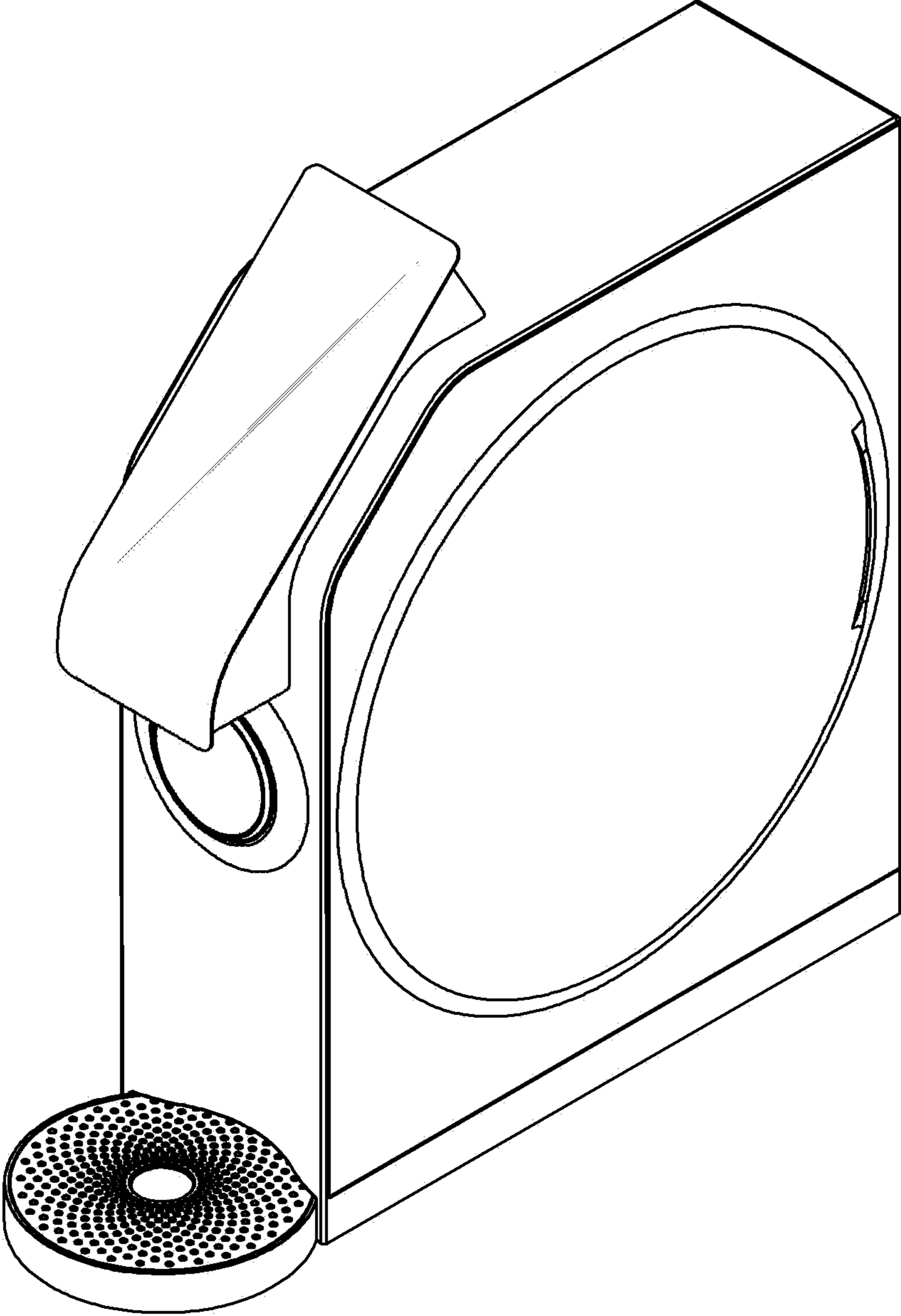

FIG. 2

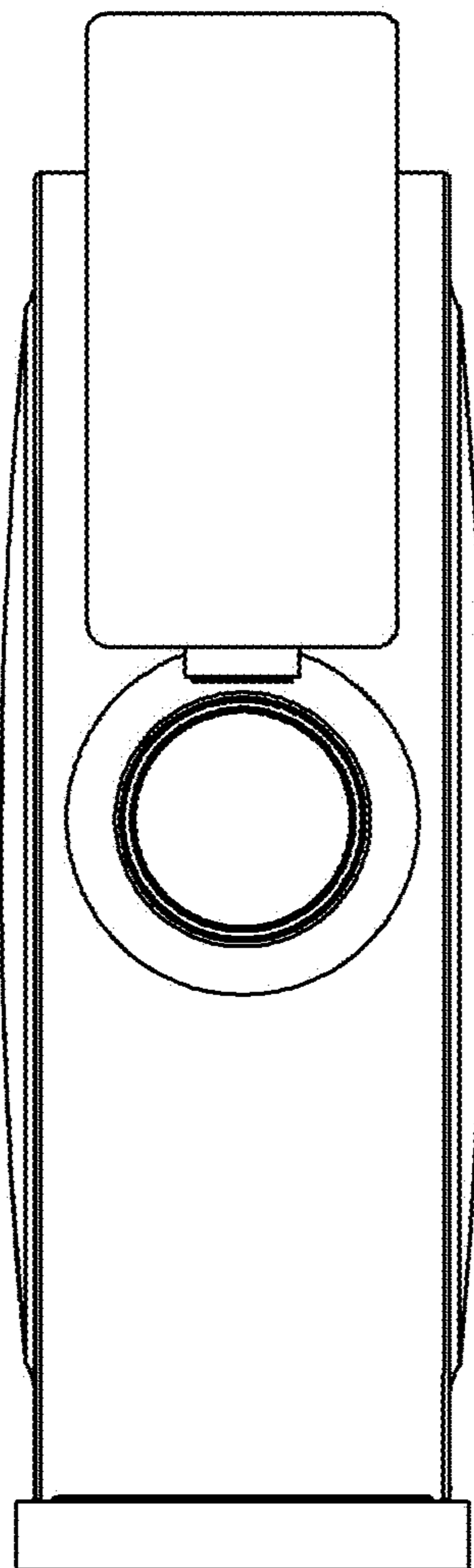

FIG. 3

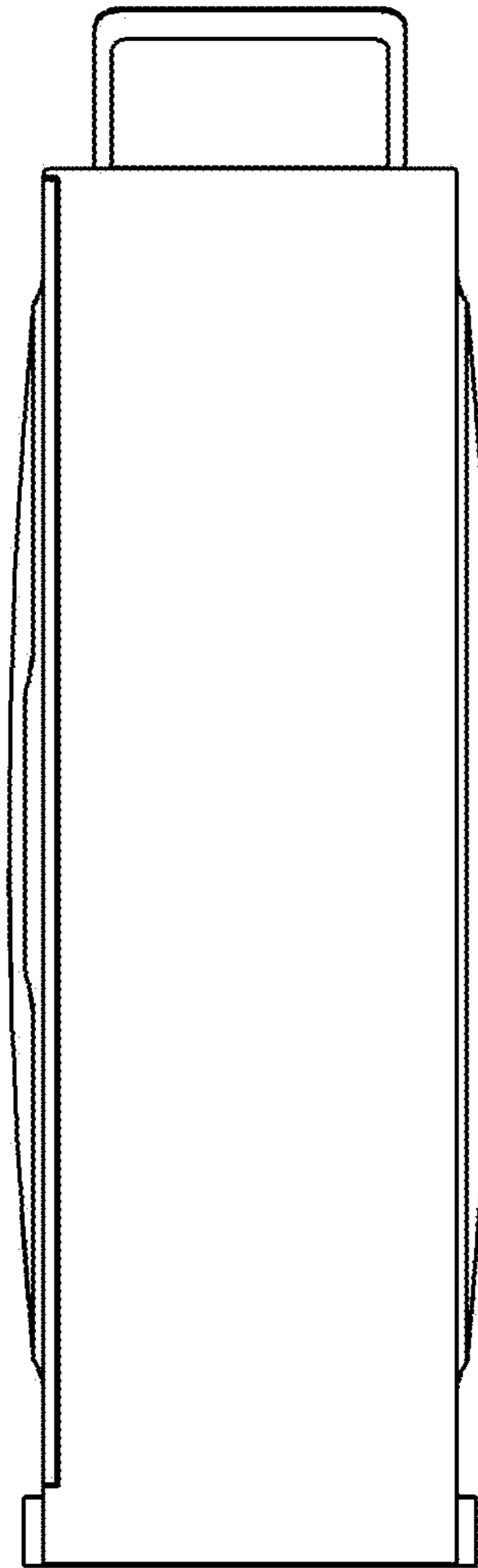

FIG. 4

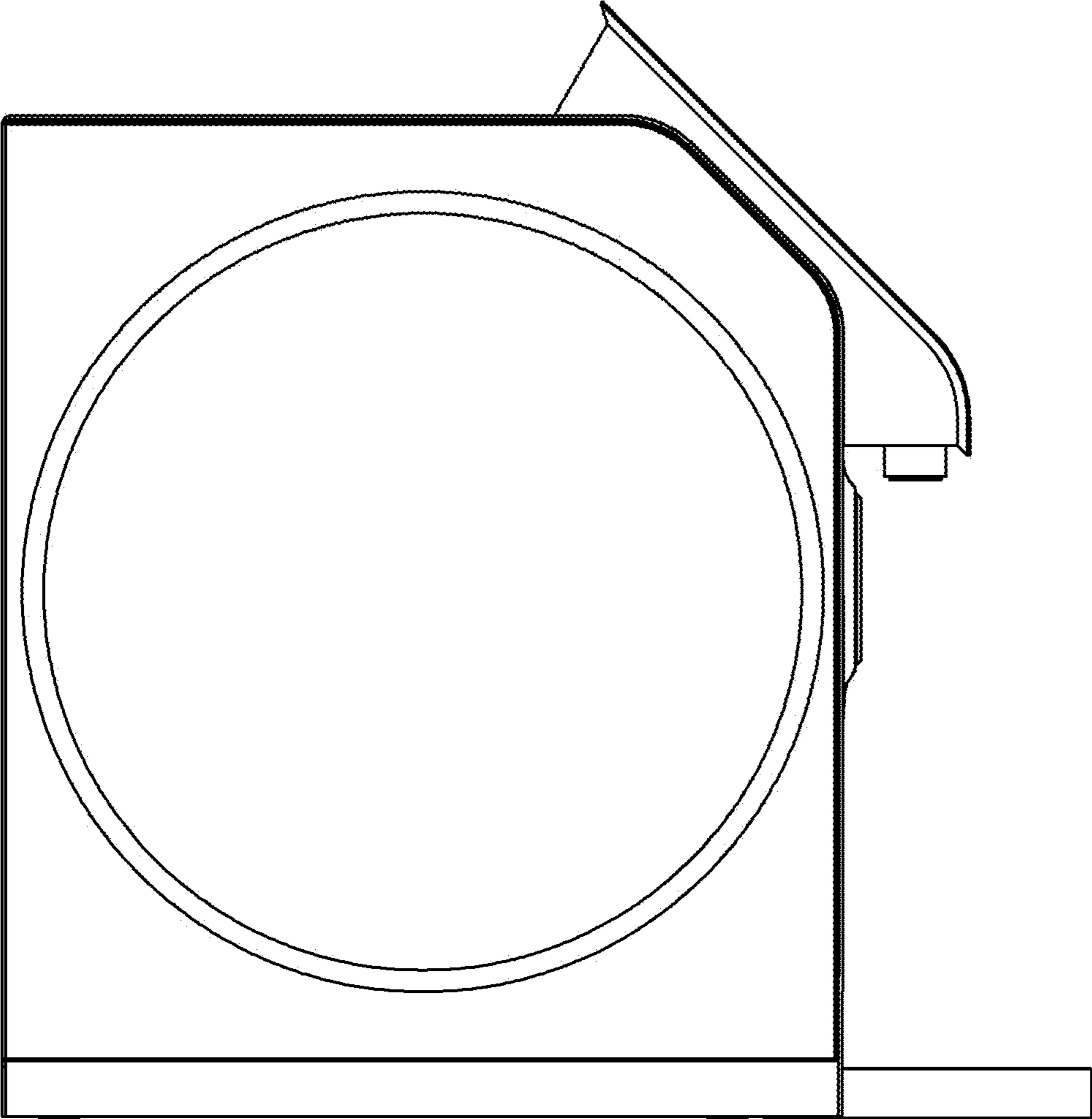

FIG. 5

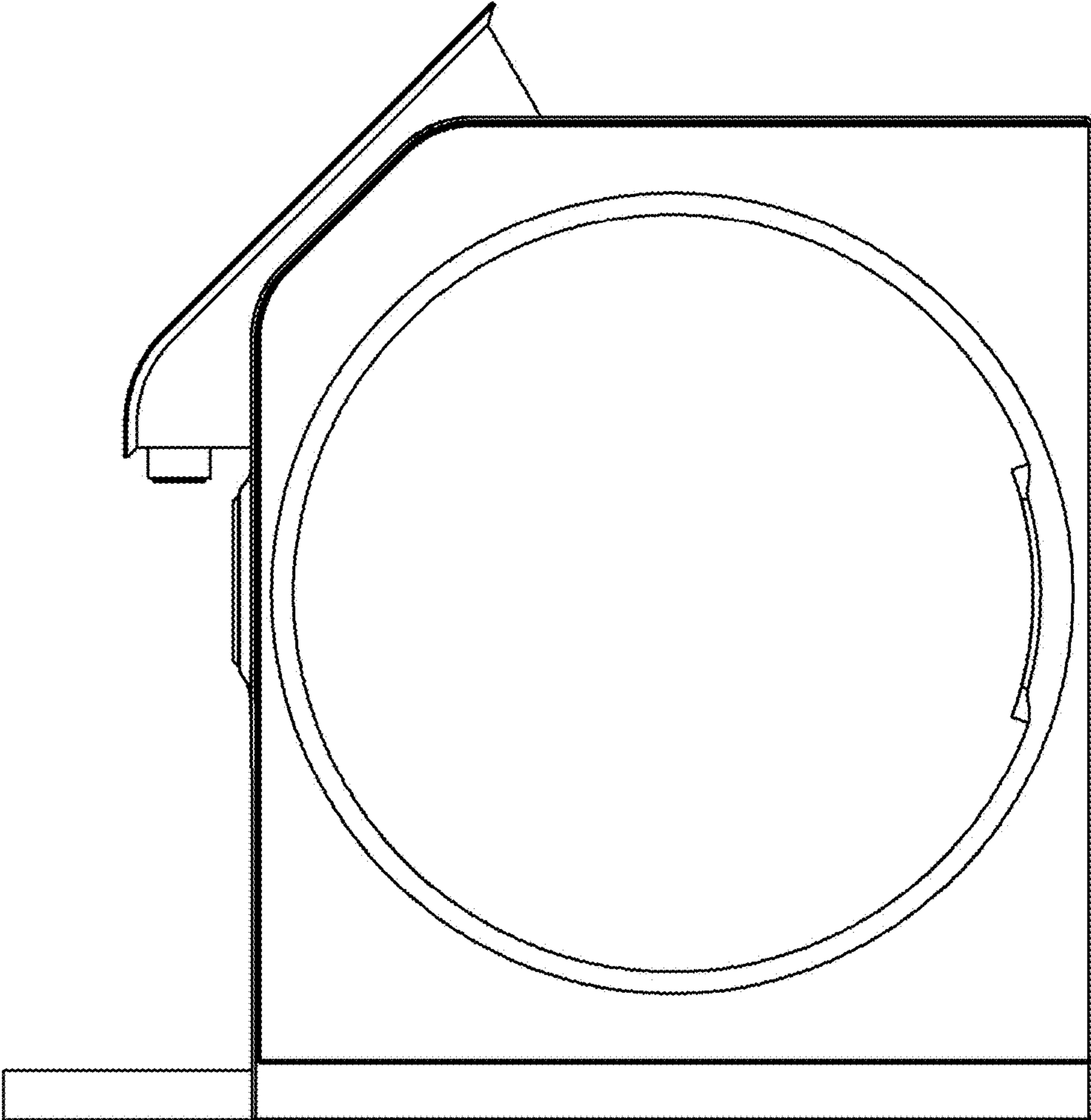

FIG. 6

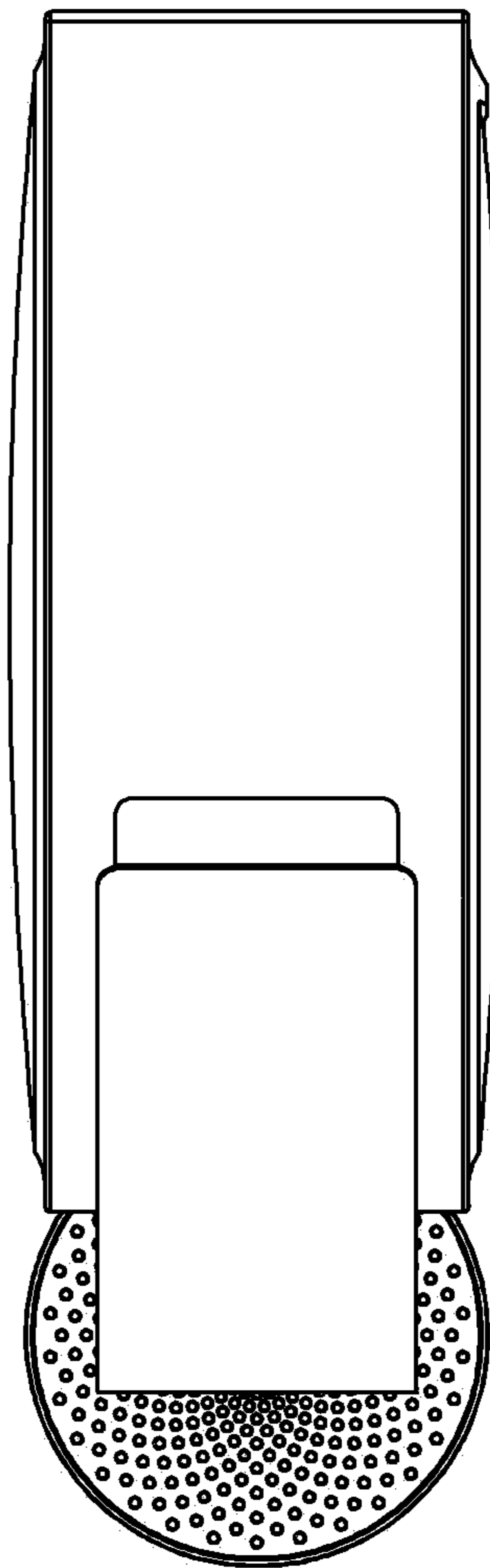

FIG. 7

