



US00D816762S

(12) **United States Design Patent** (10) **Patent No.:** **US D816,762 S**
Suzuki (45) **Date of Patent:** **** May 1, 2018**

(54) **GUITAR** 6,051,766 A * 4/2000 Taylor G10D 3/06
84/267
(71) Applicant: **YAMAHA CORPORATION,** D565,093 S * 3/2008 Chan D17/14
Hamamatsu-shi (JP) D768,762 S * 10/2016 Kamijo D17/14
2017/0206881 A1 * 7/2017 Ekuni G10H 3/146

(72) Inventor: **Toshihide Suzuki,** Hamamatsu-shi (JP)

FOREIGN PATENT DOCUMENTS

(73) Assignee: **YAMAHA CORPORATION,**
Hamamatsu-shi (JP)

CN 3027733 * 12/1993
WO WO-2014167272 A2 * 10/2014 G10D 1/08

(**) Term: **15 Years**

OTHER PUBLICATIONS

(21) Appl. No.: **29/571,334**

Yamaha, A Series Electric Acoustic Guitars, production year of 2011, [online], [site visited on Aug. 25, 2017]. Available from Internet, URL: https://www.yamaha.com/en/about/design/synapses/id_048/.*

(22) Filed: **Jul. 18, 2016**

(30) **Foreign Application Priority Data**

(Continued)

Jan. 19, 2016 (JP) 2016-000857

(51) **LOC (11) Cl.** **17-03**

Primary Examiner — Sheryl Lane

(52) **U.S. Cl.**
USPC **D17/14**

Assistant Examiner — Samantha Wood

(58) **Field of Classification Search**
USPC D17/14–21, 99; D21/324
CPC G10D 1/00; G10D 1/08; G10D 1/085;
G10D 3/00; G10D 3/06; G10D 3/12;
G10D 3/02; G10H 3/00; G10H 3/18;
G10H 3/181

(74) *Attorney, Agent, or Firm* — Sughrue Mion, PLLC

See application file for complete search history.

(57)

CLAIM

(56) **References Cited**

The ornamental design for a guitar, as shown and described.

U.S. PATENT DOCUMENTS

DESCRIPTION

D83,426 S * 2/1931 Bremerman D17/19
D242,074 S * 10/1976 Kasha D17/19
D254,621 S * 4/1980 Bolen D17/19
D270,735 S * 9/1983 McPherson, Sr. D17/19
D280,521 S * 9/1985 Wechter D17/14
5,796,021 A * 8/1998 Longshore G10D 3/163
84/329
D407,430 S * 3/1999 Rosenberg D17/20

FIG. 1 is a front view of a guitar showing my new design;
FIG. 2 is a rear view thereof;
FIG. 3 is a left side view thereof;
FIG. 4 is a right side view thereof;
FIG. 5 is a top plan view thereof;
FIG. 6 is a bottom plan view thereof;
FIG. 7 is an enlarged view at line 7 in FIG. 3; and,
FIG. 8 is an enlarged view at line 8 in FIG. 6.
The portions of the guitar shown in broken lines form no part of the claimed design.

1 Claim, 6 Drawing Sheets

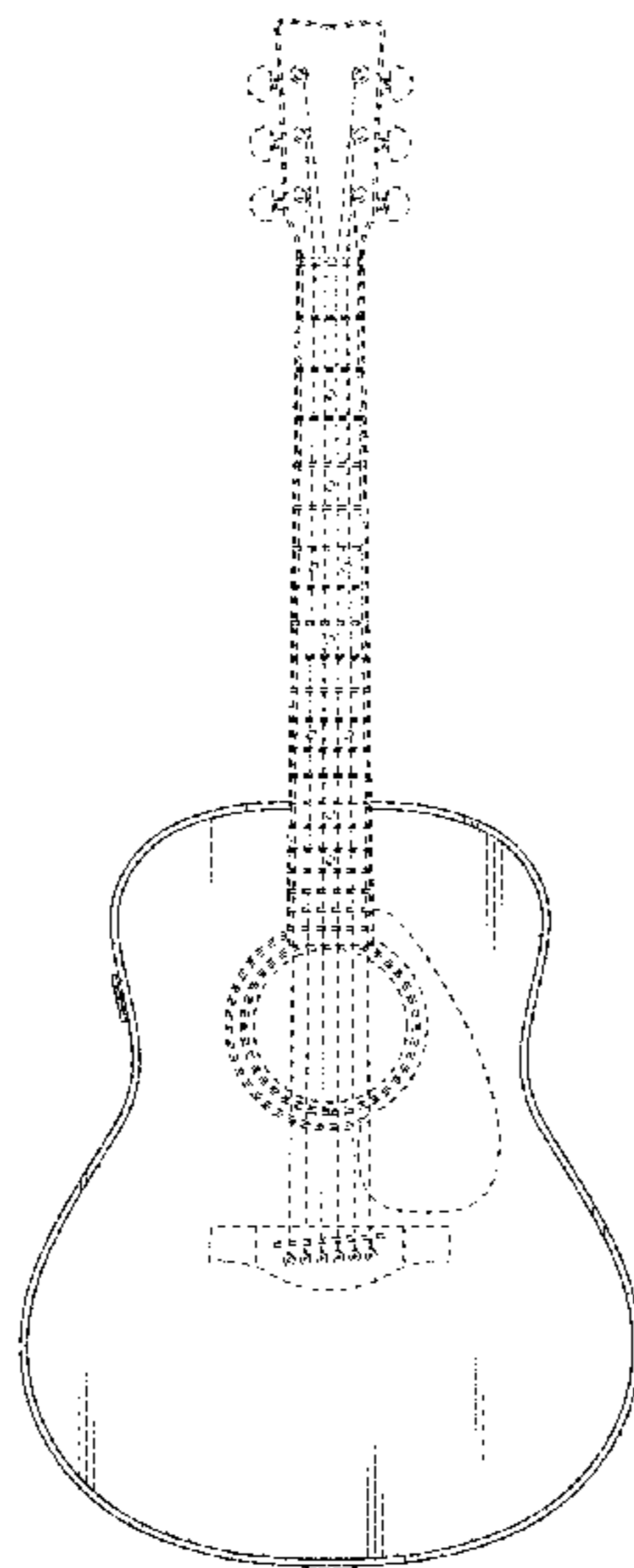

(56)

References Cited

OTHER PUBLICATIONS

Amazon, Seagull Artist Mosaic QII Acoustic Electric Guitar, first available Jan. 1, 2010, [online], [site visited on Aug. 25, 2017]. Available from Internet, URL: <https://www.amazon.com/Seagull-Artist-Mosaic-Acoustic-Electric/dp/B003C80SDQ>.*

Sweetwater, Seagull Guitars S6 Original Q1—Natural, customer review on Nov. 29, 2014, [online], [site visited on Aug. 25, 2017]. Available from Internet, URL: <https://www.sweetwater.com/store/detail/OSS6Q1>.*

Amazon, Stagg Acoustic-Electric Guitar, first available Jul. 25, 2008, [online], [site visited on Dec. 19, 2017]. Available from Internet, URL: <https://www.amazon.com/Stagg-Full-Size-Classical-Cutaway-Acoustic-Electric/dp/B001D8I9PG> (Year: 2008).*

Learn to Play Music, All About the Electric Acoustic Guitar, posted on Oct. 9, 2014, [online], [site visited on Dec. 19, 2017]. Available from Internet, URL: <http://www.learntoplaymusic.com/blog/electric-acoustic-guitar/> (Year: 2014).*

Musician's Workshop, Taylor Expression System 2, posted on Jan. 11, 2014, [online], [site visited on Dec. 19, 2017]. Available from Internet, URL: <https://musiciansworkshop.com/news/taylor-expression-system-2> (Year: 2014).*

* cited by examiner

Fig. 1

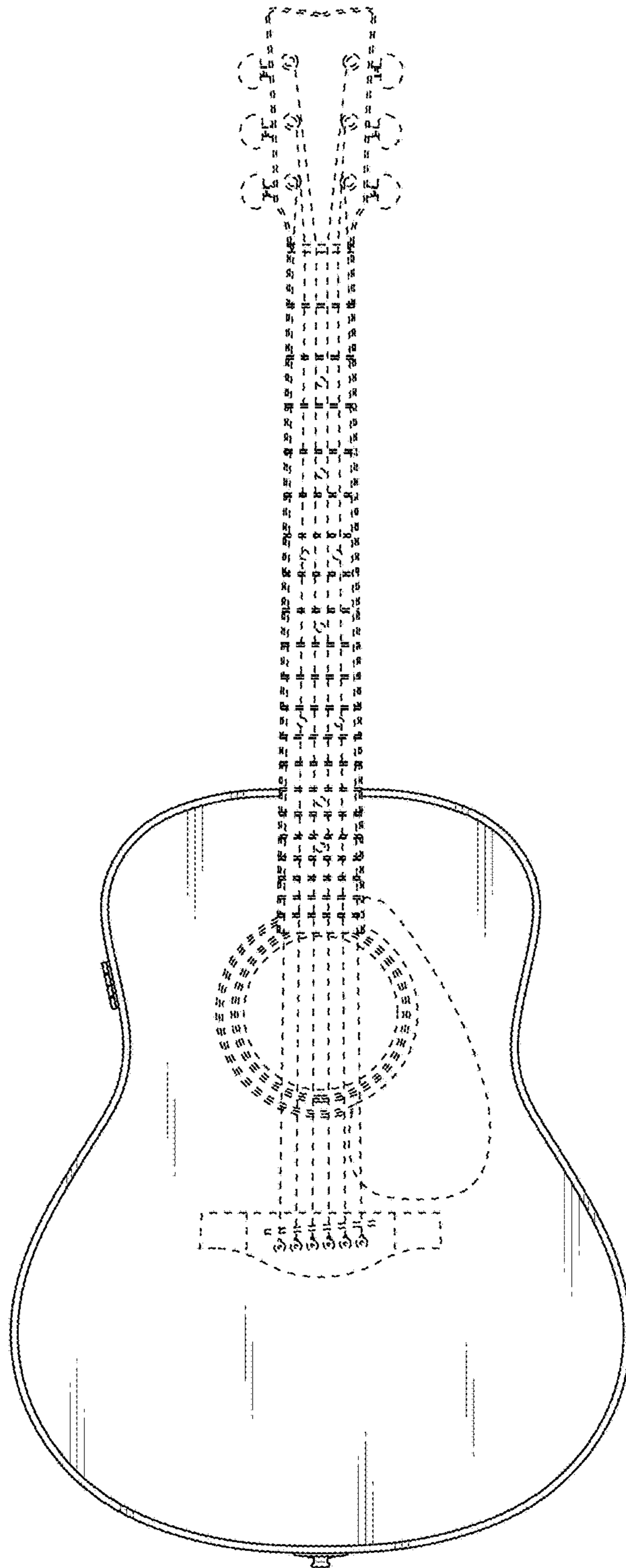

Fig. 2

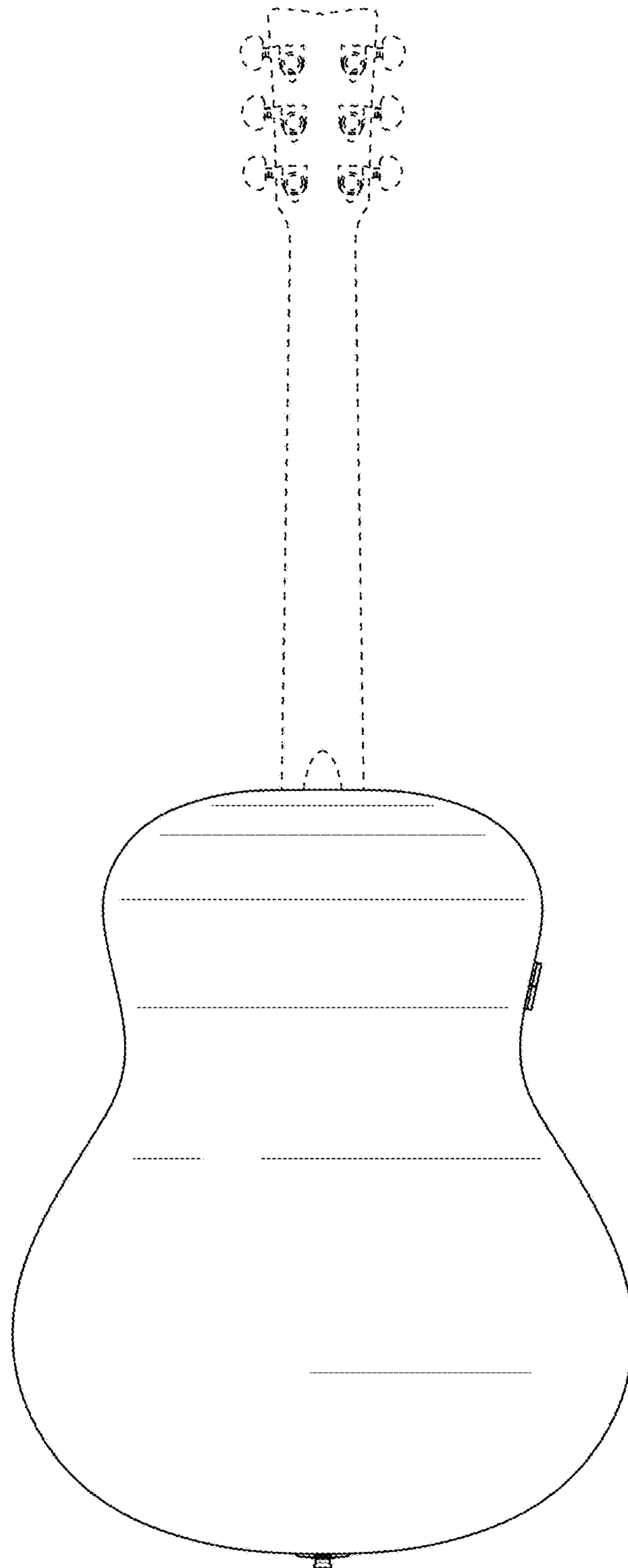

Fig. 3

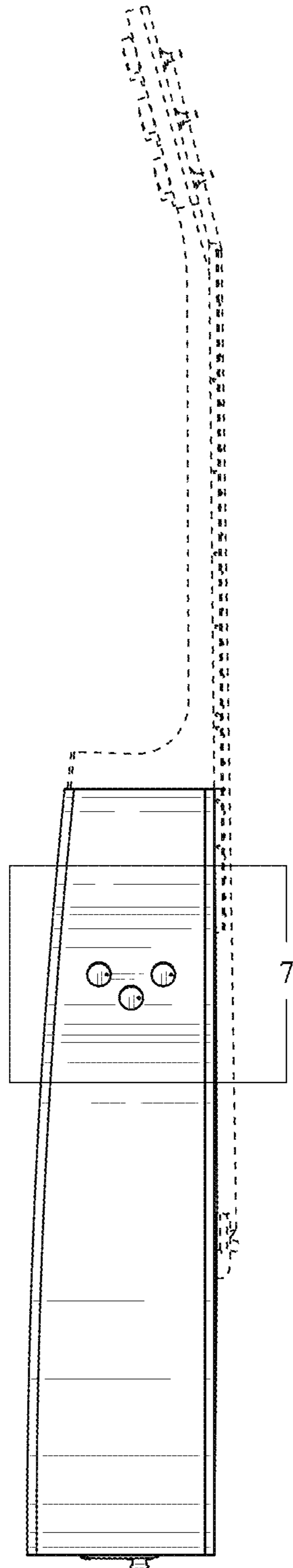

Fig. 4

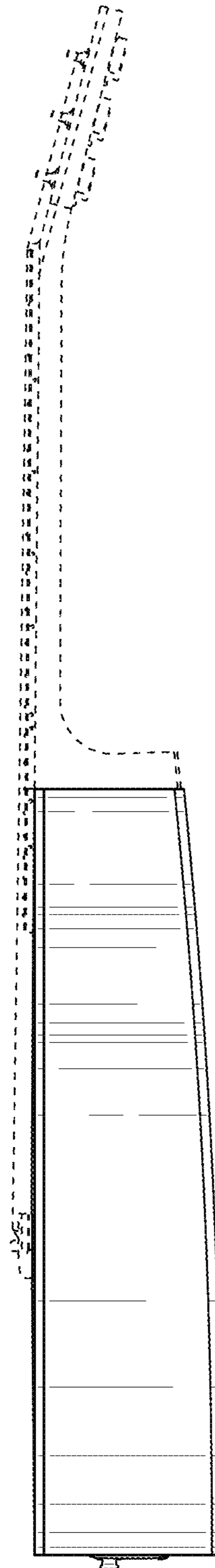

Fig. 5

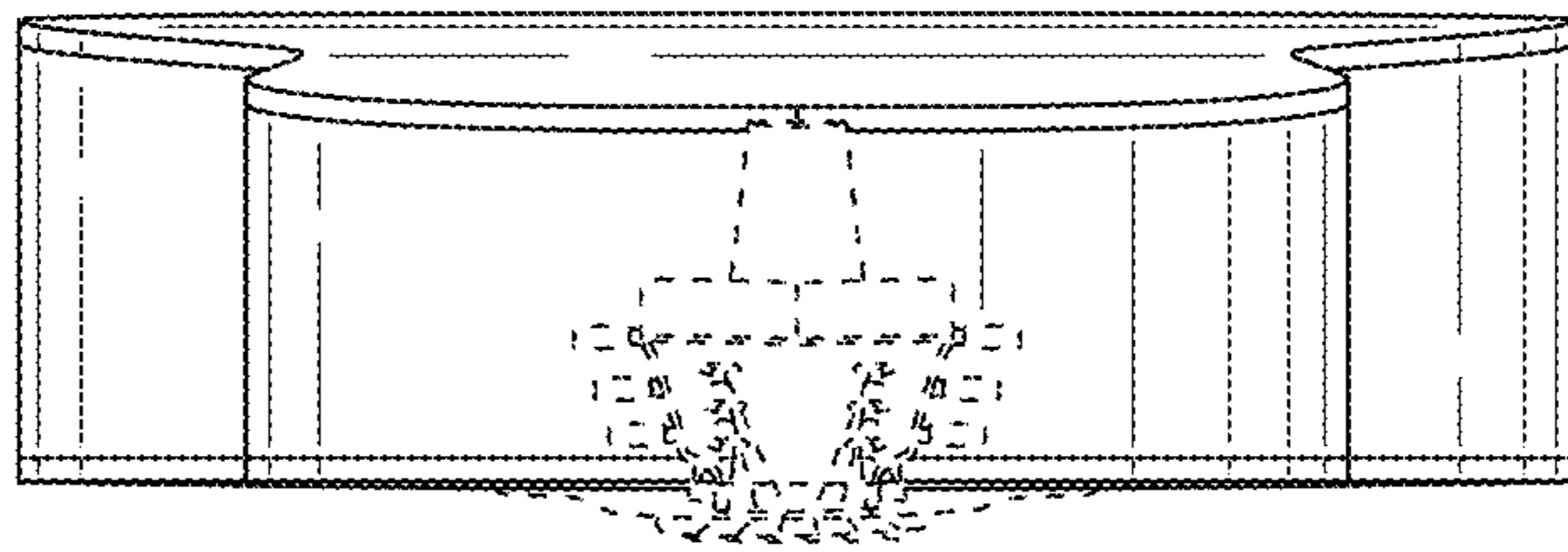

Fig. 6

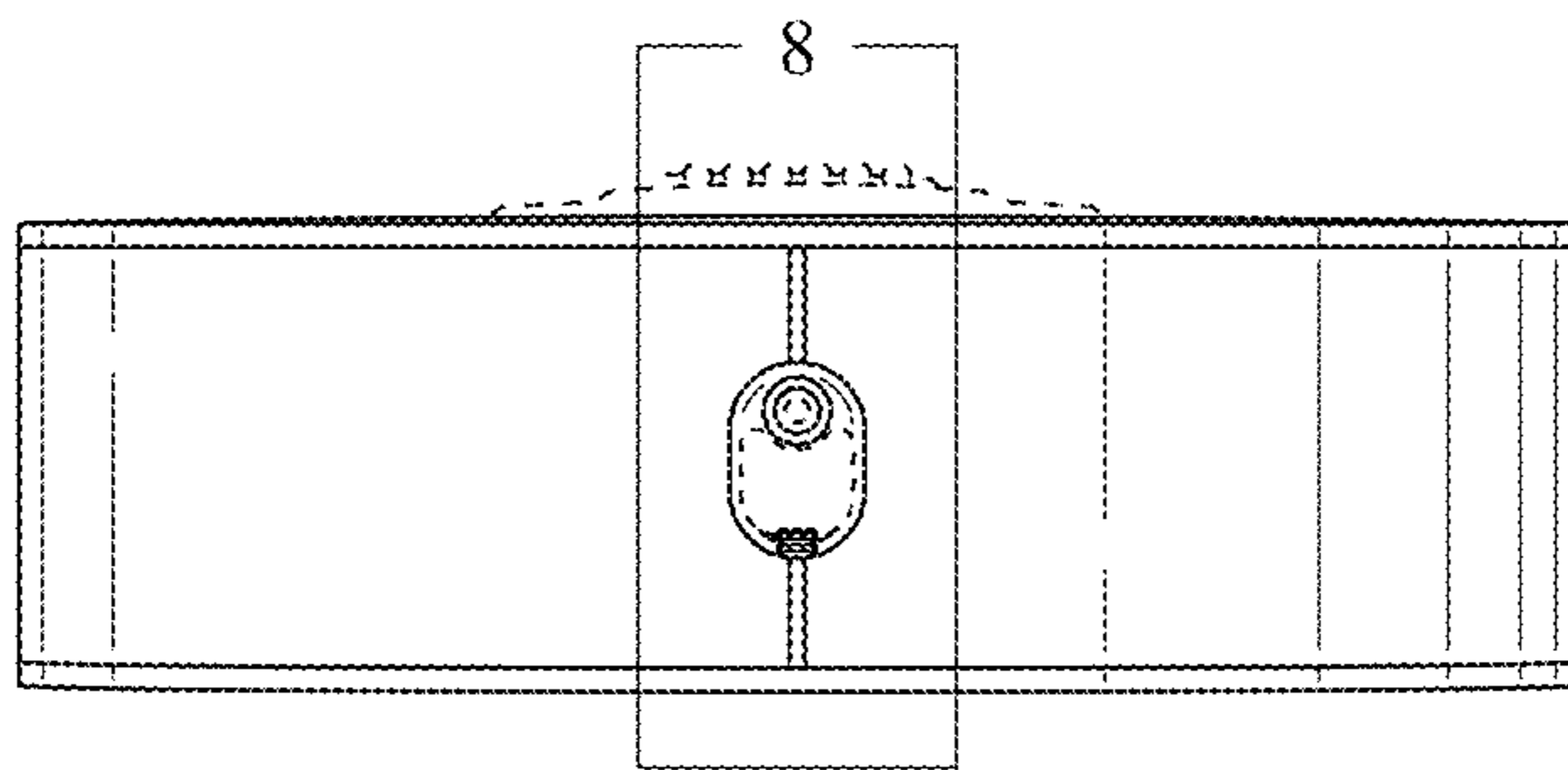

Fig. 7

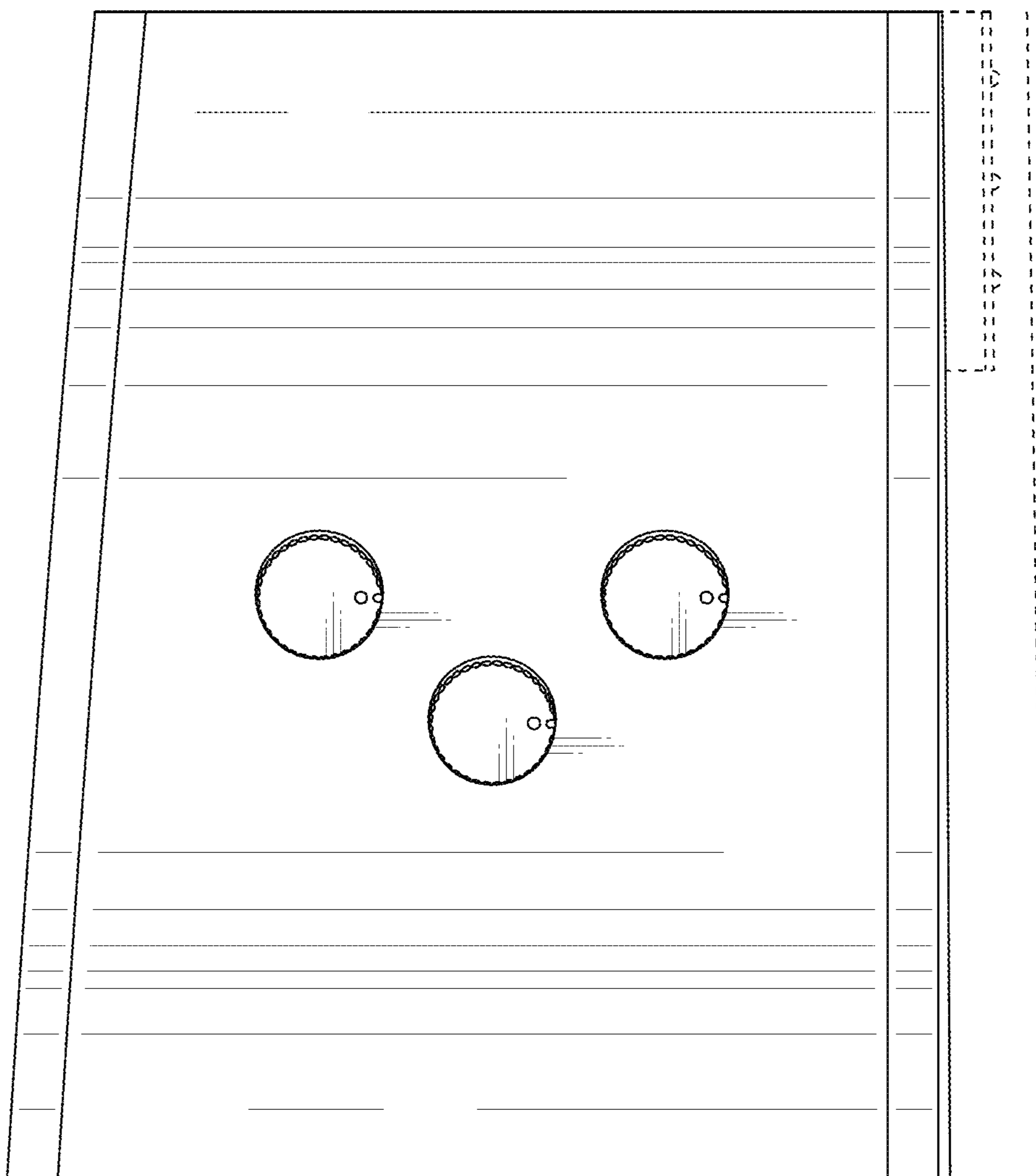

Fig. 8

