



US00D816601S

(12) **United States Design Patent** (10) **Patent No.:** **US D816,601 S**
Matsumoto (45) **Date of Patent:** **** May 1, 2018**

(54) **SPIKE PIN FOR AUTOMOBILE TIRE**
(71) Applicant: **THE YOKOHAMA RUBBER CO., LTD.**, Minato-ku, Tokyo (JP)
(72) Inventor: **Kenichi Matsumoto**, Hiratsuka (JP)
(73) Assignee: **THE YOKOHAMA RUBBER CO., LTD.**, Minato-ku, Tokyo (JP)

(**) Term: **15 Years**
(21) Appl. No.: **29/569,169**
(22) Filed: **Jun. 24, 2016**

(30) **Foreign Application Priority Data**
Dec. 25, 2015 (JP) 2015-028890
(51) **LOC (11) Cl.** **12-15**
(52) **U.S. Cl.**
USPC **D12/608**
(58) **Field of Classification Search**
USPC D12/500, 501, 544, 579, 604-608;
152/210-212, 243; 156/144; 301/41.1,
301/42, 43, 44.3; 305/19, 187, 189, 191
CPC B60C 27/08; B60C 11/16; B60C 11/165;
B60C 11/1625; B60C 11/1637; B60C
11/1643; B60C 11/1656; B60C 11/1675;
B60C 11/1693
See application file for complete search history.

(56) **References Cited**
U.S. PATENT DOCUMENTS
D431,215 S * 9/2000 Nyblom D12/608
D550,611 S * 9/2007 Liukkula D12/608
D551,614 S * 9/2007 Liukkula D12/608
D559,775 S * 1/2008 Liukkula D12/608
D584,979 S * 1/2009 Pirhonen D12/608
D608,233 S * 1/2010 Pirhonen D12/608
D609,127 S * 2/2010 Pirhonen D12/608

D706,709 S * 6/2014 Matsumoto D12/608
D708,567 S * 7/2014 Matsumoto D12/608
D774,449 S * 12/2016 Matsumoto D12/608
D775,585 S * 1/2017 Matsumoto D12/608
D775,586 S * 1/2017 Matsumoto D12/608
D776,047 S * 1/2017 Matsumoto D12/608
D776,048 S * 1/2017 Matsumoto D12/608
D776,049 S * 1/2017 Matsumoto D12/608

(Continued)
Primary Examiner — Wan Laymon
Assistant Examiner — Clint A Samuel
(74) *Attorney, Agent, or Firm* — Banner & Witcoff, Ltd.

(57) **CLAIM**
The ornamental design for a spike pin for automobile tire, as shown and described.

DESCRIPTION
FIG. 1 is a perspective view of a spike pin for an automobile tire showing my new design;
FIG. 2 is a front view thereof;
FIG. 3 is a right side view thereof;
FIG. 4 is a top view thereof;
FIG. 5 is a bottom view thereof;
FIG. 6 is a cross sectional view taken along lines 6-6 shown in FIG. 2; and,
FIG. 7 is a cross sectional view taken along lines 7-7 shown in FIG. 3.
The dash-dot-dashed styled broken lines in FIGS. 6 and 7 represent the internal portion of the spike pin and form no part of the claimed design. The even length broken lines depict environmental subject matter only and form no part of the claimed design. The dot and dashed lines represents a boundary between the claimed portion and the non-claimed portion.
A rear view appears to be identical to the front view and is omitted. A left side view appears to be identical to the right side view and is omitted. The thin lines shown in the views are for clarifying the shape of the three-dimensional surface.

1 Claim, 7 Drawing Sheets

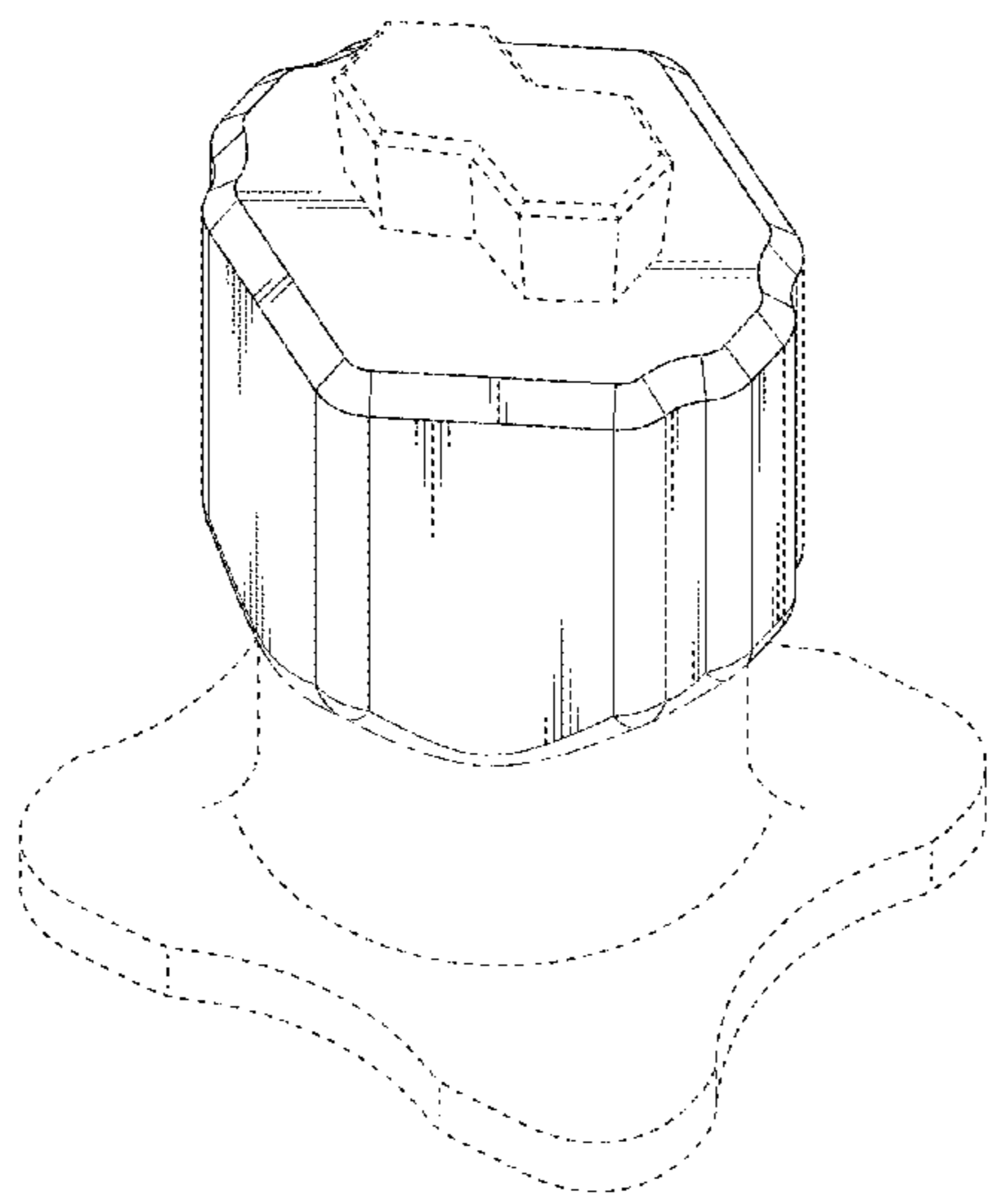

(56)

References Cited

U.S. PATENT DOCUMENTS

D777,097	S *	1/2017	Matsumoto	D12/608
D790,448	S *	6/2017	Yoon	D12/605
D790,449	S *	6/2017	Yoon	D12/605
D792,841	S *	7/2017	Yoon	D12/605
2004/0079461	A1 *	4/2004	Salakari	B60C 11/165 152/210
2013/0000807	A1 *	1/2013	Pons	B60C 11/1643 152/210

* cited by examiner

FIG. 1

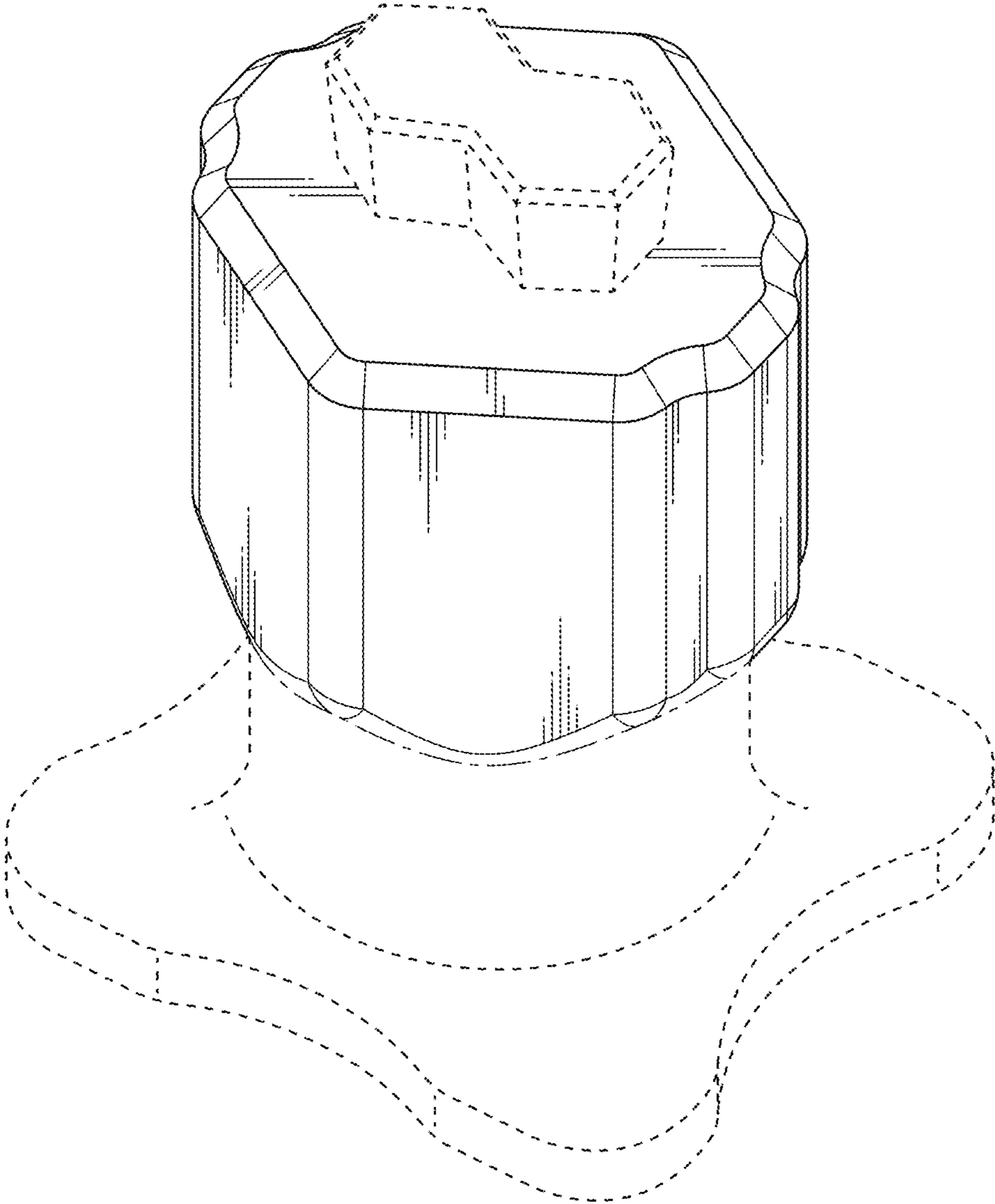

FIG. 2

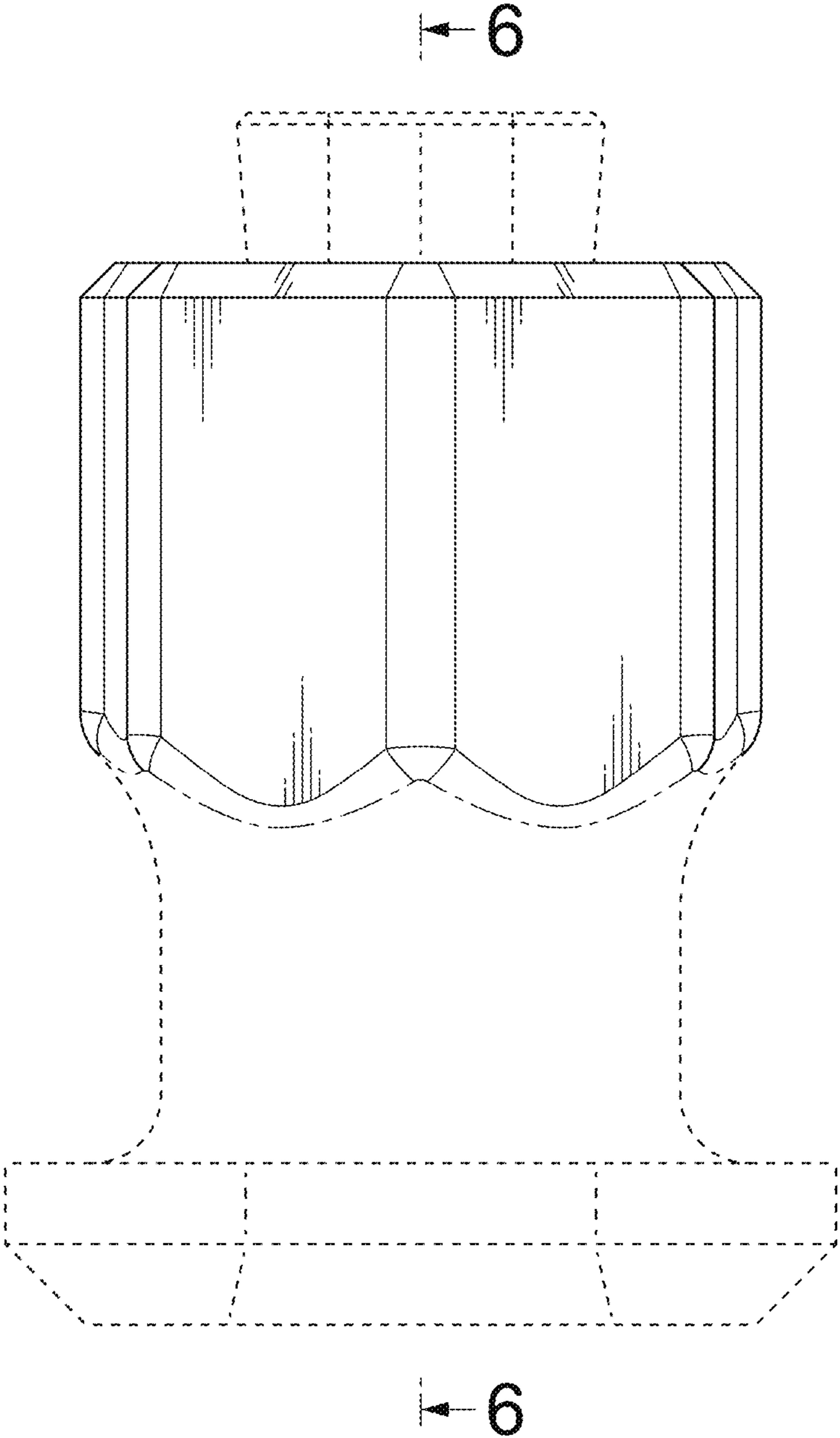

FIG. 3

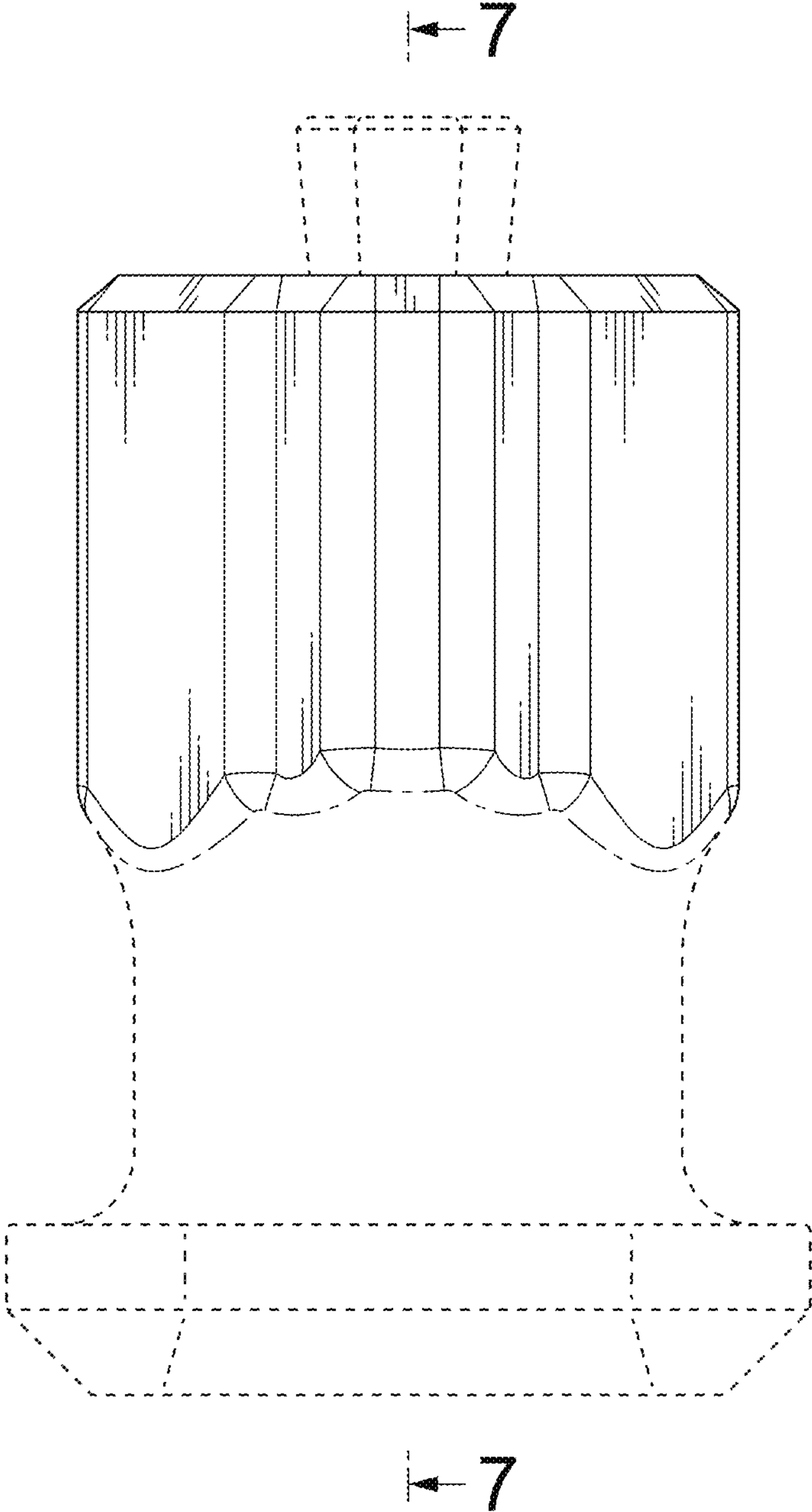

FIG. 4

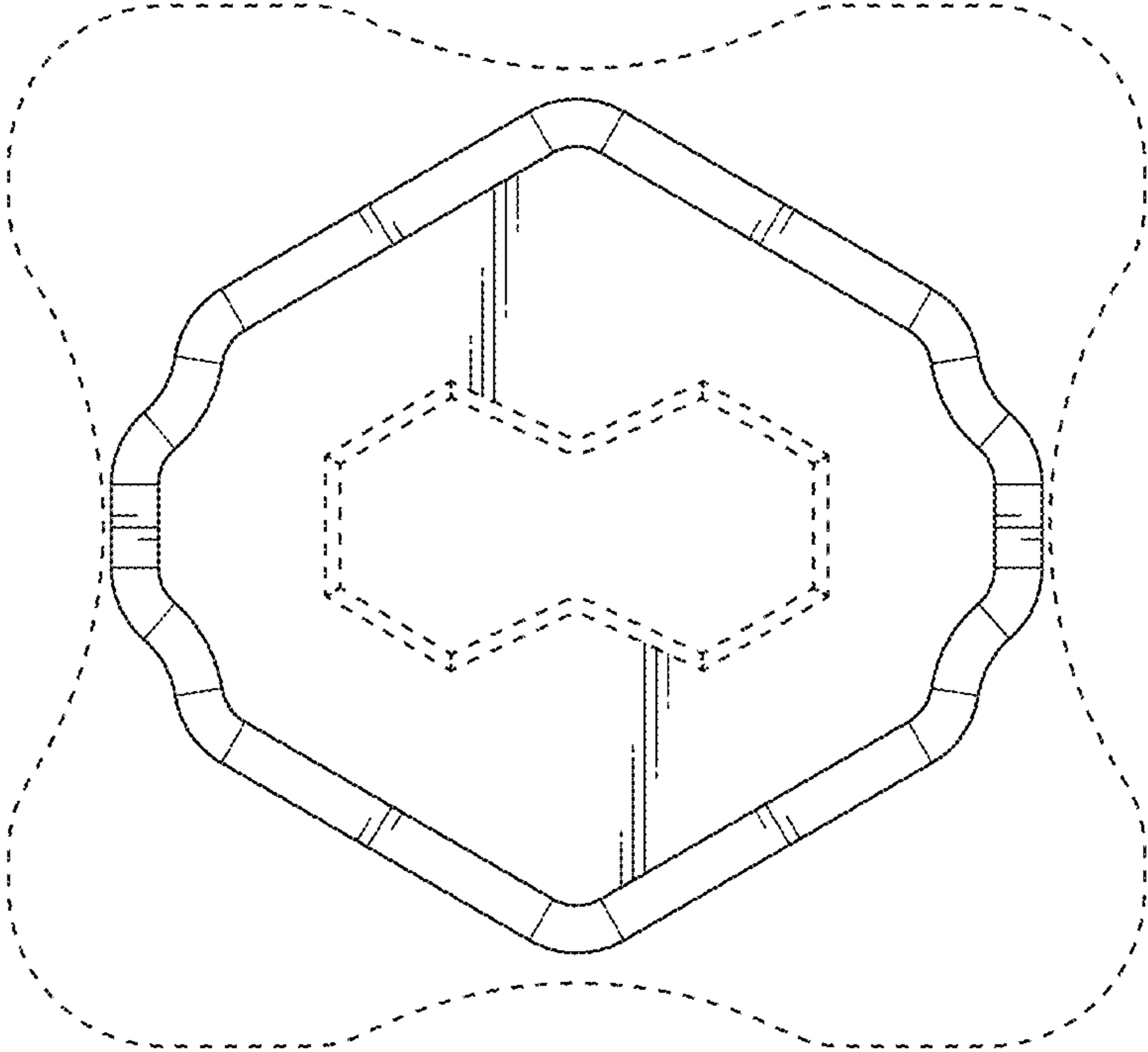

FIG. 5

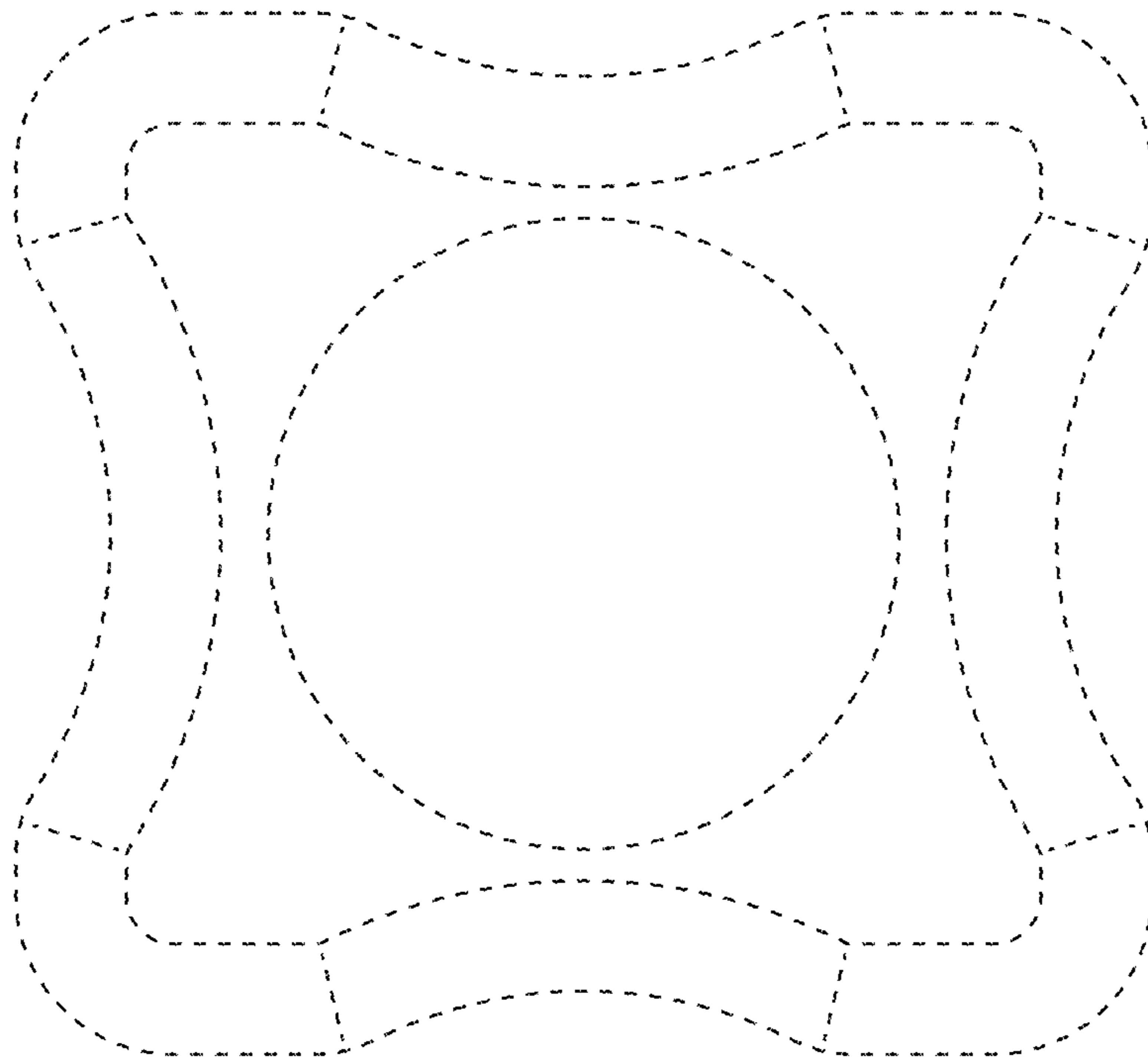

FIG. 6

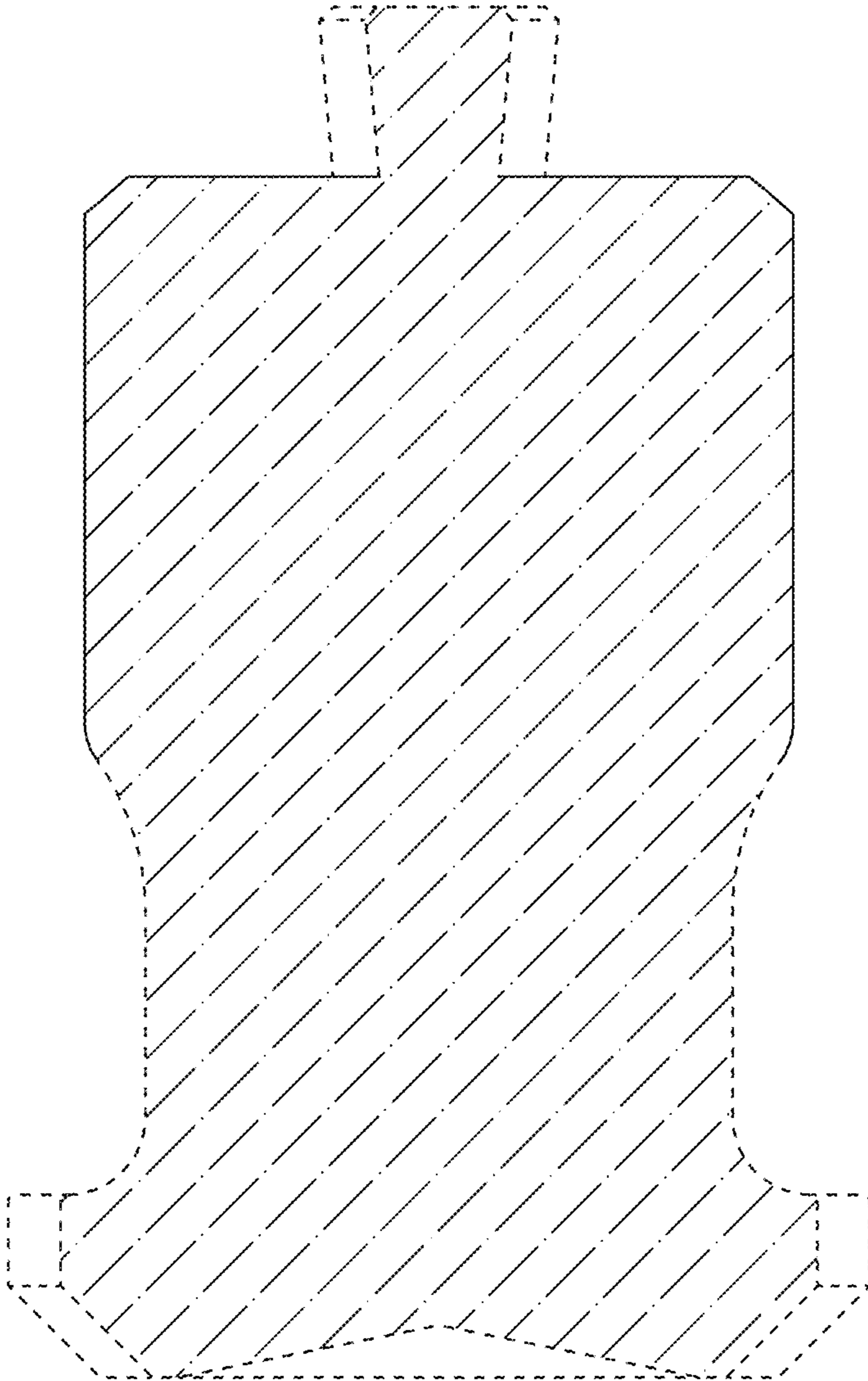

FIG. 7

