



US00D816557S

(12) **United States Design Patent** (10) **Patent No.:** **US D816,557 S**
Impero (45) **Date of Patent:** **** *May 1, 2018**

(54) **BUMPER FOR VEHICLE** 7,163,241 B2 1/2007 Liu et al.
7,163,242 B2 1/2007 Shuler et al.
(71) Applicant: **Industry A.M.S. S.r.l.**, Casalnuovo di 7,618,082 B2 11/2009 Tamada
Napoli (NA) (IT) 8,061,034 B2* 11/2011 Mellis B21D 5/08
29/897.2
(72) Inventor: **Pasquale Impero**, Casalnuovo di 8,061,743 B2* 11/2011 Wakabayashi B60R 19/18
Napoli (IT) 293/102
8,276,955 B2* 10/2012 Baccouche B60R 19/34
293/133
(73) Assignee: **INDUSTRY A.M.S. S.R.L.**, D704,606 S 5/2014 Kirtland
Casalnuovo di Napoli (IT) D731,934 S * 6/2015 Impero D12/172
9,238,444 B2* 1/2016 Terada B60R 19/18
D763,745 S * 8/2016 Lee, IV D12/169
(*) Notice: This patent is subject to a terminal dis- 2006/0071486 A1 4/2006 Lamparter
claimer. 2008/0284183 A1 11/2008 Johnson
(**) Term: **14 Years** * cited by examiner

(21) Appl. No.: **29/515,483**

(22) Filed: **Jan. 23, 2015**

Related U.S. Application Data

(62) Division of application No. 29/406,697, filed on Nov. 17, 2011, now Pat. No. Des. 731,934.

(30) **Foreign Application Priority Data**

May 18, 2011 (EM) 1865106-0001/0009

(51) **LOC (11) Cl.** **12-16**

(52) **U.S. Cl.**
USPC **D12/169**

(58) **Field of Classification Search**
USPC D12/169
CPC B21D 5/08
See application file for complete search history.

(56) **References Cited**

U.S. PATENT DOCUMENTS

3,831,441 A 8/1974 Petty
6,896,303 B1 5/2005 Mohr

Primary Examiner — George D Kirschbaum
(74) *Attorney, Agent, or Firm* — R. Neil Sudol; Henry D. Coleman

(57) **CLAIM**

I claim the ornamental design for bumper for vehicle, as shown and described.

DESCRIPTION

FIG. 1 is a front perspective of a bumper for vehicle showing my design;
FIG. 2 is a right side view thereof;
FIG. 3 is a left side view thereof;
FIG. 4 is a front view thereof;
FIG. 5 is a rear view thereof;
FIG. 6 is a top view thereof; and,
FIG. 7 is a bottom view thereof.

1 Claim, 3 Drawing Sheets

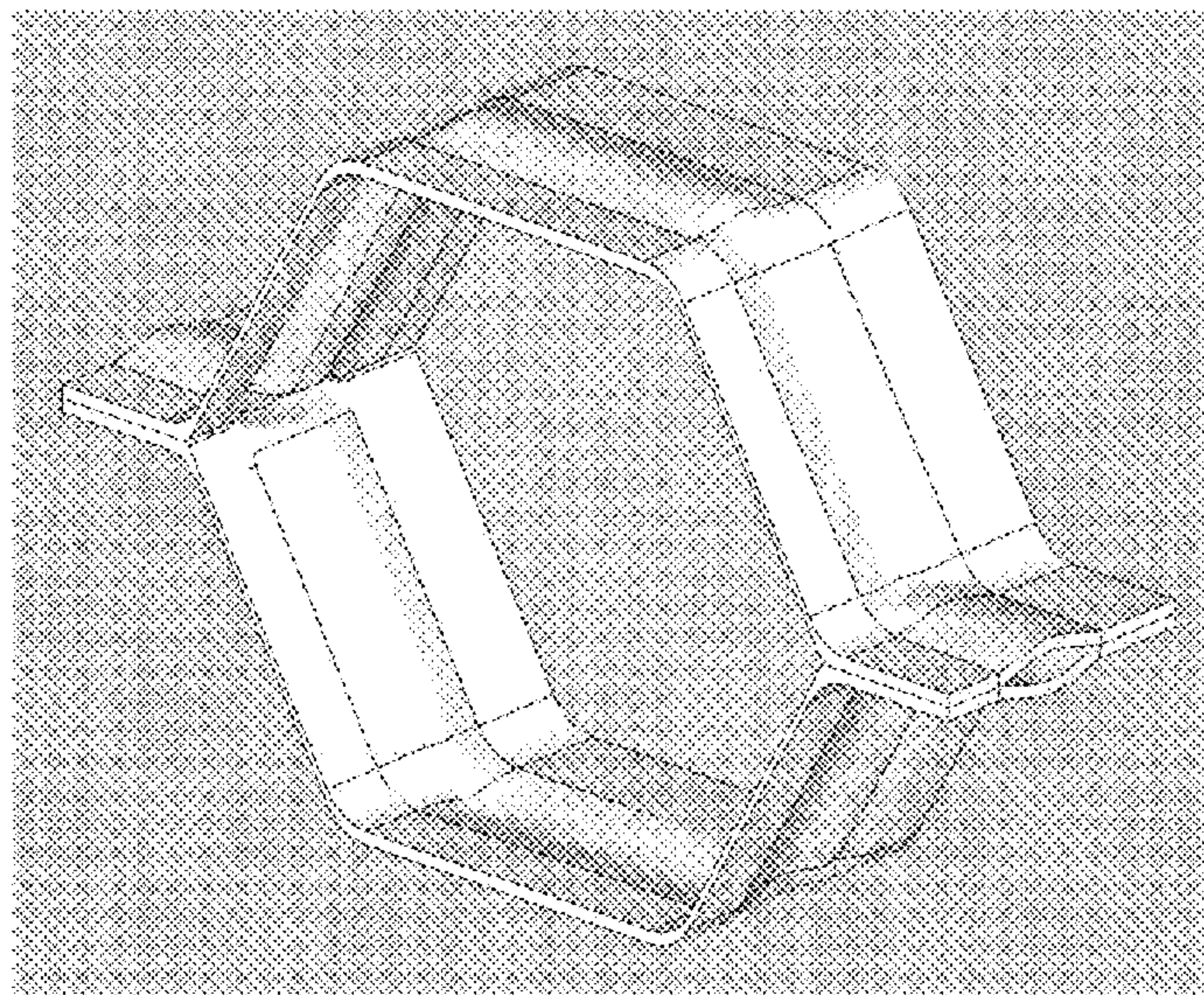

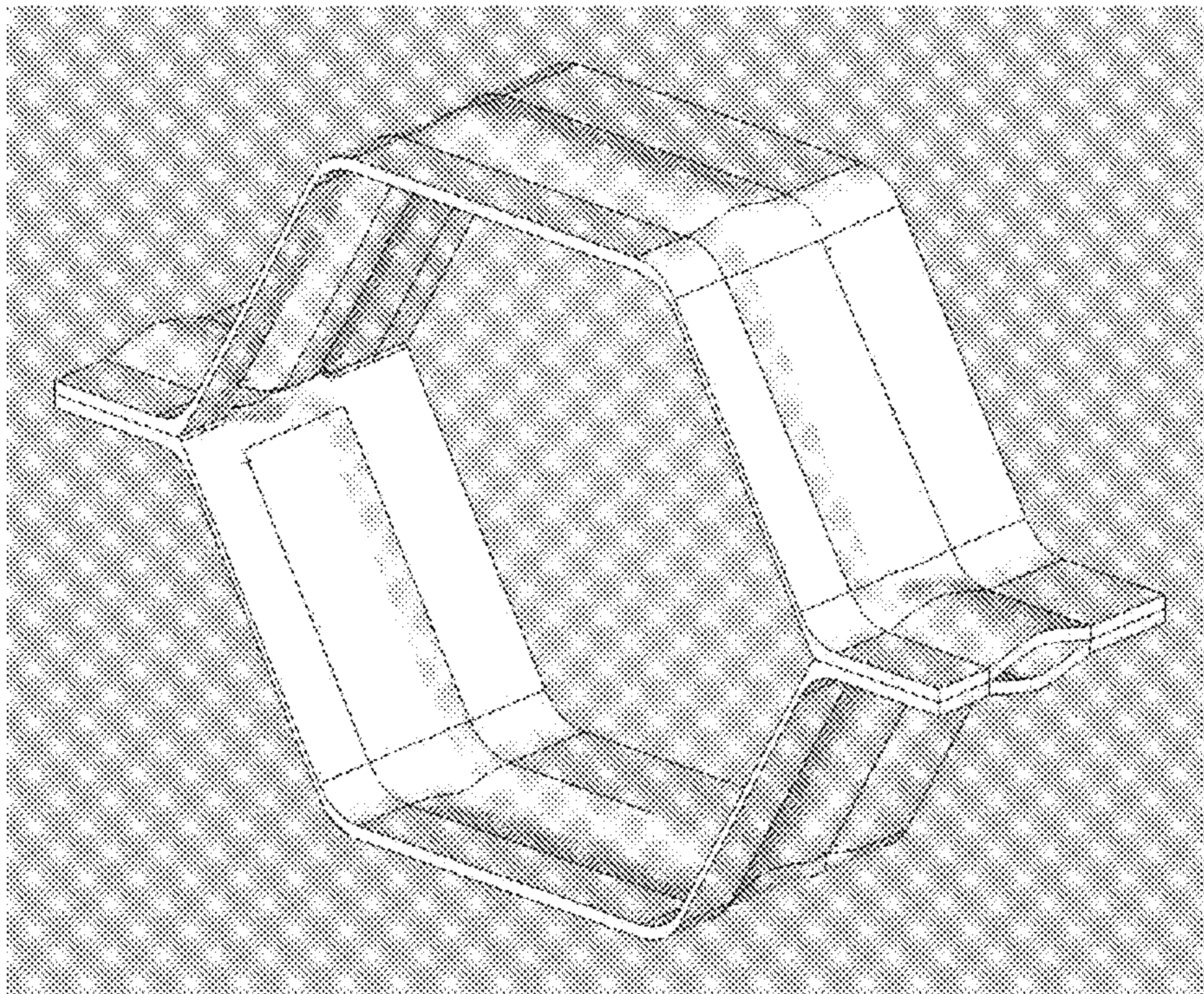

Fig. 1

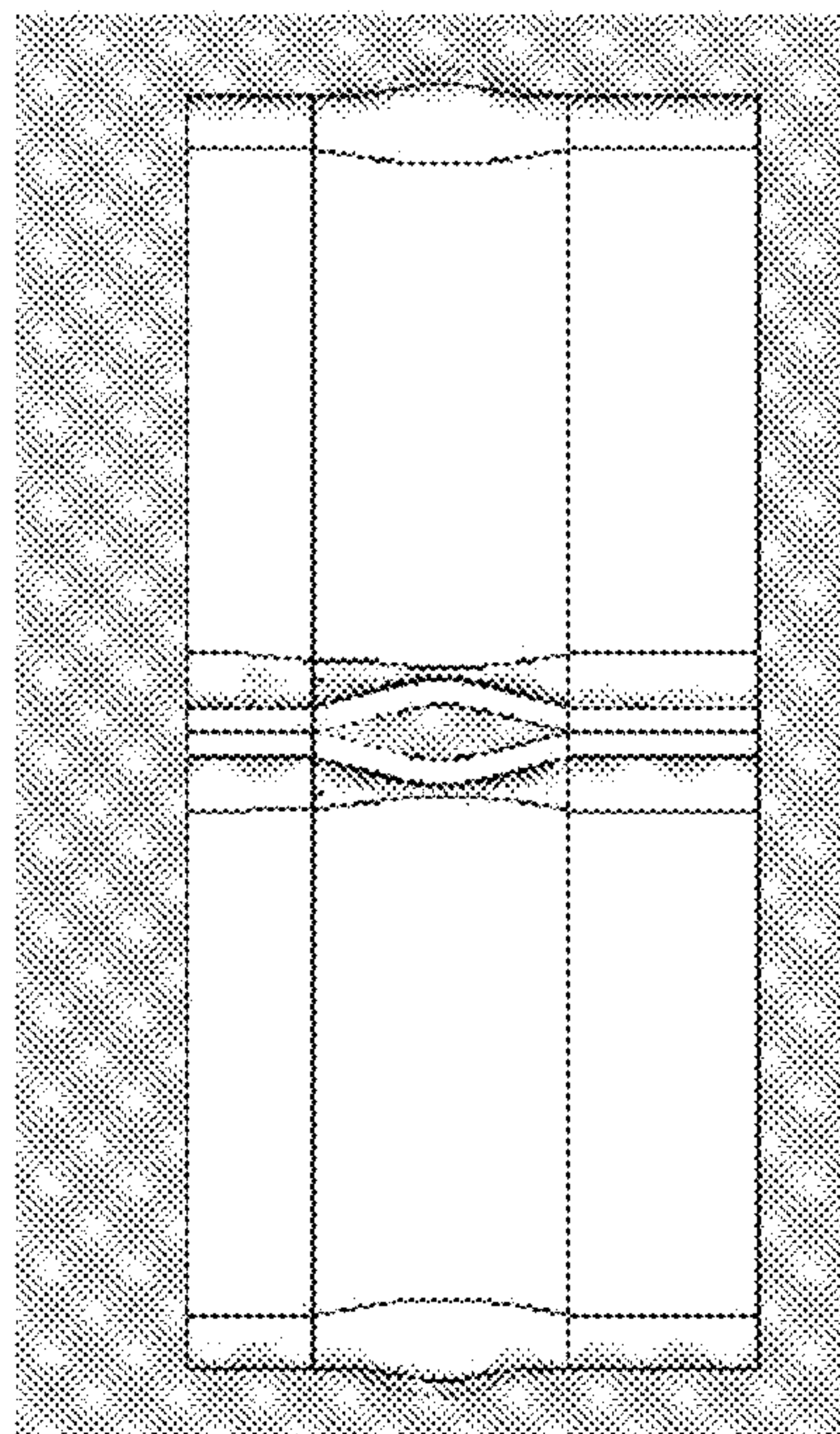

Fig. 2

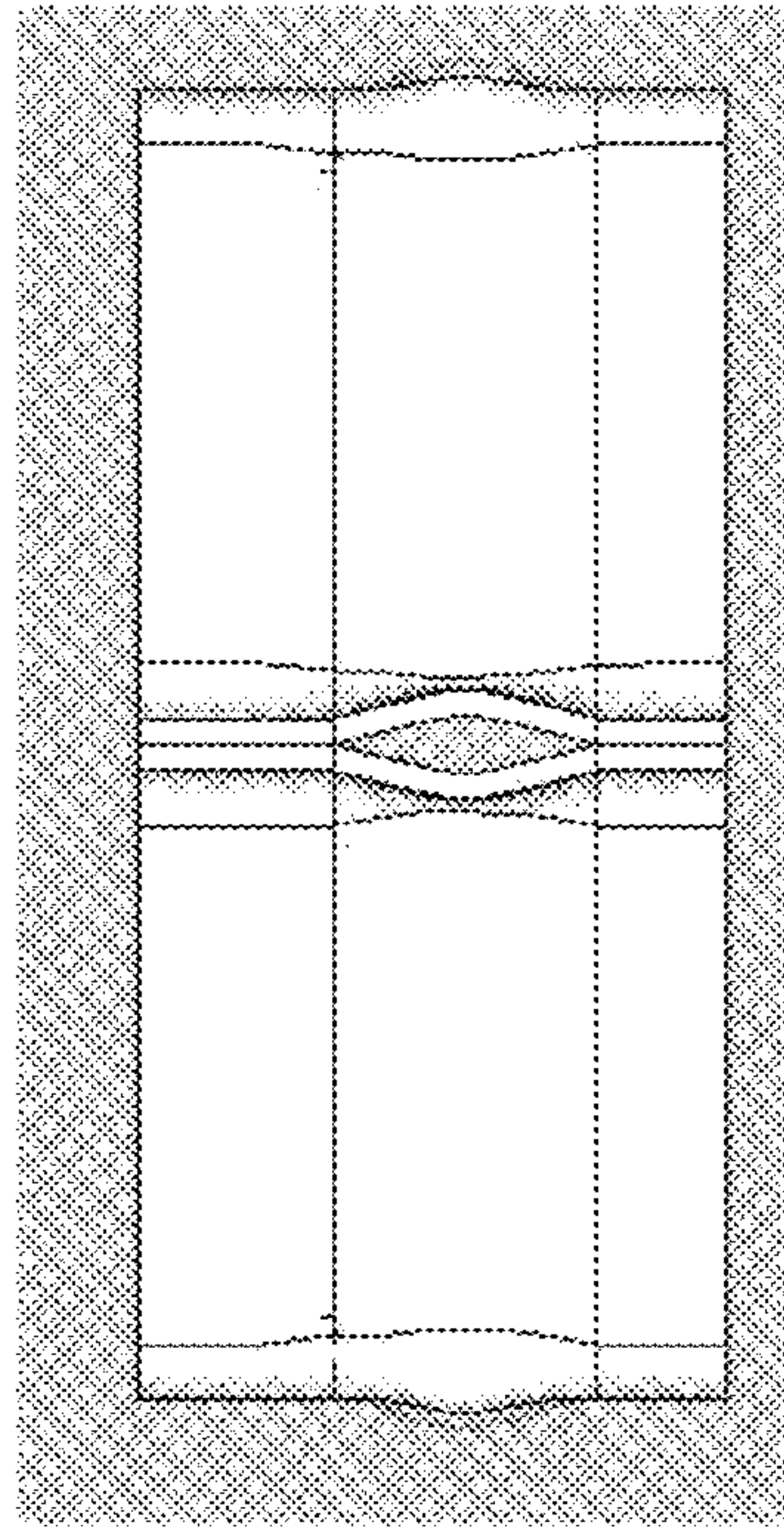

Fig. 3

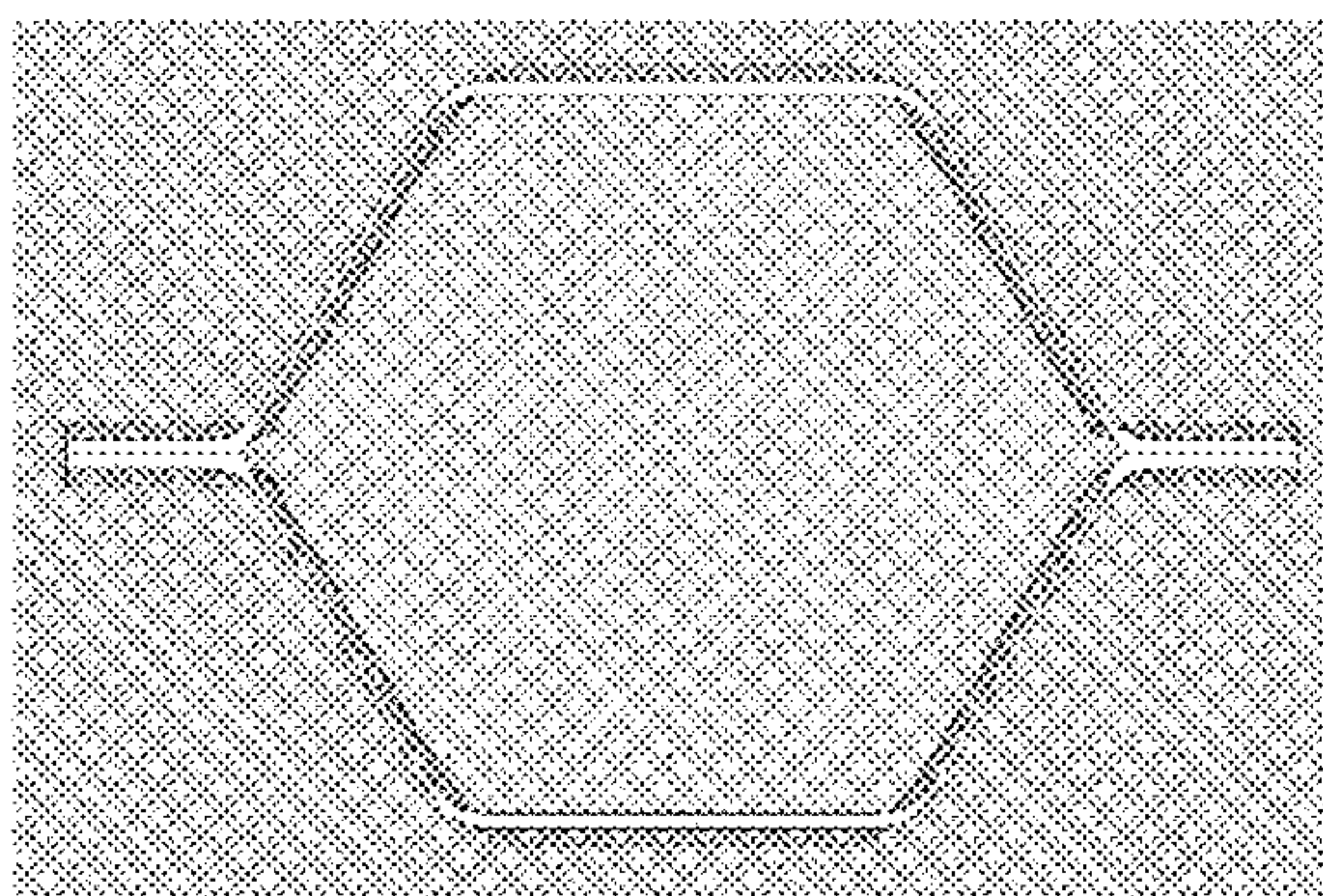

Fig. 4

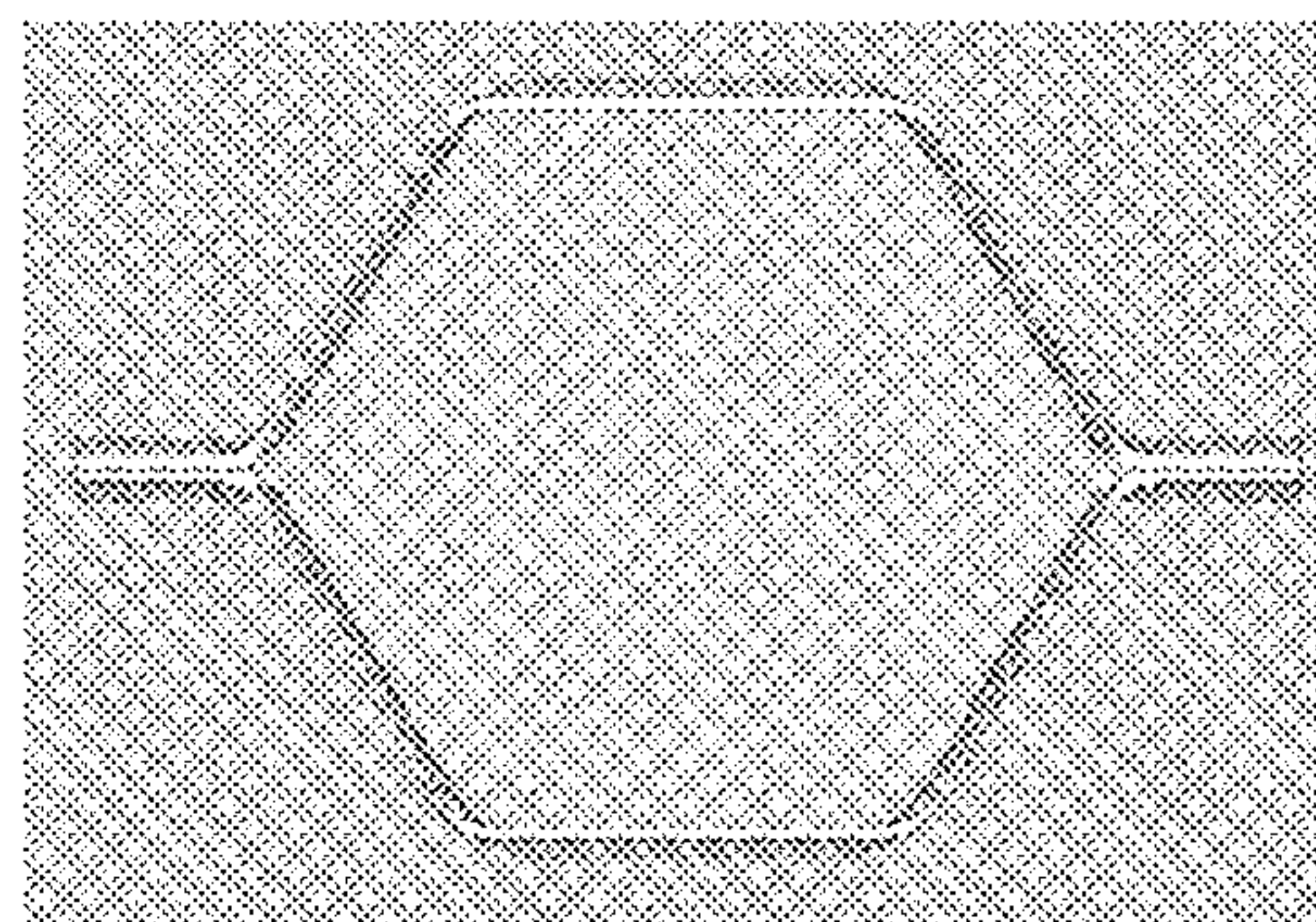

Fig. 5

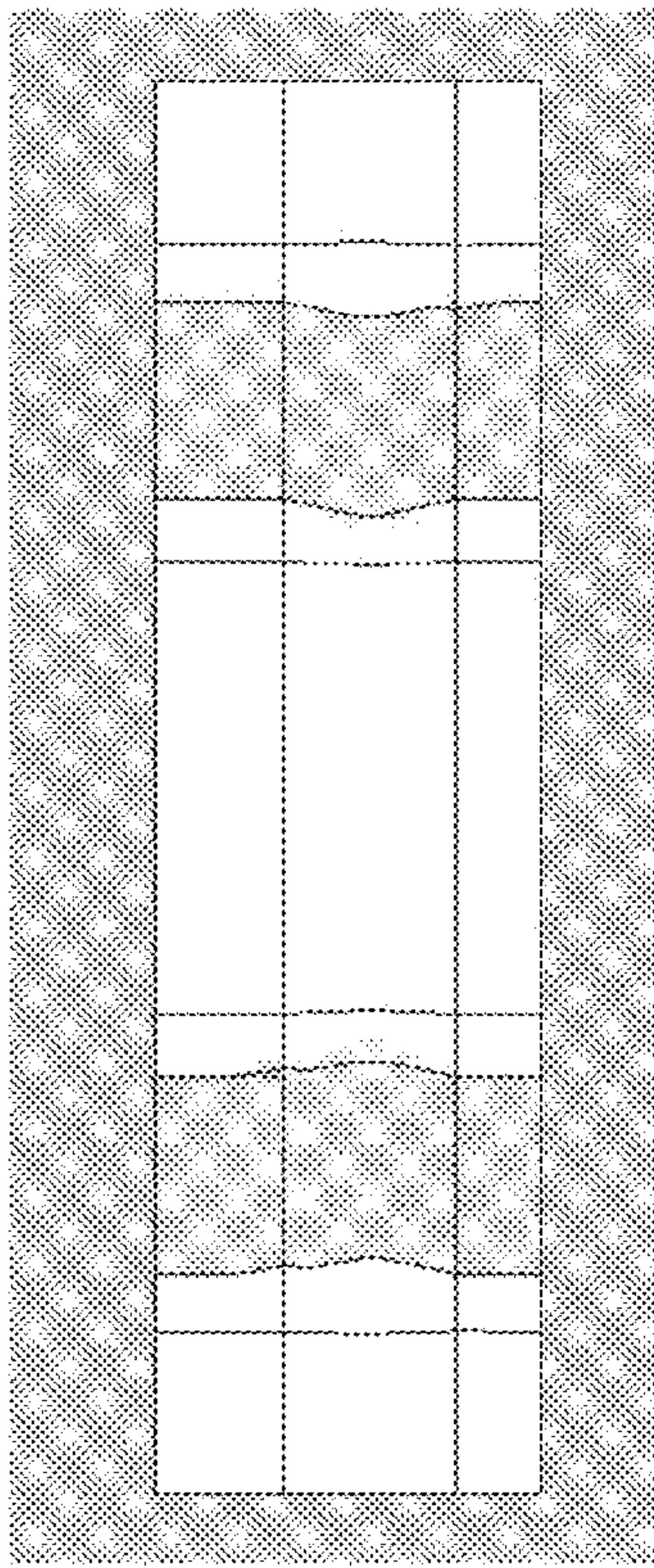

Fig. 6

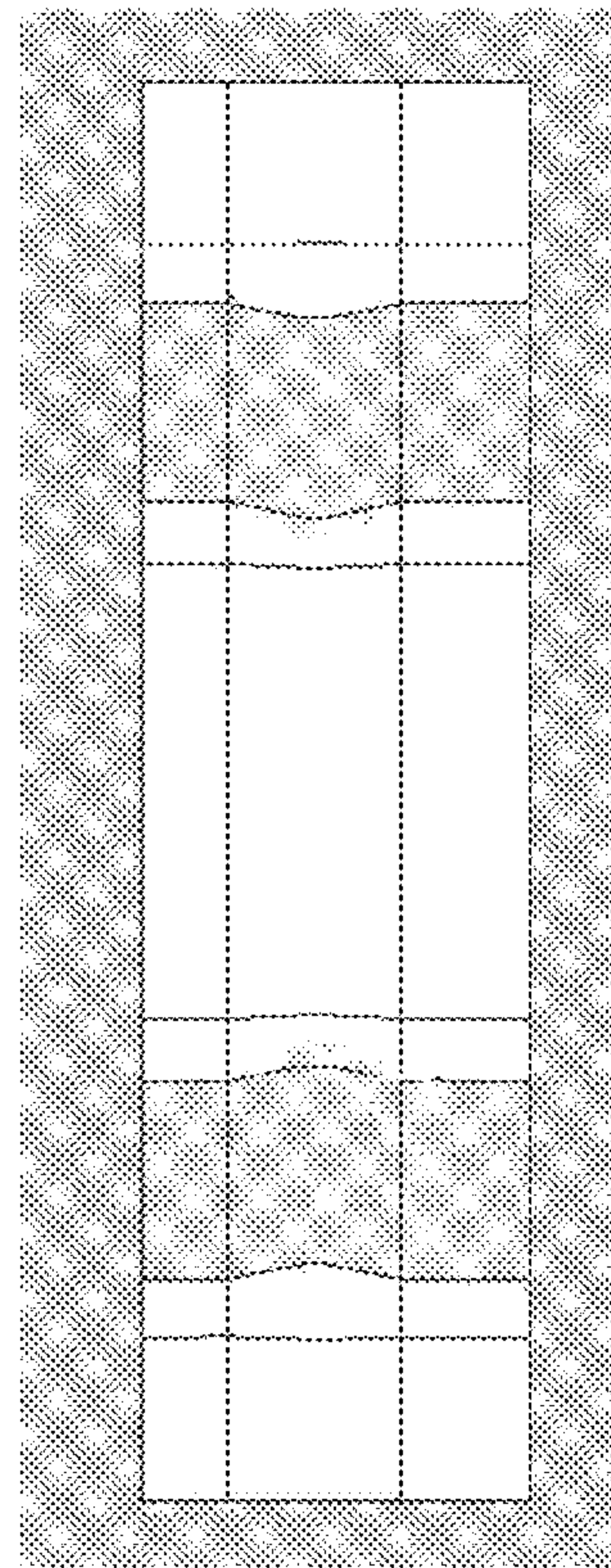

Fig. 7