



US00D816554S

(12) **United States Design Patent**
Wang et al.

(10) **Patent No.:** **US D816,554 S**
(45) **Date of Patent:** **** May 1, 2018**

(54) **BICYCLE**

(71) Applicant: **BEIJING MOBIKE TECHNOLOGY CO., LTD.**, Beijing (CN)

(72) Inventors: **Chao Wang**, Beijing (CN); **Weiwei Hu**, Beijing (CN); **Xiaofeng Wang**, Beijing (CN); **Yiping Xia**, Beijing (CN)

(73) Assignee: **BEIJING MOBIKE TECHNOLOGY CO., LTD.**, Beijing (CN)

(**) Term: **15 Years**

(21) Appl. No.: **29/574,731**

(22) Filed: **Aug. 18, 2016**

(30) **Foreign Application Priority Data**

Feb. 18, 2016 (CN) 2016 3 0046801

(51) **LOC (11) Cl.** **12-11**

(52) **U.S. Cl.**
USPC **D12/111**

(58) **Field of Classification Search**
USPC D12/111, 117; D21/412, 414, 419,
D21/423-428, 431-435
CPC B62K 3/00; B62K 3/02; B62K 3/06
See application file for complete search history.

(56) **References Cited**

U.S. PATENT DOCUMENTS

D414,721 S * 10/1999 Nakamura D12/110
D465,438 S * 11/2002 Masui D12/111

D574,756 S * 8/2008 Masui D12/111
D594,787 S * 6/2009 Dallaire D12/111
D621,302 S * 8/2010 Tanaka D12/111
D625,228 S * 10/2010 Lockart D12/111
D634,673 S * 3/2011 Lockart D12/111
D730,779 S * 6/2015 Arbour D12/111
D745,836 S * 12/2015 Poster D12/111
D789,836 S * 6/2017 Gouin D12/111
2011/0115193 A1 * 5/2011 Giroux B62H 5/006
280/281.1
2013/0255336 A1 * 10/2013 Desai E05B 71/00
70/431
2014/0209400 A1 * 7/2014 Yao B62M 6/45
180/167

* cited by examiner

Primary Examiner — Darlington Ly

(74) *Attorney, Agent, or Firm* — Alston & Bird LLP

(57) **CLAIM**

The ornamental design for a bicycle, as shown and described.

DESCRIPTION

FIG. 1 is a top, rear, and left side perspective view of a bicycle showing our new design;
FIG. 2 is a left side elevation view thereof;
FIG. 3 is a right side elevation view thereof;
FIG. 4 is a rear elevation view thereof;
FIG. 5 is a front elevation view thereof;
FIG. 6 is a top plan view thereof; and,
FIG. 7 is a bottom plan view thereof.

The broken lines in the drawings illustrate portions of the bicycle that do not form part of the claimed design.

1 Claim, 7 Drawing Sheets

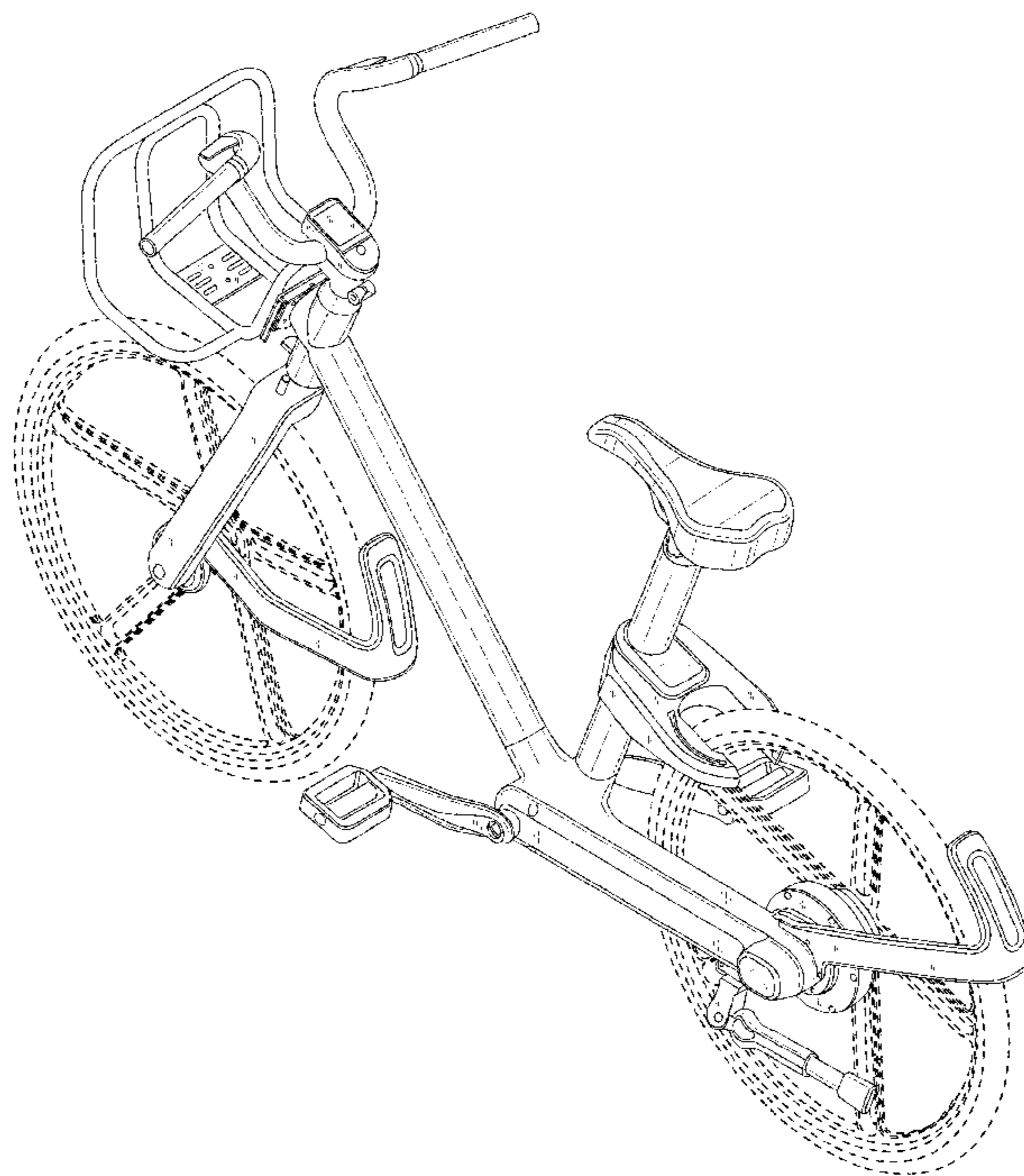

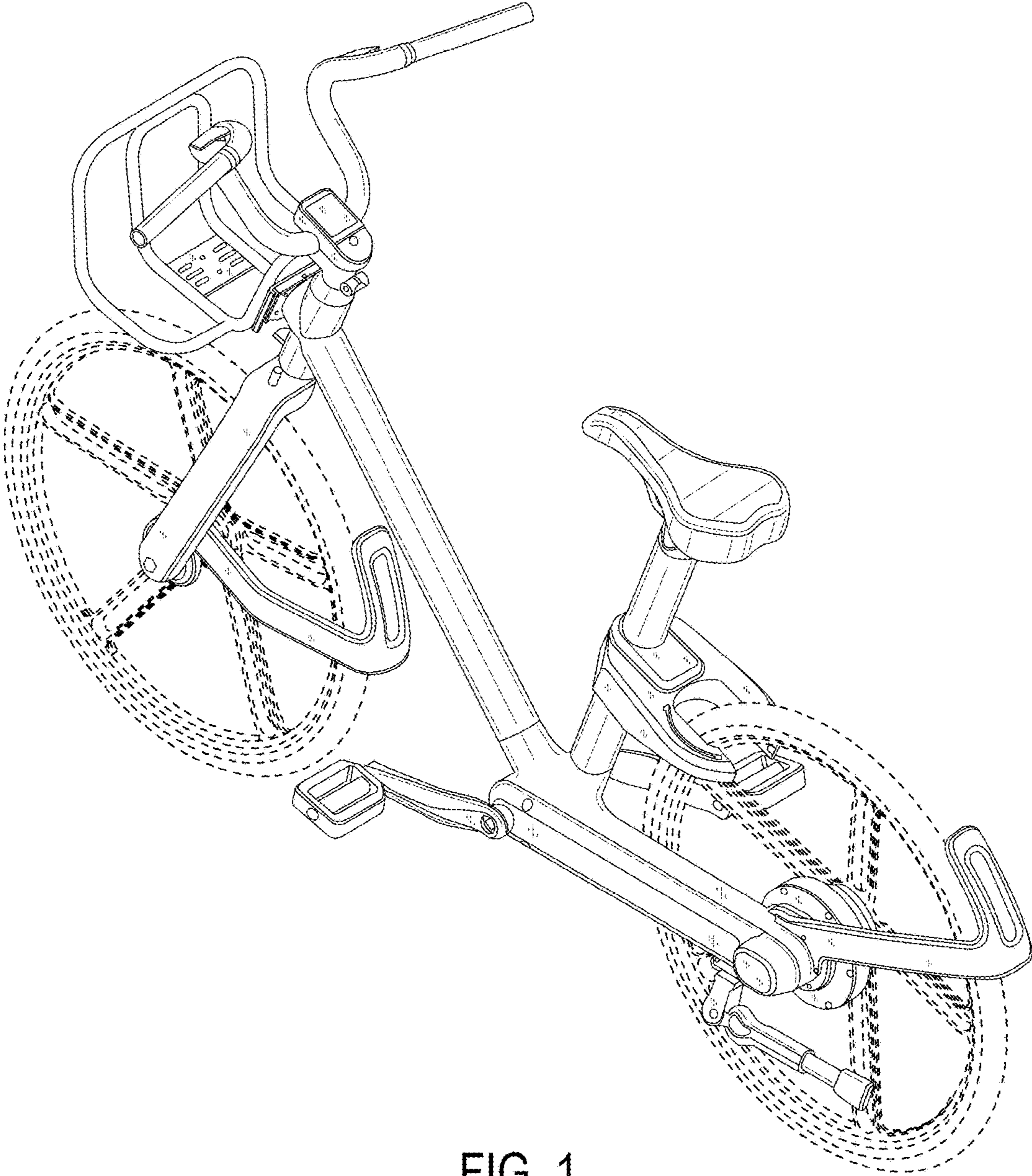

FIG. 1

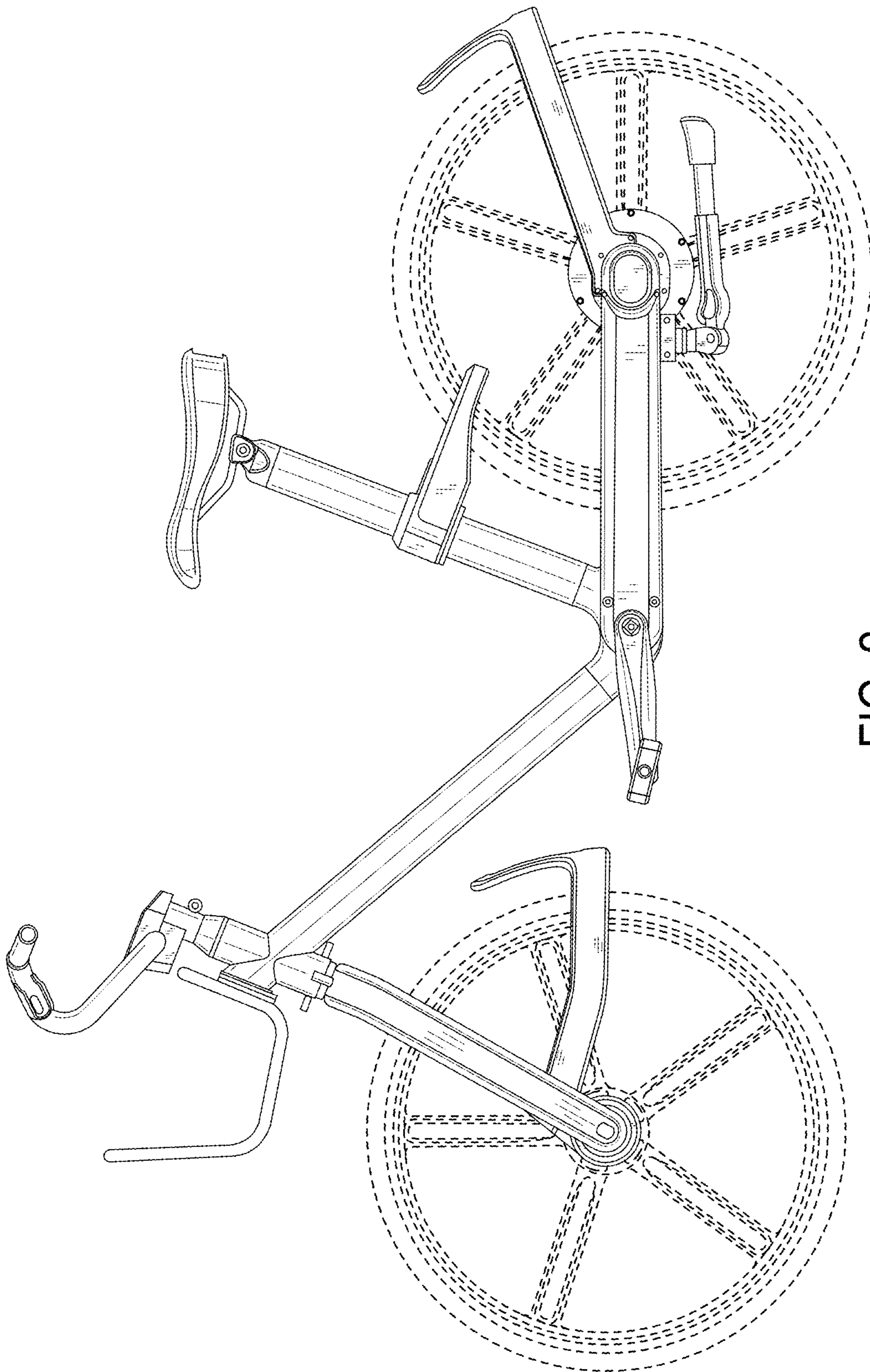

FIG. 2

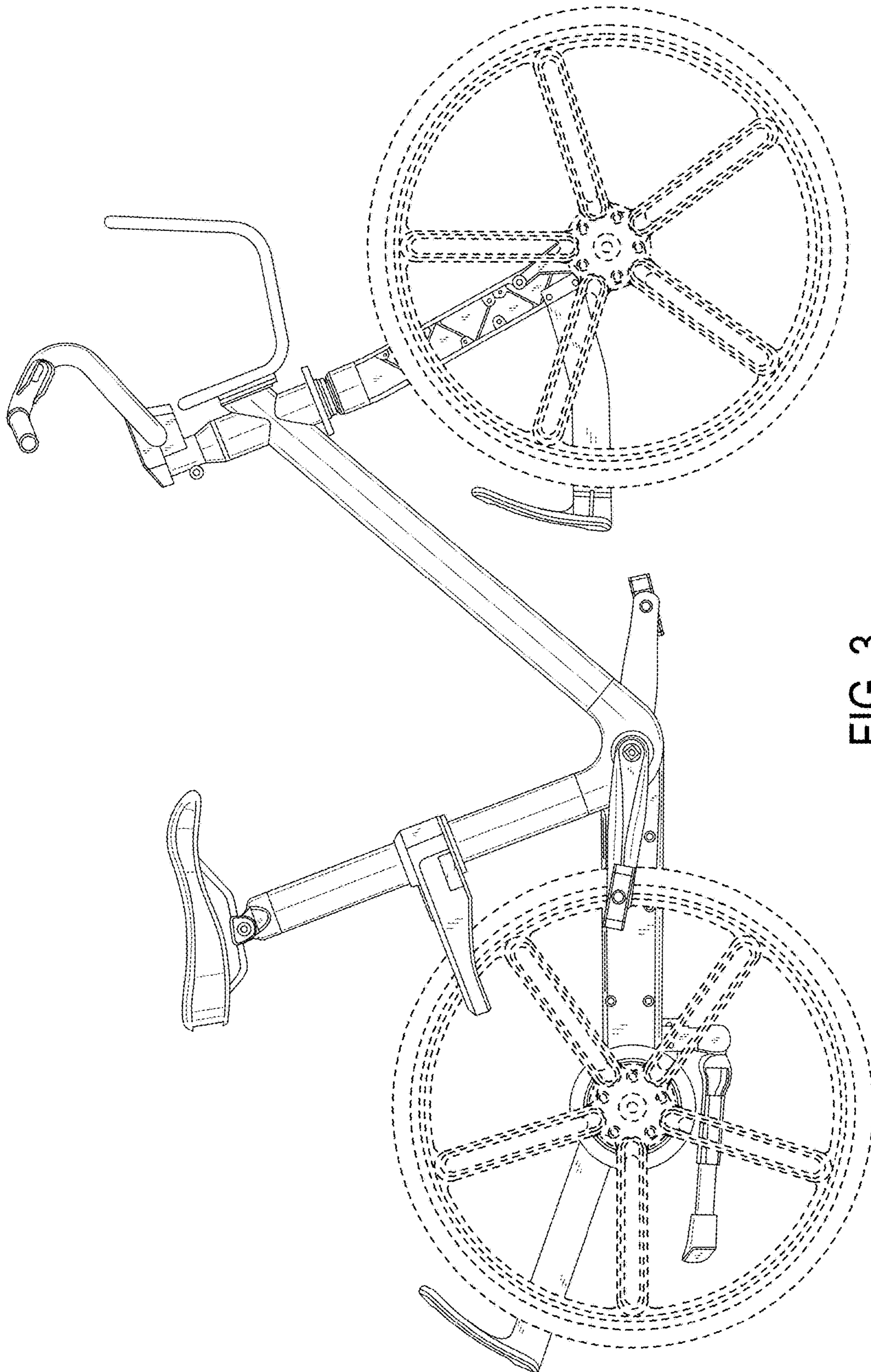

FIG. 3

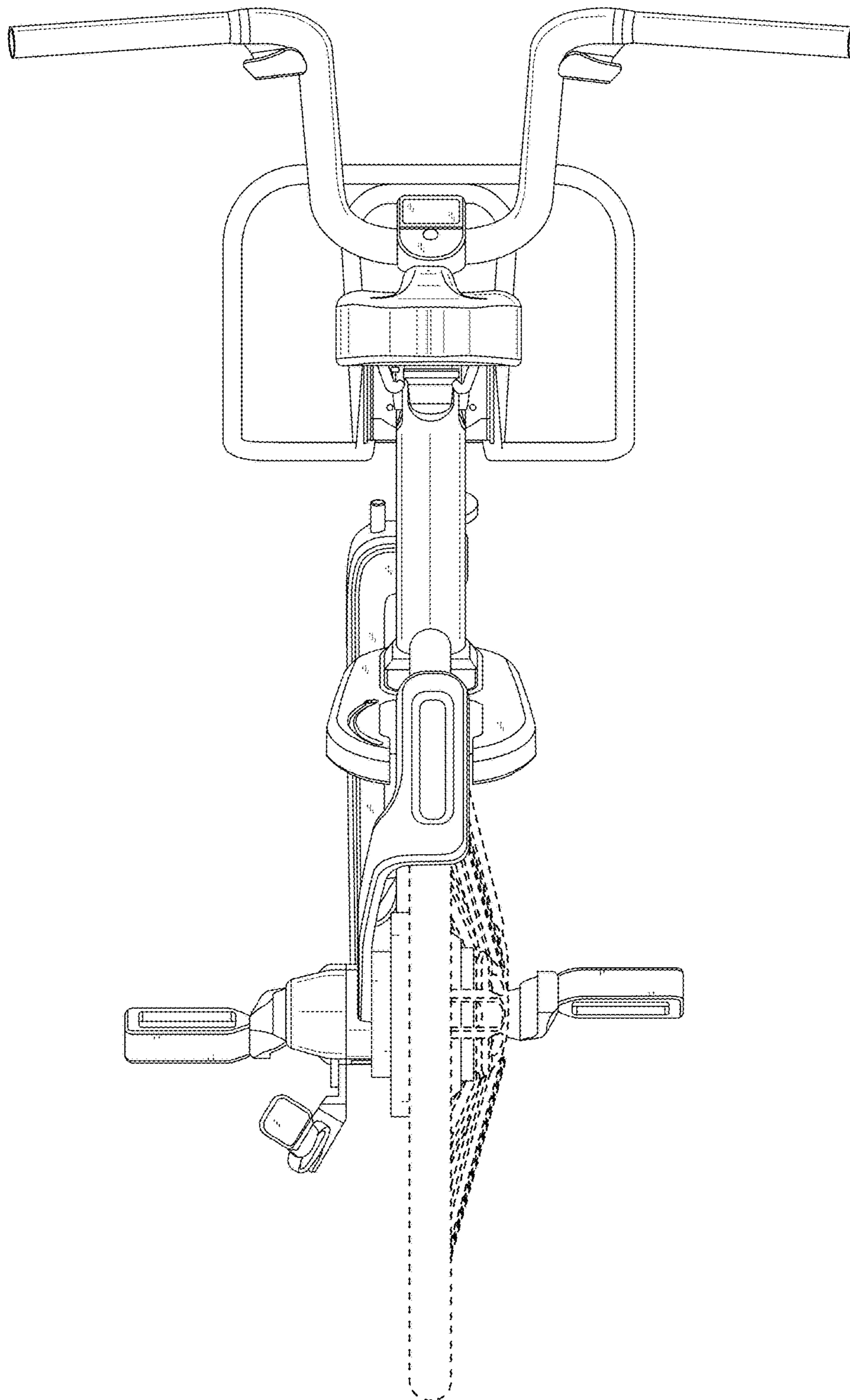

FIG. 4

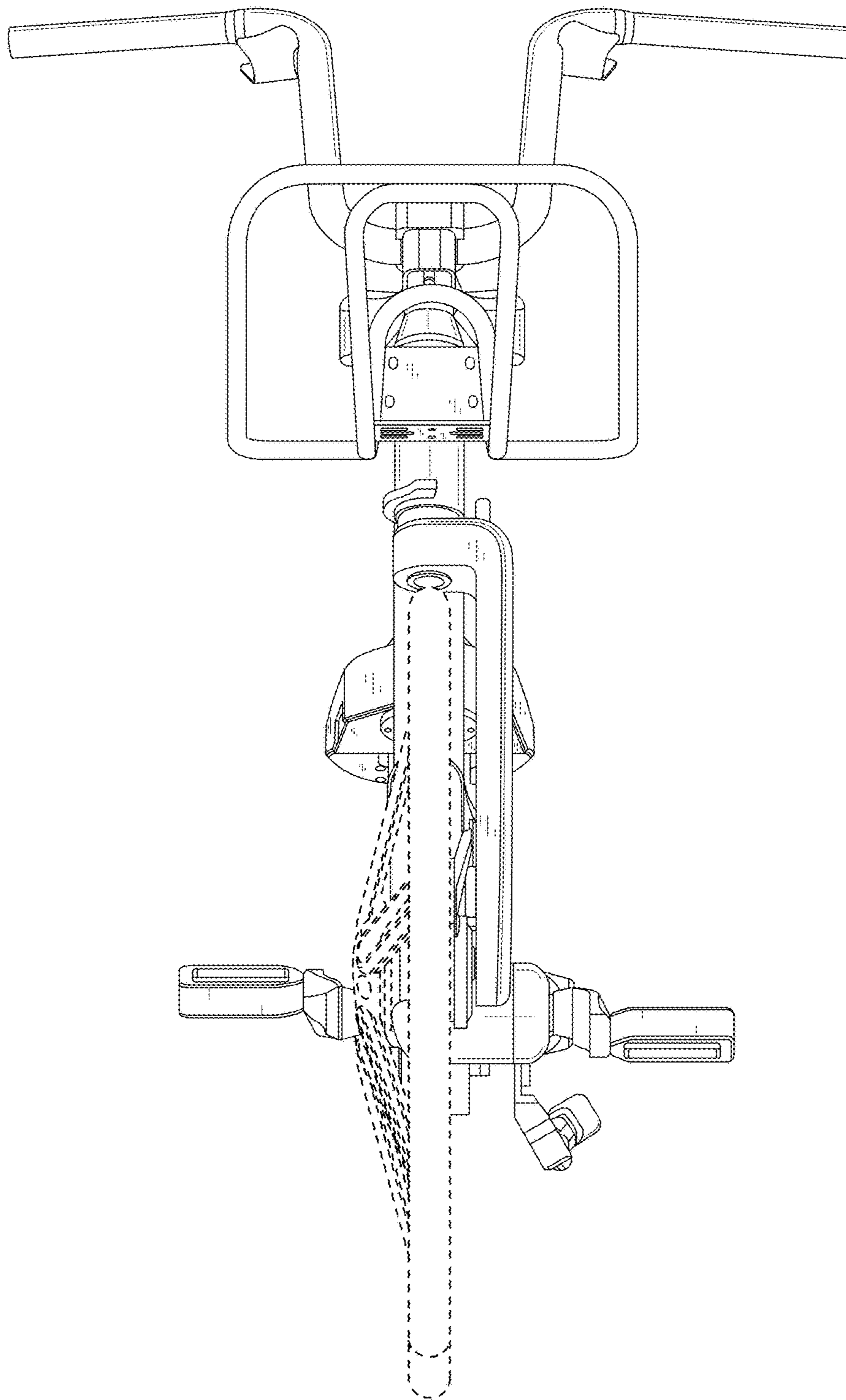

FIG. 5

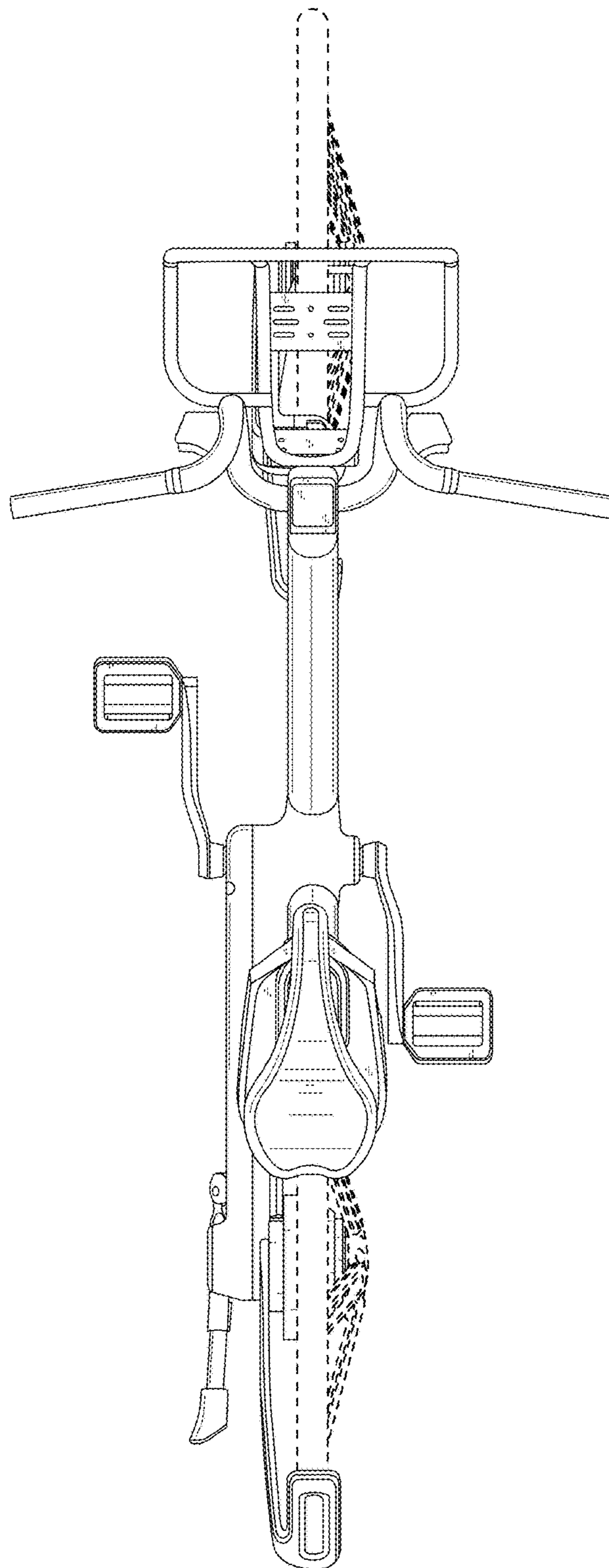

FIG. 6

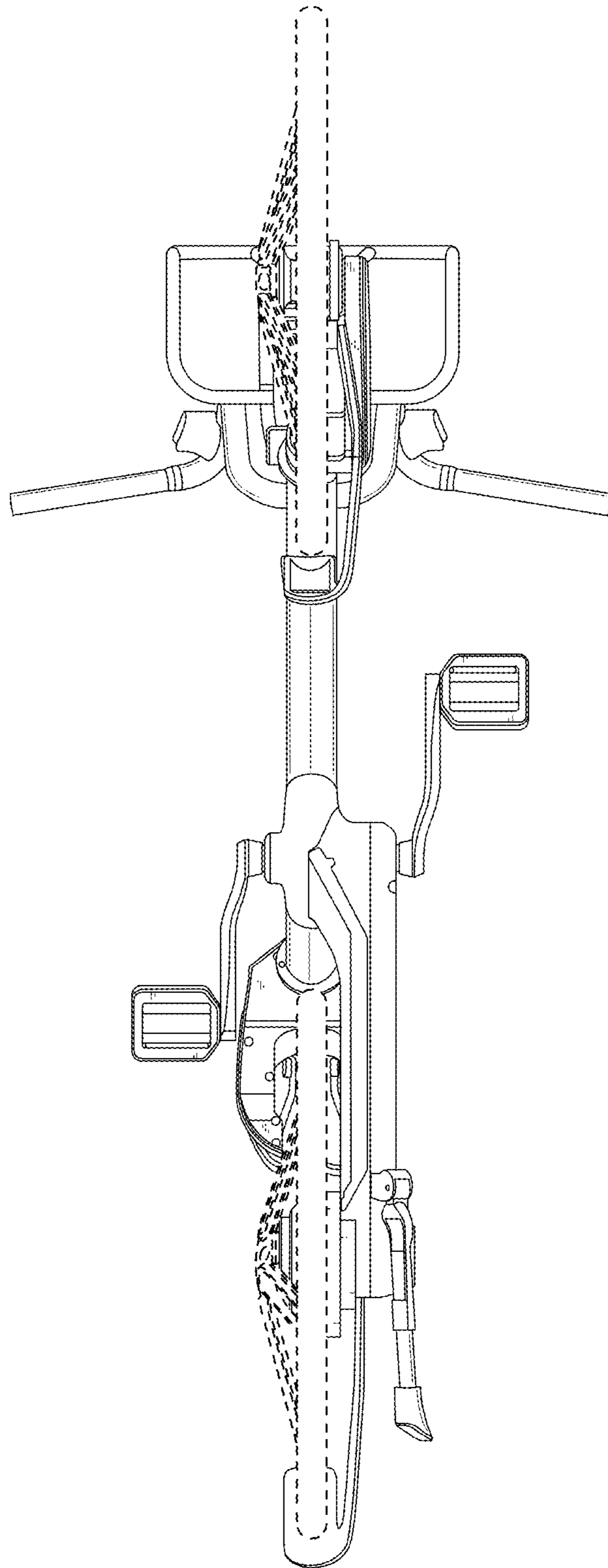

FIG. 7