



US00D816044S

(12) **United States Design Patent**
Zerebilov et al.

(10) **Patent No.:** **US D816,044 S**
(45) **Date of Patent:** **** Apr. 24, 2018**

(54) **ELECTRICAL CABLE CONNECTOR**

FOREIGN PATENT DOCUMENTS

(71) Applicant: **FCI Americas Technology LLC**,
Carson City, NV (US)

DE 1665181 4/1974
DE 3529218 2/1986

(Continued)

(72) Inventors: **Arkady Y. Zerebilov**, Lancaster, PA
(US); **Deborah A. Ingram**, Eppers, PA
(US); **Hung-Wei Lord**, Harrisburg, PA
(US); **Jonathan E. Buck**, Milpitas, CA
(US); **Stuart C. Stoner**, Lewisberry, PA
(US); **Jason J. Ellison**, New
Cumberland, PA (US)

OTHER PUBLICATIONS

U.S. Appl. No. 29/418,299, filed Apr. 13, 2012, Buck et al.
(Continued)

Primary Examiner — Daniel Bui

(73) Assignee: **FCI Americas Technology LLC**,
Carson City, NV (US)

(74) *Attorney, Agent, or Firm* — Wolf, Greenfield &
Sacks, P.C.

(**) Term: **15 Years**

(21) Appl. No.: **29/549,285**

(57) **CLAIM**

(22) Filed: **Dec. 21, 2015**

The ornamental design for an electrical cable connector, as
shown and described.

Related U.S. Application Data

(63) Continuation of application No. 29/508,070, filed on
Nov. 3, 2014, now Pat. No. Des. 750,030, which is a
(Continued)

DESCRIPTION

(51) **LOC (11) Cl.** **13-03**

(52) **U.S. Cl.**
USPC **D13/154**

(58) **Field of Classification Search**
USPC D13/133, 146, 147, 154, 184, 199
CPC H01R 12/00; H01R 12/724; H01R 13/00;
H01R 13/28; H01R 12/7005; H01R
12/737; H01R 13/516; H01R 13/6463;
H01R 13/6471; H01R 13/6585; H01R
13/6587

FIG. 1 is a top, right, front perspective view for an electrical
cable connector in accordance with our design;
FIG. 2 is a bottom, left, front perspective view thereof;
FIG. 3 is a top, left, rear perspective view thereof;
FIG. 4 is a bottom, left, rear perspective view thereof;
FIG. 5 is a front elevation view thereof;
FIG. 6 is a rear elevation view thereof;
FIG. 7 is a top plan view thereof;
FIG. 8 is a bottom plan view thereof;
FIG. 9 is a left side elevation view thereof; and,
FIG. 10 is a right side elevation view thereof.

See application file for complete search history.

The dashed broken line portions of the figures are included
to show unclaimed subject matter only for the purpose of
illustrating environment and form no part of the claimed
design. The dash-dot broken lines define boundaries of the
claimed design, and form no part of the claimed design.

(56) **References Cited**

U.S. PATENT DOCUMENTS

318,186 A 5/1885 Hertzog
741,052 A 10/1903 Mahon

(Continued)

1 Claim, 4 Drawing Sheets

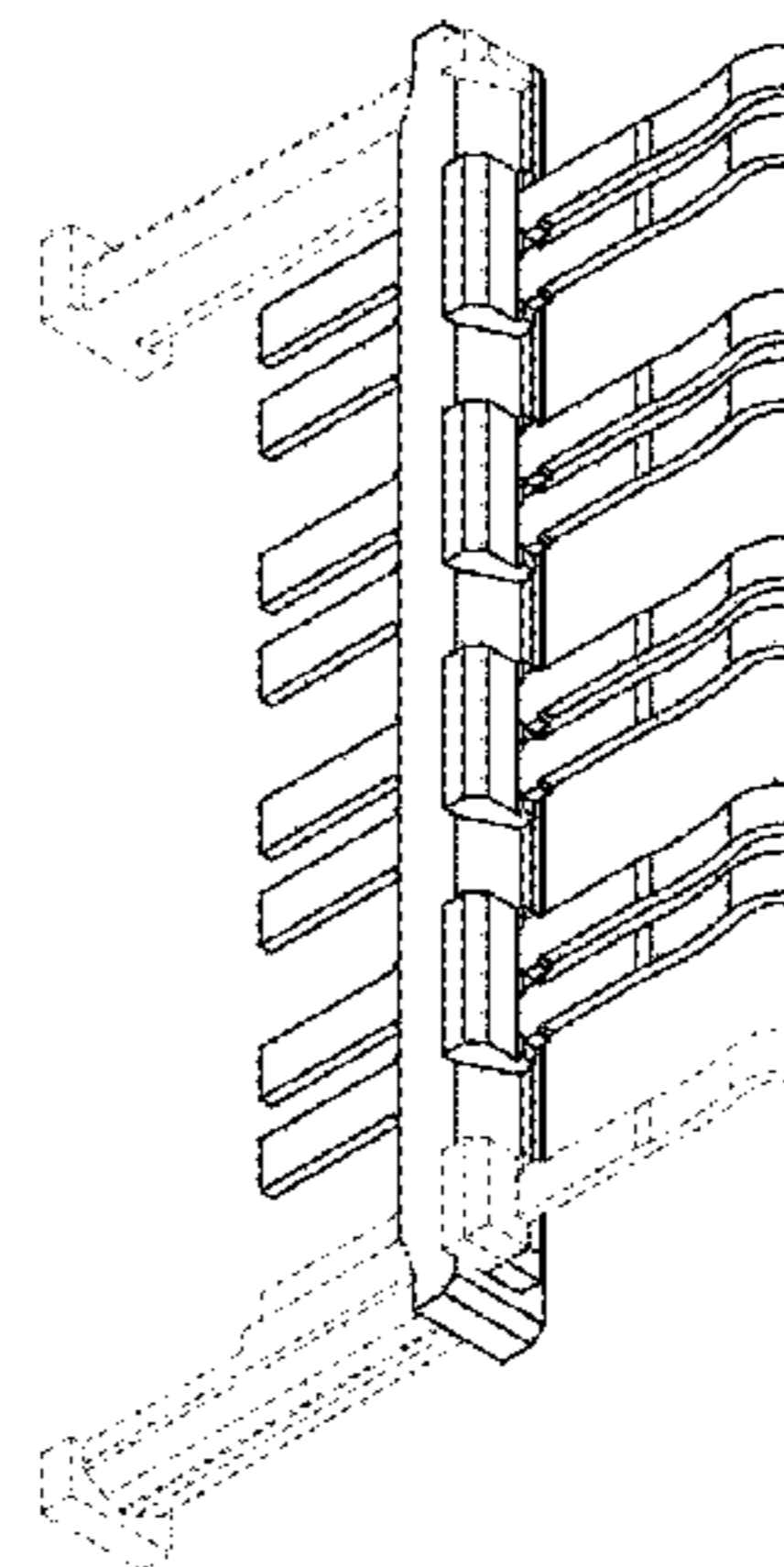
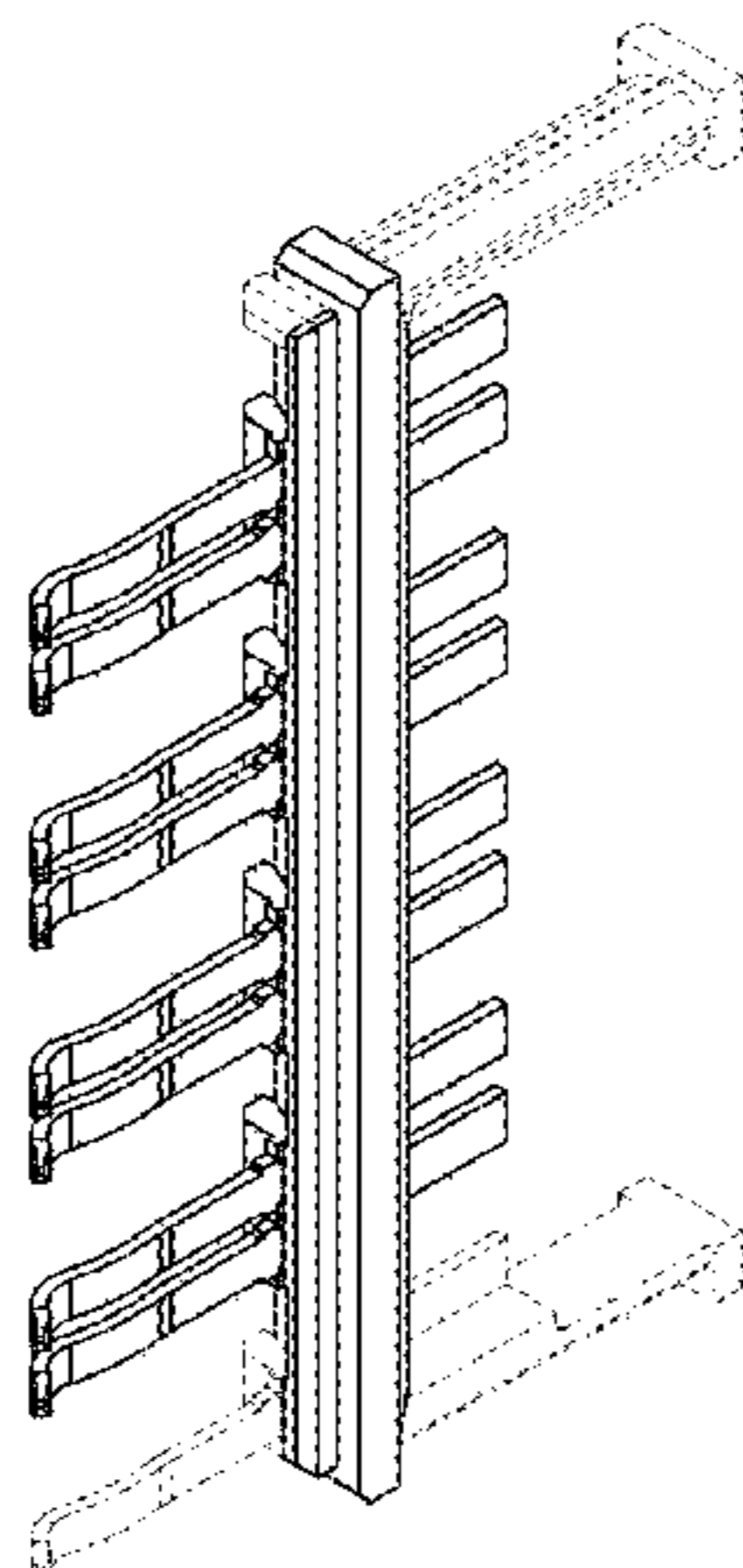

Related U.S. Application Data

continuation of application No. 29/418,313, filed on
Apr. 13, 2012, now Pat. No. Des. 718,253.

(56)

References Cited

U.S. PATENT DOCUMENTS

1,477,527 A	12/1923	Raettig	4,464,003 A	8/1984	Goodman et al.
D86,515 S	3/1932	Cox	4,473,113 A	9/1984	Whitfield et al.
2,231,347 A	2/1941	Reutter	4,473,477 A	9/1984	Beall
2,248,675 A	7/1941	Huppert	D275,849 S	10/1984	Sakurai
2,430,011 A	11/1947	Gillentine	4,482,937 A	11/1984	Berg
2,664,552 A	12/1953	Ericsson et al.	4,505,529 A	3/1985	Barkus
2,759,163 A	8/1956	Ustin et al.	4,523,296 A	6/1985	Healy, Jr.
2,762,022 A	9/1956	Benander et al.	4,533,187 A	8/1985	Kirkman
2,849,700 A	4/1958	Perkin	4,536,955 A	8/1985	Gudgeon
2,844,644 A	7/1958	Soule, Jr.	4,545,610 A	10/1985	Lakritz et al.
2,858,372 A	10/1958	Kaufman	4,552,425 A	11/1985	Billman
3,011,143 A	11/1961	Dean	4,560,222 A	12/1985	Dambach
3,115,379 A	12/1963	McKee	4,564,259 A	1/1986	Vandame
3,178,669 A	4/1965	Roberts	4,592,846 A	6/1986	Metzger et al.
3,179,738 A	4/1965	De Lyon	4,596,428 A	6/1986	Tengler
3,208,030 A	9/1965	Evans et al.	4,596,433 A	6/1986	Oesterheld et al.
3,286,220 A	11/1966	Marley et al.	4,624,604 A	11/1986	Wagner et al.
3,320,658 A	5/1967	Bolda et al.	4,632,476 A	12/1986	Schell
3,337,838 A	8/1967	Damiano et al.	4,641,426 A	2/1987	Hartman et al.
3,343,120 A	9/1967	Whiting	4,655,515 A	4/1987	Hamsher, Jr. et al.
3,366,729 A	1/1968	Pauza	4,664,309 A	5/1987	Allen et al.
3,411,127 A	11/1968	Adams	4,664,456 A	5/1987	Blair et al.
3,420,087 A	1/1969	Hatfield et al.	4,664,458 A	5/1987	Worth
D213,697 S	4/1969	Oxley	4,678,250 A	7/1987	Romine et al.
3,482,201 A	12/1969	Schneck	4,685,886 A	8/1987	Denlinger et al.
3,514,740 A	5/1970	Filson et al.	4,705,205 A	11/1987	Allen et al.
3,538,486 A	11/1970	Shlesinger, Jr.	4,705,332 A	11/1987	Sadigh-Behzadi
3,560,908 A	2/1971	Dell et al.	4,717,360 A	1/1988	Czaja
3,591,834 A	7/1971	Kolias	4,722,470 A	2/1988	Johary
3,634,811 A	1/1972	Teagno	4,734,060 A	3/1988	Kawawada et al.
3,641,475 A	2/1972	Irish et al.	4,762,500 A	8/1988	Dola et al.
3,663,925 A	5/1972	Proctor	4,767,344 A	8/1988	Noschese
3,669,054 A	6/1972	Desso et al.	4,776,803 A	10/1988	Pretchel et al.
3,692,994 A	9/1972	Hirschman et al.	4,782,893 A	11/1988	Thomas
3,701,076 A	10/1972	Irish	4,790,763 A	12/1988	Weber et al.
3,719,981 A	3/1973	Steitz	4,806,107 A	2/1989	Arnold et al.
3,732,697 A	5/1973	Dickson	4,815,987 A	3/1989	Kawano et al.
3,748,633 A	7/1973	Lundergan	4,818,237 A	4/1989	Weber
3,827,005 A	7/1974	Friend	4,820,169 A	4/1989	Weber et al.
3,845,451 A	10/1974	Neidecker	4,820,182 A	4/1989	Harwath et al.
3,864,004 A	2/1975	Friend	4,824,383 A	4/1989	Lemke
3,865,462 A	2/1975	Cobaugh et al.	4,830,264 A	5/1989	Bitailou et al.
3,867,008 A	2/1975	Gartland, Jr.	4,836,791 A	6/1989	Grabbe et al.
3,871,015 A	3/1975	Lin et al.	4,844,813 A	7/1989	Helfgott et al.
3,889,364 A	6/1975	Krueger	4,846,727 A	7/1989	Glover et al.
3,942,856 A	3/1976	Mindheim et al.	4,850,887 A	7/1989	Sugawara
3,972,580 A	8/1976	Pemberton et al.	4,854,899 A	8/1989	Matthews
4,030,792 A	6/1977	Fuerst	4,867,713 A	9/1989	Ozu et al.
4,056,302 A	11/1977	Braun et al.	4,871,110 A	10/1989	Fukasawa et al.
4,070,088 A	1/1978	Vaden	4,878,611 A	11/1989	LoVasco et al.
4,076,362 A	2/1978	Ichimura	4,881,905 A	11/1989	Demler et al.
4,082,407 A	4/1978	Smorzaniuk et al.	4,882,554 A	11/1989	Akaba et al.
4,097,266 A	6/1978	Takahashi et al.	4,884,335 A	12/1989	McCoy et al.
4,136,919 A	1/1979	Howard et al.	4,898,539 A	2/1990	Glover et al.
4,140,361 A	2/1979	Sochor	4,900,271 A	2/1990	Colleran et al.
4,159,861 A	7/1979	Anhalt	4,904,212 A	2/1990	Durbin et al.
4,217,024 A	8/1980	Aldridge et al.	4,907,990 A	3/1990	Bertho et al.
4,232,924 A	11/1980	Kline et al.	4,908,129 A	3/1990	Finsterwalder et al.
4,260,212 A	4/1981	Ritchie et al.	4,913,664 A	4/1990	Dixon et al.
4,274,700 A	6/1981	Keglewitsch et al.	4,915,641 A	4/1990	Miskin et al.
4,288,139 A	9/1981	Cobaugh et al.	4,917,616 A	4/1990	Demler, Jr. et al.
4,371,912 A	2/1983	Guzik	4,952,172 A	8/1990	Barkus et al.
4,380,518 A	4/1983	Wydro, Sr.	4,963,102 A	10/1990	Gettig et al.
4,383,724 A	5/1983	Verhoevan	4,965,699 A	10/1990	Jordan et al.
4,395,086 A	7/1983	Marsh	4,973,257 A	11/1990	Lhotak
4,396,140 A	8/1983	Jaffe et al.	4,973,271 A	11/1990	Ishizuka et al.
4,402,563 A	9/1983	Sinclair	4,974,119 A	11/1990	Martin
4,403,821 A	9/1983	Zimmerman et al.	4,975,069 A	12/1990	Fedder et al.
4,448,467 A	5/1984	Weidler	4,975,084 A	12/1990	Fedder et al.
4,462,534 A	7/1984	Bitailou et al.	4,979,074 A	12/1990	Morley et al.
			4,997,390 A	3/1991	Scholz et al.
			5,004,426 A	4/1991	Barnett
			5,016,968 A	5/1991	Hammond et al.
			5,024,372 A	6/1991	Altman et al.
			5,024,610 A	6/1991	French et al.
			5,035,631 A	7/1991	Piorunneck et al.
			5,035,639 A	7/1991	Kilpatrick et al.
			5,046,960 A	9/1991	Fedder et al.
			5,052,953 A	10/1991	Weber

(56)

References Cited

U.S. PATENT DOCUMENTS

5,055,054 A	10/1991	Doutrich	5,387,111 A	2/1995	DeSantis et al.
5,060,844 A	10/1991	Behun et al.	5,387,139 A	2/1995	McKee et al.
5,065,282 A	11/1991	Polonio	5,395,250 A	3/1995	Englert, Jr. et al.
5,066,236 A	11/1991	Broeksteeg	5,400,949 A	3/1995	Hirvonen et al.
5,077,893 A	1/1992	Mosquera et al.	5,403,206 A	4/1995	McNamara et al.
5,082,459 A	1/1992	Billman et al.	5,409,157 A	4/1995	Nagesh et al.
5,083,238 A	1/1992	Bousman	5,410,807 A	5/1995	Bross et al.
5,093,986 A	3/1992	Mandai et al.	5,427,543 A	6/1995	Dynia
5,094,623 A	3/1992	Scharf et al.	5,429,520 A	7/1995	Morlion et al.
5,094,634 A	3/1992	Dixon et al.	5,429,521 A	7/1995	Morlion et al.
5,098,311 A	3/1992	Roath et al.	5,431,332 A	7/1995	Kirby et al.
5,104,332 A	4/1992	McCoy	5,431,578 A	7/1995	Wayne
5,104,341 A	4/1992	Gilissen et al.	5,433,617 A	7/1995	Morlion et al.
5,111,991 A	5/1992	Clawson et al.	5,433,618 A	7/1995	Morlion et al.
5,117,331 A	5/1992	Gebara	5,435,482 A	7/1995	Variot et al.
5,118,027 A	6/1992	Braun et al.	5,442,852 A	8/1995	Danner
5,120,237 A	6/1992	Fussell	5,445,313 A	8/1995	Boyd et al.
5,127,839 A	7/1992	Korsunsky et al.	5,457,342 A	10/1995	Herbst, II
5,131,871 A	7/1992	Banakis et al.	5,458,426 A	10/1995	Ito
5,137,959 A	8/1992	Block et al.	5,462,456 A	10/1995	Howell
5,139,426 A	8/1992	Barkus et al.	5,467,913 A	11/1995	Namekawa et al.
5,145,104 A	9/1992	Apap et al.	5,474,472 A	12/1995	Niwa et al.
5,151,056 A	9/1992	McClune	5,475,922 A	12/1995	Tamura et al.
5,152,700 A	10/1992	Bogursky et al.	5,477,933 A	12/1995	Nguyen
5,161,987 A	11/1992	Sinisi	5,489,750 A	2/1996	Sakemi et al.
5,163,337 A	11/1992	Herron et al.	5,490,040 A	2/1996	Gavdenzi et al.
5,163,849 A	11/1992	Fogg et al.	5,491,303 A	2/1996	Weiss
5,167,528 A	12/1992	Nishiyama et al.	5,492,266 A	2/1996	Hoebener et al.
5,169,337 A	12/1992	Ortega et al.	5,495,668 A	3/1996	Furusawa et al.
5,174,770 A	12/1992	Sasaki et al.	5,496,183 A	3/1996	Soes et al.
5,181,855 A	1/1993	Mosquera et al.	5,498,167 A	3/1996	Seto et al.
5,194,480 A	3/1993	Block et al.	5,499,487 A	3/1996	McGill
5,199,885 A	4/1993	Korsunsky et al.	5,504,277 A	4/1996	Danner
5,203,075 A	4/1993	Angulas et al.	5,511,987 A	4/1996	Schinchi
5,207,372 A	5/1993	Funari et al.	5,512,519 A	4/1996	Hwang
5,213,868 A	5/1993	Liberty et al.	5,516,030 A	5/1996	Denton
5,214,308 A	5/1993	Nishiguchi	5,516,032 A	5/1996	Sakemi et al.
5,217,381 A	6/1993	Zell et al.	5,518,410 A	5/1996	Masami
5,222,649 A	6/1993	Funari et al.	5,519,580 A	5/1996	Natarajan et al.
5,224,867 A	7/1993	Ohtuski et al.	5,522,727 A	6/1996	Saito et al.
5,228,864 A	7/1993	Fusselman et al.	5,533,915 A	7/1996	Deans
5,229,016 A	7/1993	Hayes et al.	5,534,127 A	7/1996	Sakai
5,238,414 A	8/1993	Yaegashi et al.	5,539,153 A	7/1996	Schwiebert et al.
5,254,012 A	10/1993	Wang	5,542,174 A	8/1996	Chiu
5,255,839 A	10/1993	Da Costa Alves et al.	5,558,542 A	9/1996	O'Sullivan et al.
5,257,941 A	11/1993	Lwee et al.	5,564,952 A	10/1996	Davis et al.
5,261,155 A	11/1993	Angulas et al.	5,575,688 A	11/1996	Crane, Jr.
5,269,453 A	12/1993	Melton et al.	5,577,928 A	11/1996	Duclos
5,274,918 A *	1/1994	Reed H01R 29/00 264/263	5,580,283 A	12/1996	O'Sullivan et al.
5,275,330 A	1/1994	Isaacs et al.	5,586,908 A	12/1996	Lorrain
5,276,964 A	1/1994	Anderson, Jr. et al.	5,586,914 A	12/1996	Foster, Jr. et al.
5,277,624 A	1/1994	Champion et al.	5,588,859 A	12/1996	Maurice
5,284,287 A	2/1994	Wilson et al.	5,590,463 A	1/1997	Feldman et al.
5,285,163 A	2/1994	Liotta	5,591,118 A	1/1997	Bierck
5,286,212 A	2/1994	Broeksteeg	5,591,941 A	1/1997	Acocella et al.
5,288,949 A	2/1994	Crafts	5,593,322 A	1/1997	Swamy et al.
5,295,843 A	3/1994	Davis et al.	5,605,417 A	2/1997	Englert et al.
5,298,791 A	3/1994	Liberty et al.	5,609,502 A	3/1997	Thumma
5,302,135 A	4/1994	Lee	5,613,882 A	3/1997	Hnatuck et al.
5,321,582 A	6/1994	Casperson	5,618,187 A	4/1997	Goto
5,324,569 A	6/1994	Nagesh et al.	5,634,821 A	6/1997	Crane, Jr.
5,342,211 A	8/1994	Broeksteeg	5,637,008 A	6/1997	Kozel
5,344,327 A	9/1994	Brunker et al.	5,637,019 A	6/1997	Crane, Jr. et al.
5,346,118 A	9/1994	Degani et al.	5,643,009 A	7/1997	Dinkel et al.
5,354,219 A	10/1994	Wanjura	5,664,968 A	9/1997	Micklevicz
5,355,283 A	10/1994	Marrs et al.	5,664,973 A	9/1997	Emmert et al.
5,356,300 A	10/1994	Costello et al.	5,667,392 A	9/1997	Kocher et al.
5,356,301 A	10/1994	Champion et al.	5,672,064 A	9/1997	Provencher et al.
5,357,050 A	10/1994	Baran et al.	5,691,041 A	11/1997	Frankeny et al.
5,358,417 A	10/1994	Schmedding	D387,733 S	12/1997	Lee
5,377,902 A	1/1995	Hayes	5,697,799 A	12/1997	Consoli et al.
5,381,314 A	1/1995	Rudy, Jr. et al.	5,702,255 A	12/1997	Murphy et al.
5,382,168 A	1/1995	Azuma et al.	5,713,746 A	2/1998	Olson et al.
D355,409 S	2/1995	Krokaugger	5,718,606 A	2/1998	Rigby et al.
			5,727,963 A	3/1998	LeMaster
			5,730,609 A	3/1998	Harwath
			5,733,453 A	3/1998	DeBusk
			5,741,144 A	4/1998	Elco et al.
			5,741,161 A	4/1998	Cahaly et al.

(56)

References Cited

U.S. PATENT DOCUMENTS

5,742,484 A	4/1998	Gillette et al.	6,089,878 A	7/2000	Meng
5,743,009 A	4/1998	Matsui et al.	6,095,827 A	8/2000	Dutkowsky et al.
5,743,765 A	4/1998	Andrews et al.	6,113,418 A	9/2000	Kjelhahl
5,745,349 A	4/1998	Lemke	6,116,926 A	9/2000	Ortega et al.
5,746,608 A	5/1998	Taylor	6,116,965 A	9/2000	Arnett et al.
5,749,746 A	5/1998	Tan et al.	6,123,554 A	9/2000	Ortega et al.
5,755,595 A	5/1998	Davis et al.	6,125,535 A	10/2000	Chiou et al.
5,766,023 A	6/1998	Noschese et al.	6,129,592 A	10/2000	Mickievicz et al.
5,772,451 A	6/1998	Dozier, II et al.	6,132,255 A	10/2000	Verhoeven
5,782,644 A	7/1998	Kiat	6,139,336 A	10/2000	Olson
5,787,971 A	8/1998	Dodson	6,146,157 A	11/2000	Lenoir et al.
5,795,191 A	8/1998	Preputnick et al.	6,146,202 A	11/2000	Ramey et al.
5,810,607 A	9/1998	Shih et al.	6,146,203 A	11/2000	Elco et al.
5,817,973 A	10/1998	Elco et al.	6,152,747 A	11/2000	McNamara
5,827,094 A	10/1998	Aizawa et al.	6,152,756 A	11/2000	Huang et al.
5,831,314 A	11/1998	Wen	6,154,742 A	11/2000	Herriot
5,833,475 A	11/1998	Mitra	6,171,115 B1	1/2001	Mickievicz et al.
5,846,024 A	12/1998	Mao et al.	6,171,149 B1	1/2001	Van Zanten
5,851,121 A	12/1998	Thenaisie et al.	6,174,198 B1	1/2001	Wu et al.
5,853,797 A	12/1998	Fuchs et al.	6,179,663 B1	1/2001	Bradley et al.
5,857,857 A	1/1999	Fukuda	6,180,891 B1	1/2001	Murdeshwar
5,860,814 A	1/1999	Akama et al.	6,183,287 B1	2/2001	Po
5,860,816 A	1/1999	Provencher et al.	6,183,301 B1	2/2001	Paagman
5,871,362 A	2/1999	Campbell et al.	6,190,213 B1	2/2001	Reichart et al.
5,874,776 A	2/1999	Kresge et al.	6,193,537 B1	2/2001	Harper, Jr. et al.
5,876,219 A	3/1999	Taylor	6,196,871 B1	3/2001	Szu
5,876,222 A	3/1999	Gardner et al.	6,202,916 B1	3/2001	Updike et al.
5,876,248 A	3/1999	Brunker et al.	6,206,722 B1	3/2001	Ko et al.
5,882,214 A	3/1999	Hillbish et al.	6,206,735 B1	3/2001	Zanoli
5,883,782 A	3/1999	Thurston et al.	6,210,197 B1	4/2001	Yu
5,887,158 A	3/1999	Sample et al.	6,210,240 B1	4/2001	Comerci et al.
5,888,884 A	3/1999	Wojnarowski	6,212,755 B1	4/2001	Shimada et al.
5,892,791 A	4/1999	Moon	6,215,180 B1	4/2001	Chen et al.
5,893,761 A	4/1999	Longueville	6,219,913 B1	4/2001	Uchiyama
5,902,136 A	5/1999	Lemke et al.	6,220,884 B1	4/2001	Lin
5,904,581 A	5/1999	Pope et al.	6,220,895 B1	4/2001	Lin
5,908,333 A	6/1999	Perino et al.	6,220,896 B1	4/2001	Bertoncici et al.
5,913,702 A	6/1999	Garcin	6,227,882 B1	5/2001	Ortega et al.
5,919,050 A	7/1999	Kehley et al.	6,231,391 B1	5/2001	Ramey et al.
5,930,114 A	7/1999	Kuzmin et al.	6,234,851 B1	5/2001	Phillips
5,938,479 A	8/1999	Paulson et al.	6,238,225 B1	5/2001	Middlehurst et al.
5,943,770 A	8/1999	Thenaisie et al.	6,241,535 B1	6/2001	Lemke et al.
5,955,888 A	9/1999	Frederickson et al.	6,244,887 B1	6/2001	Commerci et al.
5,961,355 A	10/1999	Morlion et al.	6,257,478 B1	7/2001	Straub
5,967,844 A	10/1999	Doutrich et al.	6,259,039 B1	7/2001	Chronos, Jr. et al.
5,971,817 A	10/1999	Longueville	6,261,132 B1	7/2001	Koseki et al.
5,975,921 A	11/1999	Shuey	6,267,604 B1	7/2001	Mickievicz et al.
5,980,270 A	11/1999	Fjelstad et al.	6,269,539 B1	8/2001	Takahashi et al.
5,980,321 A	11/1999	Cohen et al.	6,274,474 B1	8/2001	Caletka et al.
5,982,249 A	11/1999	Bruns	6,280,209 B1	8/2001	Bassler et al.
5,984,690 A	11/1999	Riechelmann et al.	6,280,230 B1	8/2001	Takase et al.
5,984,726 A	11/1999	Wu	6,280,809 B1	8/2001	Wang
5,992,953 A	11/1999	Rabinovitz	6,290,552 B1	9/2001	Saito et al.
5,993,259 A	11/1999	Stokoe et al.	6,293,827 B1	9/2001	Stokoe et al.
6,012,948 A	1/2000	Wu	6,299,483 B1	10/2001	Cohen et al.
6,022,227 A	2/2000	Huang	6,299,484 B2	10/2001	Van Woensel et al.
6,024,584 A	2/2000	Lemke et al.	6,299,492 B1	10/2001	Pierini et al.
6,027,381 A	2/2000	Lok	6,302,711 B1	10/2001	Ito
6,036,549 A	3/2000	Wulff	6,309,245 B1	10/2001	Sweeney
6,041,498 A	3/2000	Hillbish et al.	6,319,075 B1	11/2001	Clark et al.
6,042,389 A	3/2000	Lemke et al.	6,322,377 B2	11/2001	Middlehurst et al.
6,042,394 A	3/2000	Mitra et al.	6,322,379 B1	11/2001	Ortega et al.
6,042,427 A	3/2000	Adriaenssens et al.	6,322,393 B1	11/2001	Doutrich et al.
6,048,213 A	4/2000	Lai et al.	6,328,602 B1	12/2001	Yamasaki et al.
6,050,842 A	4/2000	Ferrill et al.	6,338,635 B1	1/2002	Lee
6,050,862 A	4/2000	Ishii	6,343,955 B2	2/2002	Billman et al.
6,053,751 A	4/2000	Humphrey	6,347,952 B1	2/2002	Hasegawa et al.
6,059,170 A	5/2000	Jimarez et al.	6,347,962 B1	2/2002	Kline
6,066,048 A	5/2000	Lees	6,350,134 B1	2/2002	Fogg et al.
6,068,518 A	5/2000	McEuen	6,354,877 B1	3/2002	Shuey et al.
6,068,520 A	5/2000	Winings et al.	6,358,061 B1	3/2002	Regnier
6,071,152 A	6/2000	Achammer et al.	6,359,783 B1	3/2002	Noble
6,077,130 A	6/2000	Hughes et al.	6,360,940 B1	3/2002	Bolde et al.
6,083,047 A	7/2000	Paagman	6,361,366 B1	3/2002	Shuey et al.
6,086,386 A	7/2000	Fjelstad et al.	6,361,376 B1	3/2002	Onoda
			6,362,961 B1	3/2002	Chiou
			6,363,607 B1	4/2002	Chen et al.
			6,364,710 B1	4/2002	Billman et al.
			6,371,773 B1	4/2002	Crofoot et al.

(56)

References Cited

U.S. PATENT DOCUMENTS

6,371,813	B2	4/2002	Ramey et al.	6,672,884	B1	1/2004	Toh et al.
6,375,478	B1	4/2002	Kikuchi	6,672,907	B2	1/2004	Azuma
6,375,508	B1	4/2002	Pickles et al.	6,679,709	B2	1/2004	Takeuchi
6,379,188	B1	4/2002	Cohen et al.	6,692,272	B2	2/2004	Lemke et al.
6,386,914	B1	5/2002	Collins et al.	6,695,627	B2	2/2004	Ortega et al.
6,386,924	B2	5/2002	Long	6,702,590	B2	3/2004	Zaderej et al.
6,390,826	B1	5/2002	Affolter et al.	6,702,594	B2	3/2004	Lee et al.
6,394,818	B1	5/2002	Smalley, Jr.	6,705,902	B1	3/2004	Yi et al.
6,402,566	B1	6/2002	Middlehurst et al.	6,709,294	B1	3/2004	Cohen et al.
6,409,543	B1	6/2002	Astbury, Jr. et al.	6,712,621	B2	3/2004	Li et al.
6,414,248	B1	7/2002	Sundstrom	6,712,646	B2	3/2004	Shindo
6,420,778	B1	7/2002	Sinyansky	6,716,045	B2	4/2004	Meredith
6,425,785	B1	7/2002	Azuma	6,716,068	B2	4/2004	Wu
6,428,328	B2	8/2002	Haba et al.	6,717,825	B2	4/2004	Volstorf
6,431,914	B1	8/2002	Billman	6,726,492	B1	4/2004	Yu
6,431,921	B2	8/2002	Saito et al.	6,736,664	B2	5/2004	Ueda et al.
6,435,914	B1	8/2002	Billman	6,739,910	B1	5/2004	Wu
6,450,829	B1	9/2002	Weisz-Margulescu	6,740,820	B2	5/2004	Cheng
6,457,983	B1	10/2002	Bassler et al.	D492,295	S	6/2004	Glatt
6,461,183	B1	10/2002	Ohkita et al.	6,743,037	B2	6/2004	Kassa et al.
6,461,202	B2	10/2002	Kline	6,743,059	B1	6/2004	Korsunsky et al.
6,464,529	B1	10/2002	Jensen et al.	6,746,278	B2	6/2004	Nelson et al.
6,471,523	B1	10/2002	Shuey	6,749,439	B1	6/2004	Potter et al.
6,471,548	B2	10/2002	Bertoncini et al.	6,762,067	B1	7/2004	Quinones et al.
6,472,474	B2	10/2002	Burkhardt et al.	6,764,341	B2	7/2004	Lappoehn
6,482,038	B2	11/2002	Olson	6,769,883	B2	8/2004	Brid et al.
6,485,330	B1	11/2002	Doutrich	6,769,935	B2	8/2004	Stokoe et al.
6,488,549	B1	12/2002	Weller et al.	6,776,635	B2	8/2004	Blanchfield et al.
6,489,567	B2	12/2002	Zachrai	6,776,649	B2	8/2004	Pape et al.
6,491,545	B1	12/2002	Spiegel et al.	6,780,027	B2	8/2004	Allison et al.
6,494,734	B1	12/2002	Shuey	6,786,771	B2	9/2004	Gailus
6,503,103	B1	1/2003	Cohen et al.	6,790,088	B2	9/2004	Ono et al.
6,506,076	B2	1/2003	Cohen et al.	6,796,831	B1	9/2004	Yasufuku et al.
6,506,081	B2	1/2003	Blanchfield et al.	6,797,215	B2	9/2004	Bonk et al.
6,514,103	B2	2/2003	Pape et al.	D497,343	S	10/2004	Busse et al.
6,517,360	B1	2/2003	Cohen	6,805,278	B1	10/2004	Olson et al.
6,520,803	B1	2/2003	Dunn	6,808,399	B2	10/2004	Rothermel et al.
6,526,519	B1	2/2003	Cuthbert	6,808,420	B2	10/2004	Whiteman, Jr. et al.
6,527,587	B1	3/2003	Ortega et al.	6,810,783	B1	11/2004	Larose
6,527,588	B2	3/2003	Paagman	6,811,440	B1	11/2004	Rothermel et al.
6,528,737	B1	3/2003	Kwong et al.	6,814,590	B2	11/2004	Minich et al.
6,530,134	B1	3/2003	Laphan et al.	6,814,619	B1	11/2004	Stokoe et al.
6,537,086	B1	3/2003	Mac Mullin	6,824,391	B2	11/2004	Mickiewicz et al.
6,537,111	B2	3/2003	Brammer et al.	6,829,143	B2	12/2004	Russell et al.
6,540,522	B2	4/2003	Sipe	6,835,072	B2	12/2004	Simons et al.
6,540,558	B1	4/2003	Paagman	6,835,103	B2	12/2004	Middlehurst et al.
6,540,559	B1	4/2003	Kemmick et al.	6,843,686	B2	1/2005	Ohnishi et al.
6,544,046	B1	4/2003	Hahn et al.	6,843,687	B2	1/2005	McGowan et al.
6,544,072	B2	4/2003	Olson	6,846,202	B1	1/2005	Schmidt et al.
6,547,066	B2	4/2003	Koch	6,848,886	B2	2/2005	Schmaling et al.
6,551,112	B1	4/2003	Li et al.	6,848,944	B2	2/2005	Evans
6,551,140	B2	4/2003	Billman et al.	6,848,950	B2	2/2005	Allison et al.
6,554,647	B1	4/2003	Cohen et al.	6,848,953	B2	2/2005	Schell et al.
6,565,387	B2	5/2003	Cohen	6,851,974	B2	2/2005	Doutrich
6,565,388	B1	5/2003	Van Woensel et al.	6,851,980	B2	2/2005	Nelson et al.
6,572,409	B2	6/2003	Nitta et al.	6,852,567	B1	2/2005	Lee et al.
6,572,410	B1	6/2003	Volstorf et al.	D502,919	S	3/2005	Studnick, III
6,575,774	B2	6/2003	Ling et al.	6,866,549	B2	3/2005	Kimura et al.
6,575,776	B1	6/2003	Conner et al.	6,869,292	B2	3/2005	Johnescu et al.
6,589,071	B1	7/2003	Lias et al.	6,869,294	B2	3/2005	Clark et al.
6,592,381	B2	7/2003	Cohen et al.	6,872,085	B1	3/2005	Cohen et al.
6,602,095	B2	8/2003	Astbury, Jr. et al.	6,884,117	B2	4/2005	Korsunsky et al.
6,604,967	B2	8/2003	Middlehurst et al.	6,890,184	B2	5/2005	Doblar et al.
6,607,402	B2	8/2003	Cohen et al.	6,890,214	B2	5/2005	Brown et al.
6,623,310	B1	9/2003	Billman et al.	6,890,221	B2	5/2005	Wagner
6,629,854	B2	10/2003	Murakami	6,893,272	B2	5/2005	Yu
6,633,490	B2	10/2003	Centola et al.	6,893,300	B2	5/2005	Zhou et al.
6,641,410	B2	11/2003	Marvin et al.	6,893,686	B2	5/2005	Egan
6,641,411	B1	11/2003	Stoddard et al.	6,899,566	B2	5/2005	Kline et al.
6,641,825	B2	11/2003	Scholz et al.	6,902,411	B2	6/2005	Kubo
6,652,318	B1	11/2003	Winings et al.	6,905,367	B2	6/2005	Crane, Jr. et al.
6,663,426	B2	12/2003	Hasircoglu et al.	6,913,490	B2	7/2005	Whiteman, Jr. et al.
6,665,189	B1	12/2003	Lebo	6,918,776	B2	7/2005	Spink, Jr.
6,666,693	B2	12/2003	Belopolsky et al.	6,918,789	B2	7/2005	Lang et al.
6,669,514	B2	12/2003	Weibking et al.	6,929,504	B2	8/2005	Ling et al.
				6,932,649	B1	8/2005	Rothermel et al.
				6,939,173	B1	9/2005	Elco et al.
				6,945,796	B2	9/2005	Bassler et al.
				6,947,012	B2	9/2005	Aisenbrey

(56)

References Cited

U.S. PATENT DOCUMENTS

6,951,466 B2	10/2005	Sandoval et al.	7,384,311 B2	6/2008	Sharf et al.
6,953,351 B2	10/2005	Fromm et al.	7,402,064 B2	7/2008	Daily
6,969,268 B2	11/2005	Brunker	7,407,387 B2	8/2008	Johnescu
6,969,280 B2	11/2005	Chien et al.	7,422,483 B2	9/2008	Avery et al.
6,975,511 B1	12/2005	Lebo et al.	7,425,145 B2	9/2008	Ngo et al.
6,976,886 B2	12/2005	Winings et al.	7,429,176 B2	9/2008	Johnescu
6,979,202 B2	12/2005	Benham et al.	7,442,054 B2	10/2008	Minich et al.
6,979,215 B2	12/2005	Avery et al.	7,445,457 B1	11/2008	Frangioso, Jr. et al.
6,981,883 B2	1/2006	Raistrick et al.	7,452,242 B2	11/2008	Poh et al.
6,988,902 B2	1/2006	Winings et al.	7,452,249 B2	11/2008	Daily
6,994,569 B2	2/2006	Minich et al.	7,458,839 B2	12/2008	Ngo
7,001,189 B1	2/2006	McGowan et al.	7,467,955 B2	12/2008	Raistrick et al.
7,021,975 B2	4/2006	Lappohn	7,476,108 B2	1/2009	Swain
7,040,901 B2	5/2006	Benham et al.	7,497,735 B2	3/2009	Belopolsky
7,044,794 B2	5/2006	Consoli et al.	7,497,736 B2	3/2009	Minich et al.
7,059,892 B1	6/2006	Trout	7,500,871 B2	3/2009	Minich et al.
7,059,919 B2	6/2006	Clark et al.	7,503,804 B2	3/2009	Minich
7,065,871 B2	6/2006	Minich et al.	7,541,135 B2	6/2009	Swain
7,070,464 B2	7/2006	Clark et al.	7,549,897 B2	6/2009	Fedder et al.
7,074,096 B2	7/2006	Copper et al.	7,553,182 B2	6/2009	Buck et al.
7,086,147 B2	8/2006	Caletka et al.	7,588,463 B2	9/2009	Yamada et al.
7,090,501 B1	8/2006	Scherer et al.	7,621,781 B2	11/2009	Rothermel et al.
7,094,102 B2	8/2006	Cohen et al.	D607,822 S	1/2010	Dennes
7,097,465 B1	8/2006	Korsunsky et al.	D611,908 S	3/2010	Takada et al.
7,097,506 B2	8/2006	Nakada	7,682,193 B2	3/2010	Stoner
7,101,191 B2	9/2006	Benham et al.	7,708,569 B2	5/2010	Sercu et al.
7,101,228 B2	9/2006	Hammer et al.	D618,180 S	6/2010	Gross et al.
7,104,812 B1	9/2006	Bogiel et al.	D618,181 S	6/2010	Gross et al.
7,108,556 B2	9/2006	Cohen et al.	7,753,731 B2	7/2010	Cohen et al.
7,114,963 B2	10/2006	Shuey et al.	7,762,843 B2	7/2010	Minich et al.
7,114,964 B2	10/2006	Winings et al.	7,794,278 B2	9/2010	Cohen et al.
7,118,391 B2	10/2006	Minich et al.	D626,075 S	10/2010	Truskett et al.
RE39,380 E	11/2006	Davis	7,833,065 B2	11/2010	Lin et al.
7,131,870 B2	11/2006	Whiteman, Jr. et al.	D628,963 S	12/2010	Sau et al.
7,137,848 B1	11/2006	Trout et al.	7,883,366 B2	2/2011	Davis et al.
7,153,162 B2	12/2006	Mizumura et al.	7,931,474 B2	4/2011	Laurx et al.
7,160,151 B1	1/2007	Rigby et al.	7,976,326 B2	7/2011	Stoner
7,163,421 B1	1/2007	Cohen et al.	7,988,456 B2	8/2011	Davis et al.
7,168,963 B2	1/2007	Minich et al.	8,011,957 B2	9/2011	Pan
7,172,461 B2	2/2007	Davis et al.	D651,177 S	12/2011	Luo
7,182,608 B2	2/2007	Soh et al.	8,079,847 B2	12/2011	Davis et al.
7,182,642 B2	2/2007	Ngo et al.	D653,621 S	2/2012	Gross et al.
7,182,643 B2	2/2007	Winings et al.	8,109,770 B2	2/2012	Perugini et al.
7,195,497 B2	3/2007	Hull et al.	8,119,926 B2	2/2012	Murphy
D540,258 S	4/2007	Peng et al.	8,157,599 B2	4/2012	Wei
7,204,699 B2	4/2007	Stoner	8,231,415 B2	7/2012	Johnescu et al.
7,207,807 B2	4/2007	Fogg	8,267,721 B2	9/2012	Minich
D541,748 S	5/2007	Peng et al.	8,277,241 B2	10/2012	Horchler et al.
D542,736 S	5/2007	Riku	8,366,485 B2	2/2013	Johnescu
7,220,141 B2	5/2007	Daily et al.	8,374,470 B2	2/2013	Ban et al.
7,239,526 B1	7/2007	Bibee	8,408,939 B2	4/2013	Davis et al.
7,241,168 B2	7/2007	Sakurai et al.	8,414,199 B2	4/2013	Ishigami
7,258,562 B2	8/2007	Daily et al.	8,465,213 B2	6/2013	Tamura et al.
D550,158 S	9/2007	Victor	8,480,413 B2	7/2013	Minich et al.
D550,628 S	9/2007	Whiteman, Jr. et al.	RE44,556 E	10/2013	Minich
7,267,515 B2	9/2007	Lappohn	8,550,861 B2	10/2013	Cohen et al.
7,270,574 B1	9/2007	Ngo	8,632,263 B2	1/2014	Nekado et al.
7,273,382 B2	9/2007	Igarashi et al.	D712,843 S	9/2014	Buck et al.
7,278,856 B2	10/2007	Minich	D714,227 S	9/2014	Buck et al.
7,281,950 B2	10/2007	Belopolsky	8,864,521 B2	10/2014	Atkinson et al.
D554,591 S	11/2007	Victor	D718,253 S *	11/2014	Zerebilov D13/154
7,292,055 B2	11/2007	Egitto	8,888,529 B2	11/2014	Buck et al.
7,303,427 B2	12/2007	Swain	D720,698 S	1/2015	Zerebilov et al.
7,309,239 B2	12/2007	Shuey et al.	8,944,831 B2	2/2015	Stoner et al.
7,316,585 B2	1/2008	Smith et al.	D727,268 S	4/2015	Buck et al.
7,322,855 B2	1/2008	Mongold et al.	8,998,645 B2	4/2015	Vanaleck et al.
7,322,856 B2	1/2008	Laurx et al.	D737,210 S	8/2015	Pao
7,331,802 B2	2/2008	Rothermel et al.	D738,314 S	9/2015	Buck et al.
7,335,043 B2	2/2008	Ngo et al.	D748,063 S *	1/2016	Buck D13/154
7,338,321 B2	3/2008	Laurx	D750,030 S *	2/2016	Zerebilov D13/154
7,344,383 B1	3/2008	Lu et al.	2001/0003685 A1	6/2001	Aritani
7,347,740 B2	3/2008	Minich	2001/0008189 A1	7/2001	Reede
7,351,071 B2	4/2008	Korsunsky et al.	2001/0012729 A1	8/2001	Van Woensel
7,381,092 B2	6/2008	Nakada	2001/0041477 A1	11/2001	Billman et al.
7,384,289 B2	6/2008	Minich	2001/0046810 A1	11/2001	Cohen et al.
			2001/0046816 A1	11/2001	Saito et al.
			2002/0013101 A1	1/2002	Long
			2002/0039857 A1	4/2002	Naito et al.
			2002/0084105 A1	7/2002	Geng et al.

(56)

References Cited

U.S. PATENT DOCUMENTS

2002/0098727 A1 7/2002 McNamara et al.
 2002/0106930 A1 8/2002 Pape et al.
 2002/0106932 A1 8/2002 Holland et al.
 2002/0111068 A1 8/2002 Cohen et al.
 2002/0127903 A1 9/2002 Billman et al.
 2002/0142629 A1 10/2002 Zaderej et al.
 2002/0142676 A1 10/2002 Hosaka et al.
 2002/0159235 A1 10/2002 Miller et al.
 2002/0173177 A1 11/2002 Korsunsky
 2002/0187688 A1 12/2002 Marvin et al.
 2002/0193019 A1 12/2002 Blanchfield et al.
 2003/0116857 A1 6/2003 Taniguchi et al.
 2003/0119378 A1 6/2003 Avery
 2003/0143894 A1 7/2003 Kline et al.
 2003/0171010 A1 9/2003 Winings et al.
 2003/0203665 A1 10/2003 Ohnishi et al.
 2003/0219999 A1 11/2003 Minich et al.
 2003/0220021 A1 11/2003 Whiteman, Jr. et al.
 2003/0236035 A1 12/2003 Kuroda et al.
 2004/0018757 A1 1/2004 Lang et al.
 2004/0038590 A1 2/2004 Lang et al.
 2004/0072470 A1 4/2004 Lang et al.
 2004/0077224 A1 4/2004 Marchese
 2004/0087196 A1 5/2004 Lang et al.
 2004/0114866 A1 6/2004 Hiramatsu
 2004/0157477 A1 8/2004 Johnson et al.
 2004/0224559 A1 11/2004 Nelson et al.
 2004/0235321 A1 11/2004 Mizumura et al.
 2004/0259420 A1 12/2004 Wu
 2005/0009402 A1 1/2005 Chien et al.
 2005/0026503 A1 2/2005 Trout et al.
 2005/0032401 A1 2/2005 Kobayashi
 2005/0048838 A1 3/2005 Korsunsky et al.
 2005/0079763 A1 4/2005 Lemke et al.
 2005/0101166 A1 5/2005 Kameyama
 2005/0101188 A1 5/2005 Benham et al.
 2005/0112952 A1 5/2005 Wang et al.
 2005/0118869 A1 6/2005 Evans
 2005/0170700 A1 8/2005 Shuey et al.
 2005/0196987 A1 9/2005 Shuey et al.
 2005/0202722 A1 9/2005 Regnier et al.
 2005/0215121 A1 9/2005 Tokunaga
 2005/0227552 A1 10/2005 Yamashita et al.
 2005/0277315 A1 12/2005 Mongold et al.
 2005/0287869 A1 12/2005 Kenny et al.
 2006/0003620 A1 1/2006 Daily et al.
 2006/0014433 A1 1/2006 Consoli et al.
 2006/0024983 A1 2/2006 Cohen et al.
 2006/0024984 A1 2/2006 Cohen et al.
 2006/0046526 A1 3/2006 Minich
 2006/0051987 A1 3/2006 Goodman et al.
 2006/0068610 A1 3/2006 Belopolsky
 2006/0068641 A1 3/2006 Hull et al.
 2006/0073709 A1 4/2006 Reid
 2006/0116857 A1 6/2006 Sevic et al.
 2006/0121749 A1 6/2006 Fogg
 2006/0128197 A1 6/2006 McGowan et al.
 2006/0141818 A1 6/2006 Ngo
 2006/0183377 A1 8/2006 Sinsheimer
 2006/0192274 A1 8/2006 Lee et al.
 2006/0216969 A1 9/2006 Bright et al.
 2006/0228912 A1 10/2006 Morlion et al.
 2006/0232301 A1 10/2006 Morlion et al.
 2006/0281354 A1 12/2006 Ngo et al.
 2007/0004287 A1 1/2007 Marshall
 2007/0021002 A1 1/2007 Laurx et al.
 2007/0042639 A1 2/2007 Manter et al.
 2007/0071391 A1 3/2007 Mazotti et al.
 2007/0099455 A1 5/2007 Rothermel et al.
 2007/0099512 A1 5/2007 Sato
 2007/0183707 A1 8/2007 Umezawa
 2007/0183724 A1 8/2007 Sato
 2007/0190825 A1 8/2007 Shuey et al.
 2007/0202715 A1 8/2007 Daily et al.
 2007/0202747 A1 8/2007 Sharf et al.

2007/0205774 A1 9/2007 Minich
 2007/0207641 A1 9/2007 Minich
 2007/0293084 A1 12/2007 Ngo
 2008/0032524 A1 2/2008 Lemke et al.
 2008/0045079 A1 2/2008 Minich et al.
 2008/0176453 A1 7/2008 Minich et al.
 2008/0232737 A1 9/2008 Ishigami et al.
 2008/0246555 A1 10/2008 Kirk et al.
 2008/0248670 A1 10/2008 Daily et al.
 2008/0316729 A1 12/2008 Rothermel et al.
 2009/0011643 A1 1/2009 Amleshi et al.
 2010/0055983 A1 3/2010 Wu
 2010/0093209 A1 5/2010 Liu et al.
 2010/0197149 A1 8/2010 Davis et al.
 2010/0216342 A1 8/2010 Lin
 2010/0221959 A1 9/2010 Pan
 2010/0240233 A1 9/2010 Johnescu et al.
 2010/0291803 A1 11/2010 Kirk
 2011/0097934 A1 4/2011 Minich
 2011/0159744 A1 6/2011 Buck
 2011/0195593 A1 8/2011 McGrath et al.
 2012/0202363 A1 8/2012 McNamara et al.
 2012/0214343 A1 8/2012 Buck et al.
 2012/0289095 A1 11/2012 Kirk
 2013/0005160 A1 1/2013 Minich
 2013/0090025 A1 4/2013 Trout et al.
 2013/0122744 A1 5/2013 Morgan et al.
 2013/0149881 A1 6/2013 Johnsecu et al.
 2013/0149890 A1 6/2013 Schroll et al.
 2013/0195408 A1 8/2013 Hermeline et al.
 2013/0210246 A1 8/2013 Davis et al.
 2013/0273756 A1 10/2013 Stoner et al.
 2013/0273781 A1 10/2013 Buck et al.
 2014/0017957 A1 1/2014 Horchler et al.
 2014/0227911 A1 8/2014 Lim et al.

FOREIGN PATENT DOCUMENTS

DE 3605316 8/1987
 DE 4040551 4/1993
 DE 10226279 11/2003
 DE 102010005001 8/2010
 EP 0212764 3/1987
 EP 0273683 7/1988
 EP 0337634 10/1989
 EP 0442785 8/1991
 EP 0486298 5/1992
 EP 0321257 4/1993
 EP 0560550 9/1993
 EP 0562691 9/1993
 EP 0591772 4/1994
 EP 0623248 11/1995
 EP 0706240 4/1996
 EP 0782220 7/1997
 EP 0789422 8/1997
 EP 0843383 5/1998
 EP 0635910 6/2000
 EP 1024556 8/2000
 EP 1111730 6/2001
 EP 0891016 10/2002
 EP 1091449 9/2004
 EP 1148587 4/2005
 GB 1162705 8/1969
 JP 57/058115 4/1982
 JP 60/072663 4/1985
 JP 02/278893 11/1990
 JP 0521119 1/1993
 JP 05344728 12/1993
 JP 0668943 3/1994
 JP 06236788 8/1994
 JP 07114958 5/1995
 JP 07169523 7/1995
 JP 0896918 4/1996
 JP 08125379 5/1996
 JP 09199215 7/1997
 JP 11185886 7/1999
 JP 2000/003743 1/2000
 JP 2000/003744 1/2000
 JP 2000/003745 1/2000

(56)

References Cited

FOREIGN PATENT DOCUMENTS

JP	2000/003746	1/2000
JP	2000/228243	8/2000
JP	2001/135388	5/2001
JP	2001/305182	10/2001
JP	2002/008790	1/2002
JP	2003/217785	7/2003
JP	2007/128706	5/2007
KR	100517561	9/2005
TW	576555	8/1990
TW	546872	8/2003
WO	WO 90/16093	12/1990
WO	WO 96/38889	12/1996
WO	WO 96/42123	12/1996
WO	WO 97/20454	6/1997
WO	WO 97/43885	11/1997
WO	WO 97/44859	11/1997
WO	WO 97/45896	12/1997
WO	WO 98/15989	4/1998
WO	WO 00/16445	3/2000
WO	WO 01/29931	4/2001
WO	WO 01/39332	5/2001
WO	WO 02/058191	7/2002
WO	WO 02/101882	12/2002
WO	WO 02/103847	12/2002
WO	WO 2005/065254	7/2005
WO	WO 2006/031296	3/2006
WO	WO 2006/105535	10/2006
WO	WO 2007/064632	6/2007
WO	WO 2008/082548	7/2008
WO	WO 2008/117180	10/2008
WO	WO 2012/047619	4/2012
WO	WO 2012/174120	12/2012

OTHER PUBLICATIONS

U.S. Appl. No. 29/418,310, filed Apr. 13, 2012, Buck et al.
 U.S. Appl. No. 29/426,921, filed Jul. 11, 2012, Horchler.
 U.S. Appl. No. 29/444,125, filed Jan. 25, 2013, Harper, Jr. et al.
 U.S. Appl. No. 29/449,794, filed Mar. 15, 2013, Zerebilov et al.
 U.S. Appl. No. 29/504,778, filed Oct. 9, 2014, Horchler.
 U.S. Appl. No. 29/517,389, filed Feb. 12, 2015, Buck et al.
 U.S. Appl. No. 29/549,273, filed Dec. 21, 2015, Buck et al.
 "1.0 HDMI Right Angle Header Assembly (19 Pin) Lead Free", Molex Incorporated, Jul. 20, 2004, 7 pages.
 "1.90 by 1.35mm (.075 by .053) Pitch Impact, Backplane Connector System 3 and 4 Pair, Features and Specification", Molex, www.molex.com/link/Impact.html, 2008, 5 pages.
 "4.0 UHD Connector Differential Signal Crosstalk, Reflections", 1998, p. 8-9.
 Ahn et al., "A Design of the Low-Pass Filter Using the Novel Microstrip Defected Ground Structure", IEEE Transactions on Microwave Theory and Techniques, 2001, 49(1), 86-93.
 "AMP Z-Dok and Z-Dok and Connectors", Tyco Electronics/AMP, Application Specification #114-13068, Aug. 30, 2005, 17 pages.
 "AMP Z-Pack 2mm HM Connector, 2mm Centerline, Eight-Row, Right-Angle Applications", Electrical Performance Report, EPR 889065, Issued Sep. 1998, 59 pages.
 "AMP Z-Pack 2mm HM Interconnection System", 1992/1994, AMP Incorporated, 6 pages.
 "AMP Z-Pack HM-Zd Performance at Gigabit Speeds", Tyco Electronics, Report #20GC014, Rev.B., May 4, 2001, 32 pages.
 "B. Bandwidth and Rise Time Budgets, Module 1-8 Fiber Optic Telecommunications (E-XVI-2a)", http://cord.org-step_online-st1-8-st18exvi2a.htm, 2006, 1-3.
 "Backplane Connectors", http://www.amphenol-tcs.com/products/connectors/backplane/index.html, Amphenol TCS (ATCS), Jun. 19, 2008, 1-3.
 Berg Electronics Catalog, p. 13-96, Solder Washers, 1996, 1 page.
 "Champ Z-Dok Connector System", Tyco Electronics, Jan. 2002, 3 pages.

Chen et al., "Characteristics of Coplanar Transmission Lines on Multilayer Substrates: Modeling and Experiments", IEEE Transactions on Microwave Theory and Techniques, Jun. 1997, 45(6), 939-945.
 Cheng et al., "Terahertz-Bandwidth Characteristics of Coplanar Transmission Lines on Low Permittivity Substrates", IEEE Transactions on Microwave Theory and Techniques, 1994, 42(12), 2399-2406.
 Chua et al., "Broadband Characterisation of CPW Transition and Transmission Line Parameters for Small Reflection Up to 100 GHz", RF and Microwave Conference, 2004, 269-271.
 "Daughtercard Hole Pattern: Signal Modules (10 & 25 positions) Connector Assembly", Customer No. C-163-5101-500, Teradyne Connection Systems, Inc., 2001, 1 page.
 Derman "Speed, Density Push Design Complexities," Electronic Engineering Times, May 1998, 2 pages.
 European Patent Application No. 12305119.5: European Search Report dated Jul. 11, 2012, 5 pages.
 European Patent Application No. 10753953.8: Extended European Search Report dated Nov. 7, 2013, 6 pages.
 "FCI's Airmax VS Connector System Honored at DesignCon 2005", http://www.heilind.com-products-fci-airmax-vs-design.asp, Heilind Electronics, Inc., 2005, 1 page.
 Finan, "Thermally Conductive Thermoplastics", LNP Engineering Plastics, Inc., Plastics Engineering 2000, www.4spe.org, 4 pages.
 "Framatome Connector Specification", May 10, 1999, 1 page.
 Fusi et al., "Differential Signal Transmission through Backplanes and Connectors", Electronic Packaging and Production, Mar. 1996, 27-31.
 "GbXI-Trac Backplane Connector System", www.molex.com/cgi-bin, Molex, 2007, 1-3.
 "Gig-Array Connector System, Board to Board Connectors", 2005, 4 pages.
 "Gig-Array High Speed Mezzanine Connectors 15-40 mm Board to Board", FCI Corporation, Jun. 5, 2006, 1 page.
 Goel et al., "AMP Z-Pack Interconnect System", AMP Incorporated, 1990, 9 pages.
 "HDM Separable Interface Detail", Molex, Feb. 17, 1993, 3 pages.
 "HDM Stacker Signal Integrity", http://www.teradyne.com/prods/tcs/products/connectors/mezzanine/hdm_stacker/signintegrity.html, Amphenol TCS (ATCS), Feb. 2, 2006, 3 pages.
 "HDM, HDM Plus Connectors", http://www.teradyne.com-prods-tcs-products-connectors-backplane-hdm-index.html, Amphenol TCS, 2006, 1 page.
 "HDM/HDM Plus, 2mm, Backplane Interconnection System", Teradyne Connection Systems, 1993, 22 pages.
 Hettak et al., "Simultaneous Realization of Millimeter Wave Uniplanar Shunt Stubs and DC Block", IEEE MTT-S Digest, 1998, 809-812.
 "High Definition Multimedia Interface (HDMI)", www.molex.com, Molex, Jun. 19, 2008, 2 pages.
 "High Speed Backplane Interconnect Solutions", Tyco Electronics, 2007, 6 pages.
 "High Speed Characterization Report, SEAM-30-02.0-S-10-2", www.samtec.com, SAMTEC, 2005, 55 pages.
 "Honda High-Speed Backplane Connector NSP Series", Honda Connectors, Feb. 7, 2003, 25 pages.
 Hult, "FCI's Problem Solving Approach Changes Market, The FCI Electronics AirMax VS", http://www.connectorupplier.com-tech_updates_FCI-Airmax_archive.htm, ConnectorSupplier.com, 2006, 1-4.
 Hunsaker, "Ventura Application Design", TB-2127, Amphenol, Aug. 25, 2005, 13 pages.
 IBM Technical Disclosure Bulletin, 1972, 14(8), 2 pages.
 IBM Technical Disclosure Bulletin, 1977, 20(2), 2 pages.
 IBM Technical Disclosure Bulletin, 1990, 32(11), 2 pages.
 "Impact 3 Pair 10 Column Signal Module", Tyco Electronics, Mar. 25, 2008, 1 page.
 "Impact 3 Pair Header Unguided Open Assembly", Tyco Electronics, Apr. 11, 2008, 1 page.
 "Impact Connector Offered by Tyco Electronic, High Speed Backplane Connector System", Tyco Electronics, Apr. 15, 2008, 12 pages.

(56)

References Cited

OTHER PUBLICATIONS

- International Application No. PCT/US2003/014370, International Search Report dated Aug. 6, 2003, 2 pages.
- International Application No. PCT/US2010/040899, International Search Report dated Jan. 25, 2011, 2 pages.
- International Patent Application No. PCT/US2013/035775: International Search Report dated Jul. 18, 2013, 3 pages.
- International Patent Application No. PCT/US2013/035915: International Search Report and Written Opinion dated Jul. 25, 2013, 17 pages.
- International Patent Application No. PCT/US2013/049995: International Search Report dated Oct. 28, 2013, 18 pages.
- Kazmierowicz, "Profiling Your Solder Reflow Oven in Three Passes or Less", KIC Oven Profiling, Surface Mount Technology, 1990, 2 pages.
- Kazmierowicz, "The Science Behind Conveyor Oven Thermal Profiling", KIC Oven Profiling, Surface Mount Technology, 1990, 9 pages.
- Lee et al., "Characteristic of the Coplanar Waveguide to Microstrip Right-Angled Transition", Department of Electronics Engineering, 1998, 3 pages.
- Leung et al., "Low-Loss Coplanar Waveguides Interconnects on Low-Resistivity Silicon Substrate", IEEE Transactions on Components and Packaging Technologies, 2004, 27(3), 507-512.
- Lim et al., "A Spiral-Shaped Defected Ground Structure for Coplanar Waveguide", IEEE Microwave and Wireless Components Letters, 2002, 12(9), 330-332.
- "Lucent Technologies' Bell Labs and FCI Demonstrate 25gb-S Data Transmission Over Electrical Backplane Connectors", <http://www.lucintel.com-press-0205-050201.bla.html>, Lucent Tech Bell Labs, Feb. 1, 2005, 1-4.
- Machac et al., "Space Leakage of Power from Uniplanar Transmission Lines", Czech Technical University, 565-568.
- Mao et al., "Characterization of Coplanar Waveguide Open End Capacitance-Theory and Experiment", IEEE Transactions on Microwave Theory and Techniques, 1994, 42(6), 1016-1024.
- "Metral 1000 Series, 5 Row Receptacle, Right Angle, Press Fit, PCB Mounted Receptacle Assembly", FCI 2001, 1 page.
- "Metral 2mm High-Speed Connectors, 1000, 2000, 3000 Series, Electrical Performance Data for Differential Applications", FCI Framatome Group, 2000, 2 pages.
- "Metral Speed & Density Extensions", FCI, Jun. 3, 1999, 1-25.
- "Mezzanine High Speed High-Density Connectors Gig-Array and Meg-Array Electrical Performance Data", FCI Corporation, 10 pages.
- "Micro Electronic Interconnects", Alphametals, 1990, 4 pages.
- "MILLIPACS Connector, Type A Specification", Dec. 14, 2004, 1 page.
- Mottonen et al., "Novel Wide-Band Coplanar Waveguide-to-Rectangular Waveguide Transition", IEEE Transactions on Microwave Theory and Techniques, 2004, 52(8), 1836-1842.
- Nadolny et al., "Optimizing Connector Selection for Gigabit Signal Speeds", <http://www.ecnmag.com-article-CA45245>, ECN, Sep. 1, 2000, 6 pages.
- "NSP Series, Backplane High-Speed Data Transmission Cable Connectors", <http://www.honda-connectors.co.jp>, Honda Connectors, 2006, 6 pages, English Translation attached.
- Ogando, "And now-An Injection-Molded Heat Exchanger", Sure, plastics are thermal insulators, but additive packages allow them to conduct heat instead, Global Design News, Nov. 1, 2000, 4 pages.
- "Open Pin Field Array Seaf Series", www.samtec.com, SAMTEC, 2005, 1 page.
- "Overview for High Density Backplane Connector (Z-Pack Tin-Man)", Tyco Electronics, 2008, 1 page.
- "Overview for High Density Backplane Connectors (Impact) Offered by Tyco Electronics", www.tycoelectronics.com/catalog, Tyco Electronics, 2007, 1-2.
- "Overview: Backplane Products", http://www.molex.com/cgi-bin/bv-molex-super_family-super_family.jsp?BV_SessionID=@, Molex, Feb. 8, 2006, 4 pages.
- "PCB-Mounted Receptacle Assemblies, 2.00 mm (0.079 In) Centerlines, Right-Angle Solder-to-Board Signal Receptacle", Metral, Berg Electronics, 2 pages.
- Power TwinBlade I/O Cable Connector RA-North-South, No. GS-20_072, Aug. 6, 2007, 11 pages.
- "Product Datasheets, 10 Bgit/s XENPAK 850 nm Transponder (TRP10GVP2045)", MergeOptics GmbH, 2005, 13 pages.
- "Product Datasheets, Welcome to XENPAK.org.", <http://www.xenpak.org>, 2001, 1 page.
- Research Disclosure, Kenneth Mason Publications Ltd., England, Aug. 1990, No. 316, 1 page.
- Research Disclosure, Kenneth Mason Publications Ltd., England, Oct. 1992, No. 342, 1 page.
- Sherman, "Plastics that Conduct Heat", Plastics Technology Online, Jun. 2001, <http://www.plasticstechnology.com>, 4 pages.
- Siemens, "SpeedPac: A New Concept for the Next Generation of Transmission Speed," Backplane Interconnection, Issue 1/96.
- Soliman. et al., "Multimodel Characterization of Planar Microwave Structures", IEEE Transactions on Microwave Theory and Techniques, 2004, 52(1), 175-182.
- Son et al., "Picosecond Pulse Propagation on Coplanar Striplines Fabricated on Lossy Semiconductor Substrates: Modeling and Experiments", IEEE Transactions on Microwave Theory and Techniques, 1993, 41(9), 1574-1580.
- Straus, "Shielded In-Line Electrical Multiconnector", IBM Technical Disclosure Bulletin, Aug. 3, 1967, 10(3), 3 pages.
- Suh et al., "Coplanar Strip line Resonators Modeling and Applications to Filters", IEEE Transactions on Microwave Theory and Techniques, 2002, 50(5), 1289-1296.
- "Two-Piece, High-Speed Connectors", www.tycoelectronics.com/catalog, Tyco Electronics, 2007, 1-3.
- "Tyco Unveils Z-Pack TinMan Orthogonal Connector System", <http://www.epn-online.com/page/new59327/tyco-unveils-z-pack-orthogonal-conn>, Oct. 13, 2009, 4 pages.
- Tzuang et al., "Leaky Mode Perspective on Printed Antenna", Proc. Natl. Sci. Coun. ROC(A), 1999, 23(4), 544-549.
- "Ventura High Performance, Highest Density Available", <http://www.amphenol-tcs.com/products/connectors/backplane/ventura/index.html>, Amphenol TCS (ATCS), Jun. 19, 2008, 1-2.
- "VHDM Connector", <http://www.teradyne.com/prods/tcs/products/connectors/backplane/vhdm/index.html>, Amphenol TCS (ATCS), Jan. 31, 2006, 2 pages.
- "VHDM Daughterboard Connectors Feature Press-Fit Terminations and a Non-Stubbing Separable Interface", Teradyne, Inc. Connections Sys Div, Oct. 8, 1997, 46 pages.
- "VHDM High-Speed Differential (VHDM HSD)", <http://www.teradyne.com/prods/bps/vhdm/hsd.html>, Teradyne, Jan. 24, 2000, 6 pages.
- "VHDM L-Series Connector", http://www.teradyne.com/prods/tcs/products/connectors/backplane/vhdm_1-series/index.html, Amphenol TCS(ATCS), 2006, 4 pages.
- Weller et al., "High Performance Microshield Line Components", IEEE Transactions on Microwave Theory and Techniques, 1995, 43(3), 534-543.
- Williams et al., "Accurate Transmission Line Characterization", IEEE Microwave and Guided Wave Letters, 1993, 3(8), 247-249.
- Wu et al., "Full-Wave Characterization of the Mode Conversion in a Coplanar Waveguide Right-Angled Bend", IEEE Transactions on Microwave Theory and Techniques, 1995, 43(11), 2532-2538.
- "XCede® Connector", <http://www.amphenol-tcs.com/products/connectors/backplane/xcede/index.html>, Amphenol TCS (ATCS), Jun. 19, 2008, 1-5.
- Ya et al., "Microstrip and Slotline Two-Pole Microwave Filters with Additional Transmission Zeros", Int. Crimean Conference, Microwave & Telecommunication Technology, 2004, 405-407 (English Abstract provided).
- "Z-Dok and Connector", <http://2dok.tyco.electronics.com>, Tyco Electronics, May 23, 2003, 1-15.
- "Z-Pack Slim UHD", <http://www.zpackuhd.com>, Tyco Electronics, 2007, 8 pages.
- "Z-Pack TinMan High Speed Orthogonal Connector Product Feature Selector", Tyco Electronics, 2009, 2 pages.

(56)

References Cited

OTHER PUBLICATIONS

“Z-Pack TinMan Product Portfolio Expanded to Include 6-Pair Module”, Tyco Electronics, Jun. 19, 2008, 1 page.

* cited by examiner

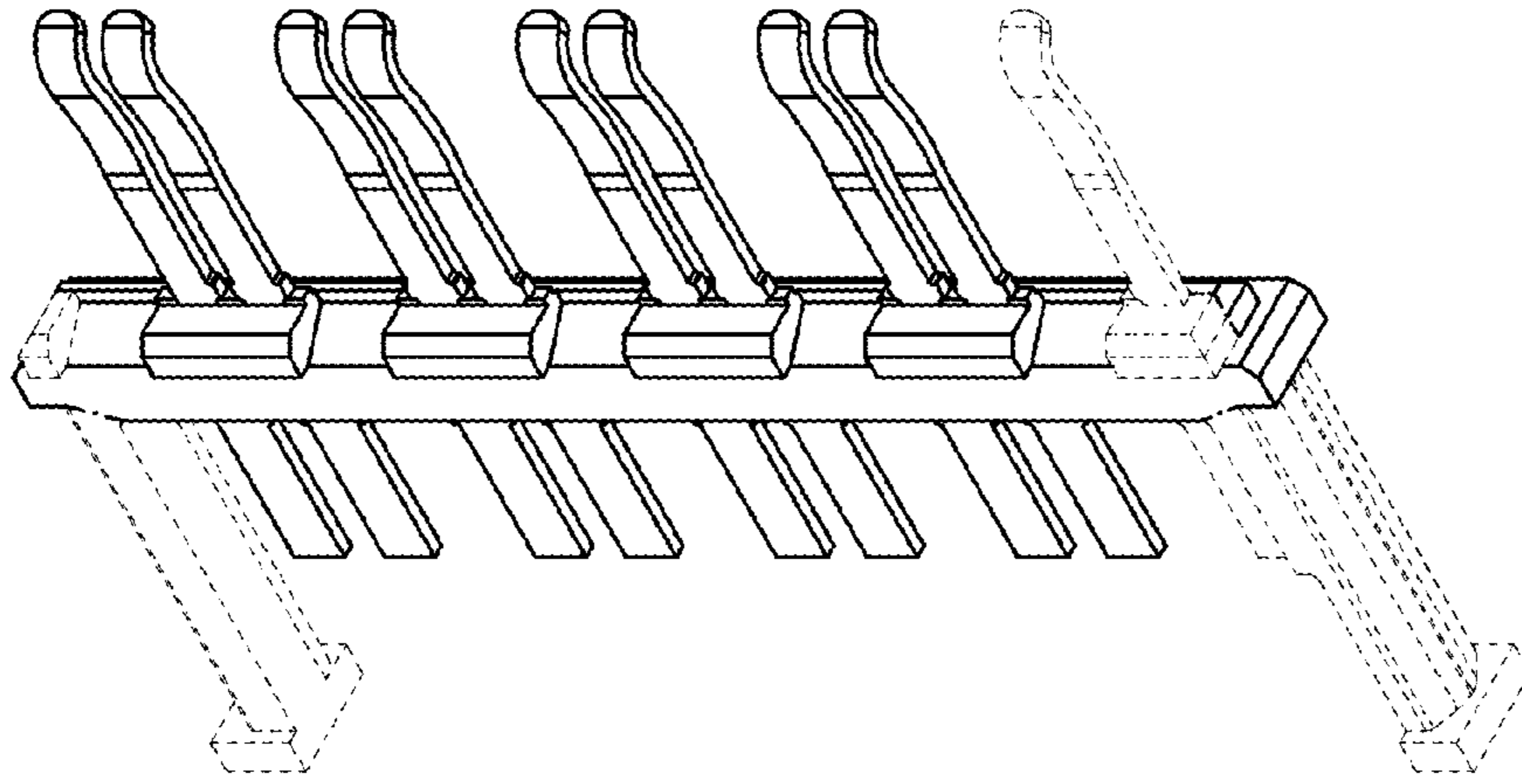

Fig.2

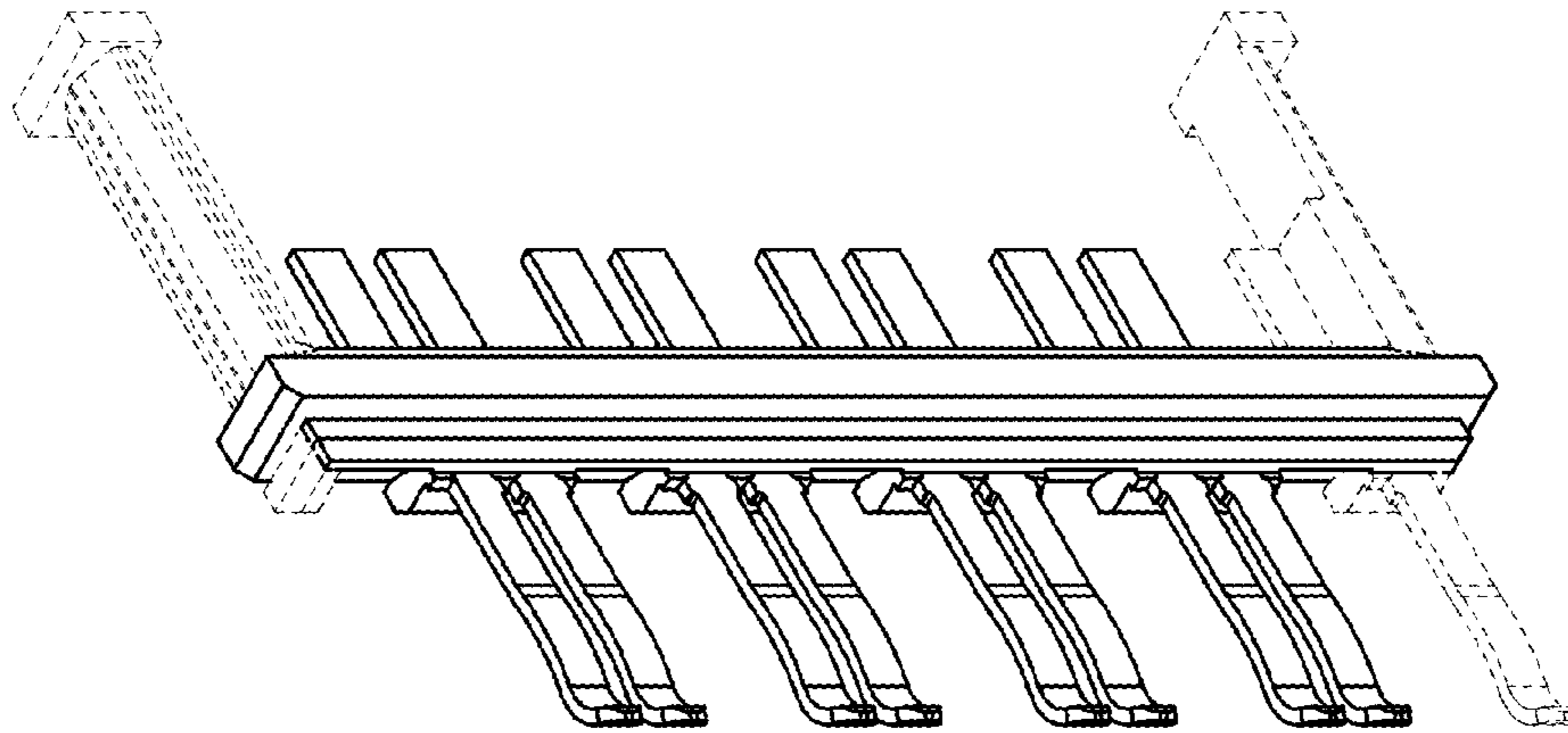

Fig.1

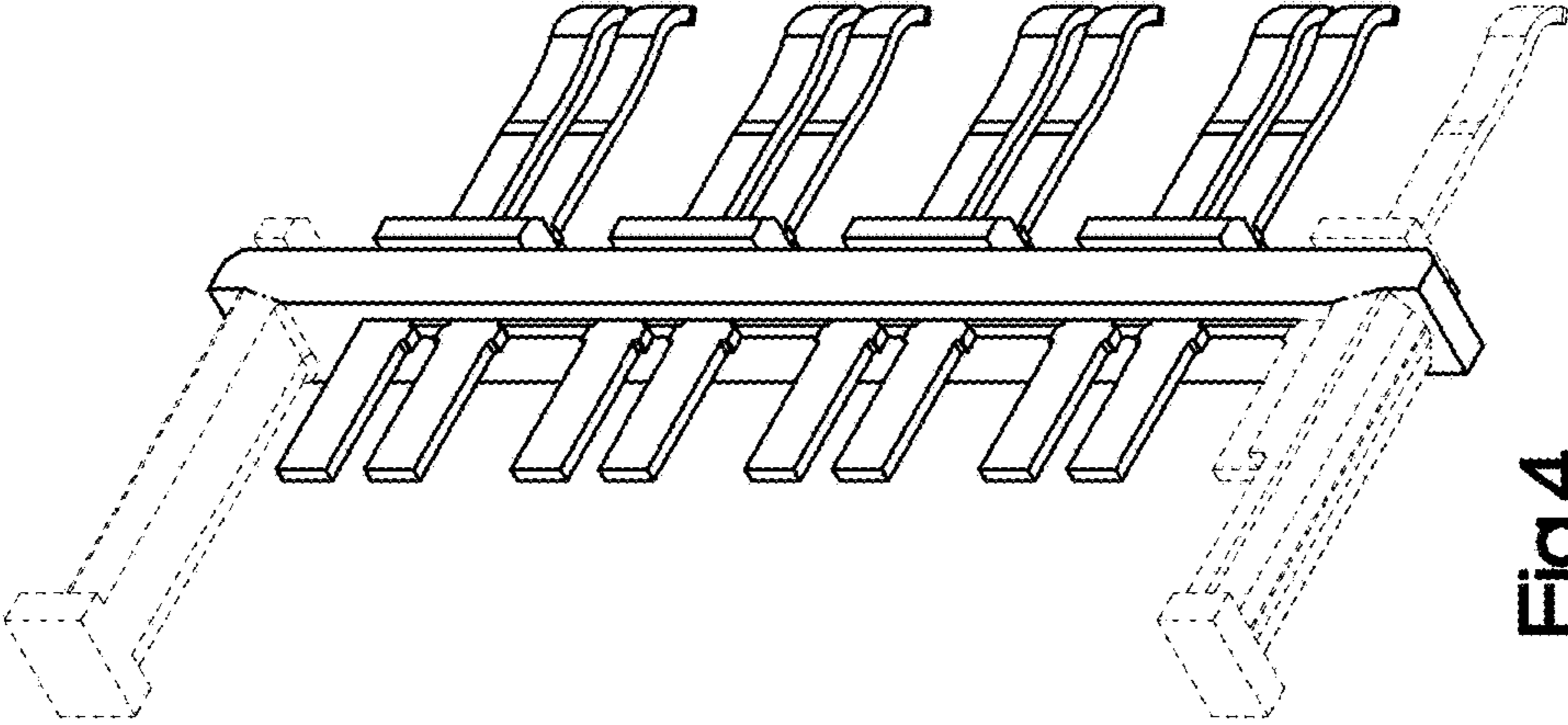

Fig.4

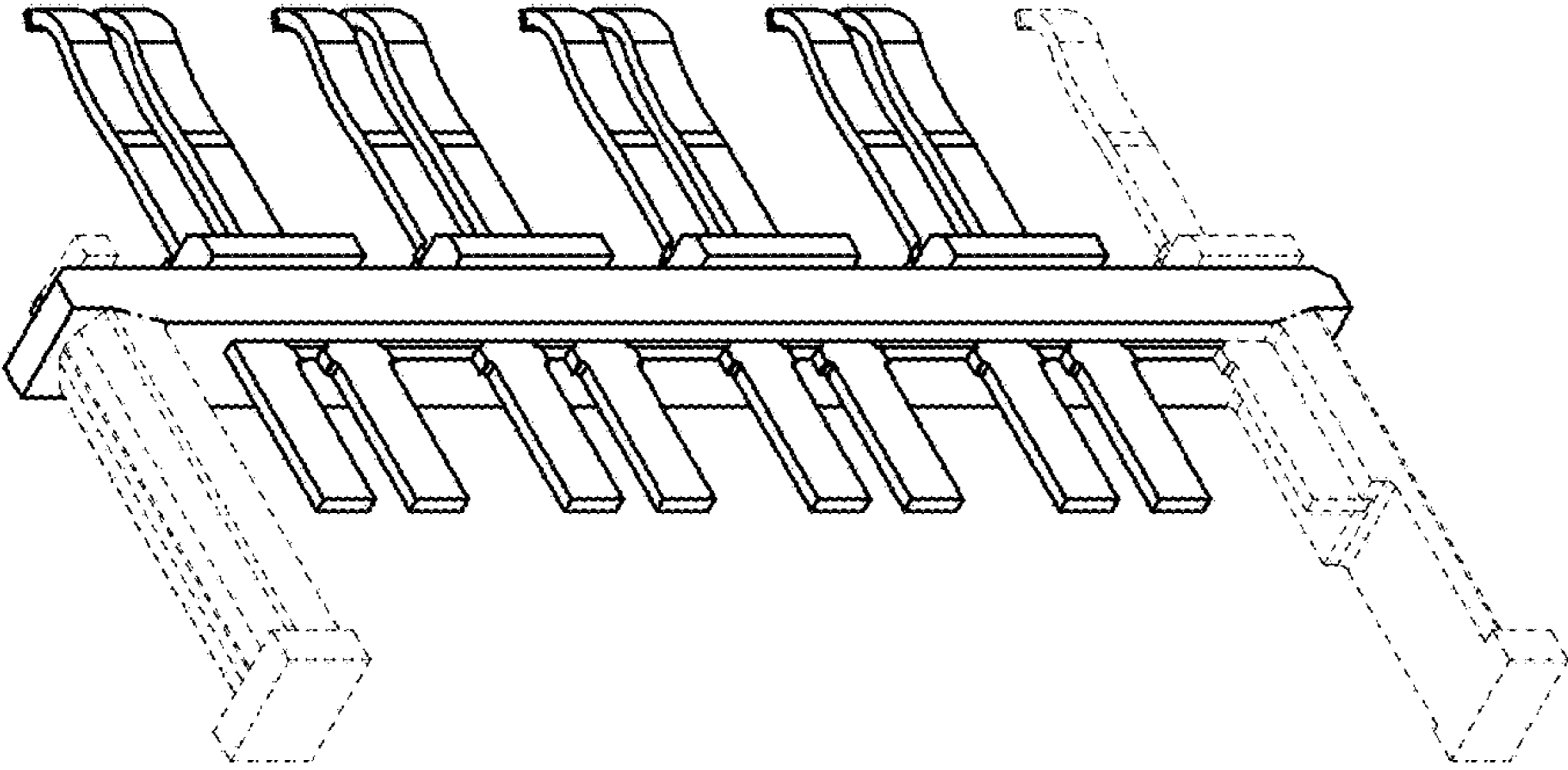

Fig.3

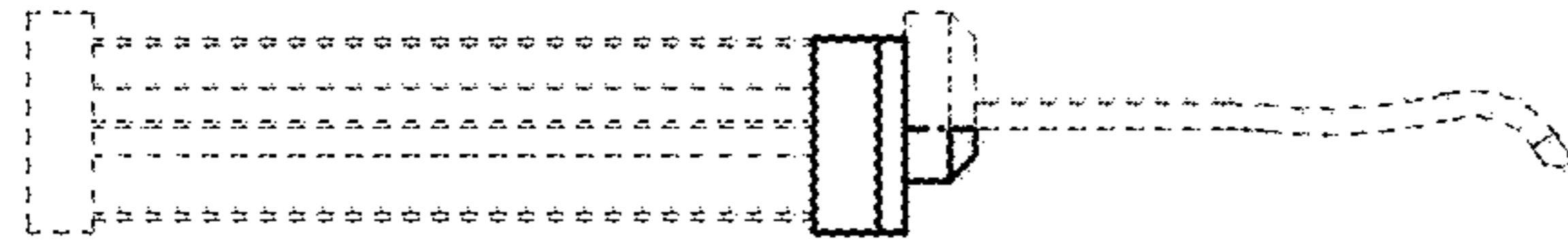

Fig.8

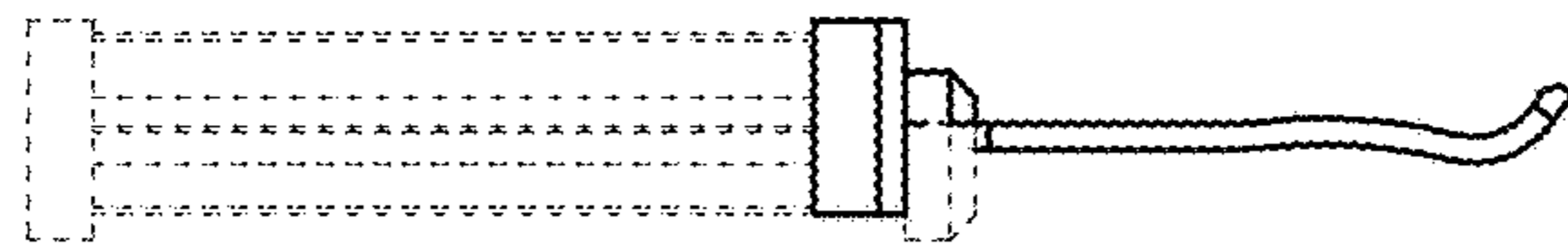

Fig.7

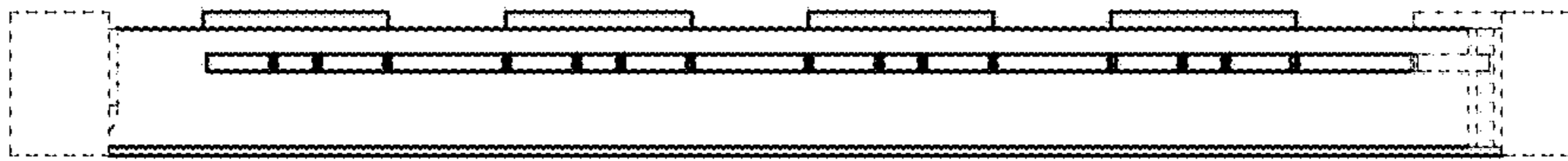

Fig.6

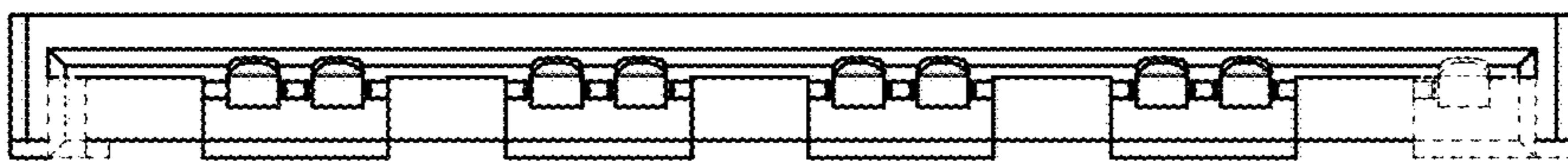

Fig.5

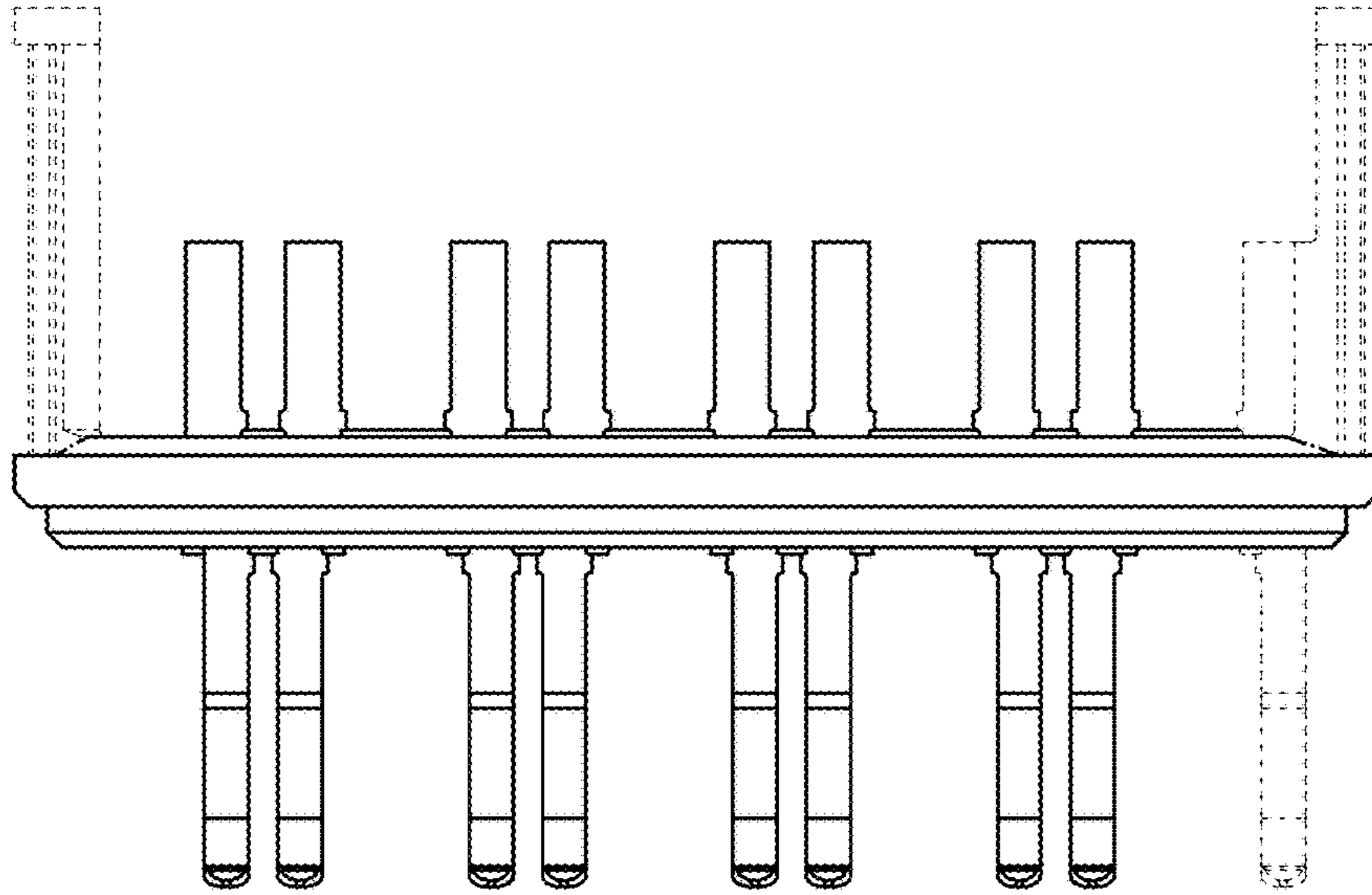

Fig.10

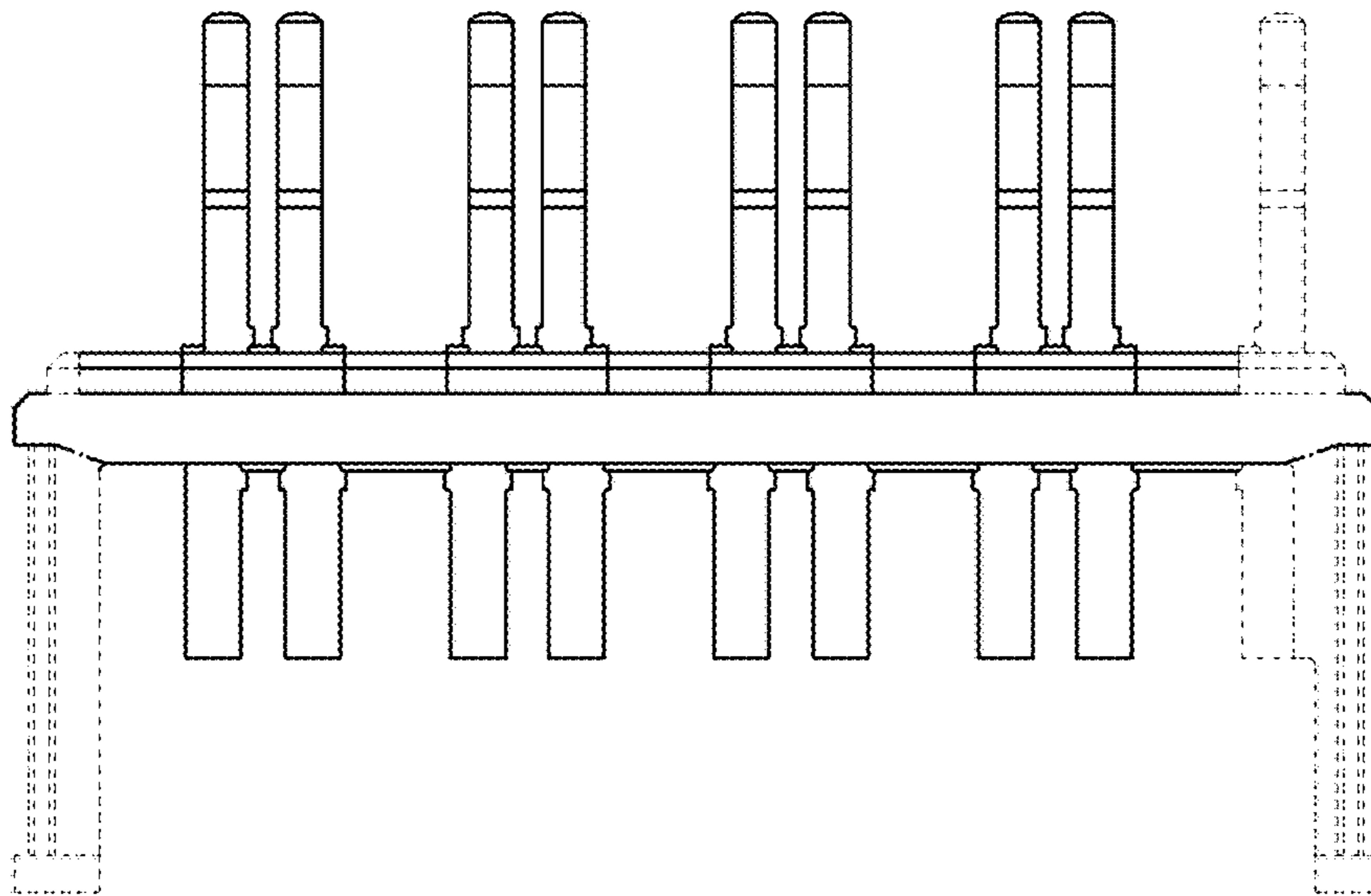

Fig.9